



ICONS

INTRODUCTION

At Icons of Denmark, we believe that modern workspaces should be as dynamic and adaptable as the people who use them. Within these pages, we invite you to explore our innovations in system design; pre-determined sets of inter-linked modules and adjustable toolkits that evolve and adapt within contemporary interior settings.

Our ambition extends beyond mere functionality. We design products that embrace change, actively encourage collaboration, and provide the infrastructure to create functional, habitable spaces tailored to changing needs. Every product here represents a flexible and reconfigurable interior solution thoughtfully designed to support spaces as they respond to the shifting physical and behavioural habits inherent in modern work.

And finally, as our world undergoes transformative changes, we've seen an increasing demand for environmentally conscious, long-term solutions with built-in futureproofing. "The Dynamics of Work" explores and celebrates this design thinking, developing systems deeply rooted in flexibility and sustainability.

Thanks for joining us on this journey.

BLOX SYSTEM	04
BANK MODULAR SOFA	10
EKKO MODULAR SOFA	14
4T SYSTEM	20
SCALA TABLE SYSTEM	26

BLOX SYSTEM

DESIGNED BY PETER BARRETH



Peter Barreth is a Danish furniture and product designer based in Aarhus. A bold simplicity underpins his work, as he notes, "All additional decorations are cut away, leaving only a refined, elegant form." This philosophy is evident in his impressive designs, characterised by simplicity, functionality, and clean lines – the hallmarks of Danish Design.

A third-generation upholsterer, Barreth honed his skills in traditional construction and upholstery techniques. He now blends these time-tested methods with innovative materials to reimagine mid-century

design for the modern world, particularly addressing contemporary workspaces' demands for growth and flexibility.

"Thoughtfully designed modular products make it incredibly easy for architects and designers to incorporate them into their projects. By offering a standard set of components, we eliminate the need for bespoke solutions, providing straightforward and flexible options that can easily be reconfigured and rearranged to match the changing needs of both the space and its people."



BLOX — REBUILD WITH THE CLICK OF A BLOCK



BANQUETTE SEATING



TIERED SEATING



MOBILE



PLANTER



BANQUETTE SEATING

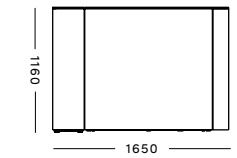
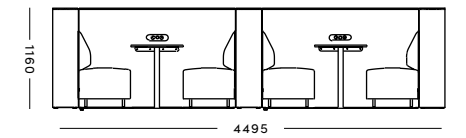
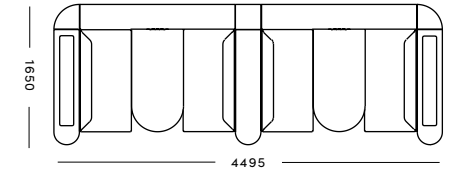

KEY FACTS

Product Modular interior system

Categories Banquette 150 / Banquette 300 / Tiered Seating / Mobile / Planter

Designed by Peter Barreth

BLOX is an innovative, scalable kit of parts designed to seamlessly adapt to the evolving needs of your workspace — at the click of a block. This interior system is crafted for creativity, offering unparalleled modularity across a range of spaces and requirements.

The external panels and tops are available in a variety of materials, giving you endless possibilities to update and develop the look of your BLOX system over time.

CURATED PANEL FINISHES

POLYGOOD	FENIX	LINOLEUM	LAMINATE	OAK VENEER	FABRIC
Pattern No5	Viola Orissa	Conifer	Diamond Black	Black	Group 1
Greycious	Grigio Aragona	Olive	Graphite	Smoked	Group 2
Timeless Duo Blue	Rosso Jaipur	Mauve	Mouse	Clear	Group 3
Marbellous	Rosso Namib	Burgundy	Thistle	White Pigmented	Group 4

MATERIAL COMPOSITION

These percentages illustrate the weight of each material.

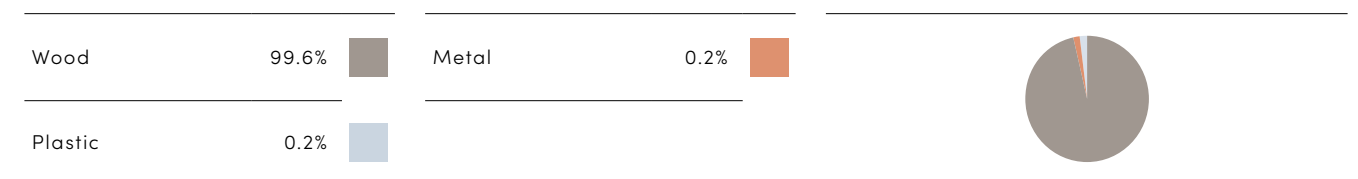

*components grouped based on function

**based on 1200x900x300mm module with oak veneer panels

CONFIGURATION OPTIONS

Engineered with robust, internal frames that connect effortlessly, BLOX removes the need for traditional joinery, allowing you to repurpose and reconfigure your environment with ease.

BANQUETTE SEATING 150

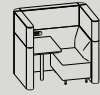

BAN 150 01



BAN 150 02

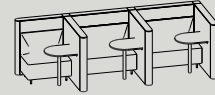

BAN 150 03



BAN 150 04



BAN 150 05

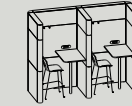

BAN 150 06

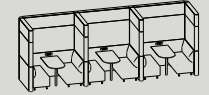

BAN 150 07

BANQUETTE SEATING 300



BAN 300 01

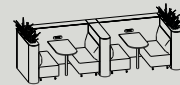

BAN 300 02



BAN 300 03



BAN 300 04



BAN 300 05

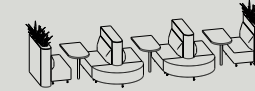

BAN 300 06

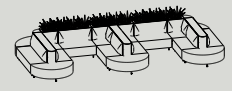

BAN 300 07

TIERED SEATING

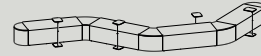

TIR 01

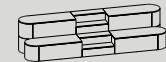

TIR 02



TIR 03

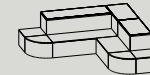

TIR 04

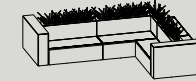

TIR 05



TIR 06

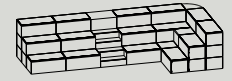

TIR 07

MOBILE

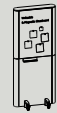

MOB 01



MOB 02

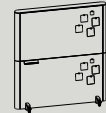

MOB 03



MOB 04

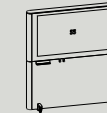

MOB 05

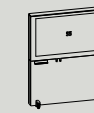

MOB 06



MOB 07

PLANTER



PLA 01



PLA 02



PLA 03



PLA 04



PLA 05



PLA 06



PLA 07



LINEAR | CONFIGURATION LINOS



ORGANIC



CORNER

KEY FACTS

Product Modular banquette sofa

Categories Banquette Sofa / Linear / Corner / Curve / Circular

Designed by Peter Barreth

Bank sofa is a modular seating system designed to perfectly complement dining, banquette, and booth settings, providing ergonomic seating at standard chair height.

KVADRAT UPHOLSTERY

0 Remix, Clara

1 Re-wool, Melange Nap, Hero, Hero Heather, Sport

2 Fiord, Hallingdal, Steelcut Trio, Steelcut, Canvas, Colline, Encircle

3 Divina Melange, Twill Weave, Vidar, Arda

4 Coda

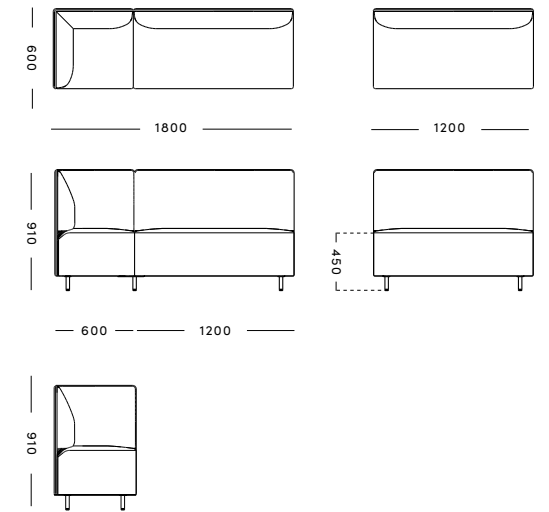

LEG OPTIONS

CURATED UPHOLSTERY

LEG OPTIONS	GROUP 1	GROUP 2	GROUP 3	GROUP 4
Powder Coated Black Steel Leg	Re-wool 0687	Fiord 0981	Divina Melange 0457	Coda 0962
Oak Veneer Black Lacquer Plinth	Melange Nap 0751	Hallingdal 0960	Vidar 0323	Coda 0222
Oak Veneer Smoked Lacquer Plinth	Sport 0213	Steelcut Trio 0906	Arda 0201	Coda 0103
Oak Veneer Clear Lacquer Plinth				
Oak Veneer White Pigmented Lacquer Plinth				

MATERIAL COMPOSITION

These percentages illustrate the weight of each material.

Wood	80.8%		Metal	2%	
Foam	11.6%		Glue	1.5%	
Fabric	3.6%		Plastic	0.5%	

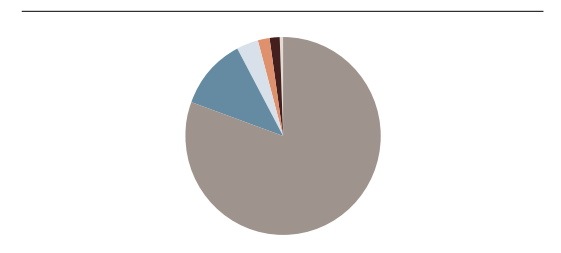

*components grouped based on function

** based on 2 seater sofa with fabric upholstery and metal legs

CONFIGURATION OPTIONS

Bank's simple geometry introduces casual elegance to social settings without the need for joinery, while plush high-density foam ensures posture-support and shape retention - making it the ideal seating system for anywhere people gather.

SOFA & CHAIR

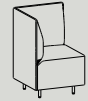

SOFA 01

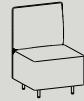

SOFA 02



SOFA 03



SOFA 04

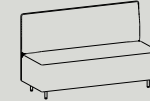

SOFA 05

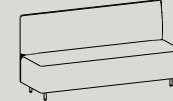

SOFA 06

LINEAR

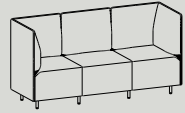

LIN 01

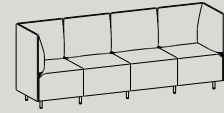

LIN 02

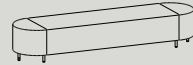

LIN 03

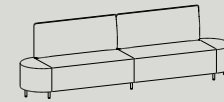

LIN 04

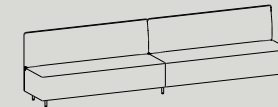

LIN 05

CORNER



COR 01



COR 02

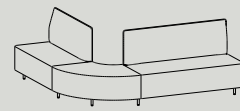

COR 03

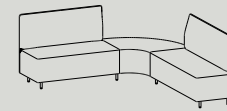

COR 04

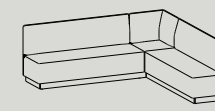

COR 05

CURVE

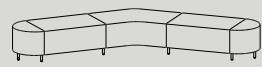

CUR 01



CUR 02

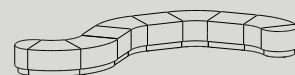

CUR 03

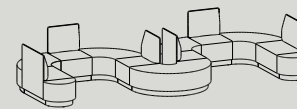

CUR 04

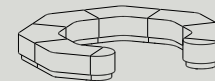

CUR 05

ORGANIC



ORG 01

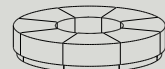

ORG 02

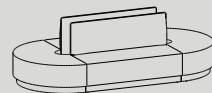

ORG 03

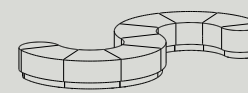

ORG 04

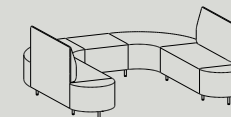

ORG 05

EKKO MODULAR SOFA
DESIGNED BY BORIS BERLIN



Boris Berlin's design philosophy is simple: "Good design is always international." Emigrating to Copenhagen in the 1980s, Boris has continually reinterpreted the principles of Danish Modernism, using it to infuse global perspectives into his work. This philosophy is fundamental to today's international workplace — ensuring spaces transcend cultural boundaries, combining the best of all worlds to create something uniquely compelling.

Berlin continues to nurture his design practice by exhibiting globally and guest lecturing at multiple universities. He has

been the recipient of the Red Dot, German Design, Good Design awards, and numerous others. Additionally, his products are included in the collections of MOMA, the Indianapolis Museum of Art, and the Design Museum Denmark.

"When I started to develop my ideas for the Ekko, I wanted the product to be organic in line and shape, but within the interior of the product to still allow it to fit within angular or confined architectural spaces. The result was a rectangular, tight shape on the outside and a plush, organically shaped interior that supported the user."

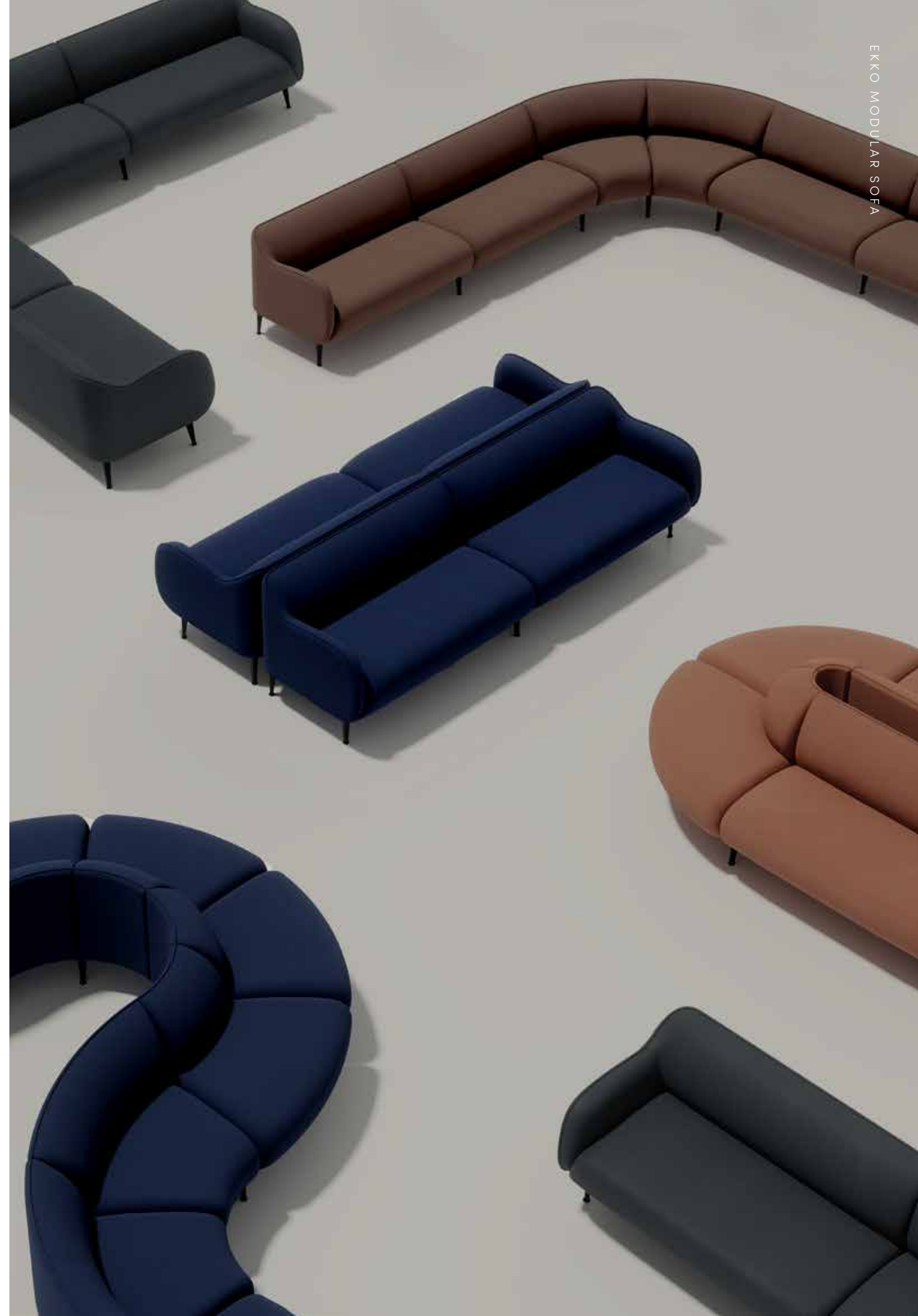

EKKO MODULAR SOFA



KEY FACTS

Product Modular sofa

Categories Arm chair & Sofa / Linear / Corner / Curve / Circular

Designed by Boris Berlin

Balancing flexibility, style, and comfort is a challenge for modular sofas. Each component connects easily, forming reconfigurable seating arrangements for relaxation, conversation, or reception. Ekko's clean-lined silhouette complements modern interior architecture, while continuous piping highlights precise upholstery.

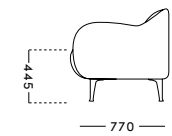
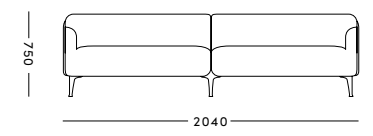
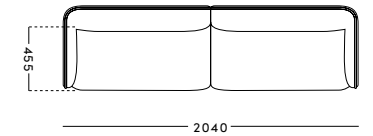

KVADRAT UPHOLSTERY

Group 0 Remix, Clara

Group 1 Re-wool, Melange Nap, Hero, Hero Heather, Sport

Group 2 Fiord, Hallingdal, Steelcut Trio, Steelcut, Colline, Encircle

Group 3 Divina Melange, Twill Weave, Vidar, Arda

Group 4 Coda

LEG OPTIONS









-  Oak White Pigment Lacquer
-  Oak Black Lacquer
-  Smoked Oak Lacquer
-  Powder Coated Black Steel

CURATED UPHOLSTERY

GROUP 1	GROUP 2	GROUP 3	GROUP 4
 Re-wool 0108	 Fiord 0422	 Divina Melange 0227	 Coda 0722
 Hero 0752	 Steelcut Trio 0453	 Twill Weave 0230	 Coda 0410
 Sport 0783	 Colline 0177	 Vidar 0723	 Coda 0632

MATERIAL COMPOSITION

These percentages illustrate the weight of each material.

Composite woods	36.1%		Solid pine	4.5%	
Foam	35.7%		Solid Oak	1.3%	
Plywood	13.4%		Polypropylene	0.3%	
Metal	7.7%		Adhesive	0.4%	

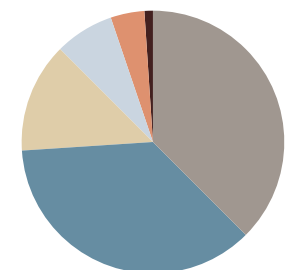

*components grouped based on function

** based on 3 seater sofa without fabric/leather

CONFIGURATION OPTIONS

Find here a selection of the vast possibilities of Ekko. From corners to atriums, receptions to breakout spaces find a configuration that defines your space.

SOFA & ARM CHAIR							
	SOFA 01	SOFA 02	SOFA 025	SOFA 03			
LINEAR							
	LIN 01	LIN 02	LIN 03	LIN 04	LIN 05	LIN 06	LIN 07
CORNER							
	COR 01	COR 02	COR 03	COR 04	COR 05	COR 06	COR 07
CURVE							
	CUR 01	CUR 02	CUR 03	CUR 04	CUR 05	CUR 06	CUR 07
CIRCULAR							
	CIR 01	CIR 02	CIR 03	CIR 04	CIR 05	CIR 06	CIR 07



4T SYSTEM
DESIGNED BY HEE WELLING



From lounge chairs to worktables and now the 4T system, Hee Welling consistently demonstrates what characterizes exceptional industrial design: the ability to integrate simplicity with functionality, addressing the scalable and evolving needs of spaces and how we use them. Educated at the Royal Danish Academy of Fine Arts, Welling draws on Denmark's rich design heritage, crafting products that focus on honest, careful use of materials.

Recognised globally, Hee Welling has received prestigious awards such as the Bo Bedre Design Award, the Good Design Award, and honours from the New Danish Art Foundation. His work is cele-

brated for its ability to transform spaces with elegance and efficiency, making a lasting impact on the design world.

"Zoning is a common challenge in open-plan workspaces, and we must find adaptable solutions. How people travel, move around, and use environments have greatly changed for office spaces, and this system helps support these changes. A few years ago, the workplace was entirely 'copy and paste' from one office to another. Right now, people want to put their personal touch on it, desiring a more 'homey' feeling of warmth; creating a place where they really like to be, rather than somewhere which looks very industrial."



BOOTH



MOBILE



PARTITION



BOOTH



ROOM

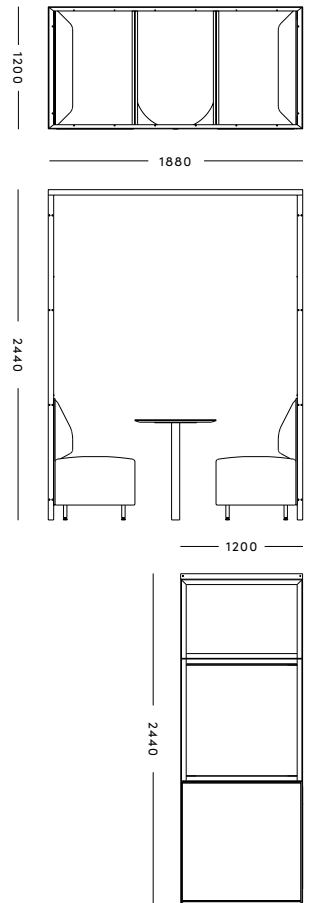

KEY FACTS

Product Modular interior system

Categories Mobile / Partition / Booth / Room

Designed by Hee Welling

Certifications Declare (International Living Future Institute)

The 4T System raises the bar on modern work. Named after its four T-irons, 4T is designed for endless reconfiguration into diverse spaces and structures using the same kit of parts. Whether wall-mounted, ceiling-mounted, freestanding, or mobile, the 4T System addresses the complex challenges of interior design, providing adaptable yet robust solutions to suit the changing demands of the workplace.

FRAME OPTIONS

-  RAL 9016 White
-  RAL 9005 Black
-  RAL 7043 Grey
-  RAL 6009 Fir Green
-  RAL 5008 Smokey Blue
-  RAL 3007 Burgundy

PANEL OPTIONS

-  Metal panel RAL range
-  Forbo bulletin boards
-  Kvadrat fabric panel
-  Lacquered light oak veneer
-  Smoked oak veneer
-  Acoustic panels
-  Whiteboard
-  Reeded Perspex® plexiglass 10 mm
-  Frosted Perspex® plexiglass 10 mm

MATERIAL COMPOSITION

These percentages illustrate the weight of each material. Items with a weight <1% of the total product weight are not included.

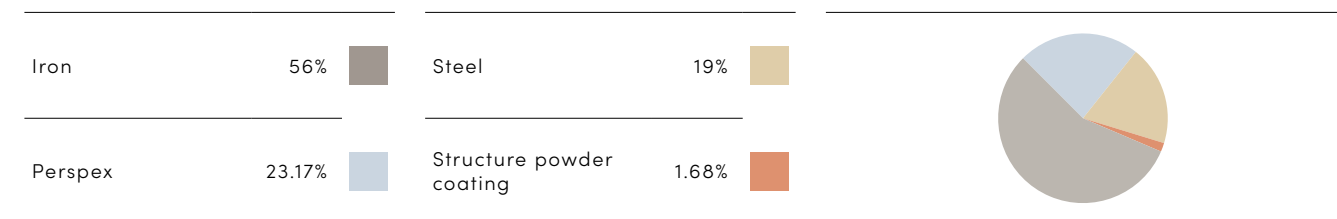

*Components grouped based on function

**Based on 1200x2400mm frame with steel and perspex panel

CONFIGURATION OPTIONS

Whether the space requires room division, more seating options or creative work boards, 4T provides a fully integrated creative solution.

MOBILE



MOB 01



MOB 02



MOB 03



MOB 04



MOB 05

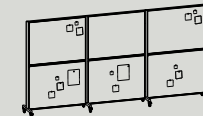

MOB 06



MOB 07

PARTITION



PAR 01



PAR 02

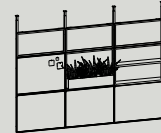

PAR 03

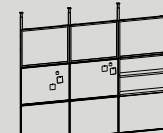

PAR 04

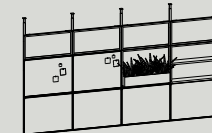

PAR 05



PAR 06

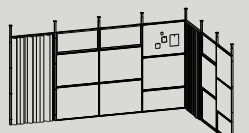

PAR 07

BOOTHS

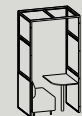

BTH 01



BTH 02



BTH 03

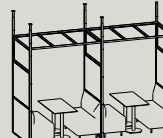

BTH 04

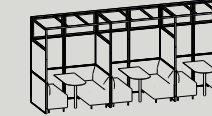

BTH 05

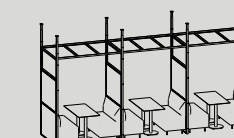

BTH 06



BTH 07

ROOMS



RMS 01

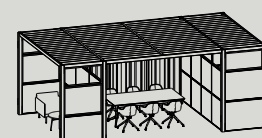

RMS 02

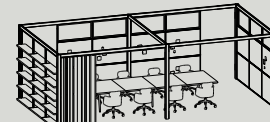

RMS 03

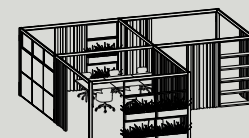

RMS 04



RMS 05



RMS 06

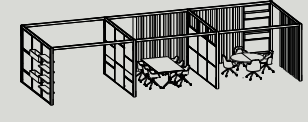

RMS 07

SCALA TABLE SYSTEM
DESIGNED BY HANS THYGE & CO



Hans Thyge, founder of the acclaimed design studio Hans Thyge & Co, continually redefines what it means to be a furniture designer. Based in Denmark, Thyge and his studio have collaborated on multiple projects with Icons of Denmark, including developing the innovative Scala Table System. This versatile solution addresses the dynamic needs of the modern office, reflecting Thyge's belief that every material holds unique properties waiting to be discovered in the design process.

A mixture of tradition and innovation distinguishes Thyge's approach to design. His studio merges traditional craftsmanship with cutting-edge technology, creating functional and aesthetically

captivating products. Thyge believes in the power of storytelling through design, where every piece reflects a narrative imbued with emotional and cultural significance.

"Many people think design is just about sketching until interesting things appear on paper. This is not true. All our expressions — whether writing on a piece of paper or playing music — are about revealing something within ourselves, and as such, all expressions become a mirror of all the cultural experiences we have gained. Being an artist, musician, or designer is about transforming heritage into imaginative images or forms, telling stories that touch our emotions."

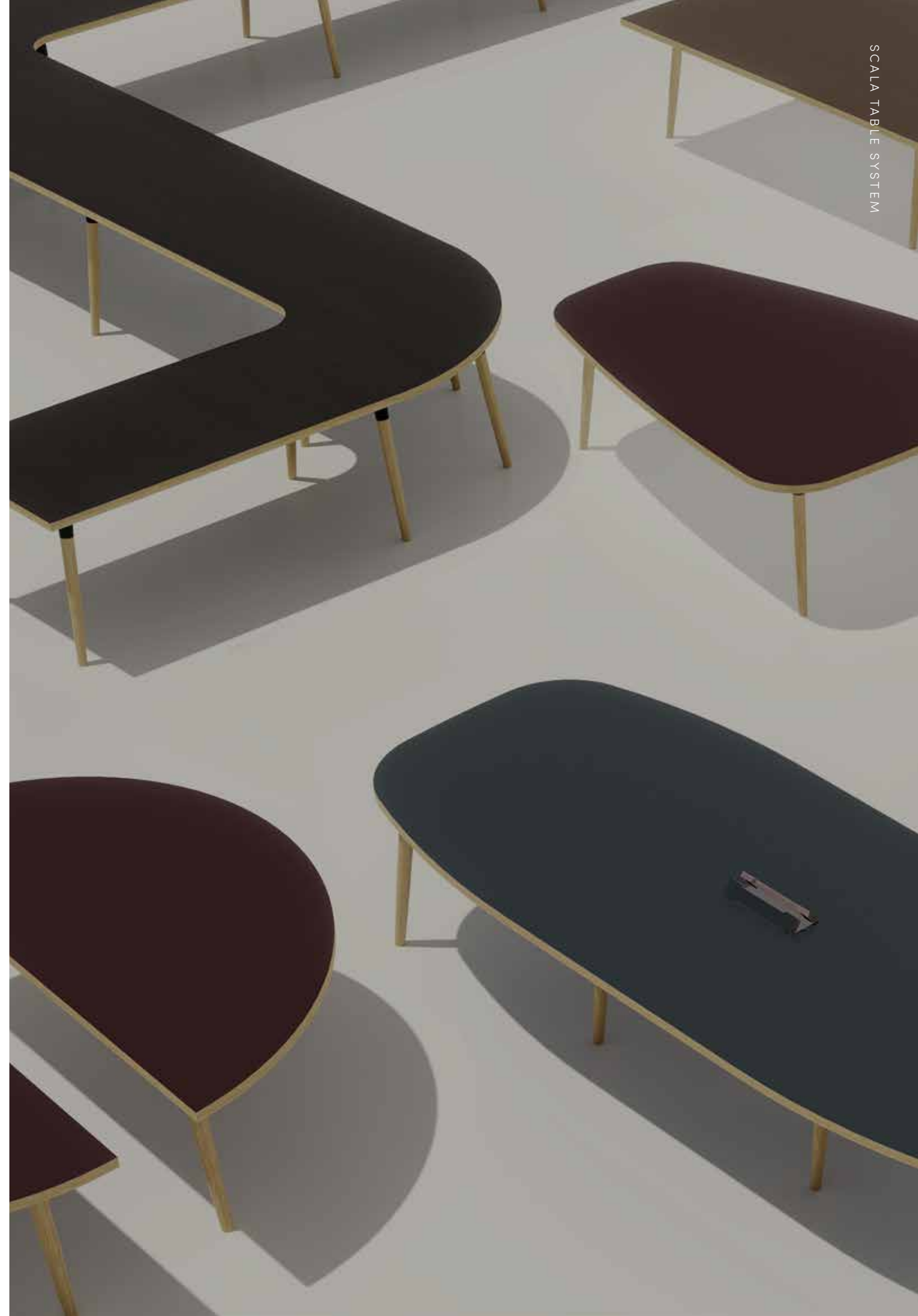



ORGANIC | CONFIGURATION ORG04



INTEGRATED CABLE COVER DETAIL



ALUMINIUM LEG FITTING

KEY FACTS

Product Modular table system
Categories Round / Dining / Organic / Hotdesk / Workstation / Barrel
Designed by Hans Thyge & Co
Certifications FSC certified timber

In today's fast-paced workplace, versatility is key. Scala delivers with a design that is easily adaptable to any setting. Rooted in Thyge's innovative table designs, Scala can be scaled and shaped to match your needs and space – long or short; round, straight, curved, or irregular. These shapes can be achieved due to the lightweight yet strong blend of the FSC certified multi-layered fibre composite table top, combined with a unique leg mechanism to replace the traditional use of strengthening beams. Every element of Scala minimises material usage and presents an eco-conscious alternative to traditional tables, while retaining structural integrity.

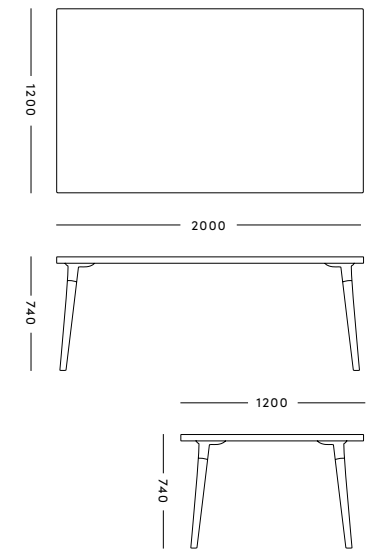

LEG OPTIONS

- Oak White Pigment Lacquer
- Smoked Oak Lacquer
- Oak Black Lacquer

CURATED TABLETOPS

FORBO LINOLEUM

- Mushroom 4176
- Pebble 4175
- Olive 4184

FORMICA LAMINATE

- Artic Blue F-5493
- Iron F-7902
- Kashmir F-0187

FENIX

- Bianco Male 0029
- Rosso Jaipur 0751
- Grigio Londra 0718

OAK VENEER

- Oak White Pigment Lacquer
- Smoked Oak Lacquer
- Oak Black Lacquer

MATERIAL COMPOSITION

These percentages illustrate the weight of each material. Items with a weight <1% of the total product weight are not included.



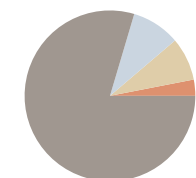









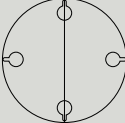
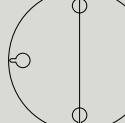
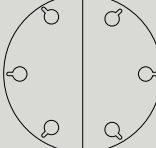
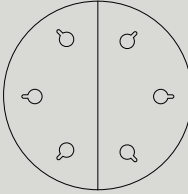

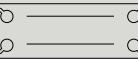



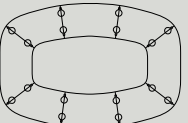
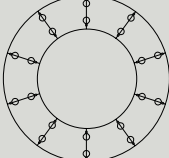
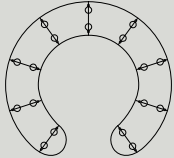
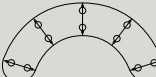
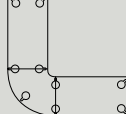



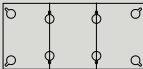
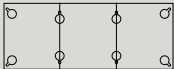

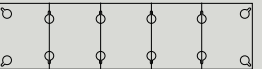
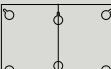
Natural fibre composite with MDF	78.5%	Aluminium	8.62%
Solid oak	9.31%	Steel	3.5%

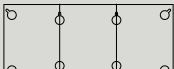

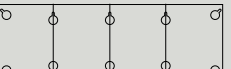
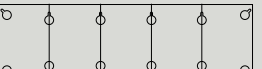
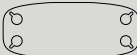
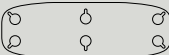
*components grouped based on function
 ** based on 1200x2000mm table

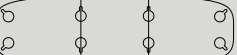
CONFIGURATION OPTIONS

The options for Scala are varied. Choose a dining, meeting, or hot-desk configuration or for more flexible spaces an irregular shape with organic forms.

<p>ROUND</p>	 <p>ROU 01</p>	 <p>ROU 02</p>	 <p>ROU 03</p>	 <p>ROU 04</p>	 <p>ROU 05</p>	 <p>ROU 06</p>	 <p>ROU 07</p>
<p>DINING</p>	 <p>DIN 01</p>	 <p>DIN 02</p>	 <p>DIN 03</p>	 <p>DIN 04</p>	 <p>DIN 05</p>	 <p>DIN 06</p>	 <p>DIN 07</p>
<p>ORGANIC</p>	 <p>ORG 01</p>	 <p>ORG 02</p>	 <p>ORG 03</p>	 <p>ORG 04</p>	 <p>ORG 05</p>	 <p>ORG 06</p>	 <p>ORG 07</p>
<p>HOT DESK</p>	 <p>HOT 01</p>	 <p>HOT 02</p>	 <p>HOT 03</p>	 <p>HOT 04</p>	 <p>HOT 05</p>	 <p>HOT 06</p>	
<p>WORKSTATION</p>	 <p>WOR 01</p>	 <p>WOR 02</p>	 <p>WOR 03</p>	 <p>WOR 04</p>	 <p>WOR 05</p>	 <p>WOR 06</p>	
<p>BARREL</p>	 <p>BAR 01</p>	 <p>BAR 02</p>	 <p>BAR 03</p>	 <p>BAR 04</p>	 <p>BAR 05</p>	 <p>BAR 06</p>	 <p>BAR 07</p>

A SUSTAINABLE SYSTEM



How can we help create a more sustainable future? It's a question we continually ask ourselves at Icons.

From our production facilities in Denmark to our offices in London, Copenhagen, Oslo and Munich, we are committed to improving our ecological impact and setting ambitious sustainability goals through a shared agenda with our designers and production partners. We focus on minimising environmental impact through careful material consideration

and creating reconfigurable, quality products designed for longevity; ensuring spaces remain adaptable to evolving requirements without compromising sustainability or style.

Our common agenda and environmental awareness guide us in pioneering new ways to enhance sustainability within our business model, ensuring that every step we take contributes to a more sustainable tomorrow.

ICONS OF DENMARK

MADE IN DENMARK

- Local production
- High environmental standards
- Forward-thinking approach to sustainable manufacturing
- Investing in Denmark's economy

THE LONGEVITY OF RECONFIGURABILITY

- Create products that last many office transformations
- 5 Year standard manufacturer's warranty
- Reconfigurable product range
- Policy of refurbishment first, rather than replacement
- Spare parts for repairs

LOOKING TO THE FUTURE

- Calculate our products carbon emissions
- Eliminate single use plastic from packaging and production
- Declare labels on all new products

KEEPING OURSELVES IN CHECK

- ISO 14001 is to create more sustainable manufacturing processes
- ISO 9001 is to demonstrate our commitment to optimising the quality procedures, ensuring the products are produced to the highest standard
- Component certification library
- Corporate Social Responsibility Statement

PARTNERING FOR SUSTAINABILITY

- Sourcing close to the production
- Choosing EU Eco Label, Green Guard Certificate and Nordic Swan Label upholstery
- ISO14001 yearly certification
- Company sustainability goals.
- Transparent supply chain

INNOVATIVE MATERIALS

- Only using certified Oeko-Tex foam
- Responsible wood sourcing
- Exploration of alternative materials
- Recycled plastic chairs
- Wool upholstery as standard
- Sourcing close to production

FURNITURE DESIGNED FOR MODERN WORK

www.iconsofdenmark.dk



ICONS

Icons of Denmark
8-10 Charterhouse Buildings, 4th & 5th Floor
Clerkenwell, EC1M 7AN
London, UK