



ICONS

We invite you to discover within these pages our Ecosystems. A pre-determined set of interlinked modules or rules, designed to depend on each other to evolve and adapt within interior architecture.

At Icons of Denmark, our ambition is to design products that embrace change, encourage collaboration, and provide the infrastructure to create functional, habitable spaces, suited for all. Every product you discover here is a flexible or reconfigurable interior solution that is designed to support your business as it responds to changing physical and behavioural habits of modern work.

We provide timely, sustainable responses to an industry seeing essential changes, where demand for conscious, long term solutions and future proofing will be the natural order.

Discover our Ecosystems and immerse yourself within our evolving world.

EKKO MODULAR SOFA SYSTEM 04

4T SYSTEM 10

SCALA TABLE SYSTEM 16

EKKO MODULAR SOFA SYSTEM
DESIGNED BY BORIS BERLIN



Designer of the Ekko sofa, Boris Berlin emigrated to Copenhagen in the 1980's. Witnessing an immense pressure on Danish designers to compete with the history of the masters of Danish Modernism, Berlin undertook this as an opportunity to bring his international design approach to his new place of residence, reinterpreting what it meant to be a designer of Danish products.

His first collaboration with Icons of Denmark resulted in the launch of our Ekko sofa – a refined, organically shaped

product that fits neatly into architectural spaces with its square profile.

Boris Berlin continues to nurture his design practice by exhibiting globally and joining as a guest lecturer at multiple universities. He is the recipient of the Red Dot, German Design, Good Design awards as well as numerous others. Additionally, his products are within the collections of renowned institutions such as the MOMA and Indianapolis Museum of Art in the USA, as well as the Design Museum Denmark.



EKKO MODULAR SOFA SYSTEM



LINEAR | CONFIGURATION LIN06

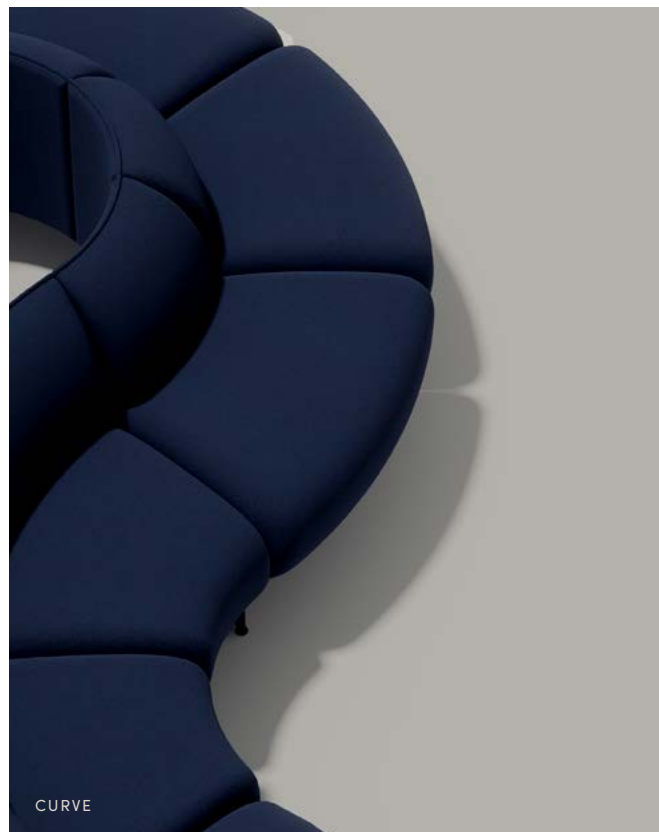

CURVE



SIDE TABLE WITH SHARED LEGS

KEY FACTS

Product Modular sofa

Categories Arm chair & Sofa / Linear / Corner / Curve / Circular

Designed by Boris Berlin

Ekko Modular Sofa System consists of multiple different modules to create numerous configurations. Module variations include features such as arms, tables and middle pieces as well as stand alone sofas in 1, 2, 2.5 and 3 seater configurations.

KVADRAT UPHOLSTERY

Group 0 Remix 143, Remix 173

Group 1 Re-wool, Sabi, Remix 3, Melange Nap

Group 2 Fiord, Hallingdal, Steelcut trio, Steelcut, Rime, Canvas, Colline, Encircle

Group 3 Divina Melange, Twill Weave, Vidar

Group 4 Coda

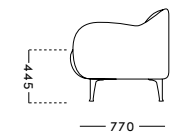
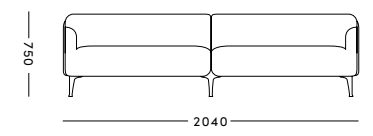
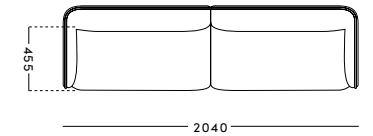

LEG OPTIONS

-  Oak White Pigment Lacquer
-  Oak Black Lacquer
-  Smoked Oak Lacquer
-  Powder Coated Black Steel

CURATED UPHOLSTERY

GROUP 1

-  Re-wool 128
-  Sabi 0741
-  Remix 3 0773



GROUP 2

-  Fiord 0422
-  Steelcut trio 0453
-  Rime 0731

GROUP 3









-  Divina Melange 227
-  Twill Weave 230
-  Vidar 723

GROUP 4

-  Coda 0011
-  Coda 0012
-  Coda 0010

MATERIAL COMPOSITION

These percentages illustrate the weight of each material.

Composite woods	36.1%		Solid pine	4.5%	
Foam	35.7%		Solid Oak	1.3%	
Plywood	13.4%		Polypropylene	0.3%	
Metal	7.7%		Adhesive	0.4%	

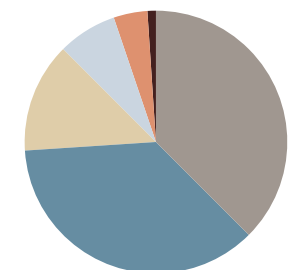

*components grouped based on function

** based on 3 seater sofa without fabric/leather

CONFIGURATION OPTIONS

Find here a selection of the vast possibilities of the Ekko Modular sofa system. From corners to atriums, receptions to breakout spaces find a configuration that defines your space.

SOFA & ARM CHAIR							
	SOFA 01	SOFA 02	SOFA 025	SOFA 03			
LINEAR							
	LIN 01	LIN 02	LIN 03	LIN 04	LIN 05	LIN 06	Ref. no.
CORNER							
	COR 01	COR 02	COR 03	COR 04	COR 05	COR 06	COR 07
CURVE							
	CUR 01	CUR 02	CUR 03	CUR 04	CUR 05	CUR 06	CUR 07
CIRCULAR							
	CIR 01	CIR 02	CIR 03	CIR 04	CIR 05	CIR 06	CIR 07

See more examples on iconsofdenmark.dk

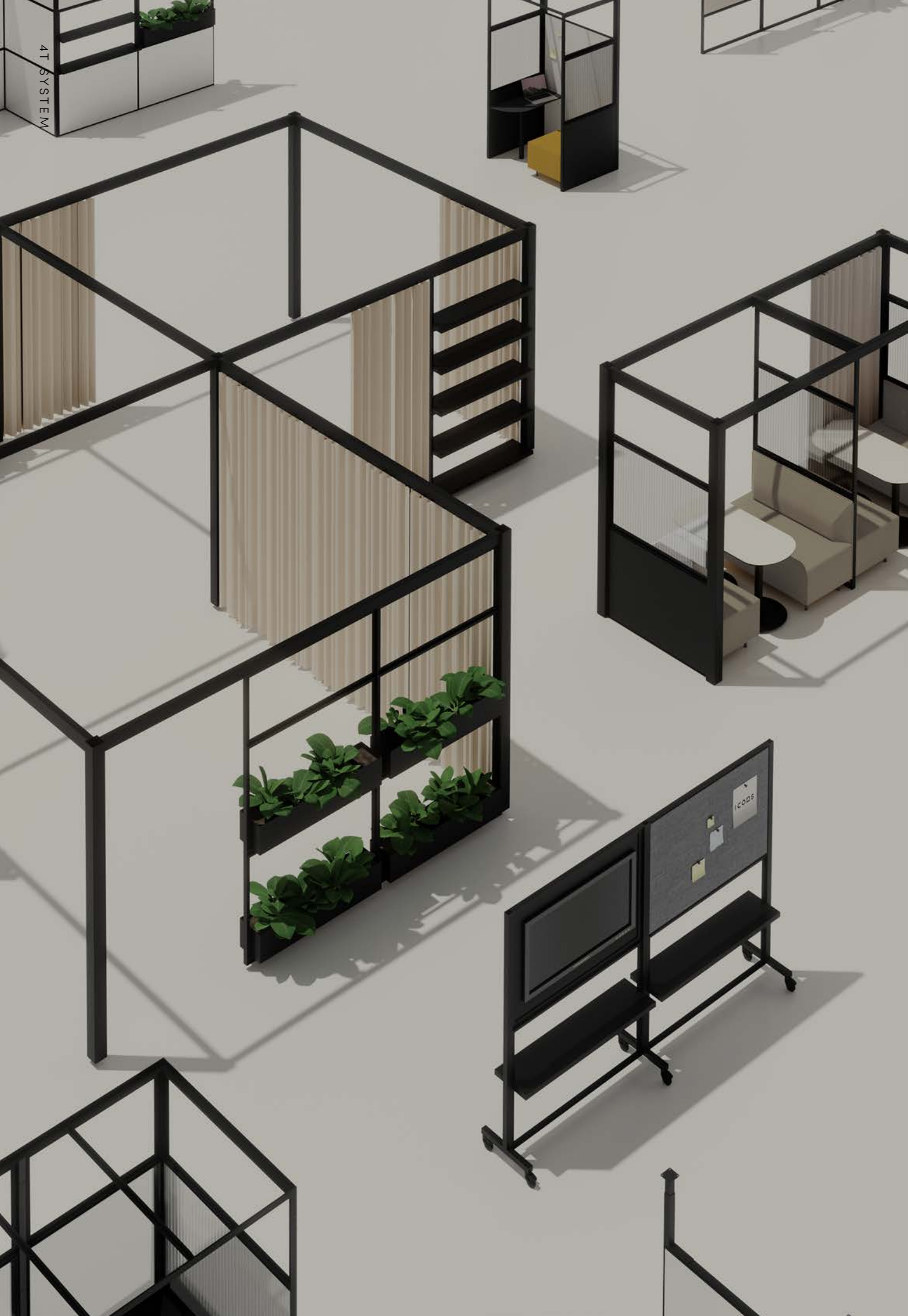

4T SYSTEM
DESIGNED BY HEE WELLING



Hee Welling's philosophy is expressed in the simple geometries and spirited contours of his products, focusing on simple useful products that pursue an honest, careful use of materials. Geometrical shapes and playful contours reoccur within his designs, while ornamentation is seen as superfluous to his work. Educated at the Royal Danish Academy of Fine Arts, Welling follows in the footsteps of Denmark's great designers. His work has been awarded several prizes, including – the Bo Bedre Design Award (Denmark), the Good Design Award (USA), the New Danish Art Foundation (Denmark). Having already designed multiple products for Icons, in 2020 the 4T System was launched, one of his most significant and complex products to date.

"The whole concept of making a system that can work as walls, as dividers, as booths, is really interesting. I think zoning is a common challenge in the market right now, that we needed to find an adaptable solution for. The way people are travelling, moving around and using environments, has changed a lot for office spaces, and this system helps support these changes. A few years ago, the workplace was quite 'copy and paste', from one office to another. Right now, people want to put their own personal touch on it, a more 'homey' feeling of warmth – creating a place where they really like to be, rather than somewhere which looks very industrial."



BOOTH

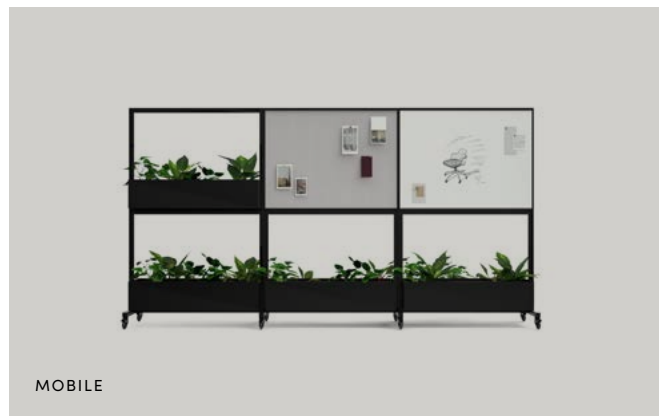

MOBILE



PARTITION

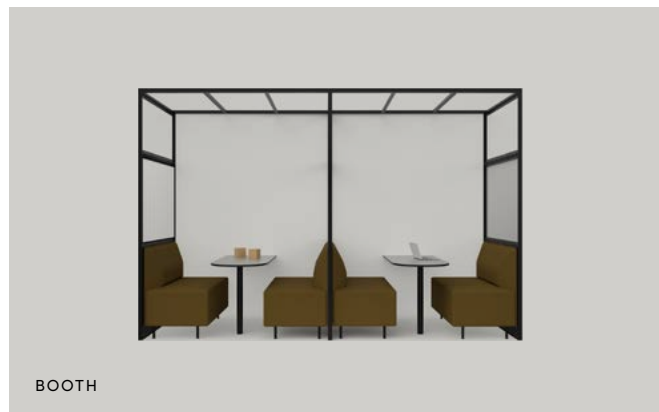

BOOTH

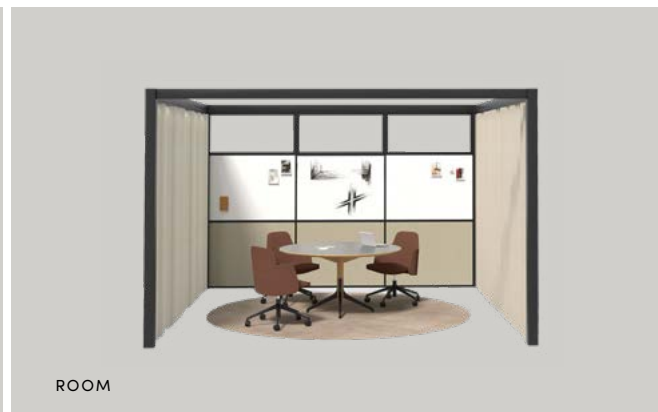

ROOM

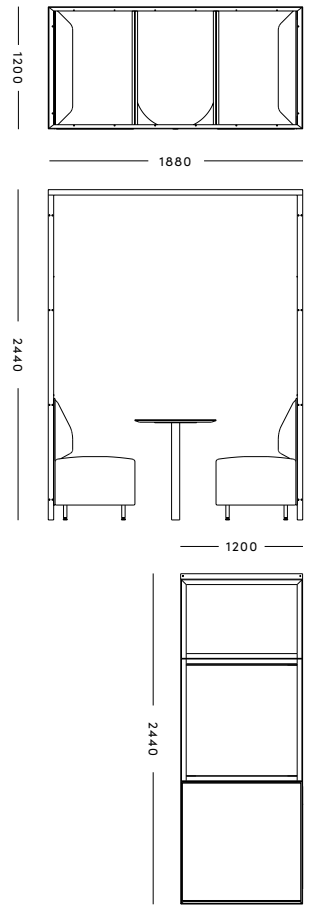

KEY FACTS

Product Modular interior system

Categories Mobile / Partition / Booth / Room

Designed by Hee Welling







Certifications Declare (International Living Future Institute)

A modular system constructed of iron, the 4T System has the capability to be endlessly reconfigured into new structures using the same kit of parts, supporting many workplace transformations. Wall or ceiling mounted to freestanding and mobile; in the rapidly changing world of workplace design, the 4T System provides an answer to complex interior design challenges both in the present and the future.

FRAME OPTIONS

-  RAL 9016 White
-  RAL 6009 Fir Green
-  RAL 9005 Black
-  RAL 5008 Smokey Blue
-  RAL 7043 Grey
-  RAL 3007 Burgundy

PANEL OPTIONS

-  Metal panel RAL range
-  Lacquered light oak veneer
-  Whiteboard
-  Forbo bulletin boards
-  Smoked oak veneer
-  Reeded Perspex® plexiglass 10 mm
-  Kvadrat fabric panel
-  Acoustic panels
-  Frosted Perspex® plexiglass 10 mm

MATERIAL COMPOSITION

These percentages illustrate the weight of each material. Items with a weight <1% of the total product weight are not included.

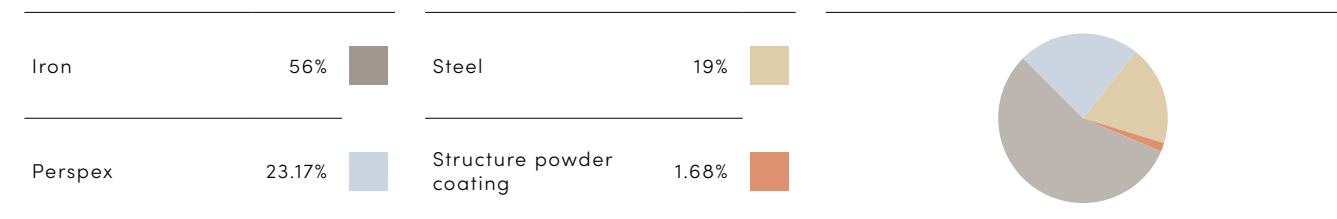

*Components grouped based on function

**Based on 1200x2400mm frame with steel and perspex panel

CONFIGURATION OPTIONS

Whether the space requires room division, more seating options or creative work boards, the 4T System provides a fully integrated creative solution.

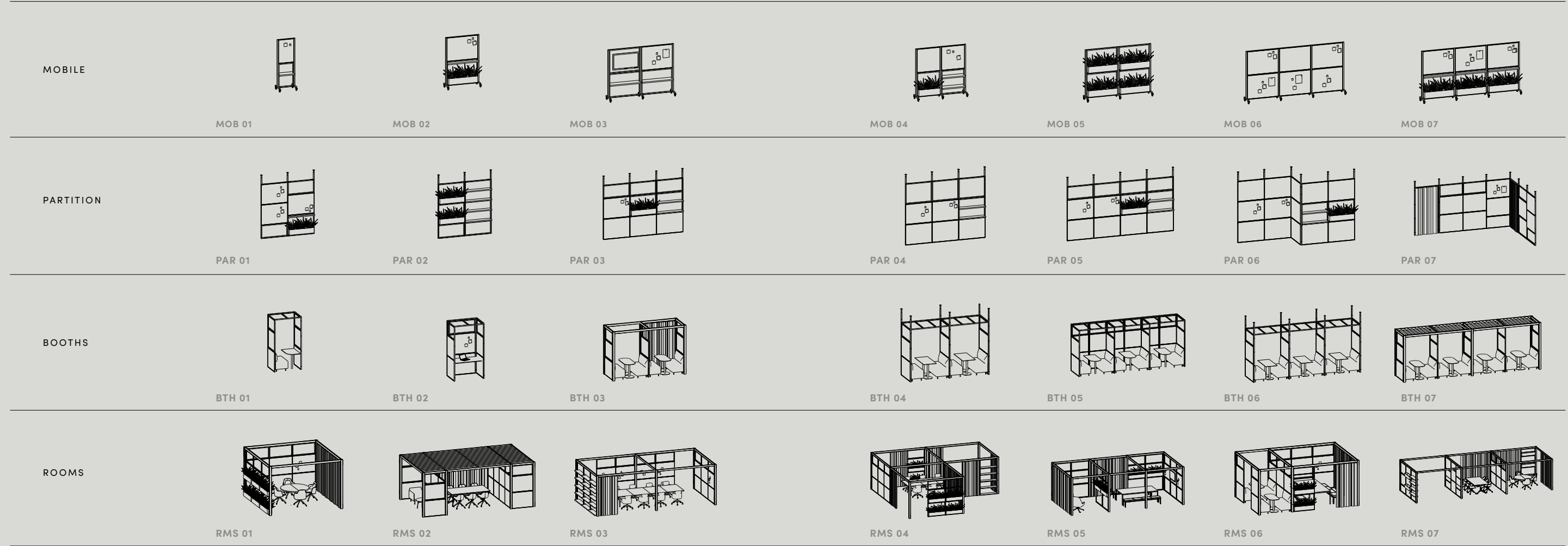

See more examples on iconsofdenmark.dk

SCALA TABLE SYSTEM
DESIGNED BY HANS THYGE & CO



Hans Thyge, founder of successful design studio Hans Thyge & Co is an established furniture designer based in Denmark. Having already collaborated on several products with Icons of Denmark, Thyge and his studio developed the Scala Table System – a versatile table system to meet the demands of the modern office.

For Thyge, all materials possess exciting properties that are to be challenged and brought out in the design process. He believes that design is a question of stimulating memories and dreams and paving the way for new design perspectives. Today, Hans Thyge leads his

design studio, a talented collective that explores design through furniture, interiors and branding concepts.

“Many people think design is just about sketching until interesting things appear on the paper, but that is not true. All our expression – whether writing on a piece of paper or playing a piece of music is about revealing something within yourself and as such all expressions become a mirror of all the cultural experiences we have gained. Being an artist, musician or designer is about being able to transform all this heritage into imaginative images or forms. To tell stories that touch our emotions.”



SCALA TABLE SYSTEM



SCALA BARREL 1200 X 2000MM



INTEGRATED CABLE COVER DETAIL



ALUMINIUM LEG FITTING WITH CABLE MANAGEMENT DETAIL

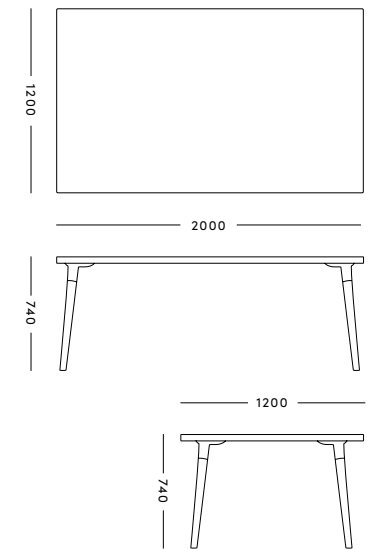

KEY FACTS

Product Modular table system

Categories Round / Dining / Organic / Hotdesk / Workstation / Barrel

Designed by Hans Thyge & Co

Certifications FSC certified timber

Created using innovative technology, Scala is a material efficient product designed for the demands of the workplace. Available in rectangular, round, barrel or organic shapes, Scala uses the strength of the FSC certified multi-layered fibre composite table top, combined with a unique leg mechanism to replace the traditional use of strengthening beams.

LEG OPTIONS

CURATED TABLETOPS

LEG OPTIONS	FORBO LINOLEUM	FORMICA LAMINATE	FENIX	OAK VENEER
Oak White Pigment Lacquer	Mushroom 4176	Artic Blue F-5493	Bianco Male 0029	Oak White Pigment Lacquer
Smoked Oak Lacquer	Pebble 4175	Iron F-7902	Rosso Jaipur 0751	Smoked Oak Lacquer
Oak Black Lacquer	Olive 4184	Kashmir F-0187	Grigio Londra 0718	Oak Black Lacquer

MATERIAL COMPOSITION



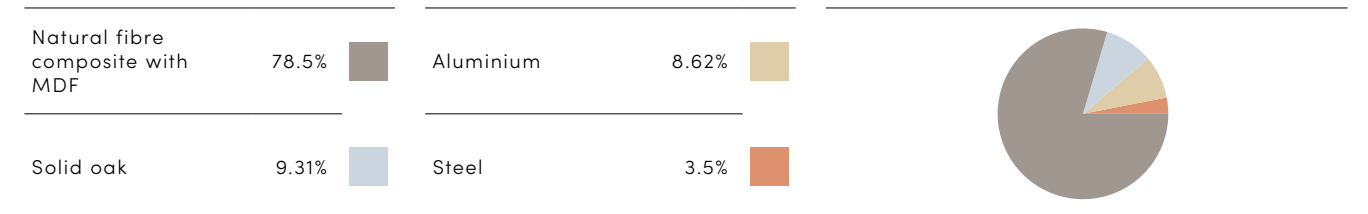







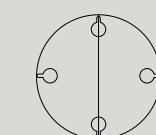
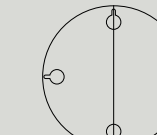
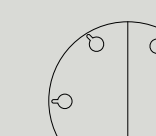
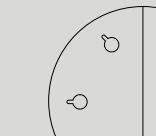
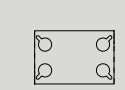
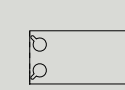
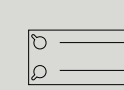

These percentages illustrate the weight of each material. Items with a weight <1% of the total product weight are not included.

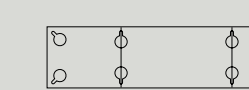
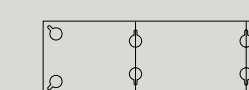
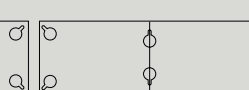
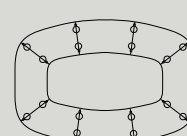
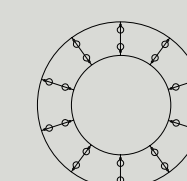
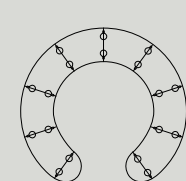

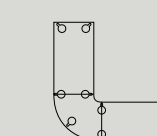
*components grouped based on function
** based on 1200x2000mm table

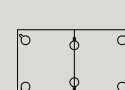
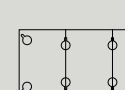
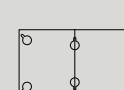
CONFIGURATION OPTIONS

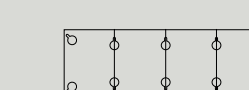
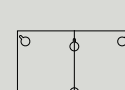
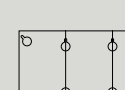
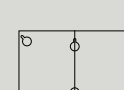
The options for Scala are varied. Choose a dining, meeting, or hot-desk configuration or for more flexible spaces an irregular shape with organic forms.

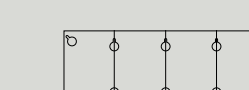
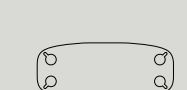
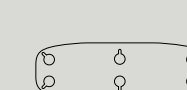
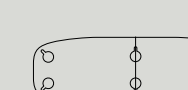
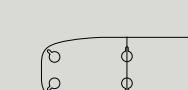
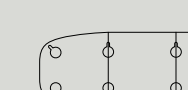
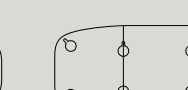
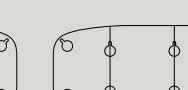
<p>ROUND</p>	 <p>ROU 01</p>	 <p>ROU 02</p>	 <p>ROU 03</p>	 <p>ROU 04</p>	 <p>ROU 05</p>	 <p>ROU 06</p>	 <p>ROU 07</p>
<p>DINING</p>	 <p>DIN 01</p>	 <p>DIN 02</p>	 <p>DIN 03</p>	 <p>DIN 04</p>	 <p>DIN 05</p>	 <p>DIN 06</p>	 <p>DIN 07</p>
<p>ORGANIC</p>	 <p>ORG 01</p>	 <p>ORG 02</p>	 <p>ORG 03</p>	 <p>ORG 04</p>	 <p>ORG 05</p>	 <p>ORG 06</p>	 <p>ORG 07</p>
<p>HOT DESK</p>	 <p>HOT 01</p>	 <p>HOT 02</p>	 <p>HOT 03</p>	 <p>HOT 04</p>	 <p>HOT 05</p>	 <p>HOT 06</p>	
<p>WORKSTATION</p>	 <p>WOR 01</p>	 <p>WOR 02</p>	 <p>WOR 03</p>	 <p>WOR 04</p>	 <p>WOR 05</p>	 <p>WOR 06</p>	
<p>BARREL</p>	 <p>BAR 01</p>	 <p>BAR 02</p>	 <p>BAR 03</p>	 <p>BAR 04</p>	 <p>BAR 05</p>	 <p>BAR 06</p>	 <p>BAR 07</p>

See more examples on iconsofdenmark.dk

A SUSTAINABLE SYSTEM



How can we strive to create a more sustainable future? It's a question that is constantly being reviewed and attempted to answer around the world.

At Icons, this is no different. We are consistently assessing our present and future goals to create a more sustainable business and looking at new ways to improve our ecological impact. From our production facilities in Denmark, to our offices

in London, Copenhagen, and Munich, we are taking significant steps to improve sustainability within our business model.

Through a shared agenda, and awareness, we are focused on bringing forward innovative solutions while minimising our impact on the environment through careful consideration of materials, and providing quality, reconfigurable and longevity focused products.

ICONS OF DENMARK

MADE IN DENMARK

- Local production
- High environmental standards
- Forward-thinking approach to sustainable manufacturing
- Investing in Denmark's economy

THE LONGEVITY OF RECONFIGURABILITY

- Create products that last many office transformations
- 5 Year standard manufacturer's warranty
- Reconfigurable product range
- Policy of refurbishment first, rather than replacement
- Spare parts for repairs

LOOKING TO THE FUTURE

- Calculate our products carbon emissions
- Eliminate single use plastic from packaging and production
- Declare labels on all new products

KEEPING OURSELVES IN CHECK

- ISO 14001 is to create more sustainable manufacturing processes
- ISO 9001 is to demonstrate our commitment to optimising the quality procedures, ensuring the products are produced to the highest standard
- Component certification library
- Corporate Social Responsibility Statement

PARTNERING FOR SUSTAINABILITY

- Sourcing close to the production
- Choosing EU Eco Label, Green Guard Certificate and Nordic Swan Label upholstery
- ISO14001 yearly certification
- Company sustainability goals.
- Transparent supply chain

INNOVATIVE MATERIALS

- Only using certified Oeko-Tex foam
- Responsible wood sourcing
- Exploration of alternative materials
- Recycled plastic chairs
- Wool upholstery as standard
- Sourcing close to production

ICONS

Icons of Denmark
Charterhouse Buildings, 4th & 5th Floor
8-10 Goswell Road, Clerkenwell
EC1M 7AN, London, UK