



Pablo®

CLAMP

CLAMP

DESCRIPTION

Designed for simplicity and engineered for sustainability, Clamp combines the beauty of wood with the brilliance of LED technology. Clamp's minimal components work together to provide infinite adjustment, while focusing warm, diffused light where needed most. Available in clamp mount, freestanding, mini and floor models in White Oak and Walnut.

DESIGNER

Dana Cannam 2011 - 2013

MATERIALS

- Wood lamp assembly
- Polyurethane bushings
- Polycarbonate lens
- Fabric cord
- Leather clamp pad (Clamp only)
- ABS cover (Clamp FS only)
- Steel base weight (Clamp FS, Mini and Floor only)
- Brass washer (Clamp Floor only)

FEATURES

- 360° arm rotation
- Advanced LED array eliminates multiple shadows
- Hi-low dim control
- Ships flat-packed

SPECIFICATIONS

- Voltage: 120-240V 60Hz
- Power Consumption: 9W (Clamp Mini: 6W)
- Color temperature: 3000K
- Luminosity: 485 Lumens (Clamp Mini: 325 Lumens)
- Luminaire efficacy: 55 Lumens/Watt
- Color Rendition Index: 85 CRI
- 50K hour lifespan
- Title 20 compliant
- Cord length: 8' (244cm)
- Global multi-plug adapter available
- 1 year warranty
- Certifications: ETL, CE, RoHS

Pablo



DIMENSIONS

CLAMP

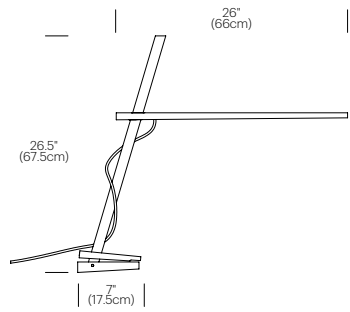

CLAMP FREESTANDING

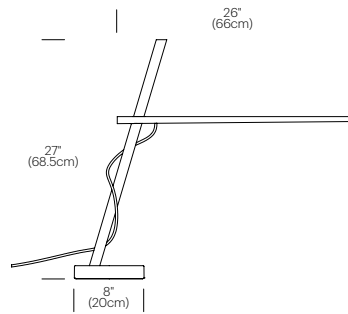

CLAMP MINI

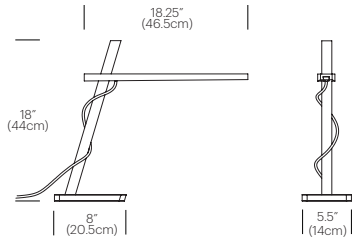

CLAMP FLOOR

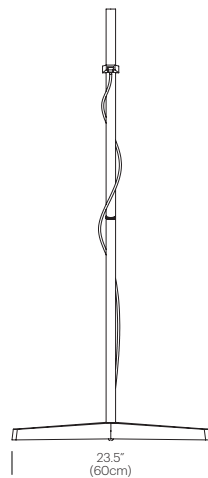
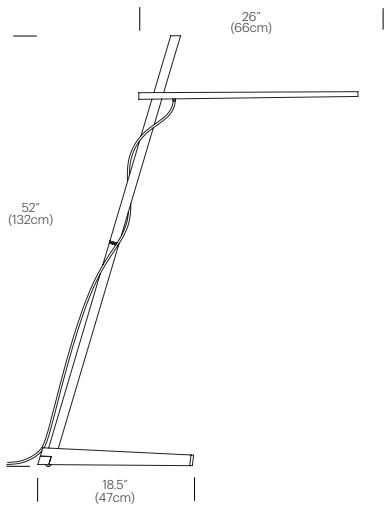

FINISH OPTIONS

CLAMP



White Oak /
Red



Walnut /
Black

FREESTANDING BASE



White

Pablo®

888 MARIN STREET SAN FRANCISCO, CA 94124
PABLODESIGNS.COM