

NICHIHA EX SERIES 3030 PANEL

VERTICAL INSTALLATION MANUAL

【Construction】 Steel Structure

【 Substrate 】 Horizontal Metal Framework

Metal framework

Overview	
Main Member	
Base	
Horizontal Junction	
Vertical Junction	
Internal Corner	
External Corner	Pre-formed Corner
Opennings	Top Bottom Sides
Soffit	Eaves Trim Sealant
Overhang	Overhang Flashing

NICHIHA EX SERIES

(3030 panel)

Substrate	Furring Strip	Panel Installation Direction	How to fix Clips (JE715)
Metal framework	Horizontal	Vertical	

Overview

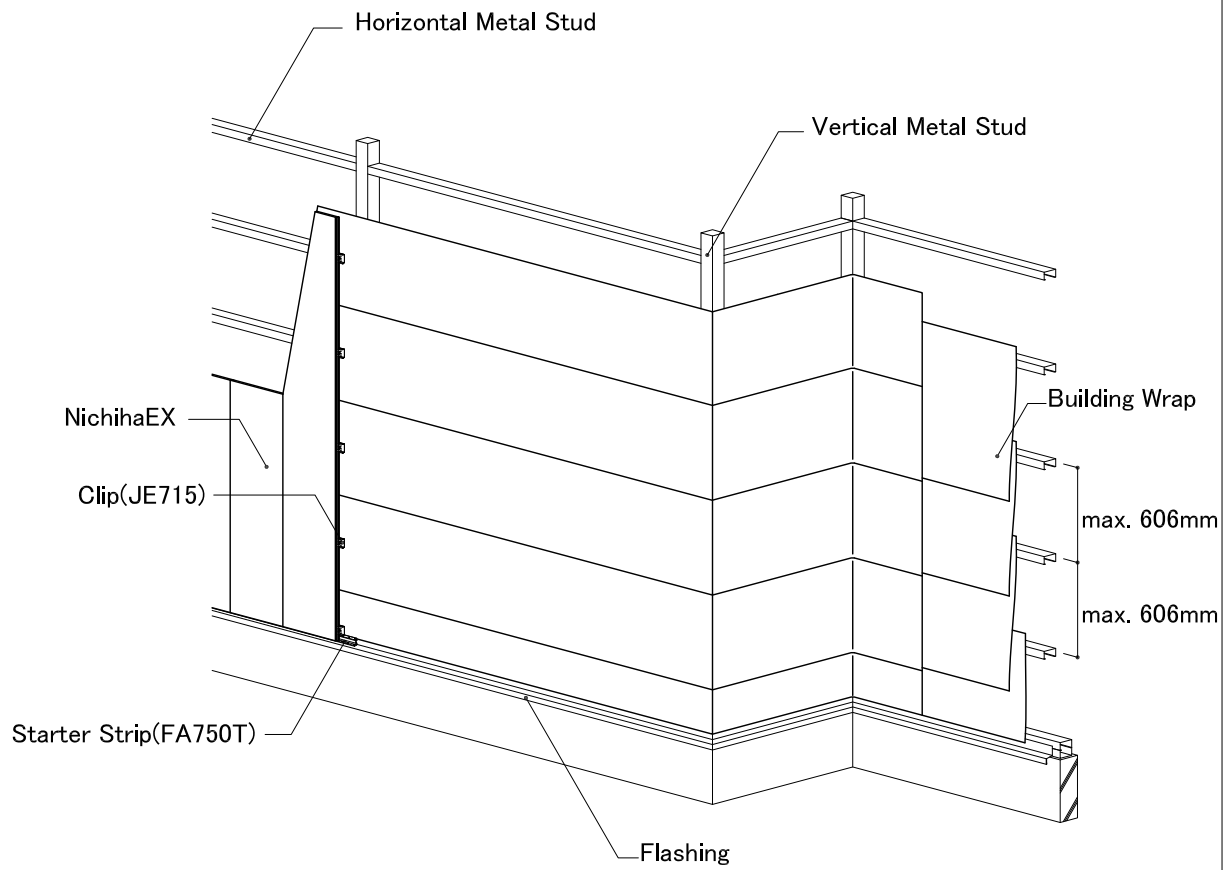

Cut Edge

Repair the cut edge of Nichiha EX. Apply sealer twice or repair coating after the sealer application with the touch-up paint.

NICHIHA EX SERIES

(3030 panel)

Substrate	Furring Strip	Panel Installation Direction	How to fix
Metal framework	Horizontal	Vertical	Clips (JE715)

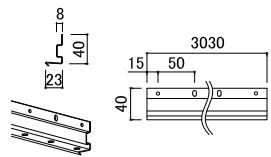
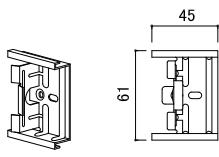
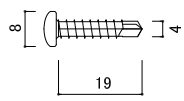
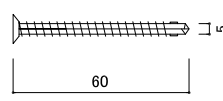
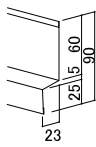
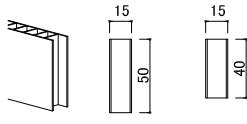
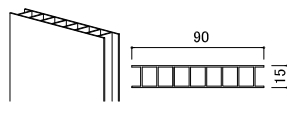
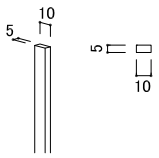
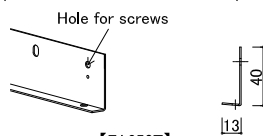
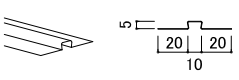
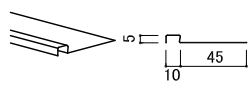
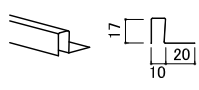
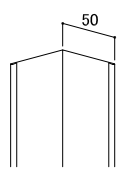
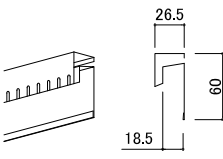
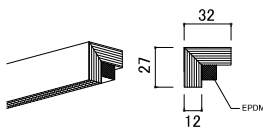
Main Accessories			
<p>■ Starter Strip</p>  <p>【FA750T】</p> <p>Material : Painted 55%Al-Zn-coated steel sheet</p> <p>Thickness : 1.0mm</p> <p>Length : 3,030mm</p> <p>Fastening : @250mm or less interval</p> <p>Note : fix with Nichiha Screws</p>	<p>■ Clip</p>  <p>【JE715】</p> <p>Material : Zn-11%Al-3%Mg-0.2%Si-coated steel sheet</p> <p>Note : fix with Nichiha Screws</p>	<p>■ Nichiha Screw (for fixing Starter Strip・Clip)</p>  <p>【JK1140】</p> <p>Material : Stainless</p> <p>Size : φ 4mm × 19mm</p>	<p>■ Nichiha Screw (for face fixing Panel)</p>  <p>【JK1250】</p> <p>Material : Stainless</p> <p>Size : φ 5mm × 60mm</p>
<p>■ Joint Flashing 23E</p>  <p>【FTA□□□□】</p> <p>Material : Painted 55%Al-Zn-coated steel sheet</p> <p>Thickness : 0.35mm</p> <p>Length : 3,030mm</p>	<p>■ Spacer 15</p>  <p>【FSP1015】</p> <p>Length : 1,200mm</p> <p>Material : Polypropylene</p> <p>(Piece Type)</p> <p>【FSP1015】</p> <p>Size : 40 × 40 × 15mm</p> <p>Material : Polypropylene</p>	<p>■ Spacer 15T</p>  <p>【FS1015T】</p> <p>Length : 2,000mm</p> <p>Material : Polypropylene</p>	<p>■ Backer Rod 05</p>  <p>【FB1005】</p> <p>Length : 1,000mm</p> <p>Material : Polyethylene foam</p>
<p>■ Starter Strip (Horizontal Junction)</p>  <p>【FA350T】</p> <p>Material : Painted 55%Al-Zn-coated steel sheet</p> <p>Thickness : 1.0mm</p> <p>Length : 3,030mm</p> <p>Fastening : @250mm or less interval</p> <p>Note : fix with Nichiha Screws</p>	<p>■ Sealant Backer Double Flange05</p>  <p>【Product number: FH1005R】</p> <p>Material : Fluoroplastic Resin Coated 55%Al-Zn-coated steel sheet</p> <p>Thickness : 0.3mm</p> <p>Length : 3,030mm</p>	<p>■ Sealant Backer Single Flange05</p>  <p>【FHK1105R】</p> <p>Material : Fluoroplastic Resin Coated 55%Al-Zn-coated steel sheet</p> <p>Thickness : 0.3mm</p> <p>Length : 2,000mm</p>	<p>■ Sealant Backer Single Flange17</p>  <p>【FHK1017R】</p> <p>Material : Fluoroplastic Resin Coated 55%Al-Zn-coated steel sheet</p> <p>Thickness : 0.3mm</p> <p>Length : 2,000mm</p>
<p>■ Corner Backing Angle50</p>  <p>【JR1900】</p> <p>Material : 55%Al-Zn-coated steel sheet</p>	<p>■ Eaves Trim 16</p>  <p>【Product number: FTM10□□】</p> <p>Material : Painted 55%Al-Zn-coated steel sheet</p> <p>Length : 3,030mm</p>	<p>■ L-Form Cavity Vent</p>  <p>【FSK1000】</p> <p>Material : Polyethylene</p> <p>Length : 1,220mm</p>	

NICHIHA EX SERIES

(3030 panel)

Substrate	Furring Strip	Panel Installation Direction	How to fix
Metal framework	Horizontal	Vertical	Clips (JE715)

Base

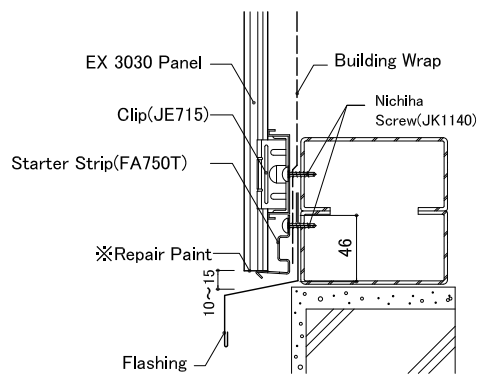
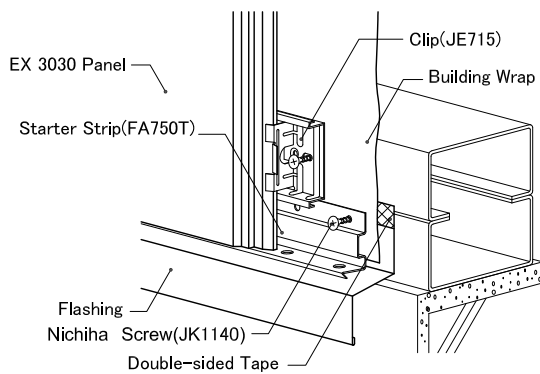

Cut Edge

Repair the cut edge of Nichiha EX. Apply sealer twice or repair coating after the sealer application with the touch-up paint.

Horizontal Junction

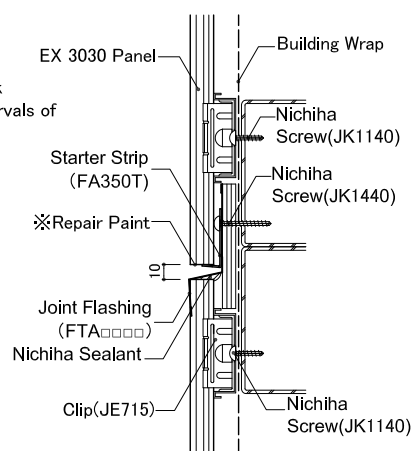
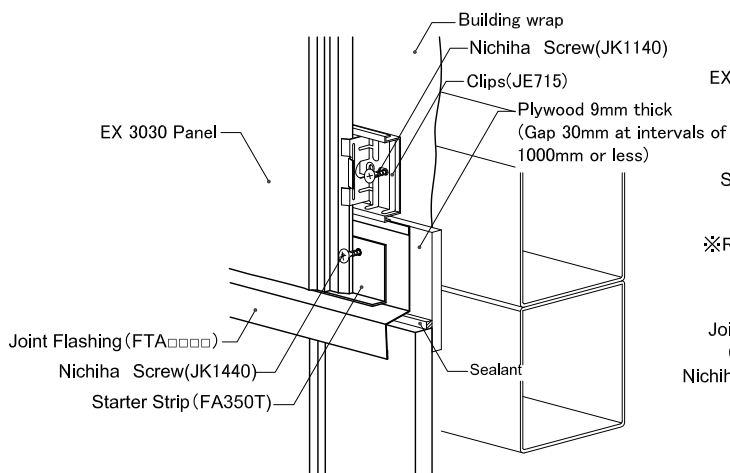

Cut Edge

Repair the cut edge of Nichiha EX. Apply sealer twice or repair coating after the sealer application with the touch-up paint.

NICHHA EX SERIES (3030 panel)	Substrate	Furring Strip	Panel Installation Direction	How to fix
	Metal framework	Horizontal	Vertical	Clips (JE715)

Vertical Joint

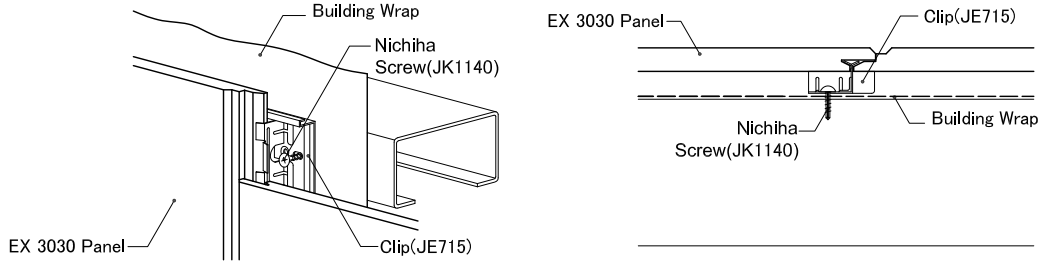

EX 3030 Panel

Clip(JE715)

EX 3030 Panel

Clip(JE715)

Nichiha Screw(JK1140)

Building Wrap

Internal Corner

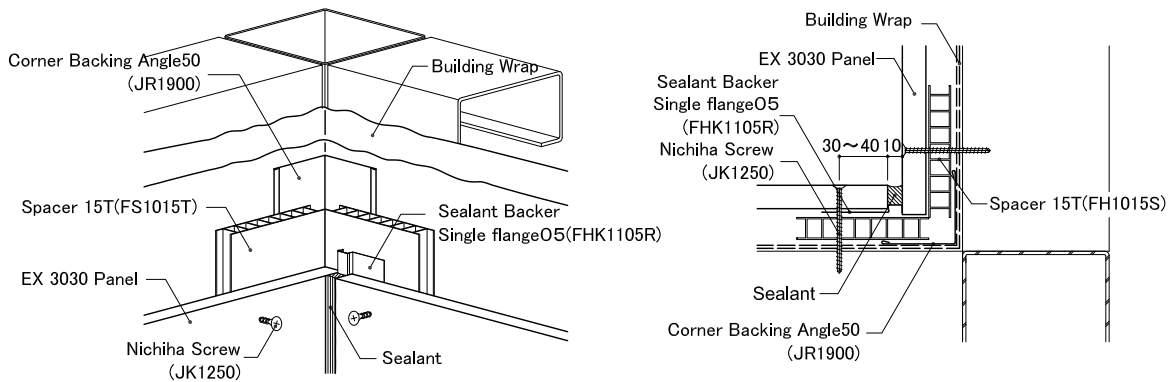

Corner Backing Angle50 (JR1900)

Building Wrap

Spacer 15T(FS1015T)

Sealant Backer Single flange05(FHK1105R)

EX 3030 Panel

Nichiha Screw (JK1250)

Sealant

Building Wrap

EX 3030 Panel

Sealant Backer Single flange05 (FHK1105R)

Nichiha Screw (JK1250)

30~40

Spacer 15T(FH1015S)

Sealant

Corner Backing Angle50 (JR1900)

Repair of the screw head

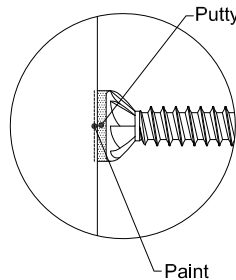

Putty

Paint

NICHIHA EX SERIES

(3030 panel)

Substrate	Furring Strip	Panel Installation Direction	How to fix
Metal framework	Horizontal	Vertical	Clips (JE715)

External Corner

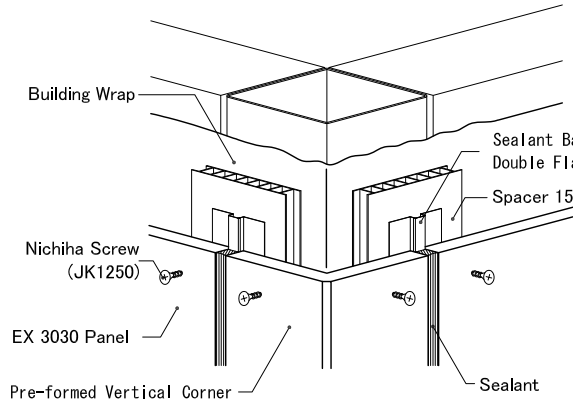

Pre-formed Corner

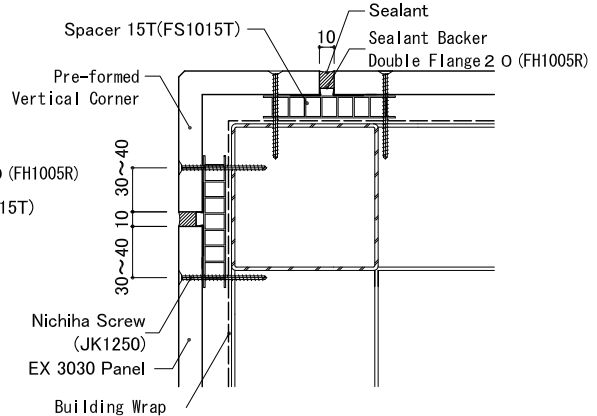

Repair of the screw head

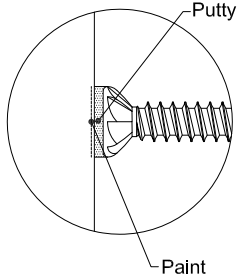

Openings

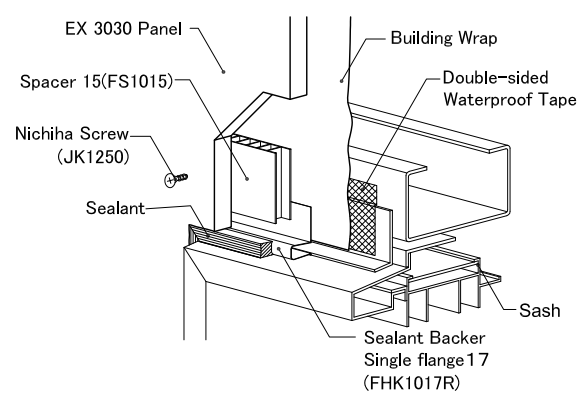

Top

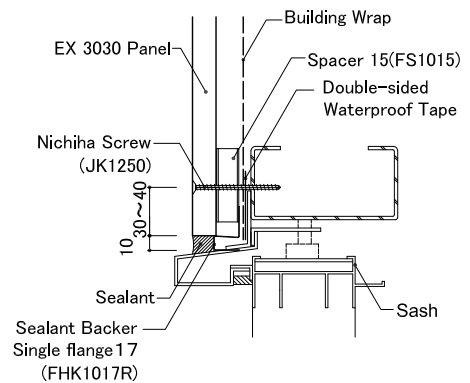

Repair of the screw head

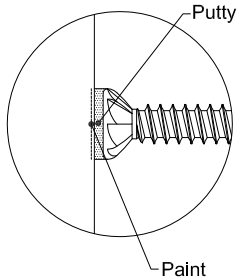

NICHIHA EX SERIES

(3030 panel)

Substrate	Furring Strip	Panel Installation Direction		How to fix
		Horizontal	Vertical	
Metal framework	Horizontal	Vertical		Clips (JE715)

Openings

Bottom

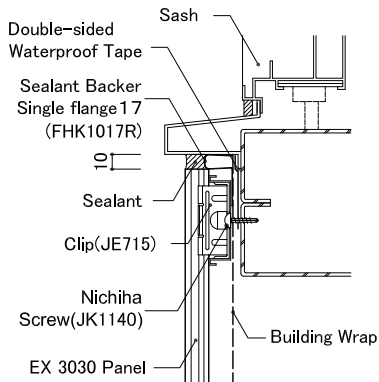
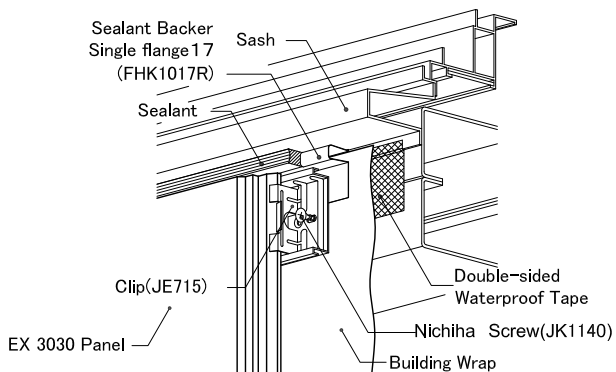

Repair of the screw head

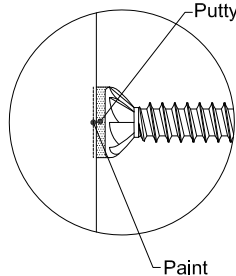

Openings

Sides

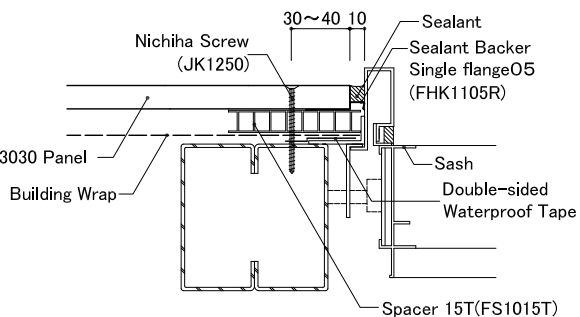
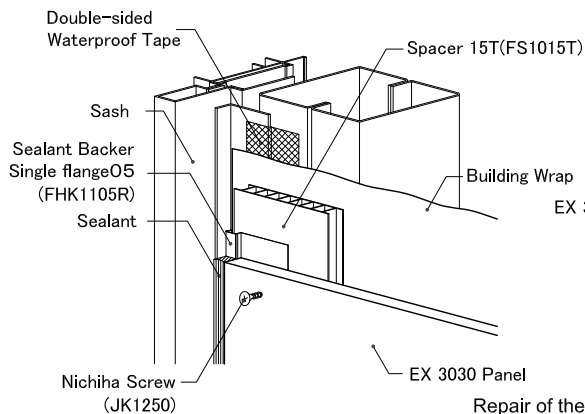

Repair of the screw head

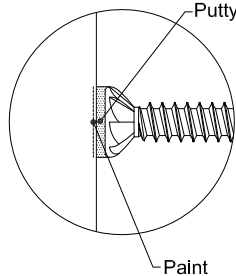

NICHIHA EX SERIES

(3030 panel)

Substrate	Furring Strip	Panel Installation Direction	How to fix
Metal framework	Horizontal	Vertical	Clips (JE715)

Soffit

Eaves Trim 16

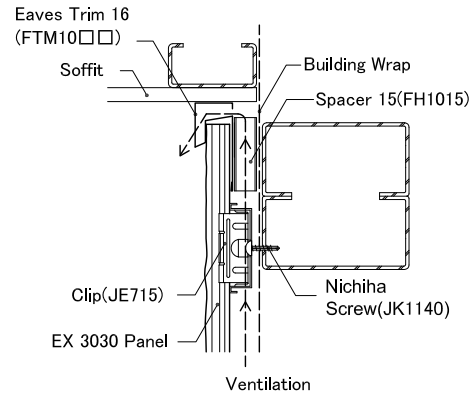
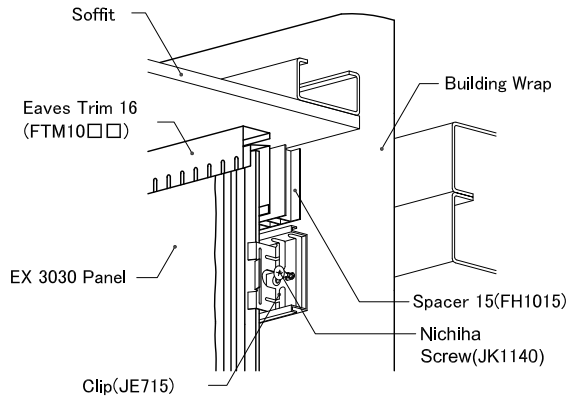

Soffit

Sealant

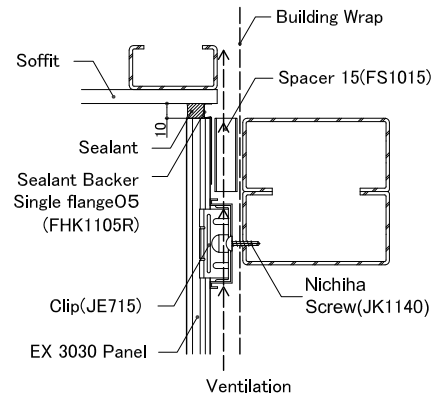
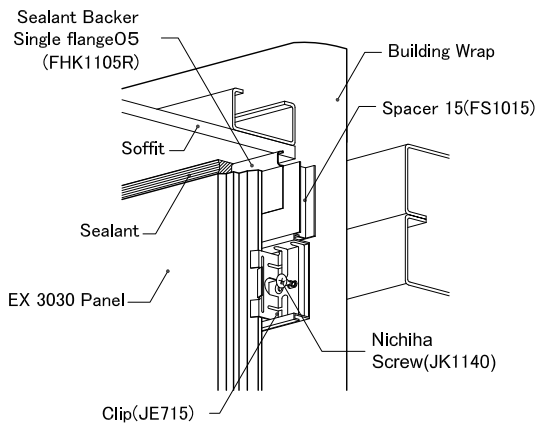

NICHIIHA EX SERIES (3030 panel)	Substrate	Furring Strip	Panel Installation Direction	How to fix
	Metal framework	Horizontal	Vertical	Clips (JE715)

Overhang

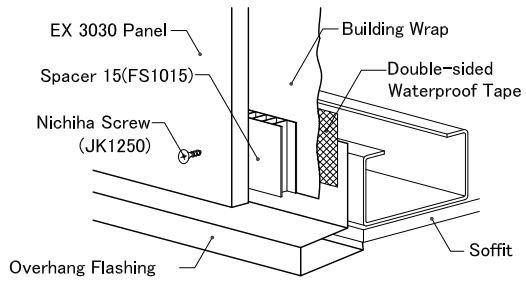

Overhang Flashing

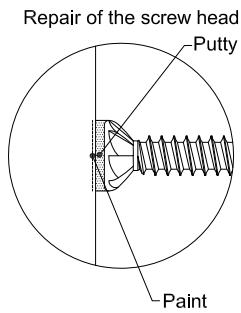
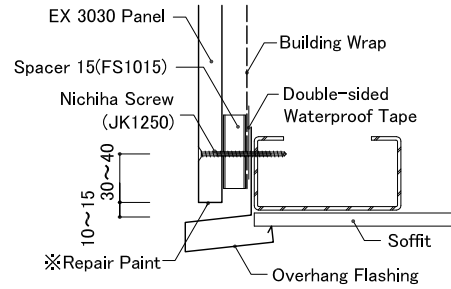

Cut Edge

Repair the cut edge of Nichiha EX. Apply sealer twice or repair coating after the sealer application with the touch-up paint.

Parapet

L-Form Cavity Vent

