

# NICHIHA EX SERIES 3030 PANEL

## HORIZONTAL INSTALLATION MANUAL

【Construction】 RC Structure

【 Substrate 】 Vertical Metal Furring Strip

Overview	
Main Member	
Base	
Horizontal Joint	Shiplap Joint Flashing
Vertical Joint	
Internal Corner	
External Corner	Pre - formed Corner
Overhang	
Soffit	
Parapet	
Openings	Top Sides Bottom

# NICHIHA EX SERIES (3030 Panel)

Substrate  
Metal Furring Strip

Furring Strip  
Vertical



Panel Installation  
Direction  
Horizontal

How to fix  
Clip  
(JE555)

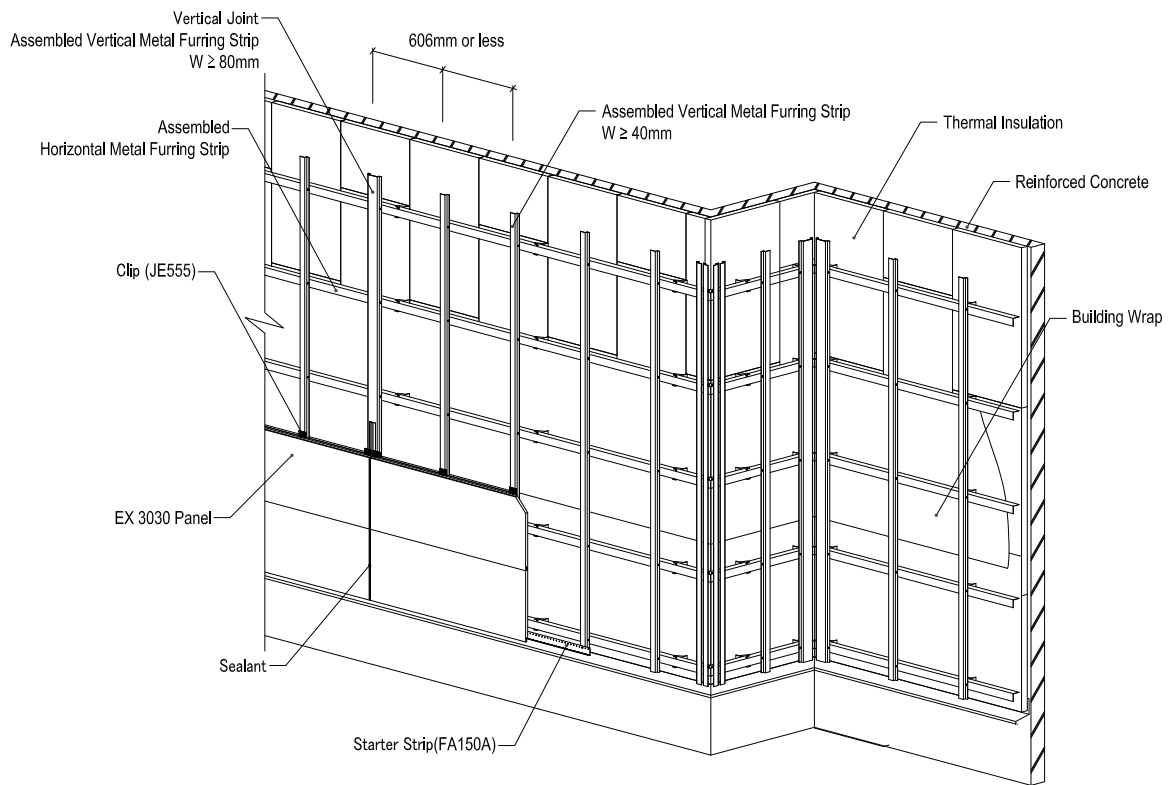
## Overview

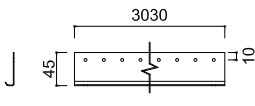
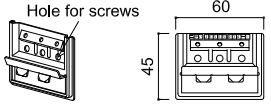
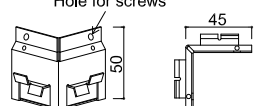

NICHHA EX SERIES (3030 Panel)	Substrate	Furring Strip	Panel Installation Direction	How to fix
	Metal Furring Strip	Vertical	Horizontal	Clip (JE555)

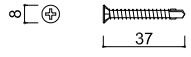
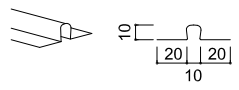
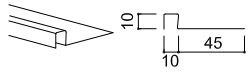
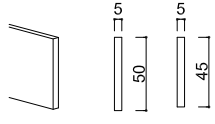
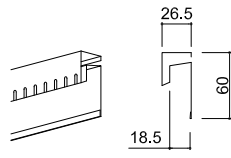
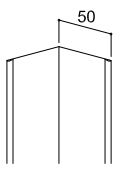
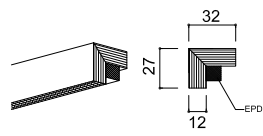
Main Accessories			
<p>■ Starter Strip</p>  <p>【FA150A】 Material: Painted 55%Al-Zn-coated steel sheet Thickness: 1.0mm Length: 3,030mm Fastening interval: @606mm or less Note: fix with Nichiha Screws</p>	<p>■ Clip</p>  <p>【JE555】 Material: Zn-11%Al-3%Mg-0.2%Si -coated steel sheet Note: fix with Nichiha Screws</p>	<p>■ L-Form Corner Clip</p>  <p>【JE550C】 Material: Zn-11%Al-3%Mg-0.2%Si -coated steel sheet Note: fix with Nichiha Screws</p>	<p>■ Nichiha Screw (for fixing Starter Strip・Clips)</p>  <p>【JK1510】 Material: Stainless Size: φ4.5mm×10mm</p>
<p>■ Nichiha Screw (for face fixing Panel)</p>  <p>【JK1520】 Material: Stainless Size: φ4.5mm×37mm</p>	<p>■ Sealant Backer Double Flange 10</p>  <p>【FH1010R】 Material: Fluoroplastic Resin Coated 55%Al-Zn-coated steel sheet Thickness: 0.3mm Length: 3,030mm</p>	<p>■ Sealant Backer Single Flange 10</p>  <p>【FHK1110R】 Material: Fluoroplastic Resin Coated 55%Al-Zn-coated steel sheet Thickness: 0.3mm Length: 2,000mm</p>	<p>■ Spacer 05</p>  <p>【FS1005】 Length: 1,200mm Material: Polypropylene  (Piece Type) 【FSP1005】 Length: 1,000mm Materials: Polypropylene</p>
<p>■ Eaves Trim 16</p>  <p>【FTM10□□】 Materials: Painted 55%Al-Zn-coated steel sheet Thickness: 0.35mm Length: 3,030mm</p>	<p>■ Internal Corner Backing</p>  <p>【JR1900】 Material: Painted 55%Al-Zn-coated steel sheet Thickness: 0.27mm Length: 3,030mm</p>	<p>■ L-Form Cavity Vent</p>  <p>【FSK1000】 Material: Polyethylene Length : 1,220mm</p>	

# NICHIHA EX SERIES

(3030 panel)

Substrate	Furring Strip	Panel Installation Direction	How to fix
Metal Furring Strip	Vertical	Horizontal	Clip (JE555)

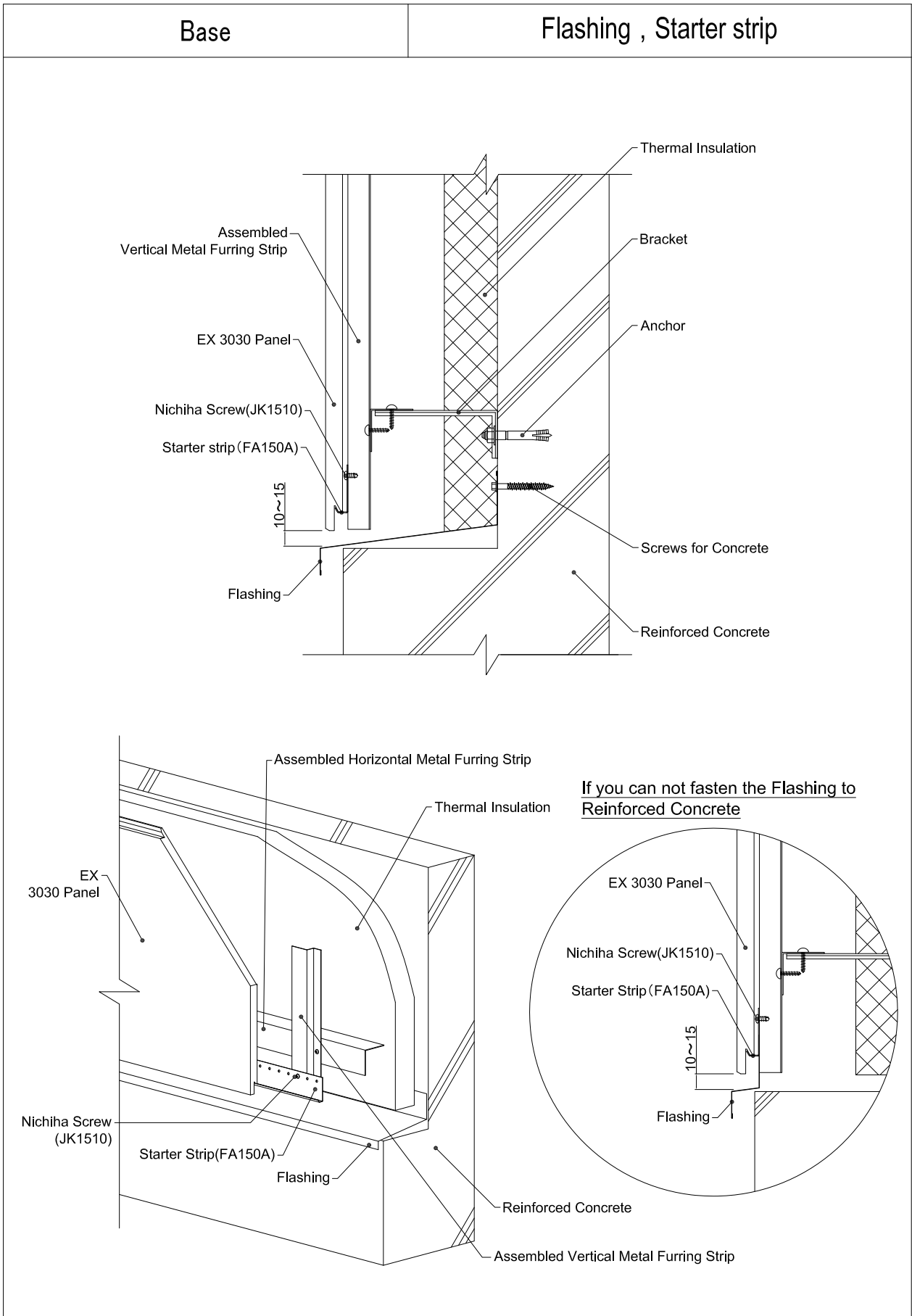



# NICHIHA EX SERIES

(3030 panel)

Substrate	Furring Strip	Panel Installation Direction	How to fix
Metal Furring Strip	Vertical	Horizontal	Clip (JE555)

## Horizontal Joint

## Flashing

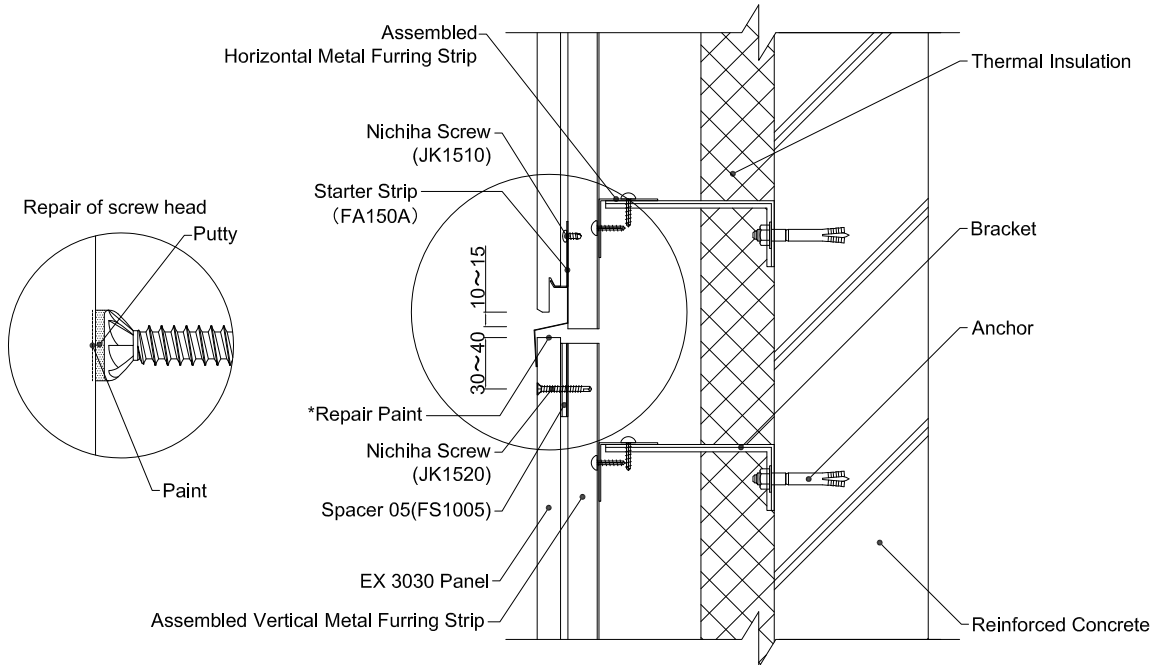

### Note

Repair the cutting edge of Nichiha EX. Apply a sealer twice or repair coating after the sealer application with the repair solution.

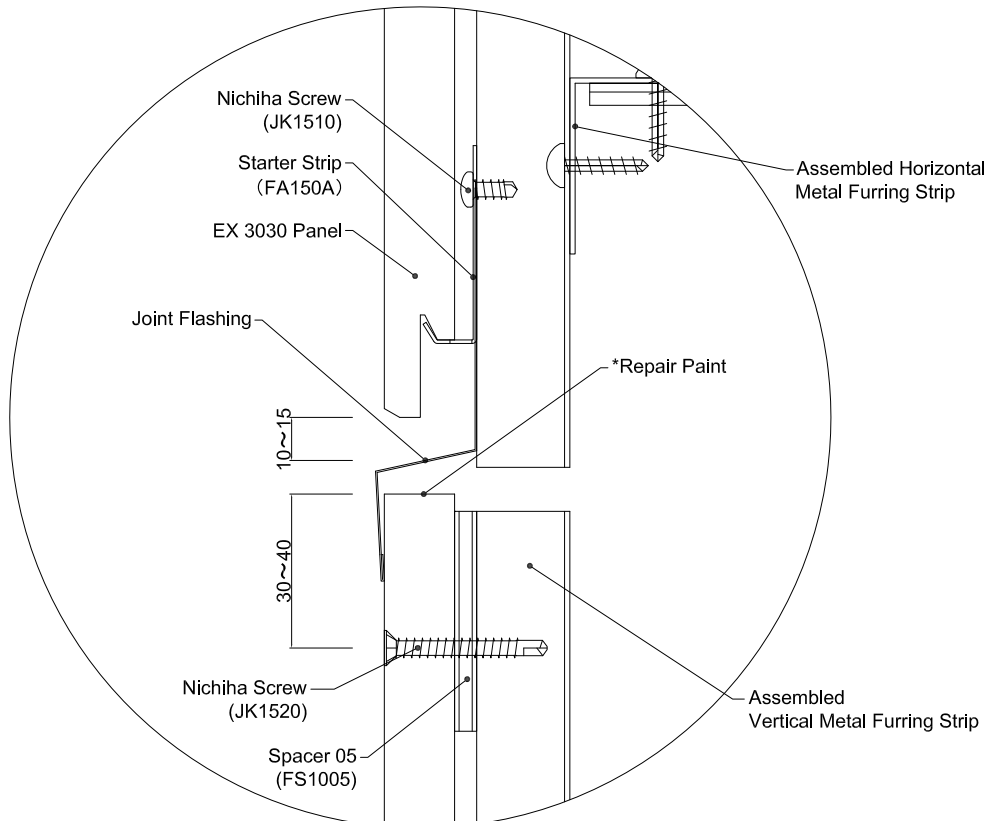

### Note

Repair the cutting edge of Nichiha EX. Apply a sealer twice or repair coating after the sealer application with the repair solution.



# NICHIHA EX SERIES (3030 Panel)

Substrate	Furring Strip	Panel Installation Direction	How to fix
Metal Furring Strip	Vertical	Horizontal	Clip (JE555)

## Internal Corner

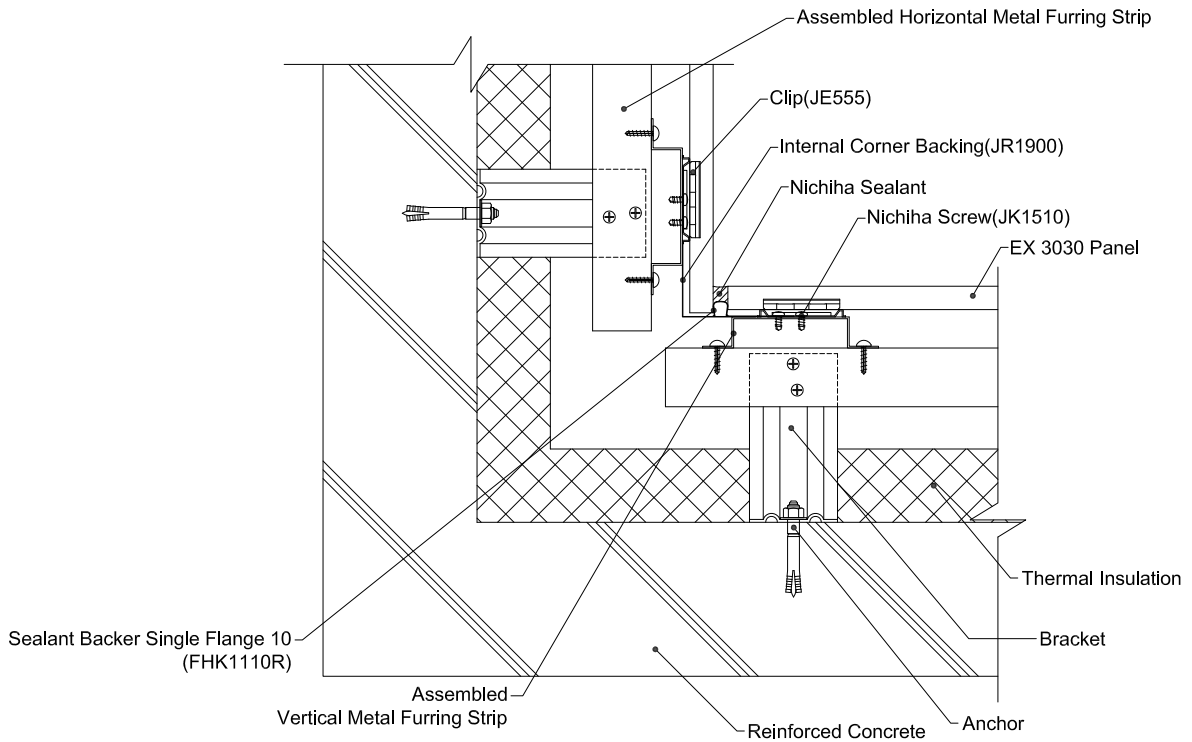

## External Corner

## Pre - formed Corner

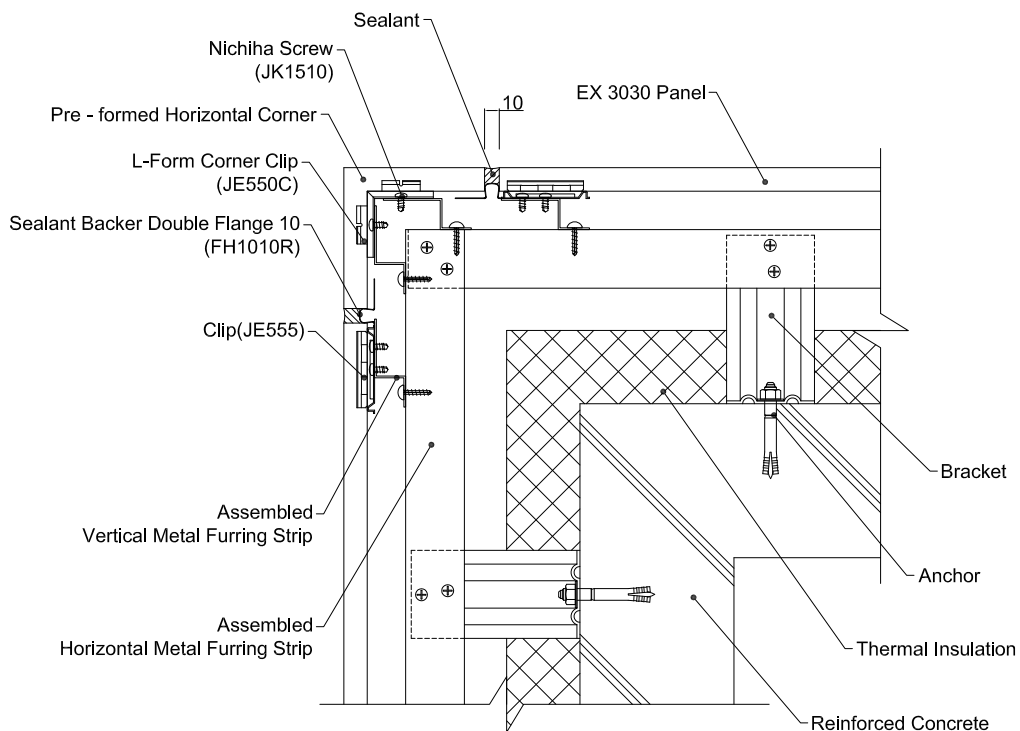



# NICHIHA EX SERIES (3030 Panel)

Substrate	Furring Strip	Panel Installation Direction	How to fix
Metal Furring Strip	Vertical	Horizontal	Clip (JE555)

## Overhang

## Flashing

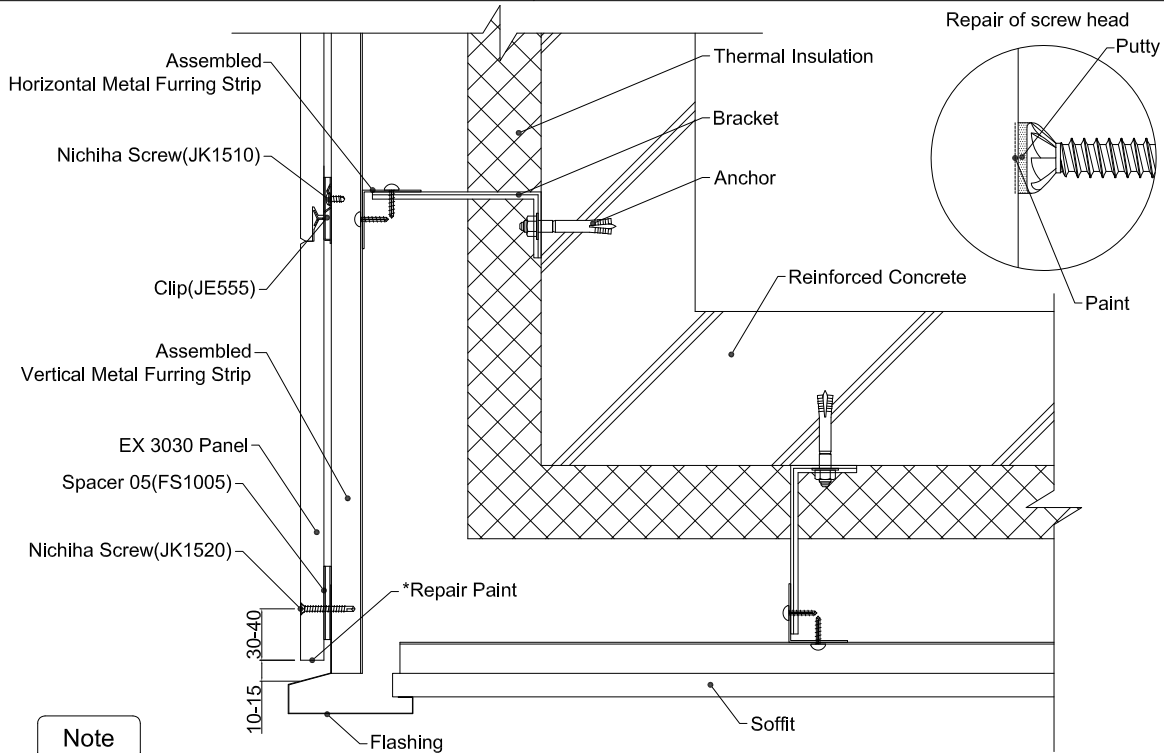

**Note**

Repair the cutting edge of Nichiha EX. Apply a sealer twice or repair coating after the sealer application with the repair solution.

## Soffit

## Eaves Trim 16

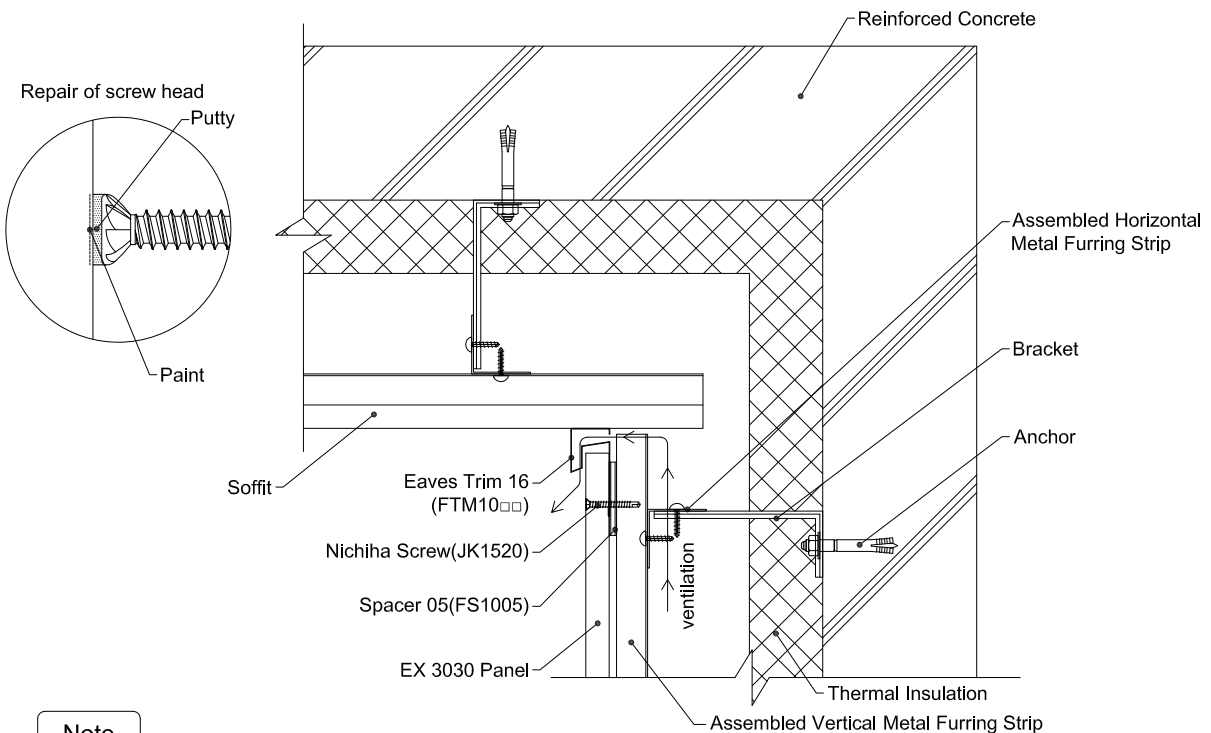

**Note**

□□ : Color numbers.

# NICHIHA EX SERIES (3030 Panel)

Substrate	Furring Strip	Panel Installation Direction	How to fix
Metal Furring Strip	Vertical	Horizontal	Clip (JE555)

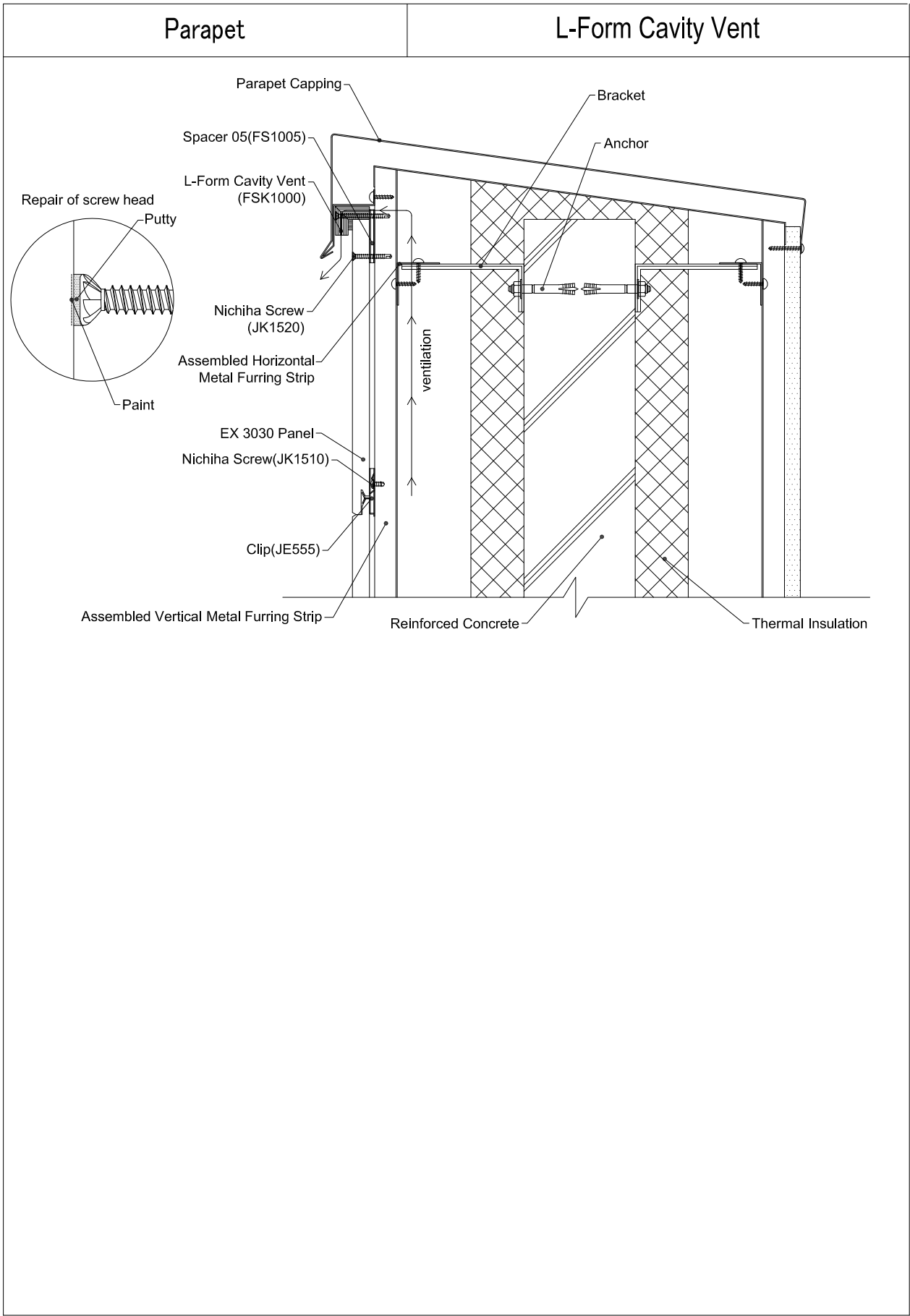

NICHHA EX SERIES (3030 Panel)	Substrate	Furring Strip	Panel Installation Direction	How to fix
	Metal Furring Strip	Vertical	Horizontal	Clip (JE555)

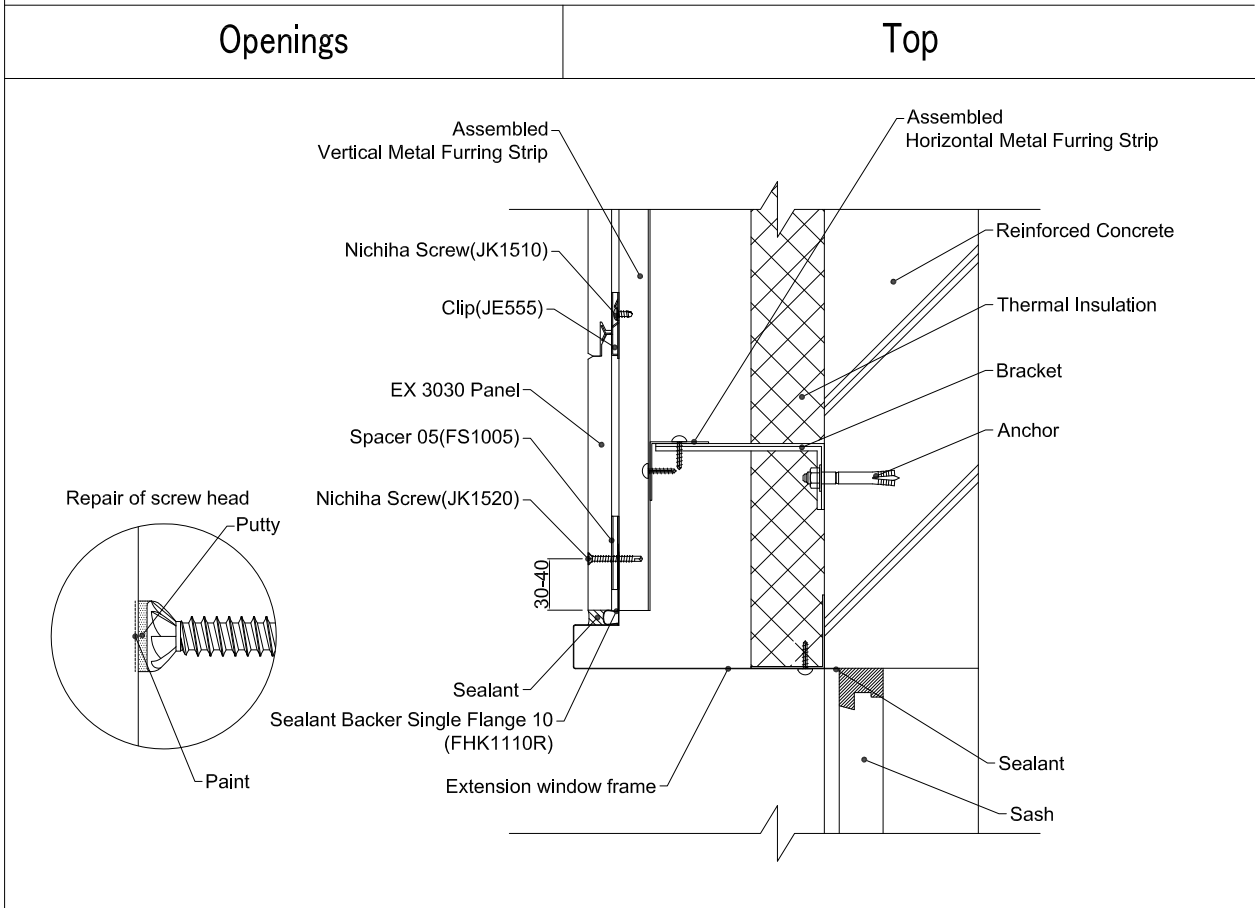
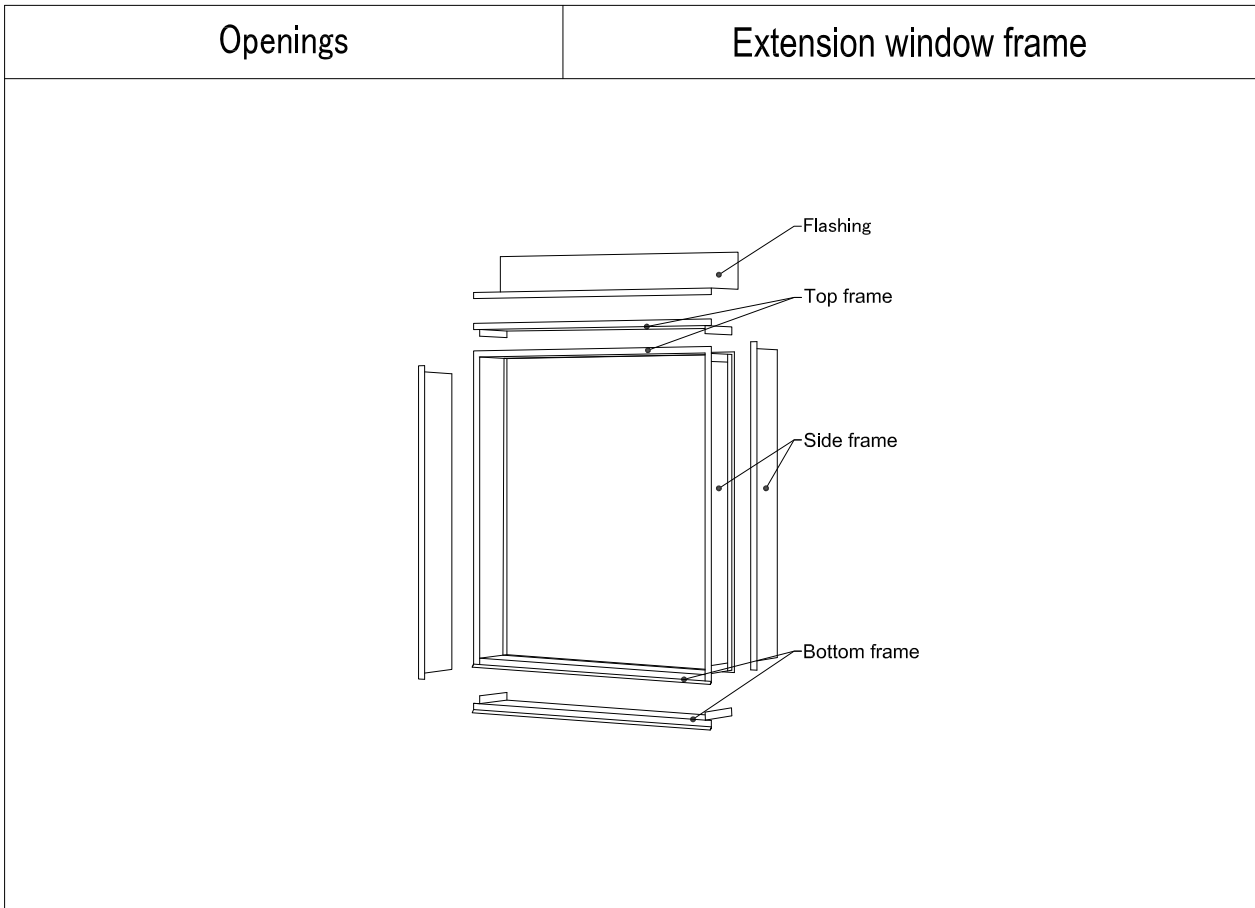

<b>NICHIHA EX SERIES</b> (3030 Panel)	Substrate	Furring Strip	Panel Installation Direction	How to fix
	Metal Furring Strip	Vertical	Horizontal	Clip (JE555)

