

*Don't just go big.
Go MEGA.*

BARD MEGA-TEC® WALL-MOUNT AIR CONDITIONER



**POWER, EFFICIENCY, FLEXIBILITY & CONVENIENCE
IN A SPACE-SAVING SPVU DESIGN**

Designed to give you high sensible cooling capacity when you have limited wall space, MEGA-TEC® is AHRI-certified and delivers industrial-grade service at the highest possible efficiency. We've built in features that respond to your needs, the weather outside and conditions in your building, making it a standout in adaptive cooling. For example, if occupancy is low or heat-generating equipment isn't running at maximum levels, the compressors can step down to less than 35% of the unit's maximum capacity. Or, if outdoor conditions are favorable, outside air can be run through the optional economizer to provide "free cooling."

All of this is contained in an exterior wall-mount, so the only interior wall space you need is for the vents. Plus, it comes with the added convenience of maintenance and service technicians not needing to enter your building to access the unit.

That kind of smart, cost-saving engineering and design can be seen throughout MEGA-TEC. Keep on reading to learn more.

WWW.BARDMEGATEC.COM



BARDHVAC.COM



Climate Control Solutions



Easy to install. Easy to service.

THE PERFECT FIT FOR YOUR RETROFIT

We designed MEGA-TEC to accommodate existing SPVU footprints and system openings, so it's the ideal slide-in replacement. Making the switch couldn't be easier, thanks to simple, two-wire daisy chain installation. Of course, it's perfect for new buildings as well.

You'll also appreciate its easy-access features. With a hinged top door and a condenser fan unit mounted on glide rails, your filter changes, coil cleaning and compressor servicing are smooth and simple.

Multi-stage cooling responds to your needs.

Thanks to dual-refrigeration circuits and three stages of cooling, this finely-tuned system can operate in partial or full load, depending on your facility's demands. It seamlessly switches between capacities for peak efficiency. The dual-circuit design with Copeland Scroll compressors provides reliable cooling performance.

Achieve incredible control with our enhanced PLC technology.

Bard developed exclusive programming for MEGA-TEC to make it as flexible as possible. Whatever your application is, whether an equipment building, data center or emergency shelter, a MEGA-TEC can cool it. Plus, you can have unrivaled control over your critical applications from a single point—even remotely.

- ▶ Control up to 14 units in three zones
- ▶ Remote access via Internet or LAN
- ▶ Bard LC6000 shelter controller can link to BardLink™ data management systems and has Modbus communication and customizable alarms
- ▶ Advanced unit diagnostics—The TEC-EYE™ user interface allows access to advanced diagnostic features





More Engineered Features

- **Logic Board Orphan Mode:**
Runs system if communication to LC controller is lost or if the controller or wiring fails.
- **High-Efficiency Indoor Blower:**
Industrial-grade centrifugal fans with backward curved blade design help achieve peak CFM airflow rates with the lowest energy usage possible.
- **High-Efficiency Outdoor Fan Motor:**
High-efficiency ECM industrial grade fan system provides optimal air flow through condenser coil, adapting to high and low outdoor temperatures.
- **Balanced Climate™:**
Bard's exclusive technology allows for efficient and effective air temperature and humidity control.
- **Optional Free Cooling:**
The factory-installed full-flow economizer option allows for free cooling savings with indoor humidity monitoring while protecting electronics with clean-air sensors.
- **Optional Coated Condensers and Evaporator Coils:**
TECHNICOAT AA offers superior corrosion resistance and protection against environmental conditions. Hydrophilic green evaporator coils come standard.
- **Optional High MERV 13 Filters:**
Achieve better air quality by trapping smaller particles like bacteria and smoke.
- **Optional Electric Reheat Dehumidification:**
Electric heat reheats the cooled, dehumidified supply air after it passes over the evaporator coils. The extended compressor runtime removes moisture from air leaving the unit.

Security, Safety and Monitoring Features

- **Outdoor Air Quality Detection System:**
During ventilation, this keeps outside dirt and debris from entering the area being cooled and extends filter life.
- **Airflow Switch:**
Monitors blower operation. Settings are field-adjustable with alarm signal.
- **Emergency Ventilation:**
Floods the building with fresh outdoor air when necessary. *Only available with economizer option*
- **High Temperature Ventilation:**
Opens economizers to vent building at alarm temperature, if outside ambient temperature is less than indoor temperature.
- **Dirty Condenser Coil Detection System:**
Monitors condenser performance with adjustable alarm notification and algorithm. *Coming soon*
- **Optional Bard Guard™:**
Theft deterrent system protects against copper and coil theft. *Coming soon*

Want to learn more?

Click the button below to register for a complimentary, online on-demand PLC training and certification module.

Register



Third Party Accreditation, Certifications and Validations

- Meets U.S. Department of Energy minimum efficiency requirements
- IECC2015
- AHRI certified
- ETL approved
- ISO 9001:2015 Certified Manufacturer

Interior Features

Non-Fiberglass Insulation:
Extremely durable and efficient closed-cell foam insulation is safer for health & the environment.

Industrial-Grade Indoor Fan:
Uses ECM technology for efficient, dependable service. Modbus communication for motor feedback.

2" Pleated Filter:
Large filter area and pleated design allow for better indoor airflow.

Refrigeration Circuits:
Two separate refrigeration circuits use individual compressors for serviceability and reliability.

Fan Pressure Switch:
Indicates blower failure. Standard on all models.

Industrial-Grade Controls:
Control panel is clean, organized and easy to service.

Electronic Expansion Valves:
Allows for precise superheat control. Certified in accordance with national and international standards for intelligent refrigerant metering. The Bard EEV has passed rate tests in one billion+ cycles.

Phase Monitor:
Protects against compressor reverse rotation and irregular voltage conditions. Standard on all three-phase models.

PLC Technology:
Control board uses Modbus to communicate with components and controller.

Liquid Line Filter/Dryer:
Filter dryers protect refrigeration equipment and are standard in all models.

Industrial-Grade Outdoor Fan:
Outdoor fan uses ECM technology for efficient, dependable service. Modbus communication used for motor feedback.

Pressure Transducers:
Constantly monitors high and low side system refrigeration pressures and alerts if they fall outside designated levels. Continuously calculates and displays subcooling and superheat.

Slide-Out Fan Assembly:
Glide rails allow fan to be pulled forward. Hinges allow fan to be rotated out of the way for compressor access.

Scroll Compressors:
Each refrigeration circuit uses a separate scroll compressor. Three cooling stages provide efficient capacity control for applications with lower heat loads.

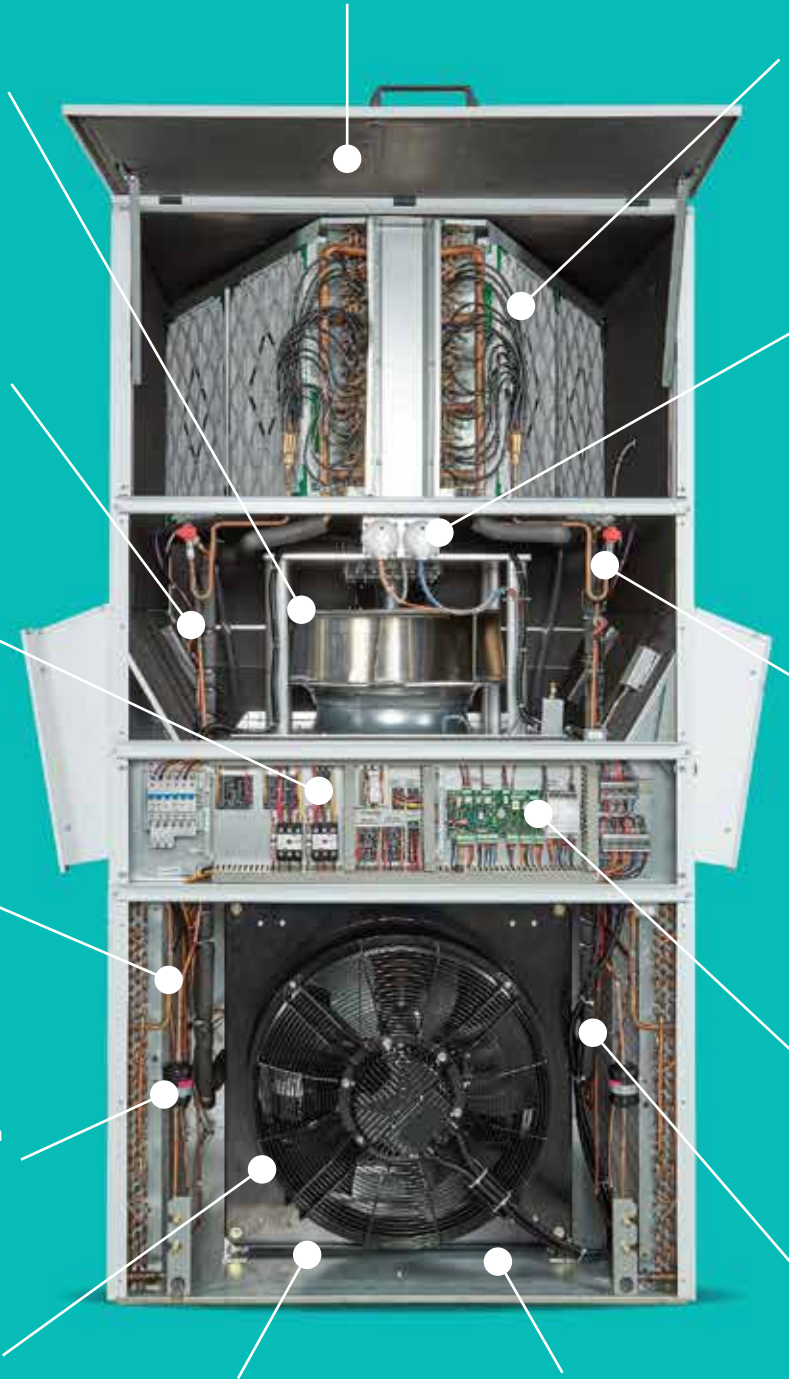

Exterior Features

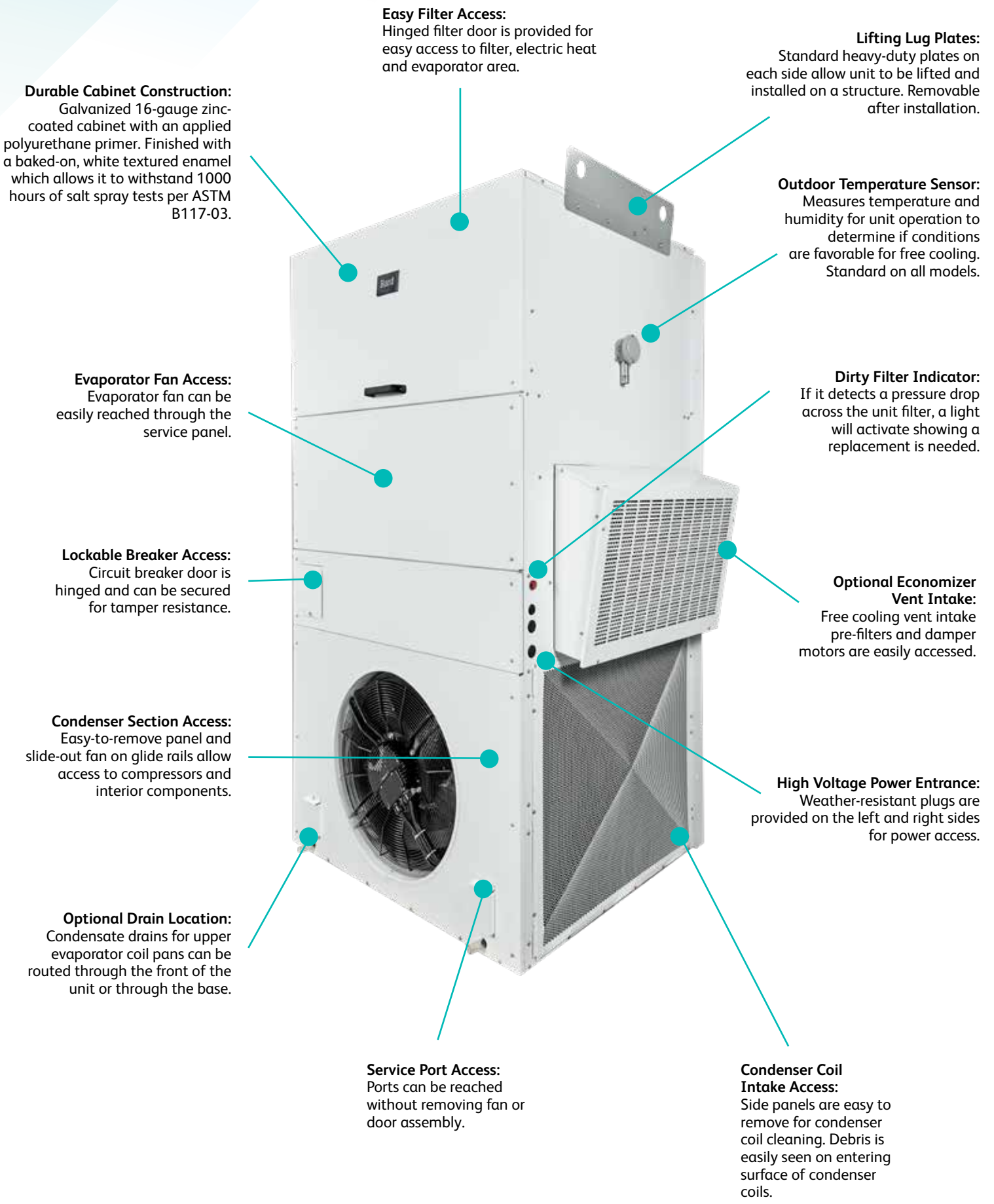

Durable Cabinet Construction:
Galvanized 16-gauge zinc-coated cabinet with an applied polyurethane primer. Finished with a baked-on, white textured enamel which allows it to withstand 1000 hours of salt spray tests per ASTM B117-03.

Easy Filter Access:
Hinged filter door is provided for easy access to filter, electric heat and evaporator area.

Lifting Lug Plates:
Standard heavy-duty plates on each side allow unit to be lifted and installed on a structure. Removable after installation.

Evaporator Fan Access:
Evaporator fan can be easily reached through the service panel.

Outdoor Temperature Sensor:
Measures temperature and humidity for unit operation to determine if conditions are favorable for free cooling. Standard on all models.

Lockable Breaker Access:
Circuit breaker door is hinged and can be secured for tamper resistance.

Dirty Filter Indicator:
If it detects a pressure drop across the unit filter, a light will activate showing a replacement is needed.

Condenser Section Access:
Easy-to-remove panel and slide-out fan on glide rails allow access to compressors and interior components.

Optional Economizer Vent Intake:
Free cooling vent intake pre-filters and damper motors are easily accessed.

Optional Drain Location:
Condensate drains for upper evaporator coil pans can be routed through the front of the unit or through the base.

High Voltage Power Entrance:
Weather-resistant plugs are provided on the left and right sides for power access.

Service Port Access:
Ports can be reached without removing fan or door assembly.

Condenser Coil Intake Access:
Side panels are easy to remove for condenser coil cleaning. Debris is easily seen on entering surface of condenser coils.

Save money with free cooling.

With our optional economizer on MEGA-TEC; you can achieve extremely high cooling efficiencies by taking advantage of cooler outdoor conditions in a process called “free cooling.” Outside air is brought in through hoods located on both sides of the unit. Economizer operation allows for free cooling at outdoor temperatures down to -40°F.



Side View

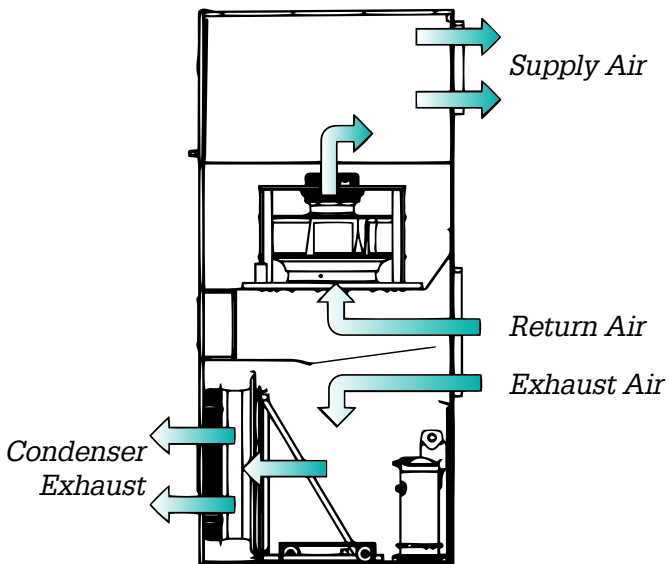

Front View

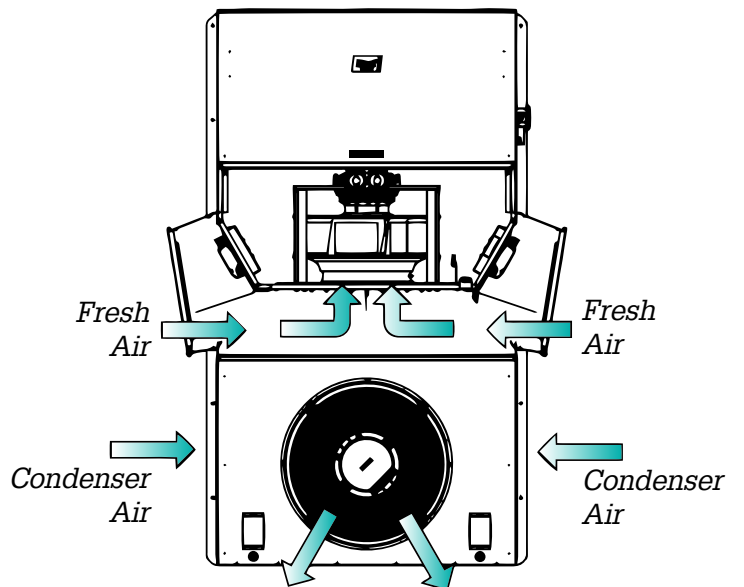



Dedicated Equipment Building

Structures like this house critical equipment for nearby facilities, including telecommunications and computer systems (see below). Because clients like this can't afford to suffer outages, they also often utilize uninterrupted power supplies.

That kind of technology generates a lot of heat, classifying them as high-density. MEGA-TEC offers an effective way to cool down the space without requiring a lot of indoor space.

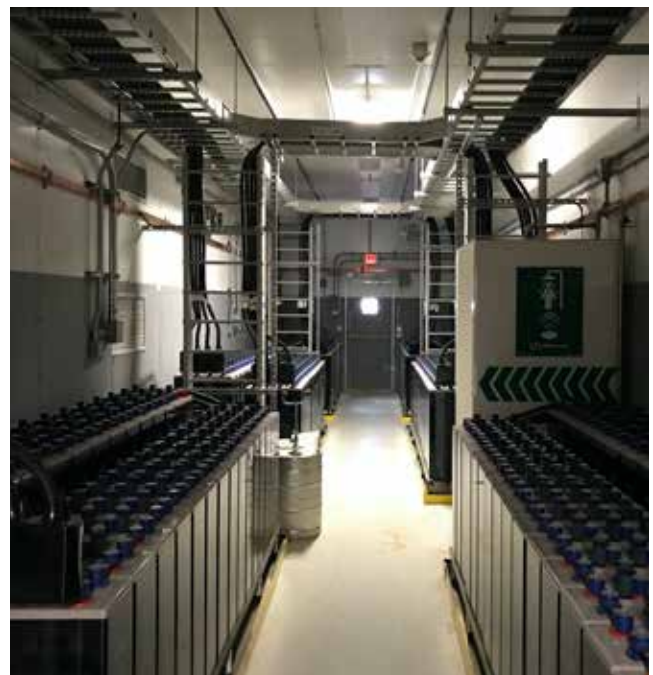

Data Centers ▶

These types of buildings can be found almost anywhere in the world—meaning every climate. MEGA-TEC is ideal no matter where it is, because it's engineered to adapt to all kinds of outside conditions. Built-in features respond to humidity, cold and hot temperatures. These photos show MEGA-TEC in action in the tropical climate of Miami, Florida, as well as the frozen winter of Fairport, New York—just outside Rochester.



◀ Electrical Equipment Room

Here's an example of MEGA-TEC cooling an essential area of a large building. These units are technically on the exterior of the building, but they're not outdoors—they're near the parking garage. Because MEGA-TEC has such a large capacity, just one unit is needed, but the client decided to install an additional unit for redundancy. The bottom image shows the vents inside the building. You can see a very minimal amount of wall space is needed.





◀ **Modular Equipment Building for Remote & Offsite Locations**

MEGA-TEC is particularly well-suited for the mining and petrochemical industries, or any other applications where a lot of technology is needed in temporary, isolated locations. Here, MEGA-TEC units are being installed on an electrical equipment room for a mining company in South America. Since facilities like this are typically not very big, it helps to have a/c units that don't require a lot of interior wall space. And since installation is straightforward, it's easy to incorporate MEGA-TEC into the space, even if it's in a very remote area.

Breathe easy. You've got Bard.

Don't take our word for it—see the benefits of MEGA-TEC yourself. Specify MEGA-TEC on your next project or ask for it to be included on your next quote. For more information, contact your Bard sales representative or email sales@bardhvac.com.



Bard Manufacturing Company, Inc.
1914 Randolph Dr., Bryan, OH 43506
419-636-1194

www.bardhvac.com

January 2021 | S3617