

## Installation Guide | Center Levered Bracket

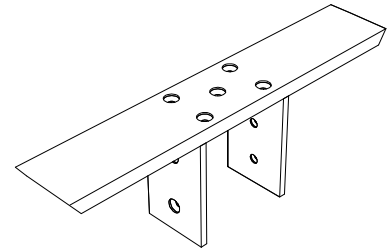
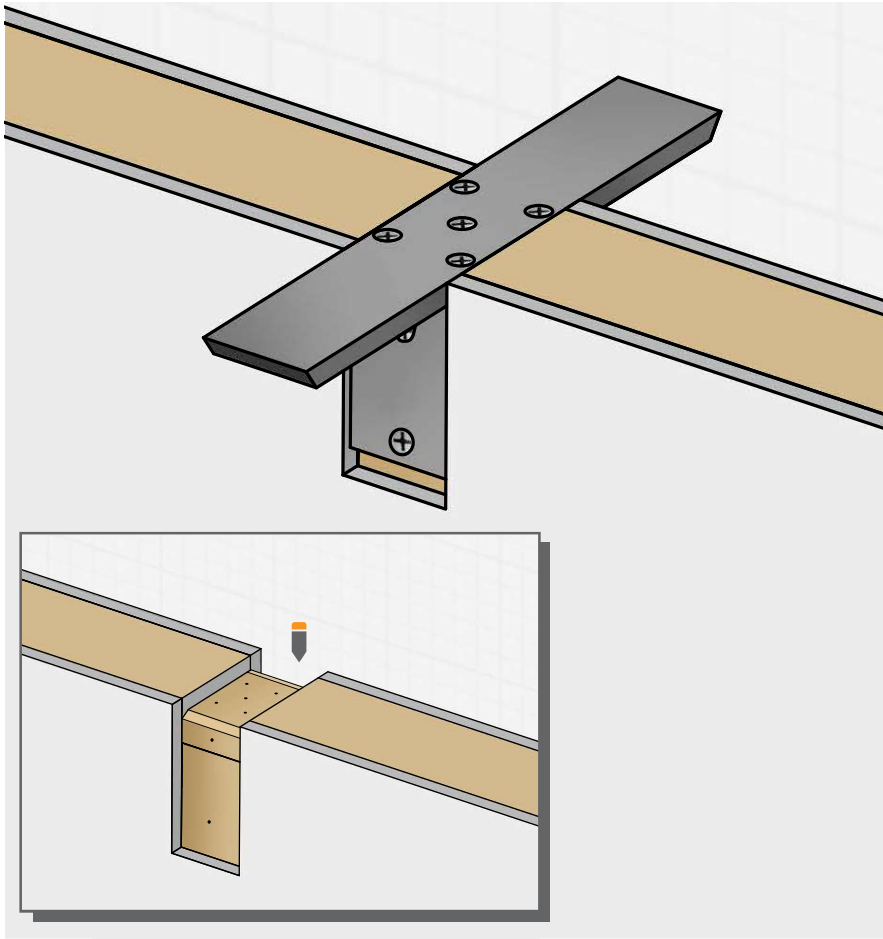

1. Measure and mark the appropriate mounting locations over a vertical stud on the cap of your knee wall. Start at 6" in from the edges and space remaining brackets on each stud, as needed.
  2. Create mounting channel for bracket:
    - A. **POWER TOOLS:** Use a top-bearing flush trim router with a ½" deep cutting length and trim the excess wood out of the mounting surface.
    - B. **MANUAL TOOLS:** Use a hand saw and cut along each line to a depth of ½". Then use a wood chisel (1" is a good choice) to remove the excess wood between the lines you just created.

Be sure to remove all the material in the mounting channel so you have a clean, level channel for the bracket to be seated in. Chamfer the edges to accommodate the weld bead.
  3. Place the bracket into the mounting channel and use a level to ensure the brackets are level with the knee wall. If necessary, use shims to make the bracket level.
  4. Affix the bracket to the cap and studs using **ALL** of the included #12 wood screws. The bracket should fit snugly against the stud.
- HINT:** Pre-drill holes in advance using a 9/64" bit. This will help ensure the wood doesn't split.
5. Prior to setting the top in place, run a bead of high-quality silicone adhesive down the center of each bracket.