

PLANK[®]



BENCH

Konstantin Grcic

BENCH

Konstantin Grcic

BENCH

Konstantin Grcic

Superare confini creativi senza perdere d'occhio la produzione industriale.

Questa è il filo conduttore che accomuna tutti i progetti di Konstantin Grcic per PLANK.

Nel caso di BENCH, il punto di partenza è una modesta trave di legno. Ripiegando i lati, emergono le gambe e quindi l'archetipo di una panchina.

Apparentemente semplice, nei fatti altamente complesso.

Un meccanismo appositamente inventato collega la seduta con le gambe per un montaggio semplice, rapido e senza attrezzi. Il tavolo BENCH table nasce dallo stesso principio della panca e la completa in modo armonioso. Mentre la panca è determinata nella sua dimensione e forma, i tavoli possono essere configurati in diversi formati e diverse posizioni delle gambe.

La semplicità senza tempo di questo design permette a BENCH di adattarsi a diversi campi di applicazione - pubblico e domestico, tradizionale e moderno, semplice ed elegante.

La scelta dell'abete rosso, proveniente dalle vicinanze, è stata evidente fin dall'inizio. Questo legno massiccio si rifà alle radici di PLANK che nasce come manifattura di sedie tipiche della regione alpina. Enfatizza la dedizione di PLANK ad un'etica sostenibile e allo stesso momento rappresenta un elemento di qualità che migliora in bellezza e personalità con il tempo. BENCH connette - persone, posti e prospettive.

Pushing creative boundaries while keeping an eye on industrialization.

This simple formula could characterise the long-standing partnership between PLANK and Konstantin Grcic. 2022 sees the launch of their newest creations, BENCH and BENCH table.

The starting point of this project was a plain wooden beam to sit on. Extending both ends of the beam down to the floor creates the legs of a simple bench. The inverted U-shape looks familiar, were it not for a special detail. Seat and legs are plugged together by means of an invisible pin connection, which requires no tools for assembly or disassembly.

BENCH table was developed on the same construction principle and complements the bench harmoniously. While the bench is determined in its dimension and shape, the tables can be configured in different formats and leg positions. The timeless simplicity of the design allows BENCH and BENCH table to adapt to many different environments - public and domestic, traditional and modern, simple and elegant. The use of spruce wood, sourced from a local forestry, was a deliberate choice. It pays tribute to PLANK's legacy as manufacturer of traditional alpine chairs. It also stands for a timeless and long-lasting solution, which expresses PLANK's uncompromising dedication to the objectives of sustainability.

BENCH connects - people, places, perspectives.



BENCH BENCH table

Konstantin Grcic

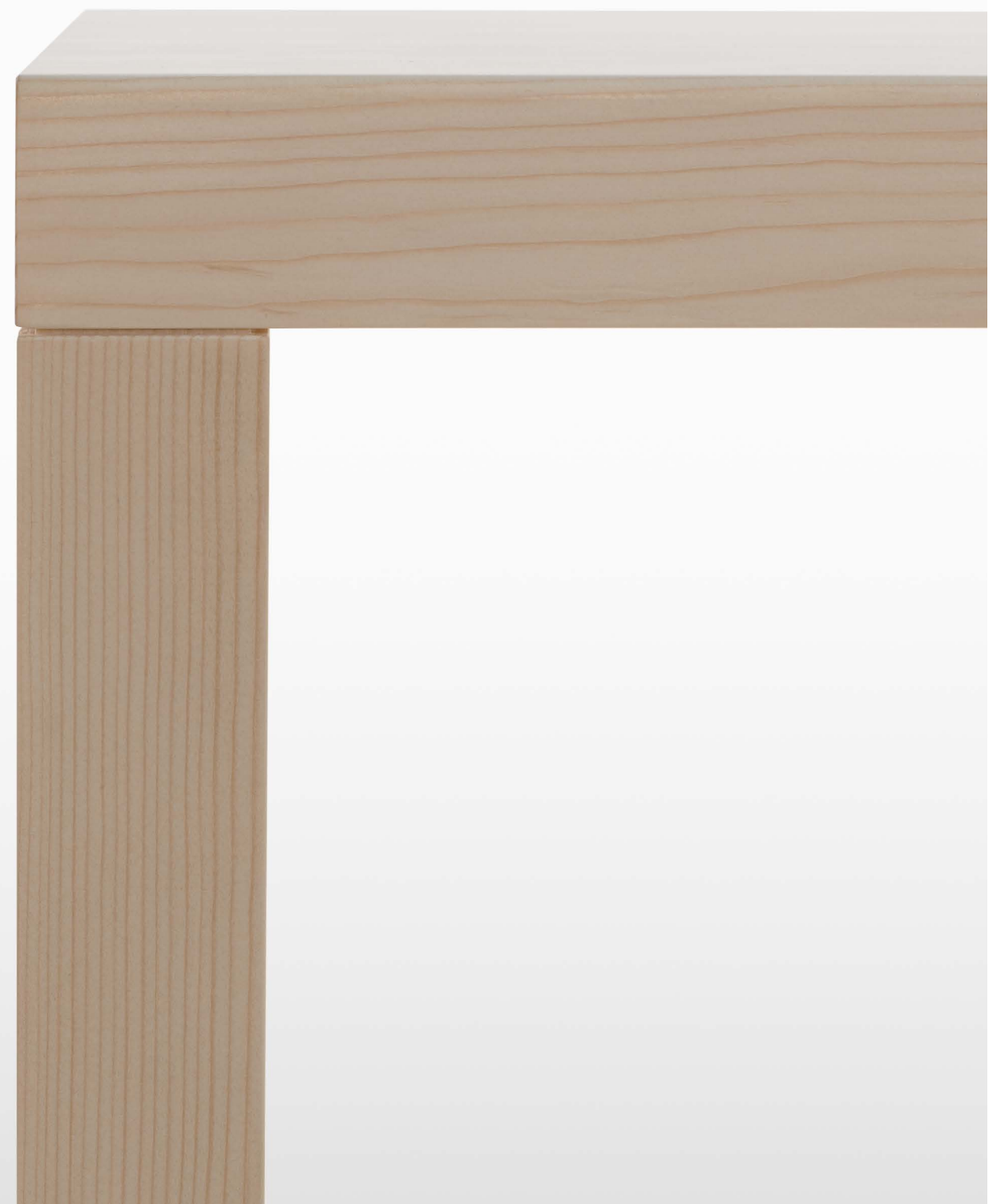



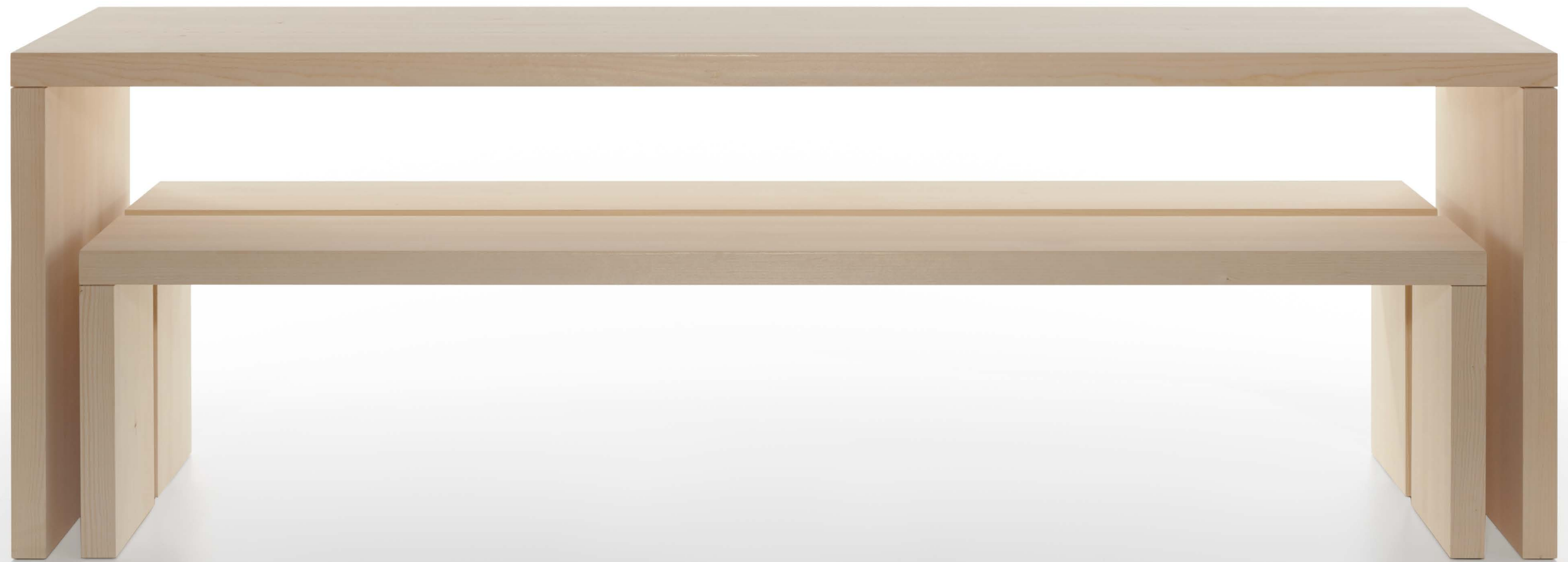





BENCH mechanism



BENCH table configurations



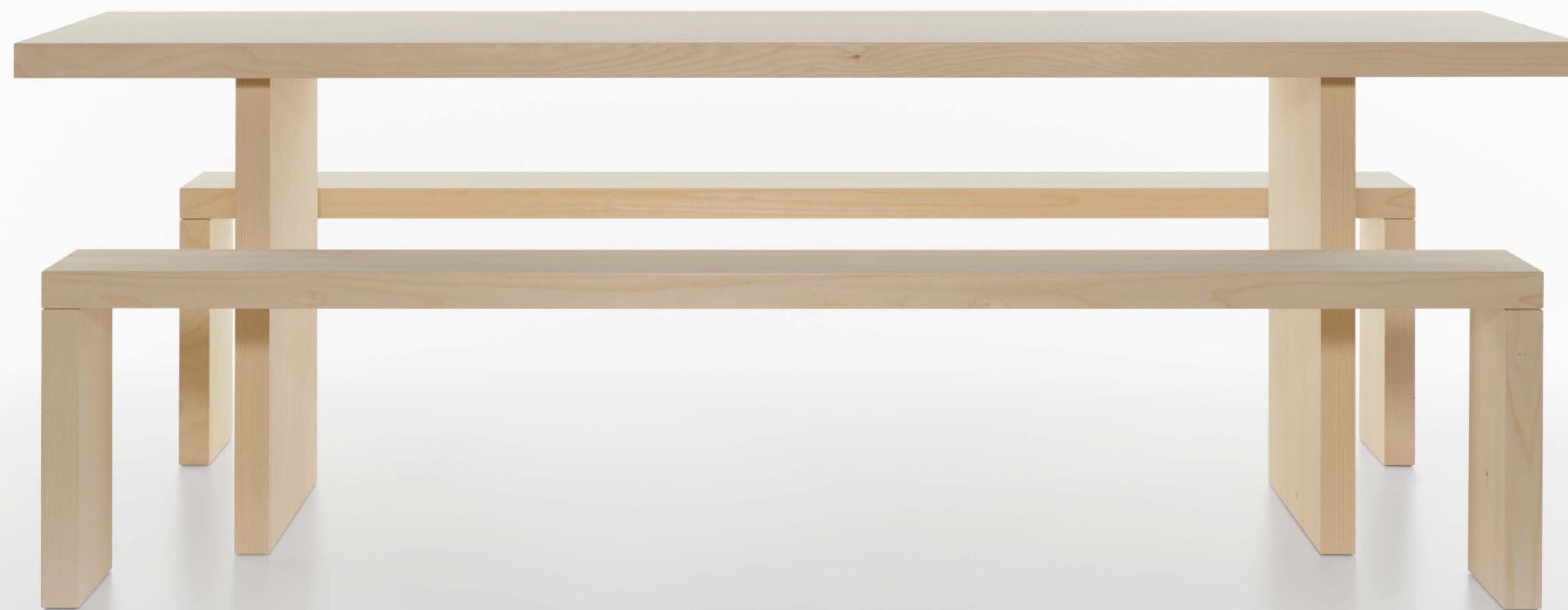









BENCH design Konstantin Grcic

Mod. 0628-01

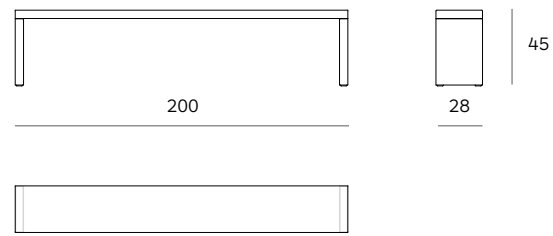

Seduta e fianchi in legno massiccio, abete oliato naturale. Collegamento degli elementi di legno con un sistema di montaggio rapido. Scivoli di plastica o di feltro.

Seat and sides in solid wood, spruce oiled. Wood elements connected by a quick assembly system. Glides in plastic or felt.

Sitzfläche und Seitenwangen in Massivholz, Fichte geölt. Verbindung der Holzelemente durch ein Schnell-Montage System. Gleiter aus Kunststoff oder Filz.

Finiture legno / Wooden finishings / Holzausführungen
Abete / spruce / Fichte



naturale, natural, natur

BENCH table design Konstantin Grcic

Mod. 0660-01

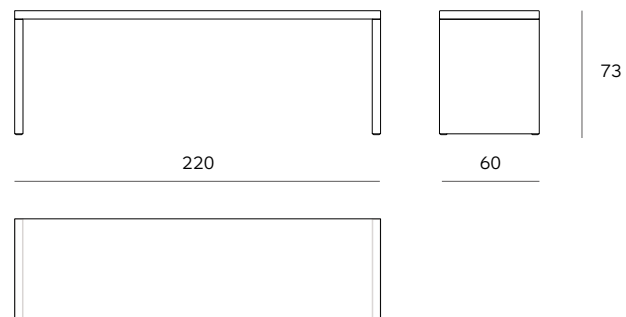

Mod. 0661-01

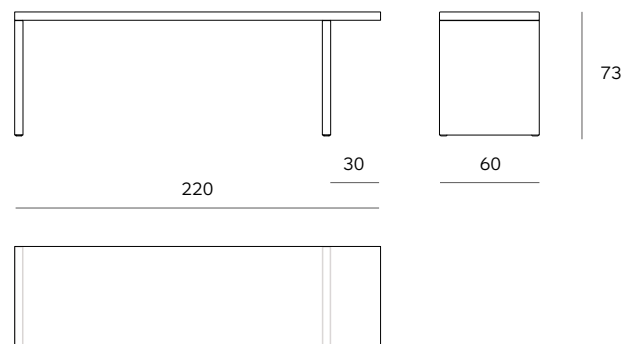

Mod. 0662-01

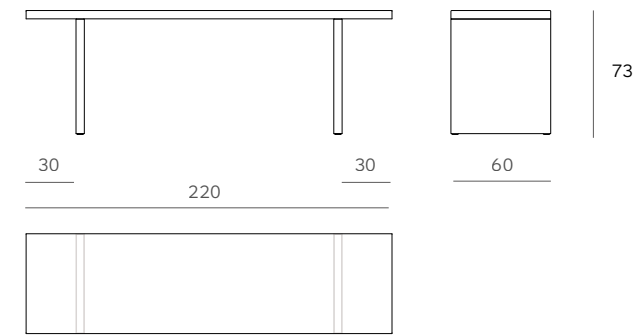

Piano tavolo e fianchi in legno massiccio, abete oliato. Collegamento degli elementi di legno con un sistema di montaggio rapido. Scivoli di plastica o di feltro.

Table top and sides in solid wood, spruce oiled. Wood elements connected by a quick assembly system. Glides in plastic or felt.

Finiture legno / Wooden finishings / Holzausführungen
Abete / spruce / Fichte



naturale, natural, natur

Mod. 0682-01

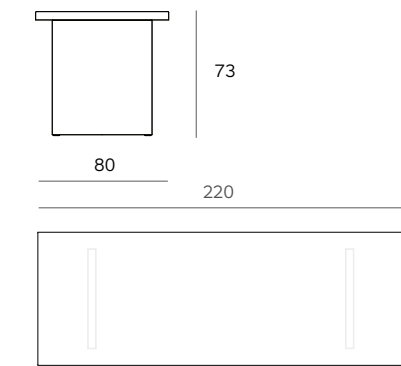

Tischplatte und Seitenwangen in Massivholz, Fichte geölt. Verbindung der Holzelemente durch ein Schnell-Montage System. Gleiter aus Kunststoff oder Filz.

Scivoli / glides / Gleiter



Scivolo plastica
Plastic glides
Kunststoffgleiter



Scivolo feltro
Felt glides
Filzgleiter

Art Direction:
Biagio Cisotti

Graphic Design:
Sandra Laube

Photography:
Miro Zagnoli

Printed in Italy on environmentally friendly paper, May 2022.

Plank Srl
Via Nazionale 35
I-39040 Ora (BZ)
Tel +39 0471 803 500
info@plank.it
www.plank.it

Quality system according to ISO 9001
© 2022 Plank Srl - All Products International Deposit of Industrial Design

Plank Srl
Via Nazionale 35
I-39040 Ora (BZ)
Tel +39 0471 803 500
info@plank.it
www.plank.it