



atech.

Du mobilier de végétalisation français à votre mesure

Edition 2023

**AMÉNAGEONS
ENSEMBLE
LA NATURE EN VILLE !**



L'environnement est aujourd'hui au cœur de toutes les préoccupations. Surchauffe urbaine, pollution de l'air, bruit... la Cité est l'un des symboles des enjeux collectifs pour un futur et une qualité de vie durables.

Une enquête menée en 2020, par L'Observatoire des Villes Vertes, avant les élections municipales, montrait que huit Français sur dix demandaient aux futurs élus d'accorder plus d'importance aux espaces verts. Soit une progression de 33% par rapport au même sondage, réalisé en 2016.

En décembre 2021, une étude, toujours réalisée par cet Observatoire, établissait une corrélation entre le végétal et la santé publique.

Métallier français depuis plus de 35 ans, ATECH s'est engagé - dès l'origine - en faveur de la végétalisation des villes. Collectivités... nous vous accompagnons au quotidien pour répondre tant à vos attentes que celles de vos concitoyens. A vos côtés, nous allons chaque jour plus loin.

VERS UNE PRODUCTION CIRCULAIRE

Notre démarche RSE se structure notamment autour de la gestion de l'eau, la réduction de l'impact carbone et une approche de l'économie circulaire.

- **Gestion de l'eau** car cette ressource est précieuse ! Les trois quarts des bacs et pots de notre catalogue sont équipés de réservoirs d'eau. ATECH souhaite aussi innover, en nouant par exemple un partenariat avec la startup Vertuo dont l'une des solutions permet de récupérer les eaux pluviales depuis les toitures.
- Réduction du CO2 en phase avec les actions des entreprises et des collectivités pour le climat en vue d'une baisse des émissions de Gaz à Effet de Serre (GES) de 40% d'ici 2030. ATECH a effectué en 2022 son 2^e bilan carbone pour valider les résultats des actions menées.
- Economie Circulaire pour la création progressive d'une filière du recyclage en mesure d'aller vers une production de plus en plus vertueuse : nos pots en plastique présentant des défauts sont déjà broyés pour fournir 100% de la matière première de nos bacs de culture ; nos balconnières et suspensions intègrent désormais 30% de déchets d'huîtres. Le métal, notre matériau ADN, est recyclable à l'infini.

ADAPTER ET TRANSPOSER NOTRE SAVOIR-FAIRE

En 2021, nous avons collaboré avec Alexis Tricoire, donnant naissance à la gamme de mobilier urbain Mosaique. Nouveau partenariat, cette année, avec ce designer de renom, lauréat d'un appel à projets pour la Paris Design Week, en septembre 2022, autour d'un îlot de fraîcheur à la structure en bois recyclé issu d'anciens châssis de fenêtres.

Un prototype, baptisé FreshCity, en forme de parabole de l'évolution d'ATECH qui adapte en permanence son savoir-faire historique de métallier et le transpose à de nouveaux matériaux pour répondre aux défis à relever.

Today, the environment is a priority for everyone. Urban overheating, air pollution, noise... City living represents collective challenges we must face for a sustainable future and quality of life.

A survey, conducted in 2020 by the Green Cities Observatory before France's municipal elections showed that eight out of ten French people wanted their future elected representative to give more importance to green spaces. Compared to the same survey in 2016, this is an increase of 33%.

In December 2021, a study also carried out by this Observatory established a correlation between plants and public health.

As a French metal manufacturer for over 35 years, ATECH has been committed to making cities greener since its very beginning. We support local authorities on a daily basis to meet your expectations and those of your fellow citizens. By your side, we are going further every day.

CIRCULAR PRODUCTION

Our CSR approach is structured around water management, carbon footprint reduction and the circular economy.

- **Water management** because water is a precious resource! Three quarters of the planters and pots in our catalogue are equipped with water reservoirs. ATECH also wants to innovate, for example through a partnership with start-up Vertuo whose solutions include the recovery of rainwater from roofs.
- Reduction of CO2 in line with climate actions by companies and communities with a view to reduce greenhouse gas (GHG) emissions by 40% by 2030. In 2022, ATECH carried out its 2nd carbon assessment to confirm the results of the actions already taken.
- Our Circular Economy approach is progressively helping to create recycling that is moving us towards increasingly virtuous production. Already today, our defective plastic pots are crushed to provide 100% of the raw material for our culture tubs, and our window boxes and hanging baskets are now made with 30% oyster waste. Metal, our defining material and our DNA, is infinitely recyclable.

ADAPTING AND TRANSPOSING OUR EXPERTISE

In 2021, we collaborated with Alexis Tricoire and created the Mosaique range of street furniture. This year we have a new partnership with this celebrated designer which won a project proposal for Paris Design Week in September 2022. Together we have created an island of freshness with a structure made of recycled wood from old window frames.

A prototype called FreshCity represents ATECH and its evolution, how it is constantly adapting its historical metal expertise and transposing it to new materials to meet the challenges ahead.



**FABRIQU'É
EN FRANCE**

AMÉNAGER LA NATURE EN VILLE

LANDSCAPING NATURE IN THE CITY

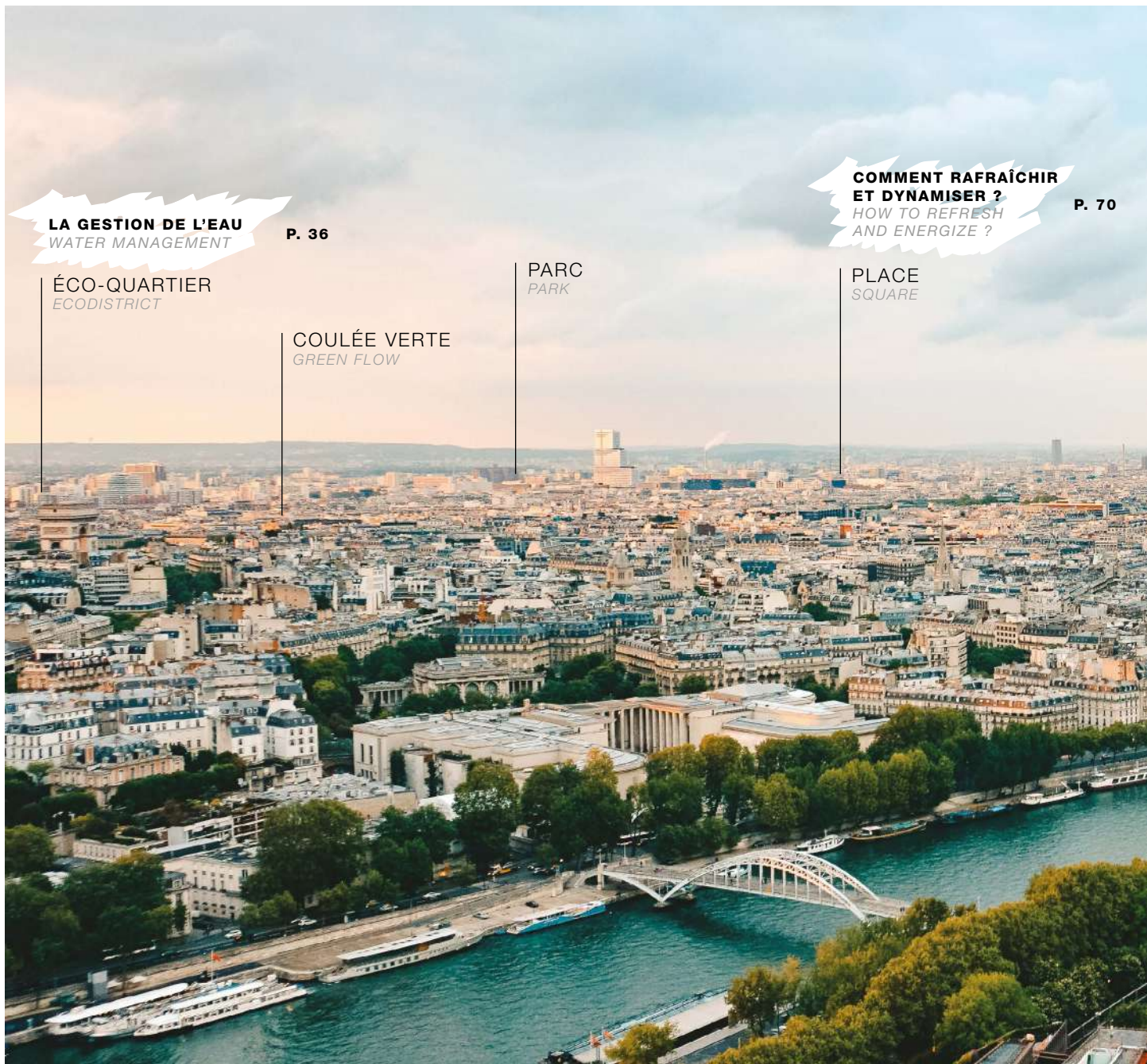

6 BACS DE FLEURISSEMENT
PLANTERS

40 POTS DE FLEURS
FLOWER POTS

**COMMENT VÉGÉTALISER
ET CRÉER DES ZONES D'OMBRE ?**
HOW VEGETALIZING
AND CREATING SHADOW AREAS ?

P. 72

ÉCOLE
SCHOOL

RIVE
BANK

LA GESTION DES PIEDS D'ARBRE P. 88
TREE FOOT MANAGEMENT

VOIRIE
ROAD



52 JARDINS URBAINS
URBAN GARDENS

74 ASSISES
SEATS

86 PRODUITS COMPLÉMENTAIRES
ADDITIONAL PRODUCTS



BACS DE FLEURISSEMENT

PLANTERS

Nos bacs de fleurissement vont vous permettre de végétaliser les espaces urbains et ce en toute tranquillité. Au fil des pages vous découvrirez des macarons bleus qui indiquent la présence d'une **réserve d'eau** au sein du bac.

Il vous sera possible de personnaliser ces contenants avec une couleur, une découpe laser ou bien une matière différente. **ATECH** s'adapte à chaque besoin.

*Our planters will allow you to green urban spaces peacefully. Over the pages you will find blue buttons which indicate that there is a **water reserve** inside the planter. You will be able to customize these planters with a color, a laser cut or a different material. **ATECH** adapts to each need.*



Fiche

technique

ORIGAMI

Bac : Aluminium peint, pieds réglables | **Bac de culture** : Bac de culture noir en plastique recyclé p. 32 | **Options** : Manutention par transpalette (ajout de cache-pieds), Système de levage pour bac de culture p. 32-33

Planter : Hot lacquered aluminium, adjustable feet | **Planting liner** : Planting liner colour black in recycled plastic p. 32 | **Options** : Moveable by pallet jack (addition of grooming), Lifting system for planting liner p. 32-33

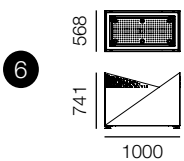
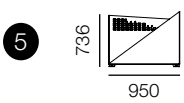
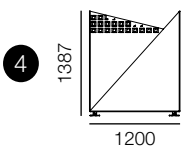
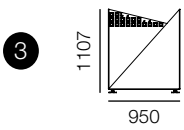
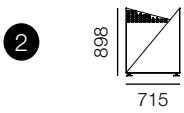
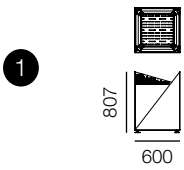

Crêches-sur-Saône (71)

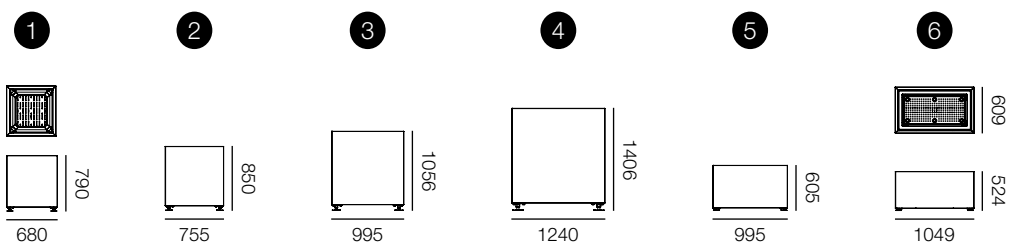

Ailly-sur-Noye (80)
Option système de levage pour bac de culture
Option lifting system for planting liner



St-Avertin (37)
Option manutention par transpalette et système de levage
Option moveable by pallet jack and lifting system

Bac : Acier peint, pieds réglables | **Bac de culture** : Bac de culture noir en plastique recyclé p. 32 | **Options** : Manutention par transpalette (ajout de cache-pieds), Système de levage pour bac de culture p. 32-33

Planter : Hot lacquered steel, adjustable feet | *Planting liner* : Planting liner colour black in recycled plastic p. 32 | **Options** : Moveable by pallet jack (addition of grooming), Lifting system for planting liner p. 32-33

Cube



technique

Fiche



Fiche

technique

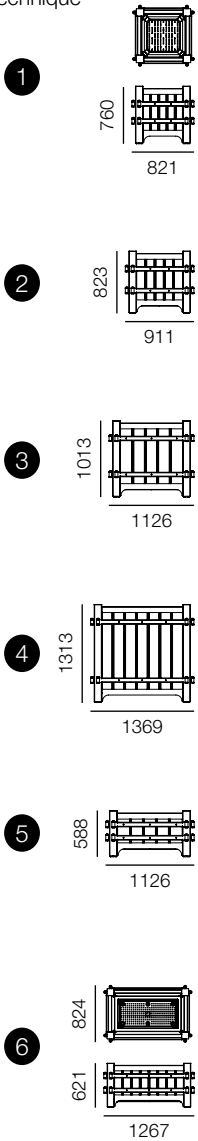

Les-Sables-d'Olonne (85)
 Panneaux bois avec application peinture - **Option boule décorative**
 Exotic wood panels with paint - **Decorative ball option**



Structure : Acier peint, pieds réglables
| Panneaux : Aluminium peint | **Bac de culture :** Bac de culture noir en plastique recyclé p. 32 | **Options :** Finition tête de poteau boule forgée (A), boule décorative (B) ou ogive (C), Système de levage pour bac de culture p. 32

Structure : Hot lacquered steel, adjustable feet | Panels : Lacquered aluminium | Planting liner : Planting liner colour black in recycled plastic p. 32 | Options : Finishing piece for posts forged ball (A), decorative ball (B) or ogive (C), Lifting system for planting liner p. 32

Classique



Bourbon-Lancy (71)
Option boule décorative
 Decorative ball option



technique
Fiche

DUALIS

Structure : Acier peint, pieds réglables | **Panneaux :** Bois exotique 3 lasures au choix p. 113, Bois stratifié lisse ou rainuré 4 coloris au choix p. 113, Acier peint tôle lisse ou pliée ou Émail | **Bac de culture :** Bac de culture noir en plastique recyclé p. 50 | **Options :** Finition tête de poteau boule forgée (A), boule décorative (B) ou ogive (C), Système de levage pour bac de culture p. 32

Structure : Hot lacquered steel, adjustable feet | **Panels :** Exotic wood 3 stains at your choice p. 113, Laminated wood smooth or grooved 4 colors at your choice p. 113, Steel sheet smooth or bended or Enamel | **Planting liner :** Planting liner colour black in recycled plastic p. 50 | **Options :** Finishing piece for posts forged ball (A), decorative ball (B) or ogive (C), Lifting system for planting liner p. 32



Boulogne-Billancourt (92)

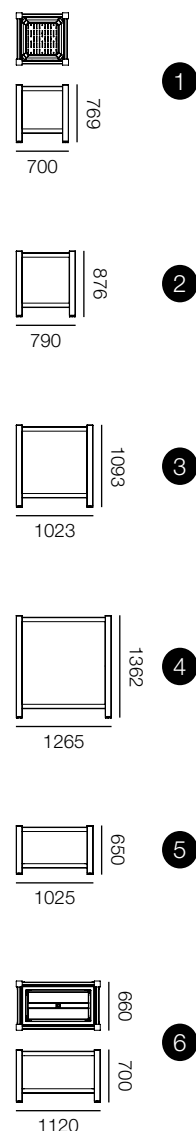

Finition tête de poteaux
Finishing piece for posts

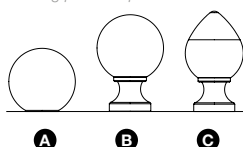



Fiche

technique

Asyma

Structure : Acier peint, pieds réglables | **Panneaux :** Bois stratifié lisse ou rainuré 4 coloris au choix p. 113 | **Bac de culture :** Bac de culture noir en plastique recyclé p. 32 | **Option :** Système de levage pour bac de culture p. 32

Structure : Hot lacquered steel, adjustable feet | **Panels :** Laminated wood smooth or grooved 4 colors at your choice p. 113 | **Planting liner :** Planting liner colour black in recycled plastic p. 32 | **Option :** Lifting system for planting liner p. 32

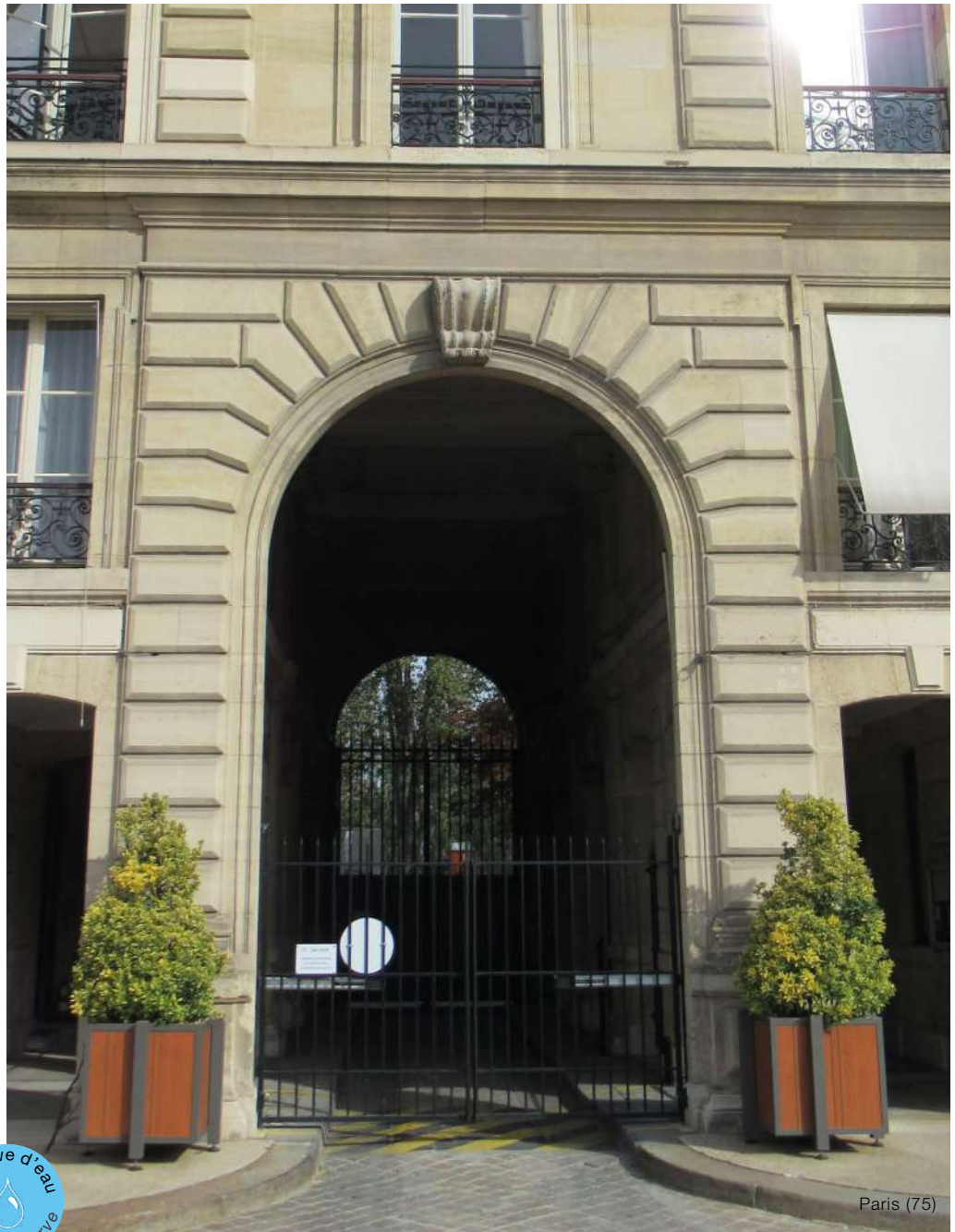
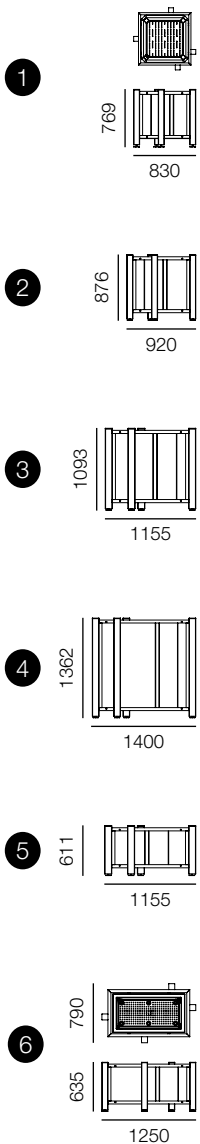



Recquignies (59)

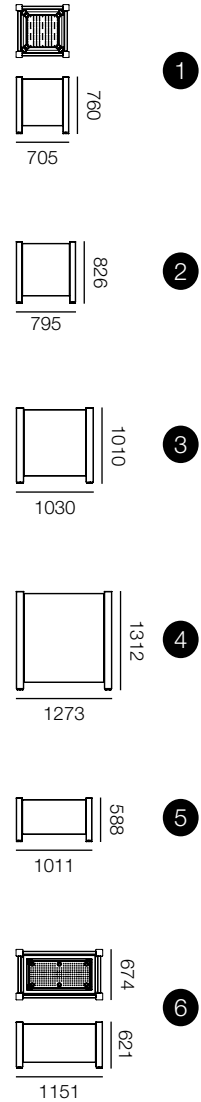

Recquignies (59)

Structure : Acier peint, pieds réglables
| Panneaux : Acier peint tôle lisse avec découpe « feuillage » sur deux faces
| Bac de culture : Bac de culture noir en plastique recyclé p. 32
| Options : Contre-tôle de contraste, Système de levage pour bac de culture p. 32

Structure : Hot lacquered steel, adjustable feet
| Panels : Steel sheet smooth with « leaf » laser cut on two faces
| Planting liner : Planting liner colour black in recycled plastic p. 32
| Options : Second steel sheet for the contrast, Lifting system for planting liner p. 32

Aéris





Fiche

technique

Pyrou

Bac : Acier peint, pieds réglables | **Bac de culture :** Bac de culture noir en plastique recyclé p. 32 | **Options :** Manutention par transpalette (ajout de cache-pieds), Système de levage pour bac de culture p. 32-33

Planter : Hot lacquered steel, adjustable feet | **Planting liner :** Planting liner colour black in recycled plastic p. 32 | **Options :** Moveable by pallet jack (addition of grooming), Lifting system for planting liner p. 32-33

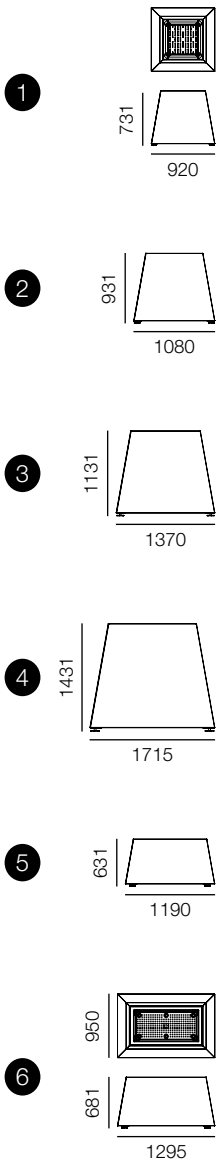

Vimoutiers (61)
Option manutention par transpalette
Option levage par palette



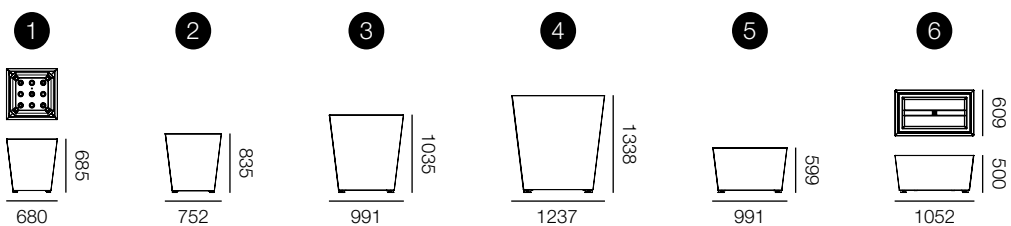

Bac : Acier peint, pieds réglables | **Bac de culture** : Bac de culture noir en plastique recyclé p. 32 | **Options** : Manutention par transpalette (ajout de cache-pieds), Système de levage pour bac de culture p. 32-33

Planter : Hot lacquered steel, adjustable feet | **Planting liner** : Planting liner colour black in recycled plastic p. 32 | **Options** : Moveable by pallet jack (addition of grooming), Lifting system for planting liner p. 32-33

HEDERA



technique

Fiche



Kesa

Structure : Acier peint, pieds réglables | **Panneaux :** Bois stratifié lisse ou rainuré 4 coloris au choix p. 113, Acier peint tôle lisse | **Bac de culture :** Bac de culture noir en plastique recyclé p. 32 | **Option :** Système de levage pour bac de culture p. 32

Structure : Hot lacquered steel, adjustable feet | **Panels :** Laminated wood smooth or grooved 4 colors at your choice p. 113, Steel sheet smooth | **Planting liner :** Planting liner colour black in recycled plastic p. 32 | **Option :** Lifting system for planting liner p. 32

1

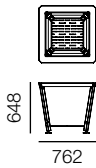

2

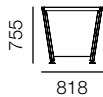

3

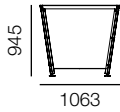

4

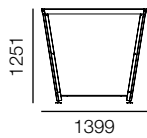

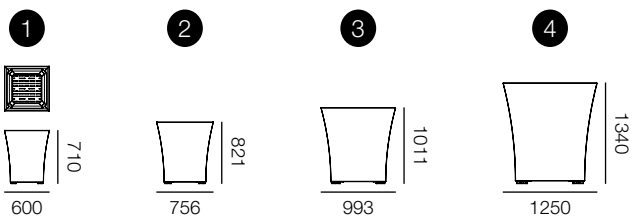

Plaisance-du-Touch (31)



Confolens (16)
Option manutention par transpalette
Option Moveable by pallet jack

Bac : Acier peint, pieds réglables | **Bac de culture** : Bac de culture noir en plastique recyclé p. 32 | **Option** : Manutention par transpalette (ajout de cache-pieds), Système de levage pour bac de culture p. 32-33

Planter : Hot lacquered steel, adjustable feet | **Planting liner** : Planting liner colour black in recycled plastic p. 32 | **Option** : Moveable by pallet jack (addition of grooming), Lifting system for planting liner p. 32-33

Concave



technique

Fiche



Fiche

technique

Cléo

Bac : Acier peint, pieds réglables | **Bac de culture :** Bac de culture noir en plastique recyclé p. 32 | **Option :** Système de levage pour bac de culture p. 32

Planter : Hot lacquered steel, adjustable feet | **Planting liner :** Planting liner colour black in recycled plastic p. 32 | **Option :** Lifting system for planting liner p. 32

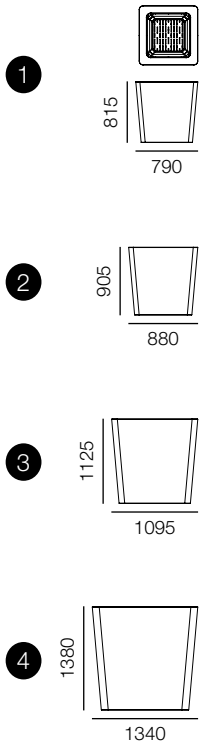

Paris (75)





Puteaux (92)
Option éclairage LED
 Option LED lighting

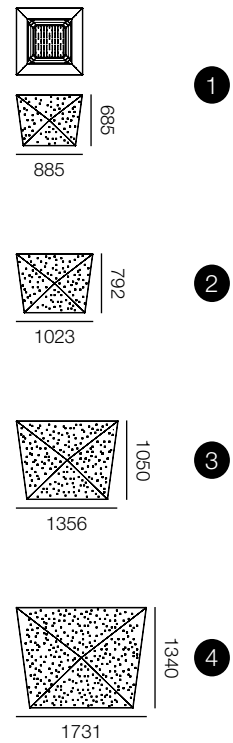

Champfleury (51)

Bac : Aluminium peint | **Bac de culture :** Bac de culture noir en plastique recyclé p. 32 | **Options :** Système de levage pour bac de culture p. 32, Éclairage LED

Planter : Hot lacquered aluminium | *Planting liner :* Planting liner colour black in recycled plastic p. 32 | **Options :** Lifting system for planting liner p. 32, LED lighting

Mosaïque by



BAC DE FLEURISSEMENT
PLANTER

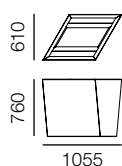

JARDINIÈRE
FLOWERBOX

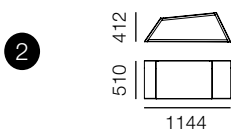
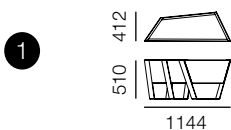

Bac et jardinière : Acier peint | **Option :** sans fond (bac)

Planter and flowerbox : Hot lacquered steel | **Option :** Without bottom (planter)

C-NATURA





technique

Fiche

Atempo

Bac : Acier peint, pieds réglables | **Bac de culture :** Bac de culture noir en plastique recyclé p. 32 | **Options :** Manutention par transpalette (ajout de cache-pieds), Système de levage pour bac de culture p. 32-33

Planter : Hot lacquered steel, adjustable feet | **Planting liner :** Planting liner colour black in recycled plastic p. 32 | **Options :** Moveable by pallet jack (addition of grooming) Lifting system for planting liner p. 32-33



Option anneaux de levage
Lifting hooks option

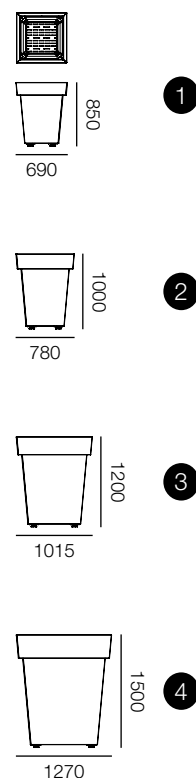



Fiche

technique

Eole

Bac : Acier peint, pieds réglables | **Bac de culture :** Bac de culture noir en plastique recyclé p. 32
Options : Manutention par transpalette (ajout de cache-pieds), Système de levage pour bac de culture p. 32-33

Planter : Hot lacquered steel, adjustable feet | **Planting liner :** Planting liner colour black in recycled plastic p. 32 | **Options :** Moveable by pallet jack (addition of grooming), Lifting system for planting liner p. 32-33

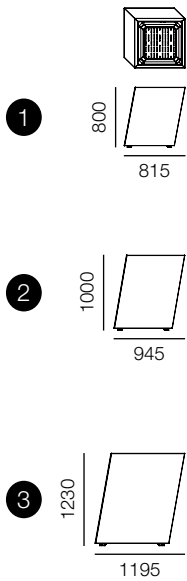

St-Yrieix-sur-Charente (16)
Acier corten sablé et activé
Sanded and activated Corten steel





Tournai (Belgique)
 Acier corten sablé, activé et stabilisé naturellement - **Option pieds réglables**
 Sanded, activated and naturally stabilized Corten steel - **Option adjustable feet**

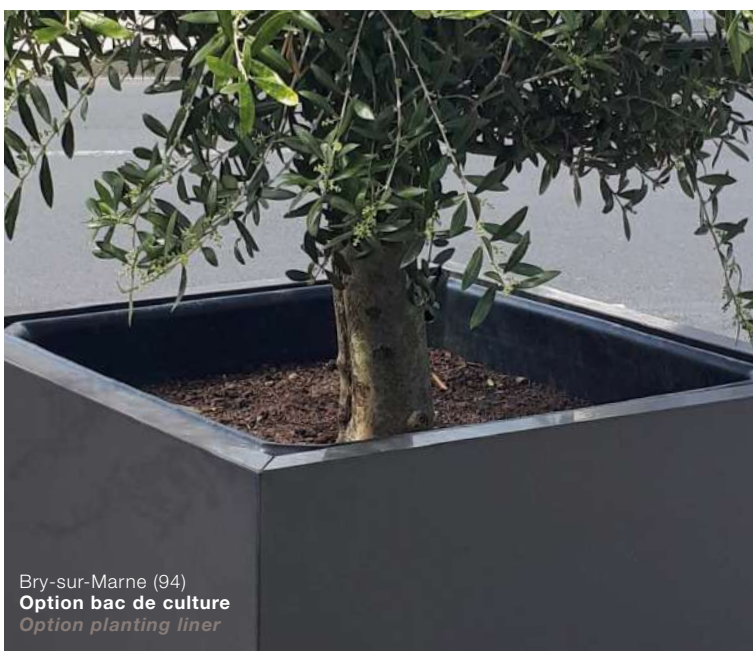
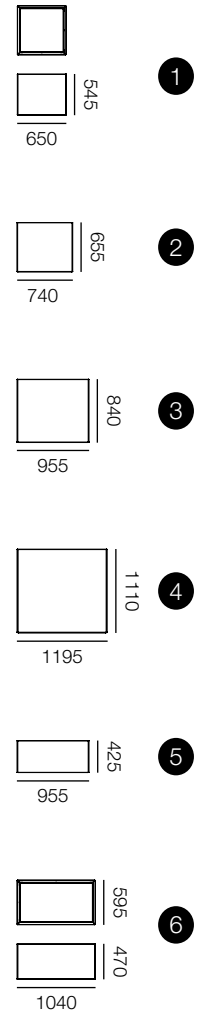

Bry-sur-Marne (94)
Option bac de culture
 Option planting liner

Bac : Acier peint | **Options :** Pieds réglables, Bac de culture noir en plastique recyclé p. 32, Manutention par transpalette (ajout de cache-pieds), Système de levage pour bac de culture p. 32-33

Planter : Hot lacquered steel | **Options :** Adjustable feet, Planting liner colour black in recycled plastic p. 32, Moveable by pallet jack (addition of grooming), Lifting system for planting liner p. 32-33

SYNERGIE



Fiche



Fiche

technique

Octogone

Bac : Acier peint | **Bac de culture :** Vase noir en plastique recyclé p. 32 sauf n°1 | **Options :** Pieds réglables, Système transpaletttable (pieds réglables avec cache-pieds), Système de levage pour bac de culture p. 32-33

Planter : Hot lacquered steel | **Planting liner :** Vase colour black in recycled plastic p. 32 except for nr 1 | **Options :** Adjustable feet, moveable by pallet jack (adjustable feet and grooming), Lifting system for planting liner p. 32-33

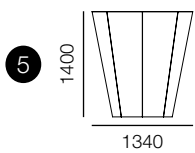
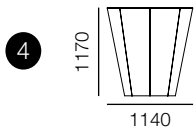
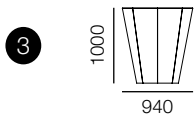
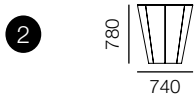

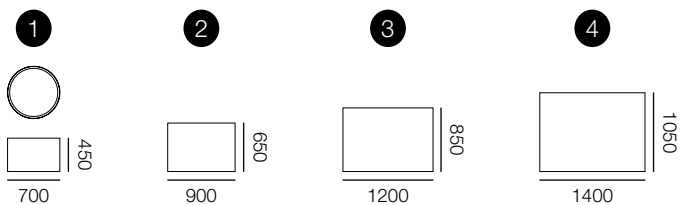

Bac : Acier peint | **Options** : Pieds réglables, Système transpaletttable (pieds réglables avec cache-pieds) p. 33, bac de culture aluminium, réserve d'eau

Planter : Hot lacquered steel | **Options** : Adjustable feet, moveable by pallet jack (adjustable feet with grooming) p. 33, aluminium planting liner, water reserve

Patine



technique

Fiche

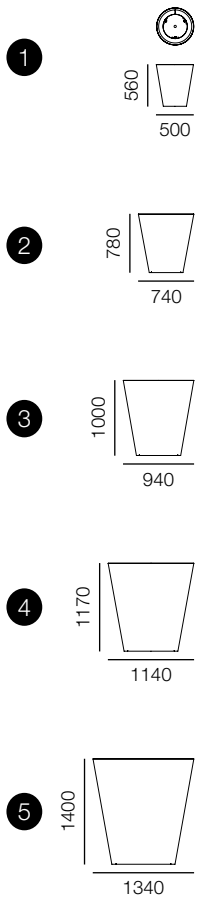

Plaisir (78)



Bac : Acier peint | **Bac de culture** : Vase noir en plastique recyclé p. 32 sauf n°1 | **Options** : Pieds réglables, Système transpalette (pieds réglables avec cache-pieds), Système de levage pour bac de culture p. 32-33

Planter : Hot lacquered steel | **Planting liner** : Vase colour black in recycled plastic p. 32 except for nr 1 | **Options** : Adjustable feet, moveable by pallet jack (adjustable feet with grooming), Lifting system for planting liner p. 32-33

Perga



Fiche

technique



Montlouis-sur-Loire (37)

Option manutention par transpalette
Option Moveable by pallet jack



technique
Fiche

Extrabac

Bac : Acier peint | **Bac de culture** : Extravase noir en plastique recyclé p. 32 | **Options** : Pieds réglables, Système transpaletttable (pieds réglables avec cache-pieds), Système de levage pour bac de culture p. 33

Planter : Hot lacquered steel | **Planting liner** : Extravase colour black in recycled plastic p. 32 | **Options** : Adjustable feet, moveable by pallet jack (adjustable feet with grooming), Lifting system for planting liner p. 33



Lille (59)

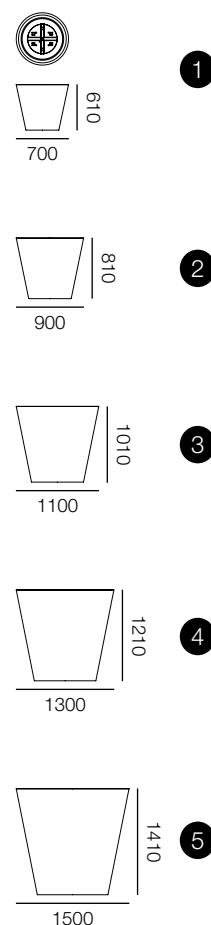



Fiche

technique

A-LINÉA

Bac : Acier peint | **Bac de culture :** Extravase p. 47
| Options : Pieds réglables, Système transpaletttable (pieds réglables avec cache-pieds), Système de levage pour bac de culture p. 33

Planter : Hot lacquered steel | **Planting liner :** Extravase p. 47 | **Options :** Adjustable feet, moveable by pallet jack (adjustable feet with grooming), Lifting system for planting liner p. 33

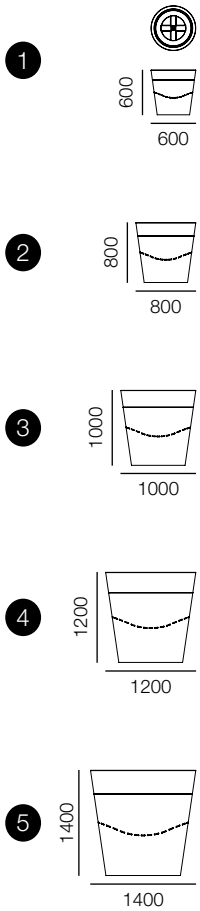

La Madeleine (59)

Option pieds réglables et système transpaletttable
Option adjustable feet and moveable by pallet jack





Ste Marie-de-Ré (17)

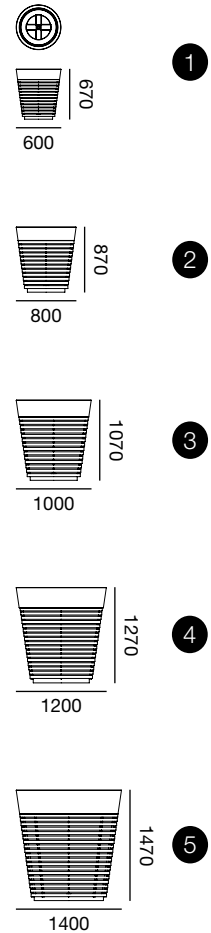

Bac : Acier peint, coloris p. 113 | **Bac de culture :** Extravase p. 47 | **Options :** Pieds réglables, Système transpalette (pieds réglables avec cache-pieds), Système de levage pour bac de culture p. 33

Planter : Hot lacquered steel, color chart p. 113 | **Planting liner :** Extravase p. 47 | **Options :** Adjustable feet, moveable by pallet jack (adjustable feet with grooming), Lifting system for planting liner p. 33



Pollestre (66)
Option pieds réglables - Coloris spécifiques
Option adjustable feet - Specific colours

PASTEL



technique
 Fiche

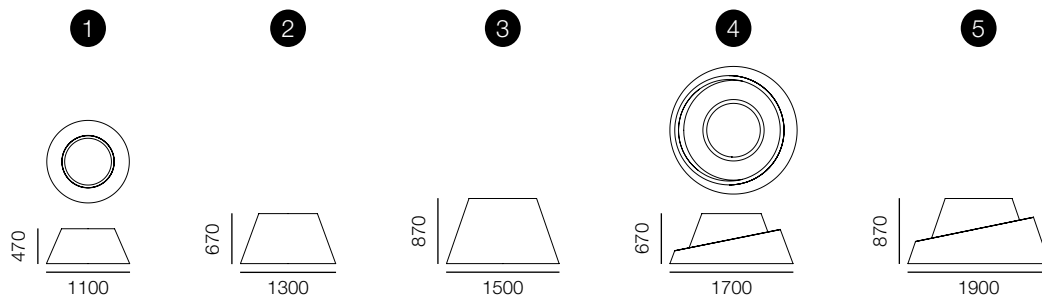

Barcelone (Espagne)

Bac : Acier peint | **Options (seulement pour les n°1, 2 et 3)** : Pieds réglables, Système transpaletttable (pieds réglables avec cache-pieds) p. 33, réserve d'eau

Planter : Hot lacquered steel | **Options (only for nr 1, 2 and 3)** : Adjustable feet, moveable by pallet jack (adjustable feet with grooming) p. 33, water reserve

Contrario



St-Genis-Pouilly (01)



Fiche

technique



SQUARE

Bac : Acier peint | **Option :** réserve d'eau

Planter : Hot lacquered steel | **Option :** Water reserve



1/2 BOULE
1/2 PLANTER



1

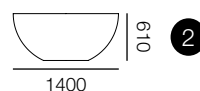
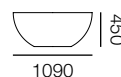

2

BOULE
PLANTER



3

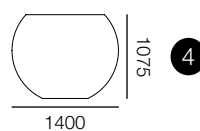
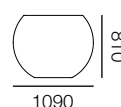

4

BOULE BISEAUTÉÉ
BEVELLED EDGE PLANTER



5

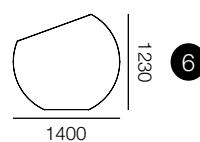
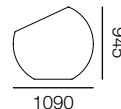

6

DÉTAILS DES OPTIONS BAC DE FLEURISSEMENT

DETAILS OF PLANTER OPTIONS

BAC DE CULTURE NOIR EN PLASTIQUE RECYCLÉ

PLANTING LINER COLOUR BLACK
IN RECYCLED PLASTIC

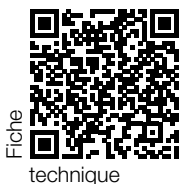

SYSTÈME DE LEVAGE

LIFTING SYSTEM



1 2 3 5

ANNEAUX DE LEVAGE
LIFTING HOOKS



4

STRUCTURE D'ÉLINGAGE AVEC
ANNEAUX DE LEVAGE
LIFTING STRUCTURE WITH HOOKS

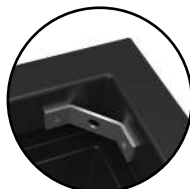

6

PATTES DE LEVAGE
LIFTING LEGS

BAC DE CULTURE VASE NOIR EN PLASTIQUE RECYCLÉ

VASE PLANTING LINER COLOUR BLACK
IN RECYCLED PLASTIC



1 2 3

PATTES DE LEVAGE
LIFTING LEGS



4

STRUCTURE D'ÉLINGAGE AVEC
PATTES DE LEVAGE
LIFTING STRUCTURE WITH LEGS

**BAC DE CULTURE
EXTRAVASE NOIR EN PLASTIQUE RECYCLÉ**

EXTRAVASE PLANTING LINER COLOUR BLACK
IN RECYCLED PLASTIC



2 3 4

PATTES DE LEVAGE
LIFTING LEGS



5 6

STRUCTURE DE RENFORT
AVEC PATTES DE LEVAGE
LIFTING STRUCTURE WITH LEGS

ÉLÉVATION DU BAC

PLANTER LIFTING SOLUTION



PIEDS RÉGLABLES

ADJUSTABLE FEET

pour les bacs **non munis** de pieds réglables

for planters which are not with adjustable feet as standard

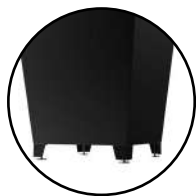

MANUTENTION PAR TRANSPALETTE

MOVEABLE BY PALLET JACK

pour les bacs **déjà munis** de pieds réglables

for planters which are with adjustable feet as standard



SYSTÈME TRANSPALETTE

ADJUSTABLE FEET AND MOVEABLE BY PALLET JACK

pour les bacs **non munis** de pieds réglables

for planters which are not with adjustable feet as standard

1- Paris (75) | Zinc pré-patiné (acier galvanisé et panneaux zinc) | Bac sans fond panneaué sur mesure - *Pre-patined zinc (galvanized steel and zinc panels)* | *Specific planter without bottom* · 2- Roanne (42) | **Acier corten sablé et activé** | Bac sans fond panneaué sur mesure - *Sanded and activated corten steel* | *Specific planter without bottom* · 3- Paris (75) | **Acier inoxydable brossé** | Bac avec fond panneaué sur mesure - *Brushed stainless steel* | *Specific planter with assembled basis* · 4- Cenon (33) | **Acier thermolaqué brillant** | Bac sans fond panneaué sur mesure - *Bright hot lacquered steel* | *Specific planter without bottom* · 5- Douai (59) | **Acier corten sablé, activé et stabilisé** | Bac avec fond soudé sur mesure - *Sanded, activated and stabilized corten steel* | *Specific welded planter* · 6- Saalfelden (AUTRICHE) | **Acier thermolaqué brillant** | Bac avec fond soudé sur mesure - *Bright hot lacquered steel* | *Specific welded planter*



BACS POUR AMÉNAGER LE PAYSAGE

PLANTERS FOR LANDSCAPING

BAC SANS FOND PANNEAUTÉ

PLANTER WITHOUT BOTTOM

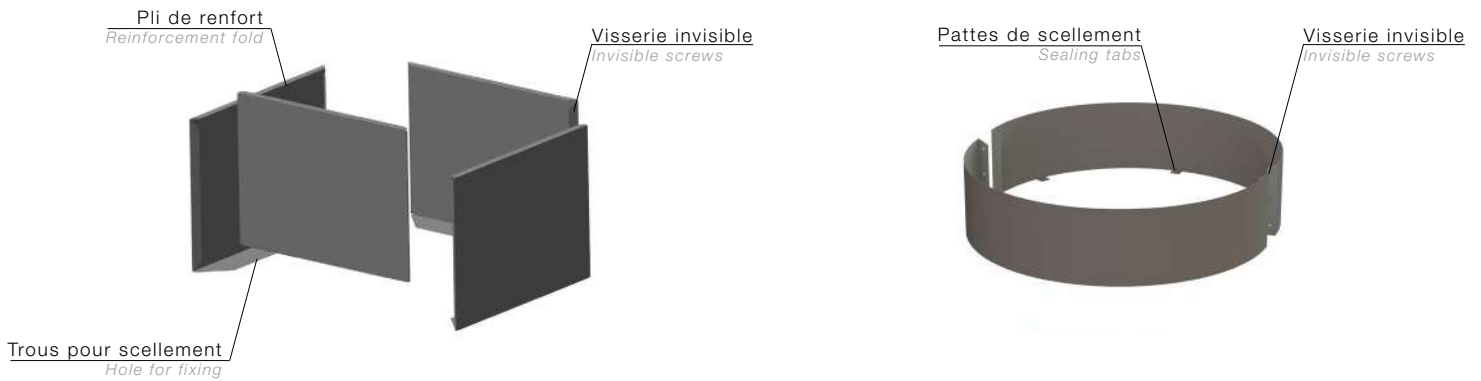

BAC AVEC FOND PANNEAUTÉ

PLANTER WITH ASSEMBLED BASIS

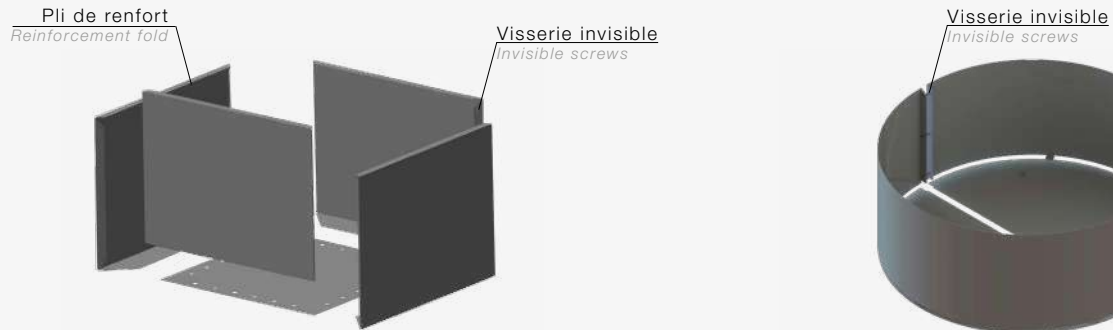

BAC AVEC FOND SOUDÉ

PLANTER WITH WELDED BASIS



d'informations

Plus

LA GESTION DE L'EAU

WATER MANAGEMENT

EN PARTENARIAT AVEC LA STARTUP VERTUO NOUS INNOVONS EN MATIÈRE DE GESTION DE L'EAU. NOUS VOUS PROPOSONS UNE SOLUTION DE VÉGÉTALISATION PAR RÉCUPÉRATEUR DES EAUX PLUVIALES POUR LUTTER CONTRE LES INSTABILITÉS PLUVIOMÉTRIQUES ET LES ÎLOTS DE CHALEUR, LE TOUT EN TOUTE AUTONOMIE.
IN PARTNERSHIP WITH THE STARTUP VERTUO WE INNOVATE IN WATER MANAGEMENT, WE OFFER A SOLUTION OF VEGETATION BY RAINWATER RECOVERY TO FIGHT AGAINST RAINFALL INSTABILITIES AND HEAT ISLANDS, ALL IN COMPLETE AUTONOMY.

AMÉNAGEMENT AVEC L'ABRI VÉLOS-VOYAGEURS BE'MAX

LAYOUT WITH THE BE'MAX BICYCLE AND PASSENGER SHELTER



Structure : Aluminium peint, dimensions 2500 x 1500 x 2405 mm | **Bac :** Aluminium peint, dimensions 1500 x 450 x 600 mm | **Option :** Fourniture substrat et végétaux

Structure : Hot lacquered aluminium, dimensions 2500 x 1500 x 2405 mm | **Planter :** Hot lacquered aluminium, dimensions 1500 x 450 x 600 mm | **Option :** Supply of substrate and plants

VOUS ÊTES INTÉRESSÉ(E) PAR CETTE INNOVATION QUI CAPTE LES EAUX DE PLUIE ?

ARE YOU INTERESTED IN THIS INNOVATION THAT CAPTURES RAINWATER?

1. Prise en compte de votre besoin d'autonomie
2. Etude pluviale en fonction de votre toiture
3. Conseils sur les végétaux à utiliser

1. Consideration of your need for autonomy
2. Rain study according to your roof
3. Advice on the plants to use



1- Aluminium thermolaqué grainé (sablé) | Bac avec assise en robinier saturé - Sanded (grooved) hot lacquered aluminium | Planter with stained black locust seat
 2- Aluminium thermolaqué grainé (sablé) | Bac avec assise en robinier saturé - Sanded (grooved) hot lacquered aluminium | Planter with stained black locust seat
 3- Aluminium thermolaqué grainé (sablé) | Bac avec assise en robinier saturé - Sanded (grooved) hot lacquered aluminium | Planter with stained black locust seat

INSPIRATIONS

INSPIRATIONS



1- Les-Essarts-en-Bocage (85) | **Acier thermolaqué brillant** | Bac sans fond panneauté sur mesure - *Bright hot lacquered steel* | *Specific planter without bottom* · 2- Meyrin (Suisse) | **Acier corten sablé (livré non activé)** | Bac avec fond panneauté sur mesure - *Sanded corten steel (delivered non activated)* | *Specific planter without bottom* · 3- Bossey (74) | **Acier thermolaqué brillant** | Bac de fleurissement DUALIS spécifique avec découpe laser - *Bright hot lacquered steel* | *DUALIS planter with laser cut*



4- Port-en-Bessin-Huppain (14) | **Acier thermolaqué grainé (sablé)** | Bac avec fond soudé sur mesure avec passage de fourches - *Sanded (grooved) hot lacquered steel* | Specific welded planter with forklift space • 5- Cosne-Cours-sur-Loire (58) | **Acier inoxydable brossé** | Bac avec fond panneaué sur mesure - *Brushed stainless steel* | Specific planter with assembled panels • 6- Paris (75) | **Zinc pré-patiné (acier galvanisé et panneaux zinc)** | Bac avec fond panneaué et table d'eau sur mesure, assise en robinier saturé - *Pre-patined zinc (galvanized steel and zinc panels)* | Specific water table and planter with assembled panels, seat in stained black locust



POTS DE FLEURS

FLOWER POTS

Nos pots de fleurs apportent couleur et végétal au sein de la cité. Ils aident à la renaturer. Chacun est doté d'une [réserve d'eau](#) afin de faciliter la gestion de cette ressource.

En plastique recyclable, ceux présentant des défauts sont broyés pour fournir 100% de la matière première de l'ensemble de nos bacs de culture.

Our flower pots bring color and greenery to the city. They help to renaturalize it. Each one is equipped with a [water reserve](#) in order to facilitate the management of this resource.

Made of recyclable plastic, those with defects are crushed to provide 100% of our culture tubs raw material.

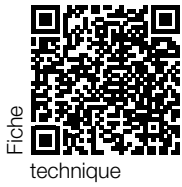

Fiche

technique

Gal'B

Pot de fleurs : Polyéthylène recyclable 17 coloris au choix p. 113 | **Options :** Système transpaletttable spécifique, platine anti-basculement, bac de culture noir en plastique recyclé p. 51, système de levage pour bac de culture p. 32

Flower pot : Recyclable polyethylene 17 colors at your choice p. 113 | **Options :** Specific support for pallet jack, fixing base plate, , planting liner colour black in recycled plastic p. 51, lifting system for planting liner p. 32

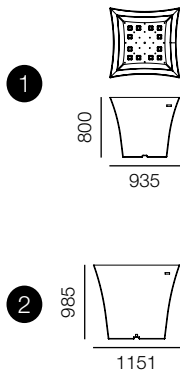

Les-Mathes-La-Palmyre (17)
Option platine anti-basculement
Option fixing base plate

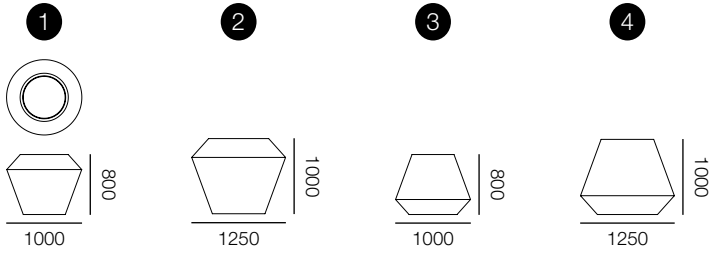

Maisons-Laffitte (78)



Rochefort (17)

Pot de fleurs : Polyéthylène recyclable 17 coloris au choix p. 113 | **Options :** Anneaux de levage, platine anti-basculement p. 51

Flower pot : Recyclable polyethylene 17 colors at your choice p. 113 | **Options :** Lifting hooks, fixing base plate p. 51

Saphir



technique

Fiche

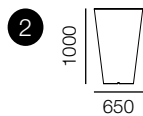
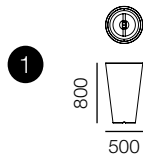

Monteynard (38)

Pot de fleurs : Polyéthylène recyclable 17 coloris au choix p. 113 | **Options** : Bac de culture noir en plastique recyclé, platine anti-basculement p. 51

Flower pot : Recyclable polyethylene 17 colors at your choice p. 113 | **Options** : Planting liner colour black in recycled plastic, fixing base plate, p. 51

Amphor



Option bac de culture
Option planting liner





Vase

Pot de fleurs : Polyéthylène recyclable 17 coloris au choix p. 113 | **Options** : Collier de levage, platine anti-basculement p. 51

Flower pot : Recyclable polyethylene 17 colors at your choice p. 113 | **Options** : Lifting collar, fixing base plate, p. 51



St-Pol-sur-Mer (59)

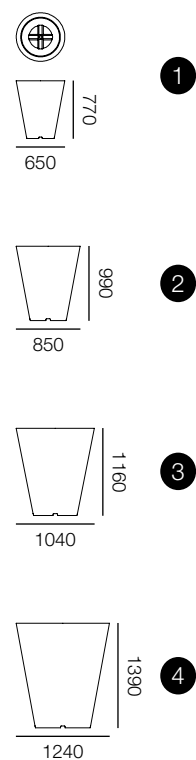



Fiche

technique

Extravase demi

Pot de fleurs : Polyéthylène recyclable 17 coloris au choix p. 113 | **Option :** Platine anti-basculement p. 51

Flower pot : Recyclable polyethylene 17 colors at your choice p. 113 | **Option :** Fixing base plate p. 51

1



2



3

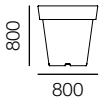

4

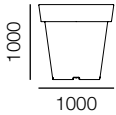

5

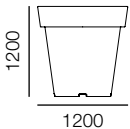

St-Aignan-sur-Cher (41)



Voiron (38)

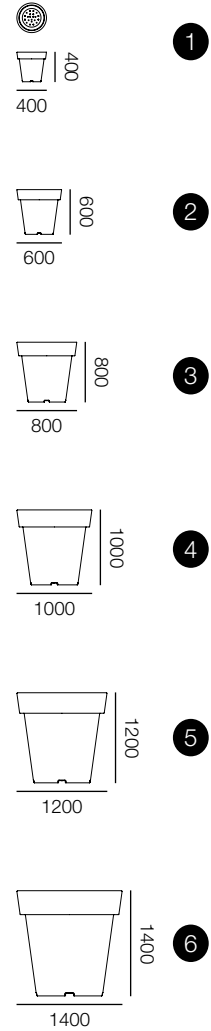

Pot de fleurs : Polyéthylène recyclable 17 coloris au choix p. 113 | **Options :** Collier de levage, platine anti-basculement p. 51

Flower pot : Recyclable polyethylene 17 colors at your choice p. 113 | **Options :** Lifting collar, fixing base plate, p. 51



Chateauguay (Canada)

Extravase



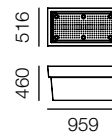

Mornant (69)
Option platine anti-basculement
Option fixing base plate



Pot de fleurs : Polyéthylène recyclable 17 coloris au choix p. 113 | **Options :** Pattes de levage, platine anti-basculement p. 51

Flower pot : Recyclable polyethylene 17 colors at your choice p. 113 | **Options :** Lifting hooks, fixing base plate p. 51

Rectiligne



Chemillé (49)



Fiche

technique



Pila

Pot de fleurs : Polyéthylène recyclable 17 coloris au choix p. 113 | **Option :** Platine anti-basculement p. 51

Flower pot : Recyclable polyethylene 17 colors at your choice p. 113 | **Option :** Fixing base plate p. 51

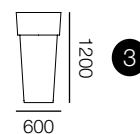
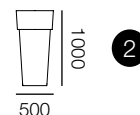
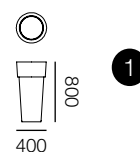



Quadri

Pot de fleurs : Polyéthylène recyclable 17 coloris au choix p. 113

Flower pot : Recyclable polyethylene 17 colors at your choice p. 113

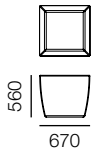

DÉTAILS DES OPTIONS POT DE FLEURS

DETAILS OF FLOWER POT OPTIONS



SYSTÈME
TRANSPALETTABLE
SPÉCIFIQUE
*SPECIFIC SUPPORT
FOR PALLET JACK*



ANNEAUX/PATTES
DE LEVAGE
LIFTING HOOKS



COLLIER DE LEVAGE
pour chariot élévateur
*LIFTING COLLAR
for lifting truck*



PLATINE
ANTI-BASCULEMENT
FIXING BASE PLATE



BAC DE CULTURE
PLANTING LINER





JARDINS URBAINS

URBAN GARDENS

Nos jardins urbains sont une solution idéale pour rafraîchir et dynamiser les zones urbaines artificialisées. Le temps d'une halte, les usagers apprécieront se retrouver au cœur de la végétation afin de profiter d'une zone d'ombre.

Il vous sera possible de personnaliser ces derniers avec une couleur, une découpe laser, une matière différente ou bien une [solution de gestion de l'eau](#). ATECH s'adapte à chaque besoin.

Our urban gardens are an ideal solution to refresh and energize artificial urban areas. During a stopover, users will appreciate taking a rest in the middle of green and shaped areas.

You will be able to customize these planters with a color, a laser cut, a different material or a [water management solution](#). ATECH adapts to each need.

MODULES

MODULES

1

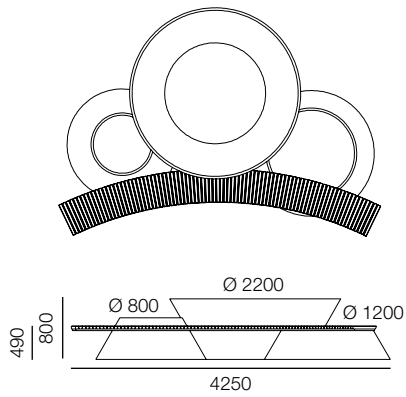

2

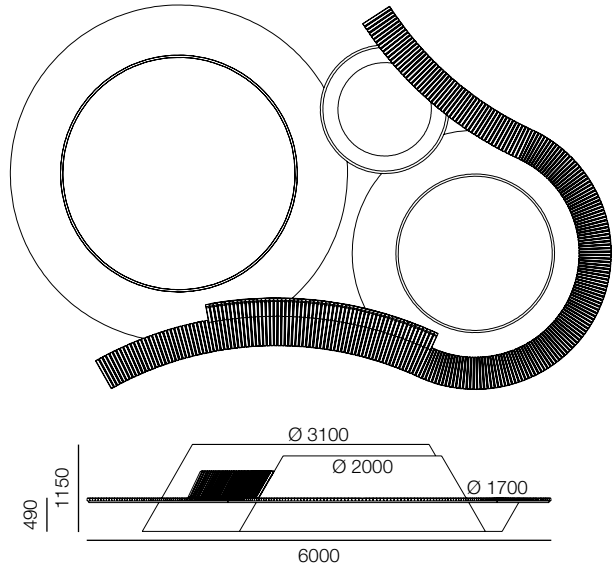

COMPOSEZ VOS AGENCEMENTS

SET YOUR LAYOUTS

(A) 1-1
8500 X 5000

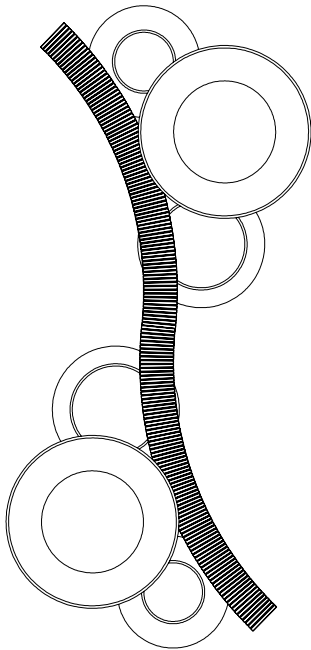

(B) 1-2
10000 X 6000

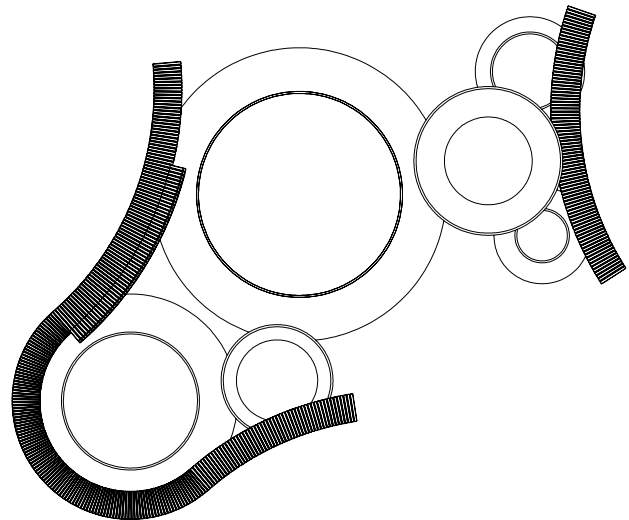



Villedieu-les-Poêles (50)
Module 1
Module 1



technique

Fiche

Olympe

Structure : Acier peint | **Assise** : Lames bambou, bois exotique, robinier saturé ou chêne saturé p. 113 | **Options** : Version « light », tablette, corolle, brumisation

Planter : Hot lacquered steel | **Seat** : Slats in bamboo, exotic wood, stained robinia or stained oak p. 113 | **Options** : « Light » version, shelf, misting, corolle



Pleugriffet (56)
Module 1
Module 1



Fiche

technique

PRISME

Structure : Acier peint, système transpaletttable | **Assise et dossier** : Lames bambou, bois exotique, robinier saturé ou chêne saturé p. 113 | **Option** : Tablette

Structure : Hot lacquered steel, moveable with pallet jack | **Seat and back** : Slats in bamboo, exotic wood, stained robinia or stained oak p. 113 | **Option** : Shelf



Landerneau (29)
Module 3
Module 3



Tourcoing (59)
Module 5
Module 5

MODULES

MODULES

1 BAC
PLANTER

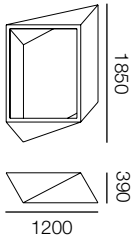

2 BANQUETTE
BACKLESS BENCH

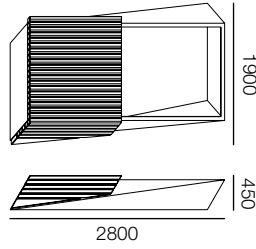

3 BANC
BENCH

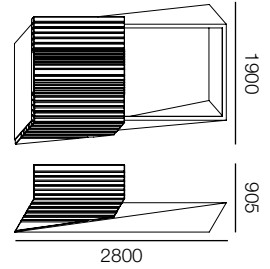

4 BANQUETTE
BACKLESS BENCH

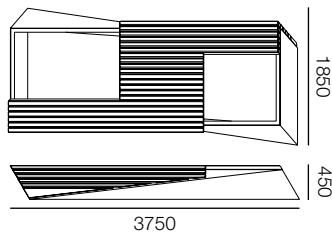

5 BANC
BENCH

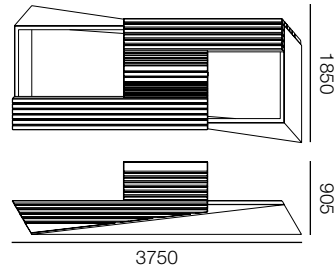

COMPOSEZ VOS AGENCEMENTS

SET YOUR LAYOUTS

A 1-5-1
5750 X 1850

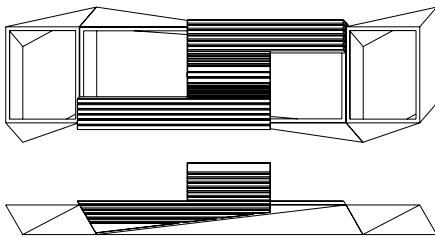

B 3-5
6350 X 1900

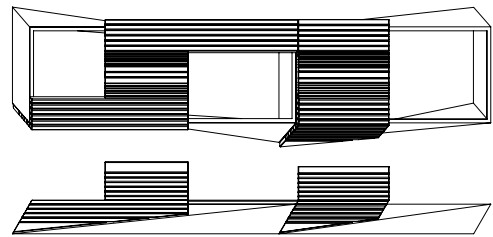

C 1-4-2
7350 x 1900

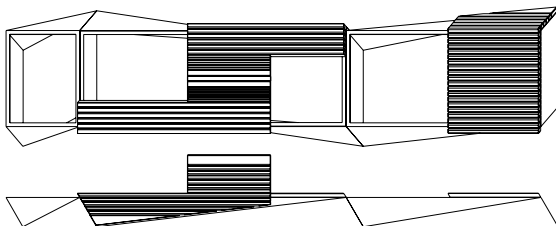

D 4-1-5
8400 X 1850

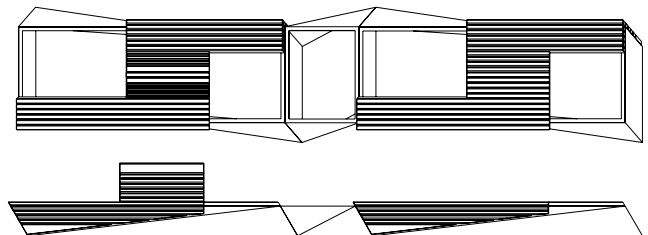

MODULES

MODULES

EXTRAVASE
Ø 800

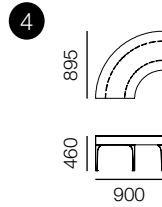
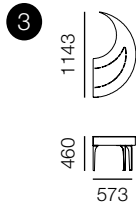
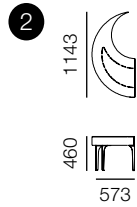
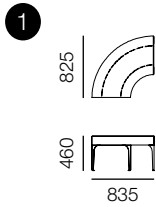

EXTRAVASE
Ø 1000

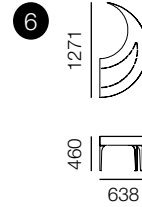
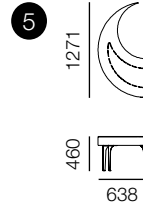

EXTRAVASE
Ø 1200

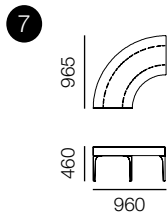
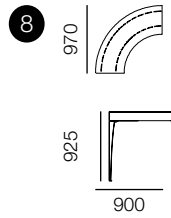

TABLE
TABLE



COMPOSEZ VOS AGENCEMENTS

SET YOUR LAYOUTS

A 2-3
1235 X 1150

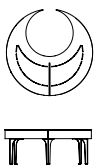

B 5-6
1400 X 1280

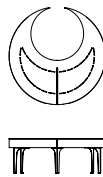

C 4-4-4-4
1800 X 1800

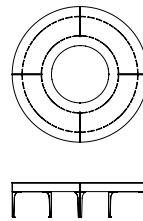

D 7-7-7-7
1930 X 1930

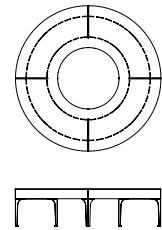

E 6-4-4-1-1-3
2950 X 1735

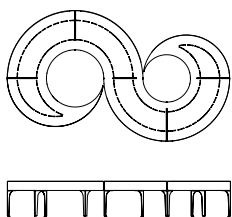

F 6-4-4-1-1-1-1-3
4100 X 2560

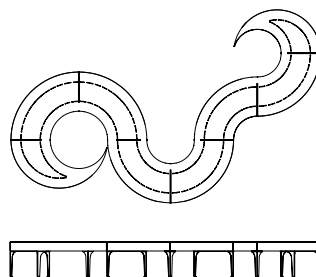

G 8-8-8-8
1800 X 1800

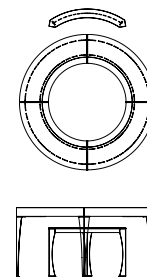



Montpon-Ménéstérol (24)
 Agencement C - **Option pot de fleurs Extravase**
 A layout - *Extravase flower pot option*



technique
 Fiche

A-LINÉA

Structure : Acier peint | **Option** : Pot de fleurs Extravase p. 47 ou bac de fleurissement Perga p. 26

Structure : Hot lacquered steel | **Option** : Extravase flower pot p. 47 or Perga planter p. 26



Le-Croisic (44)
 Agencement F - Agencement A - **Option pot de fleurs Extravase**
 F layout - A layout - *Extravase flower pot option*



Fiche

technique

Oasis

Structure : Acier peint, pieds réglables, système transpaletttable | **Assise :** Bois stratifié 4 coloris au choix p. 113 | **Bac de culture :** Aluminium | **Option :** Pattes de levage pour bac de culture

Structure : Hot lacquered steel, adjustable feet, movable by pallet jack | Seat : Laminated wood 4 colors at your choice p. 113 | Planting liner : Aluminium | Option : Lifting hooks for planting liner



Forges-les-Bains (91)
Modules 2 - 4 - 5 - 6 - 1 - 3
Modules 2 - 4 - 5 - 6 - 1 - 3



Trémontines (49)
Agencement A
A layout

MODULES PRODUCT

ASSISE SEAT

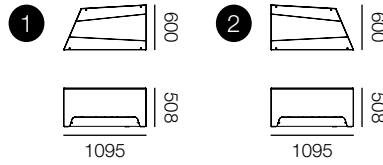

BAC PLANTER

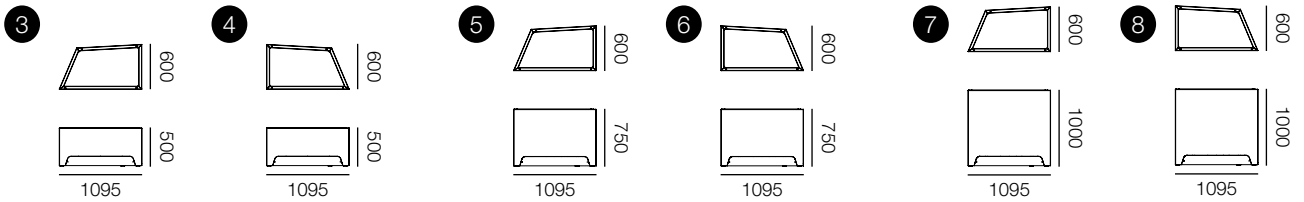

COMPOSEZ VOS AGENCEMENTS SET YOUR LAYOUTS

(A) 7-6-6-1
2187 X 1193

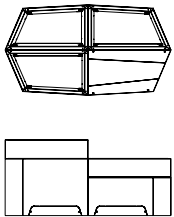

(B) 2-6-2-6-2
5023 X 638

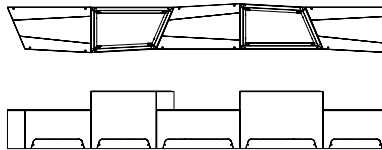

(C) 1-2-6-8-7-6-2-1
4153 X 1745

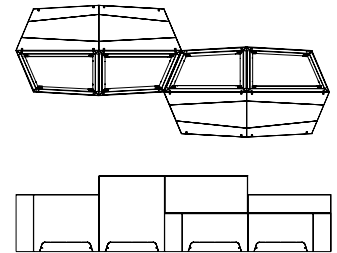

(D) 5-8-5-8-5-8-2-1-2-1-2-1
5734 X 2387

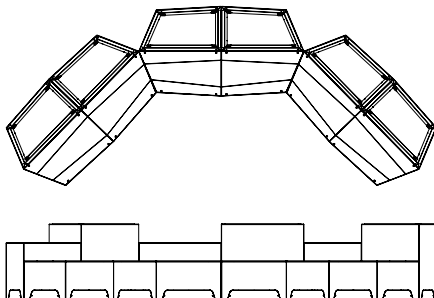

(E) 2-4-8-7-3-1-1-3-5-6-4-2
3498 X 2655

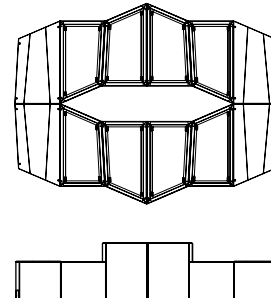

MODULES PRODUCTS

1 BANQUETTE SIMPLE
SINGLE BACKLESS BENCH

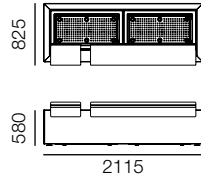

2 BANQUETTE DOUBLE
DOUBLE BACKLESS BENCH

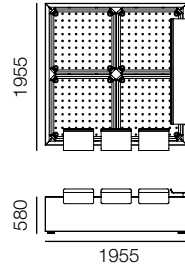

COMPOSEZ VOS AGENCEMENTS SET YOUR LAYOUTS

A 1-1
2117 X 1653

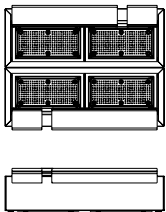

B 1-2-1
4128 X 2838

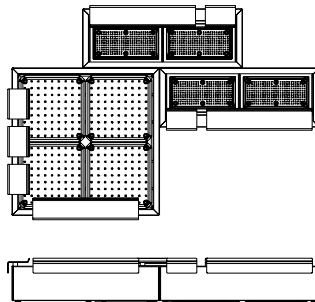

C 2-2
4023 X 2070

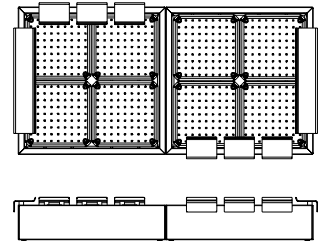

D 1-2-2-1
5200 X 4000

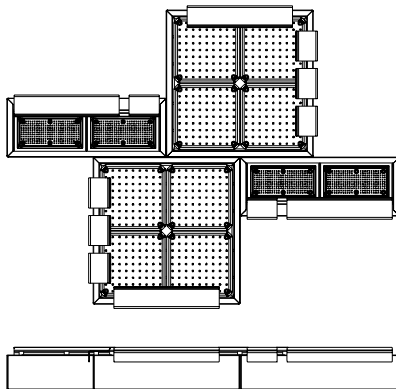

E 2-1-1-1-1-2
7300 X 4000

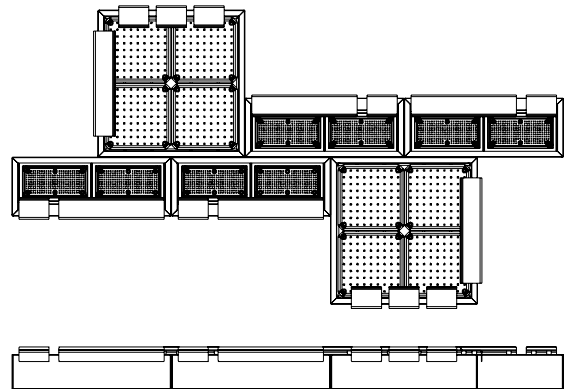



technique

Fiche



Module 1
Module 1

SQUARE

Structure : Acier peint, pieds réglables
| Bac de culture : Bac de culture noir n°5 ou n°6 en plastique recyclé p. 32
| Option : Pattes ou anneaux de levage pour bac de culture p. 32

Structure : Hot lacquered steel, adjustable feet
| Planting liner : Planting liner colour black nr 5 or nr 6 in recycled plastic p. 32
| Option : Lifting hooks for planting liner p. 32



Beuvrages (59)
Module 2
Module 2

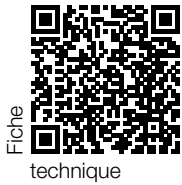

Fiche

technique

C-NATURA

Structure sans fond : Acier peint
| Assise et dossier : Lames bambou,
bois exotique, robinier saturé ou chêne
saturé p. 113

Structure without bottom : Hot lacquered
steel | **Seat and back :** Slats in bamboo,
exotic wood, stained robinia or stained oak
p. 113



Dammartin-les-Lys (77)

Module 2 - Acier corten sable, activé et stabilisé naturellement
Module 2 - Sanded, activated and naturally stabilized corten steel



Pornichet (44)

Module 4 - Acier corten sablé, activé et stabilisé naturellement
Module 4 - Sanded, activated and naturally stabilized corten steel

MODULES PRODUCT

MODULES OVALES OVAL MODULES

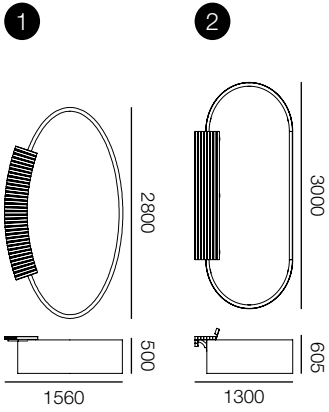

MODULES RONDS ROUND MODULES

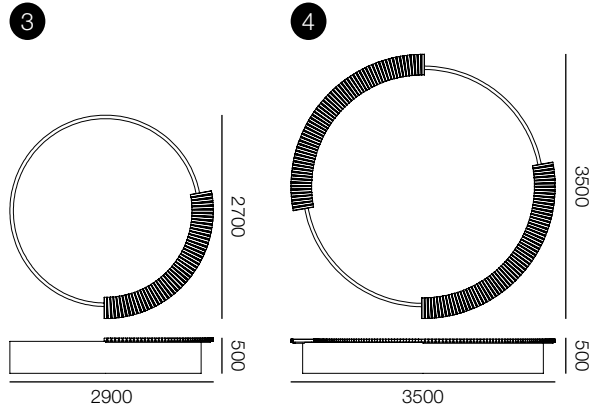

MODULES CARRÉS SQUARE MODULES

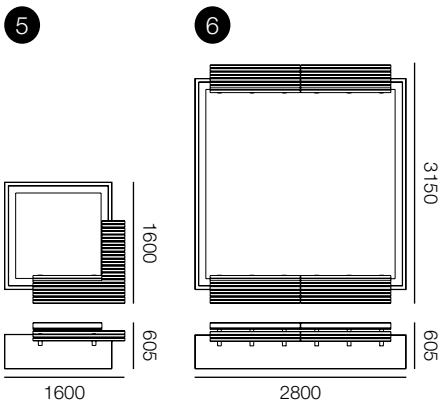

MODULES RECTANGULAIRES RECTANGULAR MODULES

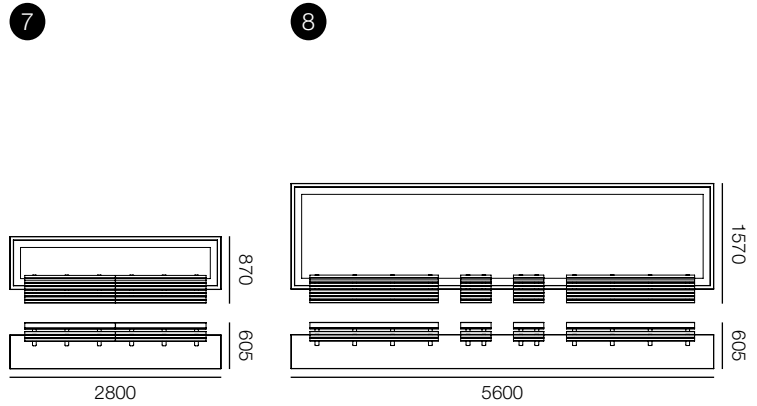

COMPOSEZ VOS AGENCEMENTS SET YOUR LAYOUTS

(A) 5-5-7
3200 X 2470

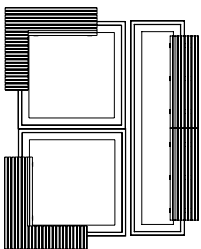

(B) 7-5-5-7
4400 X 4400

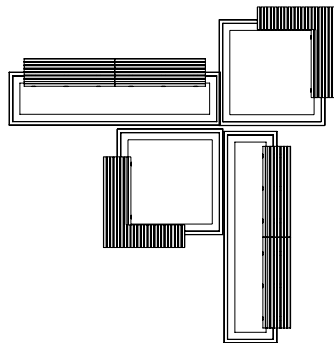

(C) 5-7-5-8
6000 X 3170

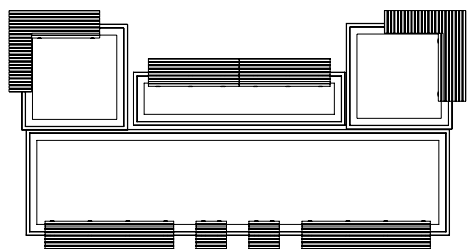

MODULES PRODUCTS

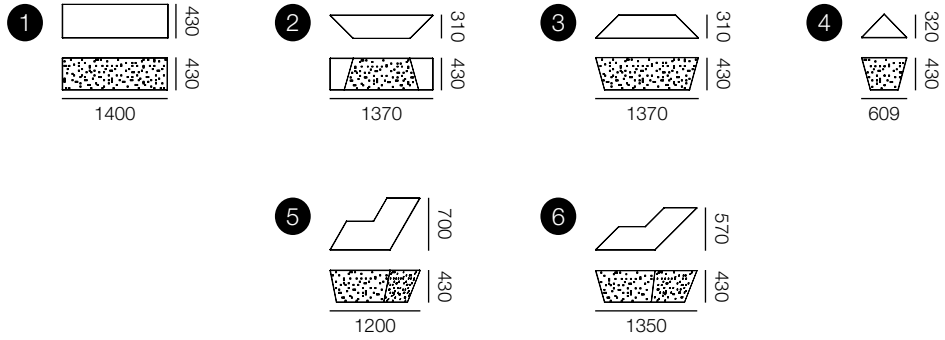

COMPOSEZ VOS AGENCEMENTS SET YOUR LAYOUTS

A 1-4-1-4-1-4-1-4
2280 X 2280

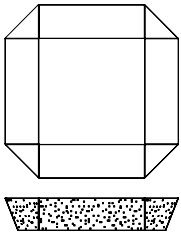

B 5-1-5-1-5-1
2810 X 2790

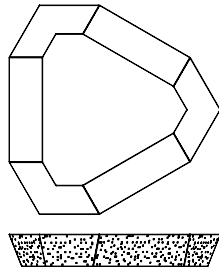

C 3-1-4-1-3-1-4-1
3360 X 2600

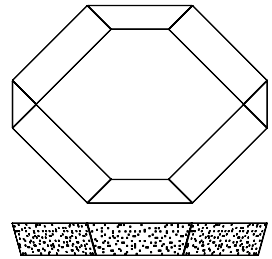

D 6-2-6-1-6-2-6-1
3500 X 2530

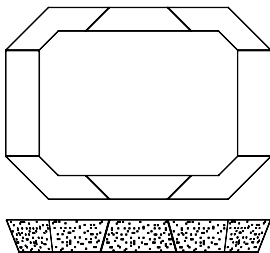

E 3-1-3-1-3-1-3-1
3370 X 3370

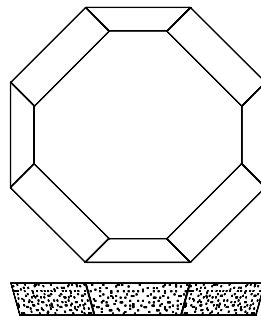



technique
Fiche



Champfleury (51)
Agencement B - **Option éclairage LED**
B layout - **Option LED lighting**

Mosaïque

Bac sans fond : Aluminium peint
| Option : Éclairage LED

Planter without bottom : Hot lacquered aluminium
| Option : LED lighting



Puteaux (92)
Autre agencement - **Option éclairage LED**
Other layout - **Option LED lighting**



Fiche

technique

FreshCity

Structure : Acier peint | **Assise et dossier** : Lames bois recyclé issu d'anciens châssis de fenêtres | **Option** : Pieds réglables

Structure : Hot lacquered steel | *Seat and back* : Slats in recycled wood from old window frames | *Option* : Adjustable feet



Paris (75)



Paris (75)
 Agencement A - **Option pieds réglables**
 A layout - **Option adjustable feet**

MODULES PRODUCT

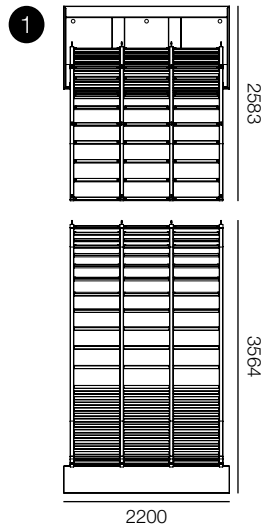

COMPOSEZ VOS AGENCEMENTS SET YOUR LAYOUTS

Ⓐ 1-1-1-1-1-1
8800 X 5200

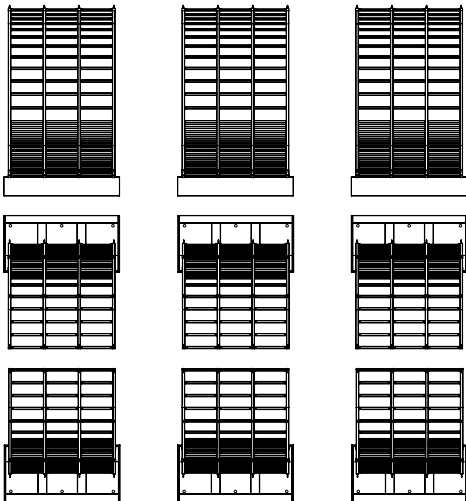

Ⓑ 1-1-1-1-1-1
8800 X 5200

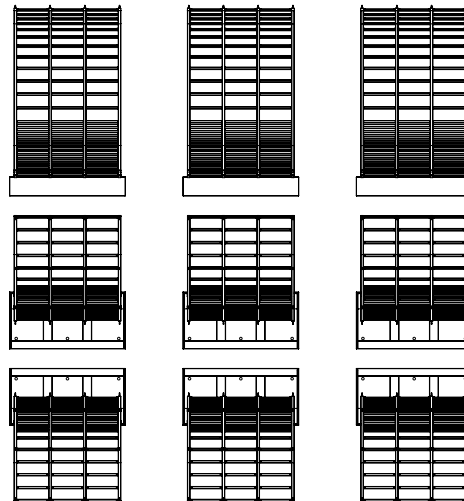

Ⓒ 1-1-1-1
7000 X 7000

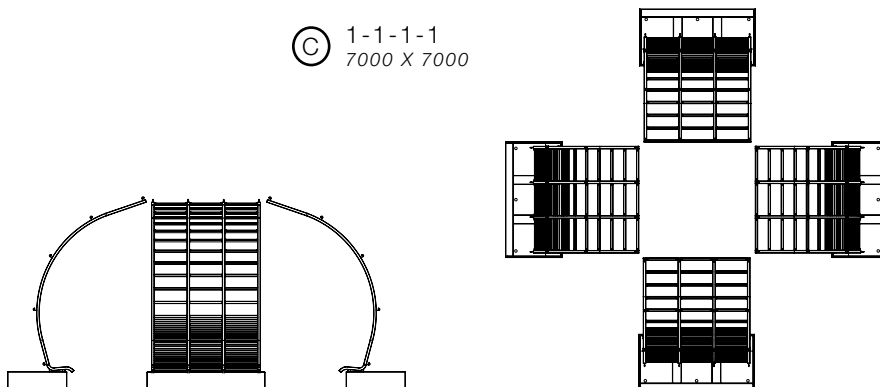

COMMENT RAFRAÎCHIR ET DYNAMISER ?

HOW TO REFRESH AND BRIGHT ?



1- Paris (75) | Aluminium thermolaqué grainé (sablé) | Costière sur mesure avec assise en bois exotique - Sanded (grooved) hot lacquered aluminium | Specific kerb with exotic wood slats · 2- Sanem (Luxembourg) | Acier corten sablé, activé et stabilisé | Costière sur mesure avec assise en bois exotique - Sanded, activated and stabilized corten steel | Specific kerb with exotic wood slats · 3- Bourg-en-Bresse (01) | Acier corten sablé (livré non activé) | Costière sur mesure, assise en bois exotique - Sanded corten steel (delivered non activated) | Specific kerb, slats in exotic wood

COSTIÈRES POUR AMÉNAGER LE PAYSAGE

KERBS FOR LANDSCAPING

COSTIÈRES option banquette

KERBS with backless bench option

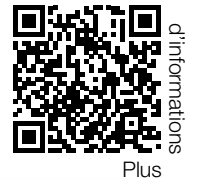
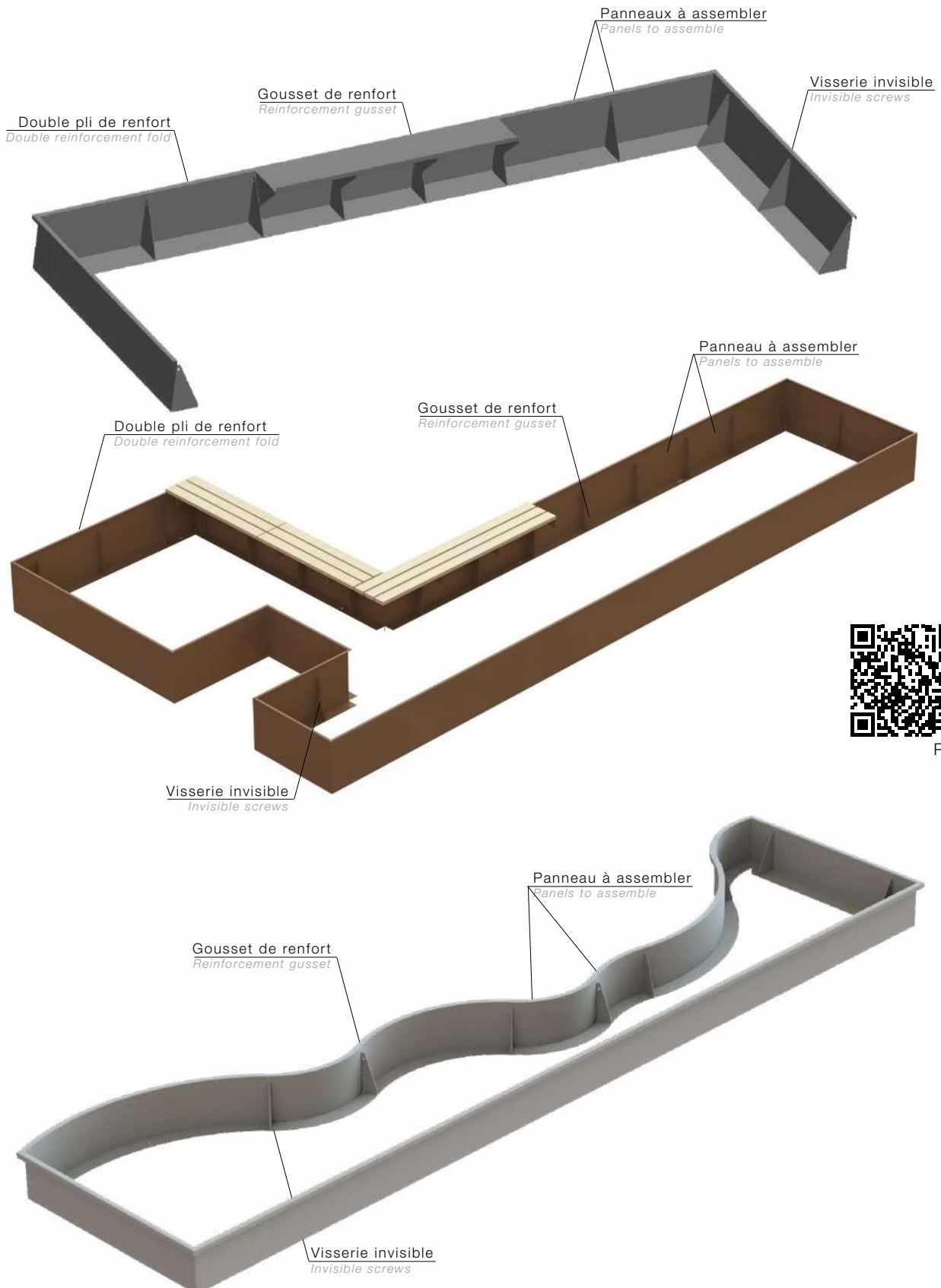

COMMENT VÉGÉTALISER ET CRÉER DES ZONES D'OMBRE ?

HOW VEGETALIZING AND CREATING SHADOW AREAS ?



1- Montmorillon (86) | **Acier thermolaqué brillant** | Jardin urbain sur mesure avec assise en bambou - *Bright hot lacquered steel* | *Specific urban garden with bamboo slats* • 2- Paris (75) | **Acier corten sablé, activé et stabilisé naturellement** | Jardin urbain sur mesure, assise fournie par le client - *Sanded, activated and naturally stabilized corten steel* | *Specific urban garden, slats provided by the client* • 3- Lisieux (14) | **Acier corten sablé (livré non activé)** | Bac sans fond avec assise en bois stratifié coloris spécifique - *Sanded corten steel (delivered non activated)* | *Planter without basis with seats in laminated wood (specific colour)*



4- Fessenheim (68) | **Acier corten sablé, activé et stabilisé naturellement** | Jardin urbain sur mesure avec assise en bois exotique - *Sanded, activated and naturally stabilized corten steel* | *Specific urban garden with exotic wood slats* • 5- Paris (75) | **Acier thermolaqué grainé (sablé)** | Jardin urbain sur mesure avec assise en robinier saturé - *Sanded (grooved) hot lacquered steel* | *Specific urban garden with stained black locust slats* • 6- Bressuire (79) | **Acier thermolaqué mat** | Jardin urbain A-LINÉA spécifique - *Matt hot lacquered steel* | *Specific A-LINÉA urban garden*



ASSISES

SEATS

Les bancs, banquettes, assis debout, chaises autant de solutions pour profiter de la nature urbaine. Inciter à prendre le temps dans un parc, sur une rive ou bien au cœur de la ville. Nous vous proposons des assises avec végétalisation telle que la gamme HEDERA ou A-LINÉA (p. 76-77).

ATECH s'adapte à chaque besoin. Il vous sera possible de les personnaliser avec une couleur, une découpe laser ou bien une matière différente. A vous de choisir !

Benches, backless benches, standing seats, chairs are all solutions for enjoying urban nature. Relax in a park, on a bank or in the heart of a city. We offer green seats such as the HEDERA or A-LINÉA range (p. 76-77).

*You will be able to customize these seats with a color, a laser cut or a different material. **ATECH** adapts to each need.*



HEDERA

Structure : Acier peint | **Assise :** Bois stratifié 4 coloris au choix p. 113 | **Bac de culture :** Polyéthylène recyclable (banquette) | **Option :** Sans accoudoir (banquette)

Structure : Hot lacquered steel | **Seat :** Laminated wood 4 colors at your choice p. 113 | **Planting liner :** Recycled polyethylene (backless bench) | **Option :** Without armrest (backless bench)



BANC
BENCH

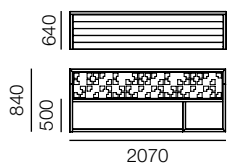

BANQUETTE
BACKLESS BENCH

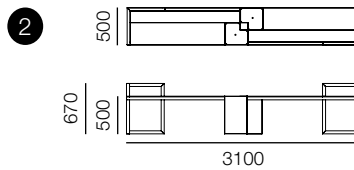
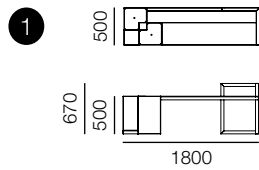

ASSIS-DEBOUT
STANDING-SEAT

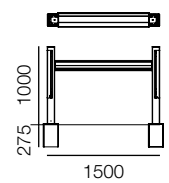

BANQUETTE SIMPLE
SINGLE BACKLESS BENCH

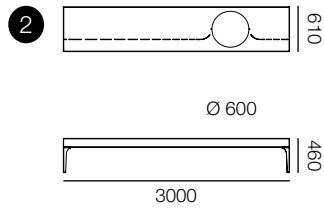
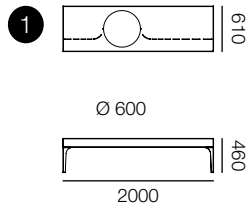

BANQUETTE DOUBLE
DOUBLE BACKLESS BENCH

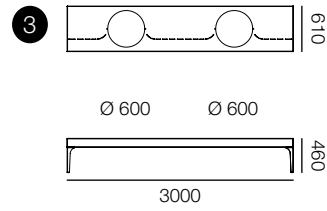

ASSIS-DEBOUT
STANDING-SEAT

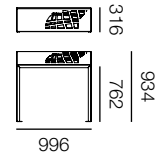

Structure : Acier peint | **Option :** Pot de fleurs Extravase p. 47

Structure : Hot lacquered steel | **Option :** Extravase flower pot p. 47

A-LINÉA



techniques

Fiches

BANC ENFANT
CHILDREN BENCH

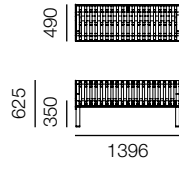

BANC ADULTE
ADULT BENCH

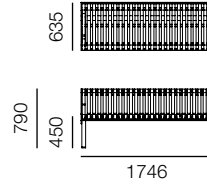

BANQUETTE
BACKLESS BENCH

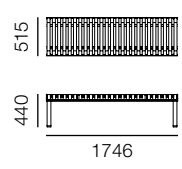



techniques
Fiches



Ohévilly-Larue (94)
Coloris spécifiques
Specific colours

PASTEL

Structure : Acier peint, coloris p. 113
| Option : Pot de fleurs Amphor p. 44
(banquette circulaire)

Structure : Hot lacquered steel, color chart p. 113
| Option : Flower pot Amphor p. 44
(circular backless bench)



Valpacos (Portugal)

BANQUETTE CIRCULAIRE
CIRCULAR BENCH

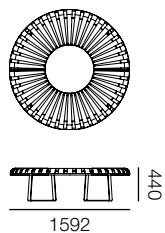

CHAISE
CHAIR

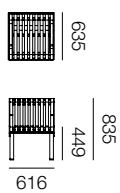
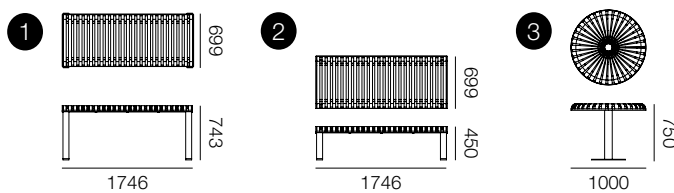

TABLE
TABLE





Fiches

techniques

ORIGAMI

Structure : Acier peint | **Assise et dossier :** Lames bambou, bois exotique, robinier saturé ou chêne saturé p. 113

Structure : Hot lacquered steel | **Seat and back :** Slats in bamboo, exotic wood, stained robinia or stained oak p. 113



Paris (75)



Acier inoxydable
Stainless steel

BANC
BENCH

BANQUETTE
BACKLESS BENCH

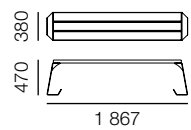
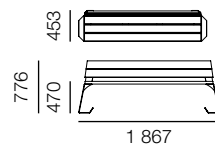

BANC
BENCH

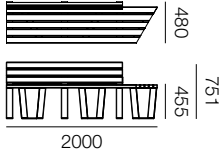

BANQUETTE
BACKLESS BENCH

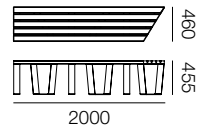

Acier corten sablé, activé et stabilisé naturellement
Sanded, activated and naturally stabilized corten steel



Colmars-les-Alpes (04)
Acier corten sablé, activé et stabilisé naturellement / Lames en pin
Sanded, activated and naturally stabilized corten steel / Pine slats

Structure : Acier peint | **Assise et dossier :** Lames bambou, bois exotique, robinier saturé ou chêne saturé p. 113

Structure : Hot lacquered steel | **Seat and back :** Slats in bamboo, exotic wood, stained robinia or stained oak p. 113

C-NATURA



techniques

Fiches

BANC
BENCH

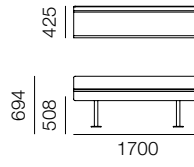

BANQUETTE
BACKLESS BENCH

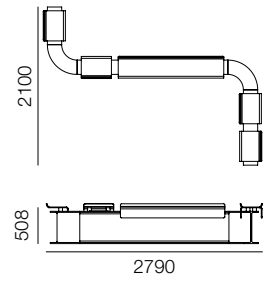



techniques
Fiches



Rochefort (17)

SQUARE

Structure : Acier peint

Structure : Hot lacquered steel



Les-Mathes-la-Palmyre (17)

CHAISE
CHAIR

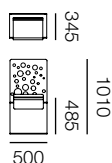

ASSISE SANS DOSSIER
SEAT WITHOUT BACK

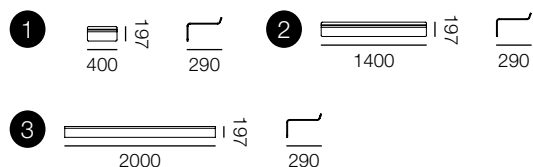

ASSISE AVEC DOSSIER
SEAT WITH BACK

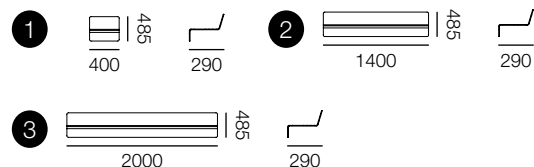
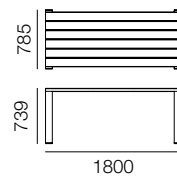
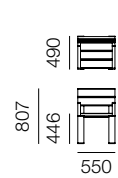

TABLE
TABLE



CHAISE
CHAIR





techniques
Fiches



Carbon-Blanc (33)

SYNERGIE

Structure : Acier peint | **Assise et dossier** : Lames bambou, bois exotique, robinier saturé, chêne saturé ou plastique recyclé p. 113 | **Option** : Accoudoir (banc)

Structure : Hot lacquered steel | *Seat and back* : Slats in bamboo, exotic wood, stained robinia, stained oak or recycled plastic p. 113 | *Option* : Armrest (bench)



Ste-Marie-de-Ré (17)

BANC
BENCH

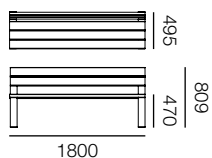

BANQUETTE
BACKLESS BENCH

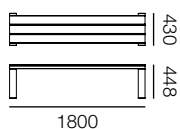



PRODUITS COMPLÉMENTAIRES

ADDITIONAL PRODUCTS

La nature en ville intègre également la propreté, la sécurité ainsi que la mobilité douce. Découvrez nos options cendriers, protège pluie et nos poubelles de tri. Notez que nos barrières florales sont munies de [réserve d'eau](#) et nos potelets d'une solution PMR. Enfin, n'oubliez pas nos solutions de gestion des pieds d'arbre afin des protéger pour qu'ils perdurent.

Poubelle, grille d'arbre, barrière, potelet, support-vélo, il vous sera possible de les personnaliser avec une couleur, une découpe laser ou bien une matière différente. A vous de choisir ! [ATECH](#) s'adapte à chaque besoin.

Nature in the city also incorporates cleanliness, safety and soft mobility. Discover our options: ashtray, rain cover and our sorting bins. Our floral barriers are provided with a [water reserve](#) and our bollards with a [PRM](#) solution. Finally, don't forget our tree stand management solutions to protect them so that they last.

Bin, tree grate, barrier, bollard, cycle rack, you will be able to customize them with a color, a laser cut or a different material. It's up to you ! [ATECH](#) adapts to each need.

LA GESTION DES PIEDS D'ARBRE

TREE FOOT MANAGEMENT



1- Pontoise (95) | **Acier corten sablé et activé** | Bac sans fond panneaué sur mesure - *Sanded and activated corten steel* | *Specific planter without bottom* • 2- Cergy (95) | **Acier corten sablé et activé** | Bordure sur mesure avec découpe laser - *Sanded and activated corten steel* | *Specific edging with laser cut* • 3- Rennes (35) | **Acier corten sablé, activé et stabilisé naturellement** | Bac sans fond sur mesure - *Sanded, activated and naturally stabilized corten steel* | *Specific planter without basis*

BORDURES POUR AMÉNAGER LE PAYSAGE

EDGINGS FOR LANDSCAPING

BORDURE DROITE

STRAIGHT EDGE

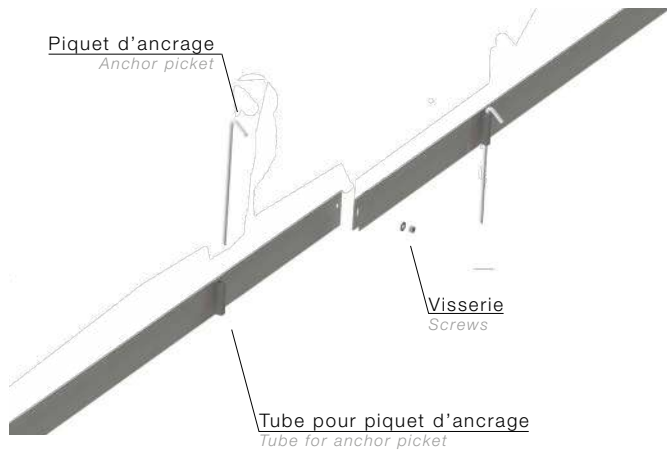

ANGLE BORDURE DROITE

CORNER FOR STRAIGHT EDGE



BORDURE PLIÉE

FOLDED EDGE

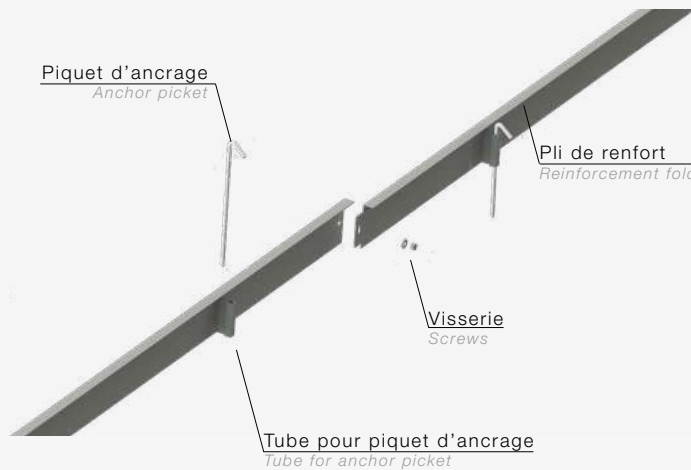

ANGLE BORDURE PLIÉE

CORNER FOR FOLDED EDGE



LA GESTION DES PIEDS D'ARBRE

TREE FOOT MANAGEMENT



7- Paris (75) | **Acier thermolaqué brillant** | Bac de fleurissement Classique spécifique - *Bright hot lacquered steel* | *Specific Classique planter* • 8- Montesson (78) | **Acier corten sablé et activé** | Bac sans fond panneaué sur mesure - *Sanded and activated corten steel* | *Specific planter without bottom* • 9- Rochefort (17) | **Acier thermolaqué brillant** | Banquette simple A-LINÉA spécifique - *Bright hot lacquered steel* | *Specific single backless bench A-LINÉA*



Fiches techniques

GRILLE D'ARBRE

TREE GRATE

Structure : Acier | **Épaisseur :** 4 mm (résistance piétonne), 6 ou 10 mm | **Fixation :** Cadre support en cornière avec pattes de scellement, assemblage des deux demi-grilles par visserie fournie

Structure : Steel | **Thickness :** 4 mm (pedestrian resistance), 6 or 10 mm | **Fixing :** Support frame in angle iron with anchoring legs, assembling of the two half grids by included screws



Vauvert (30)

HEDERA

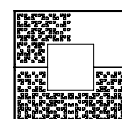

1000 - 1500
2000

A-LINÉA

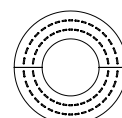

1000 - 1500
2000

SQUARE

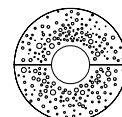

1000 - 1500
2000

C-NATURA

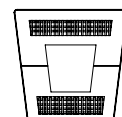

1000 - 1500
2000

DUALIS

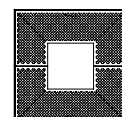

1000 - 1500
2000

ORIGAMI

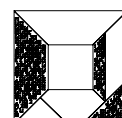

1000 - 1500
2000



Fiche

technique



HEDERA

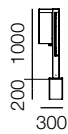

Structure : Acier peint, bac intérieur
Support végétal : Filin inox | **Fixation** :
Sur platine avec fourreau de réservation
Option : Cendrier 40 cl. avec nettoyage
manuel facilité

Structure : Hot lacquered steel, liner
bucket | **Floral support** : Stainless steel
rope | **Fixing** : Vegetal contener sleeve with
base plate | **Option** : Ashtray 40 cl. with
easy manual cleaning

Poubelle végétale

Vegetable bin

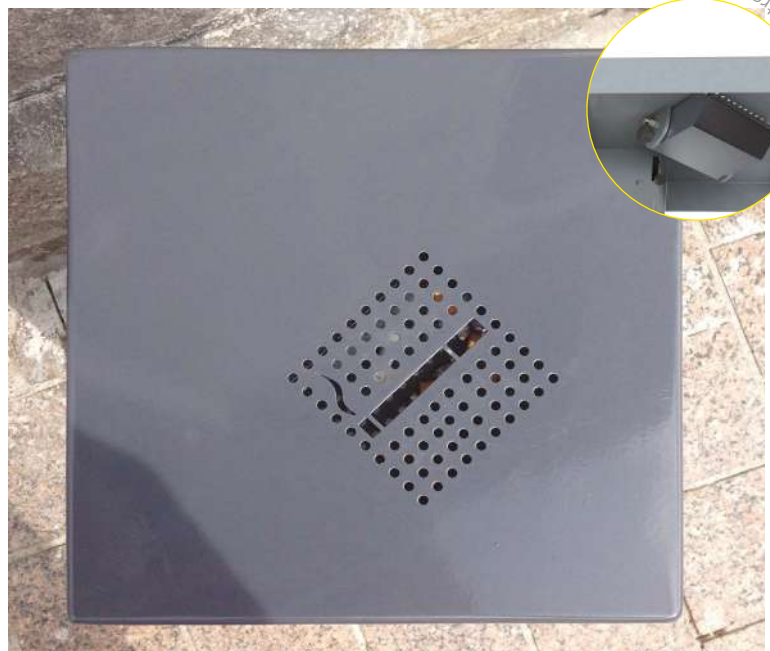

Ashtray
Option cendrier

CENDRIER ET PROTÈGE PLUIE

ASHTRAY AND RAIN COVER

Structure : Acier peint, porte sac (PASTEL, A-LINÉA, SYNERGIE), bac intérieur (PASTEL, SQUARE)
| Fixation : À spitter au sol **| Options :** Cendrier 20 cl. avec nettoyage manuel facilité, protège pluie
 Cendrier développé en partenariat avec le service propreté d'Angers Loire Métropole

Structure : Hot lacquered steel, bag holder (PASTEL, A-LINÉA, SYNERGIE), liner bucket (PASTEL, SQUARE)
| Fixing : To fix to the ground **| Options :** Ashtray 20 cl. with easy manual cleaning, rain cover
 Ashtray developed in partnership with the Angers Loire Métropole cleanliness department.



Coloris p. 113
 Color chart p. 113



Angers (49)

Loudéac (22)

PASTEL

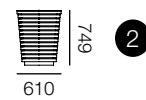
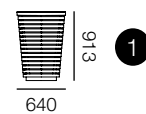

A-LINÉA

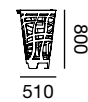

SYNERGIE

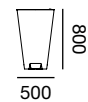

SQUARE

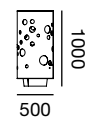

techniques
 Fiches



POUBELLE SIMPLE ET DE TRI

SINGLE AND SORTING BIN

Structure : Acier peint, porte sac | **Fixation :** À spitter ou sur platine réhaussée | **Option :** Cendrier 40 cl. avec nettoyage manuel facilité

Structure : Hot lacquered steel, bag holder | **Fixing :** To fix to the ground or with a raised plate | **Option :** Ashtray 40 cl. with easy manual cleaning

DUALIS

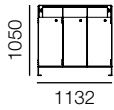
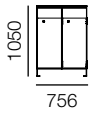
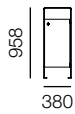

Plestin-les-Grèves (22)



Castelnau-de-Médoc (33)
Bi-couleur avec option cendrier, sur platine réhaussée
Bi-color with ashtray option, with a raised plate



Acier inoxydable brossé
Stainless steel brushed

Structure : Acier peint, porte sac
Fixation : À spitter au sol

Structure : Hot lacquered steel, bag holder
Fixing : To fix to the ground

ORIGAMI

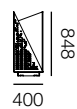

technique
 Fiche

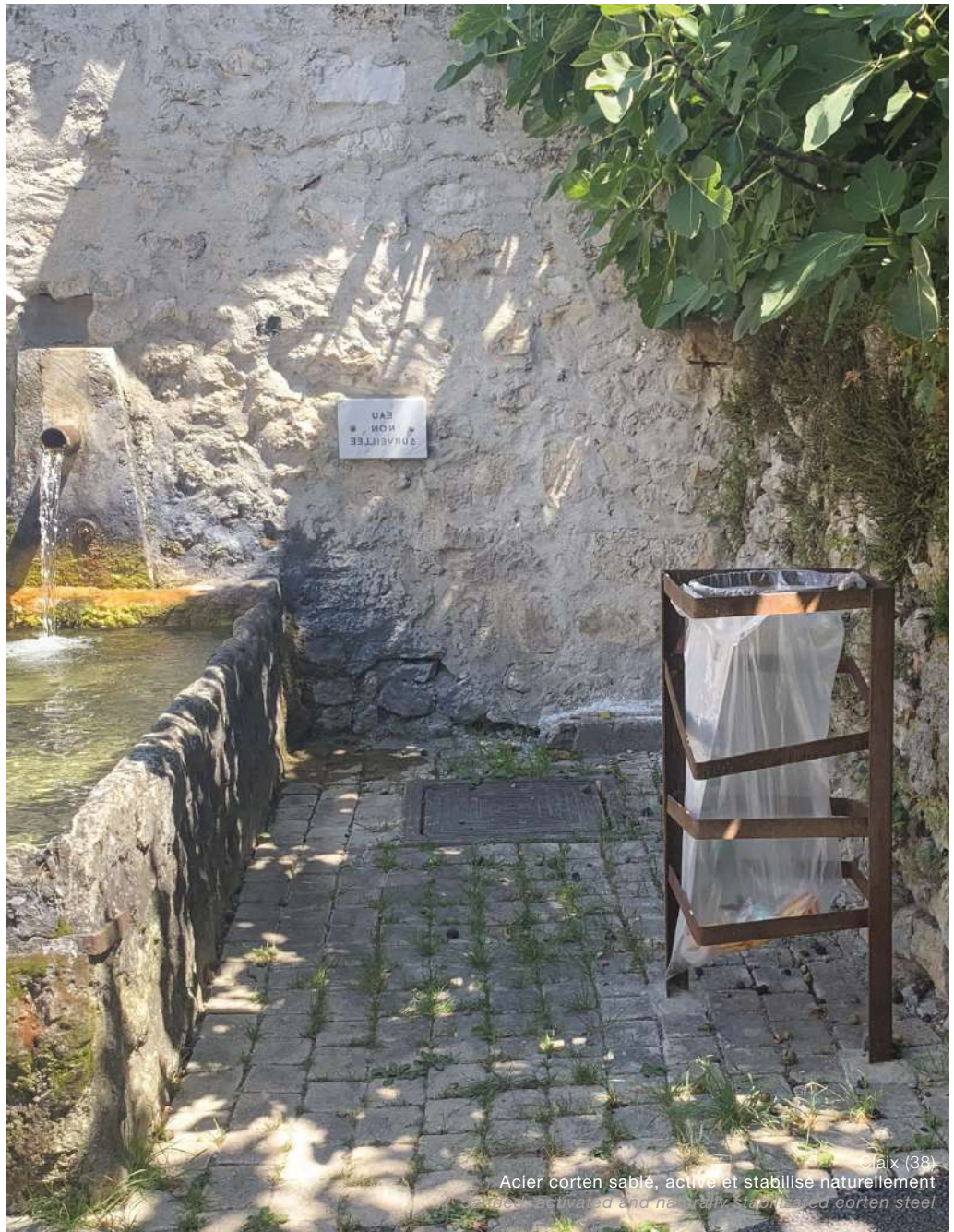

C-NATURA

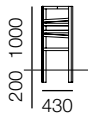

DUALIS

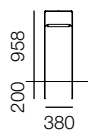

Craix (39)
Acier corten sablé, activé et stabilisé naturellement
Sanded, activated and naturally stabilized corten steel

Structure : Acier peint, porte sac
Fixation : À spitter au sol (SQUARE) ou à sceller (DUALIS, C-NATURA)

Structure : Hot lacquered steel, bag holder
Fixing : To fix to the ground (SQUARE) or to be embedded (DUALIS, C-NATURA)

SQUARE



Fiches

techniques



technique

Fiche

POUBELLE VIGIPIRATE

ANTI-ATTACK BIN

Structure : Acier peint, porte sac | **Fixation :** À sceller

Structure : Hot lacquered steel, bag holder | **Fixing :** To be embedded



ORIGAMI

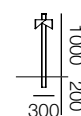

Acier inoxydable brossé
Stainless steel brushed



HEDERA

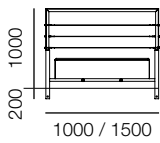

PASTEL

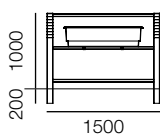

Le-Faou (29)

Structure : Acier peint | **Fleurissement :** Balconnière polyéthylène, filins inox (HEDERA) | **Fixation :** À sceller, sur platine ou sur fourreau

Structure : Hot lacquered steel | **Floral support :** Polyethylene flowerbox, stainless steel rope (HEDERA) | **Fixing :** To be embedded, on base plate or by sleeve

BARRIÈRE FLORALE

FLORAL BARRIER



Fiches techniques



Plaisance-du-Touch (31)
Coloris p. 113
Color chart p. 113



techniques

Fiches

BARRIÈRE FLORALE AVEC TREILLAGE

FLORAL BARRIER WITH TRELLIS

Structure : Acier peint | **Fleurissement :** Balconnière polyéthylène amovible | **Fixation :** À sceller, sur platine ou sur fourreau

Structure : Hot lacquered steel | **Floral support :** Removable polyethylene flowerbox | **Fixing :** To be embedded, on base plate or by sleeve



Le-Neubourg (27)



A-LINÉA

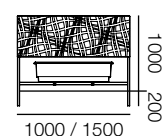

DUALIS

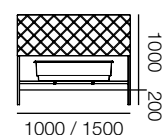

SQUARE

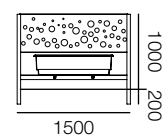

C-NATURA

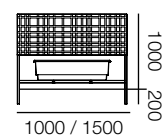

HEDERA

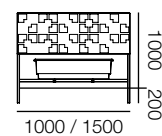

ORIGAMI

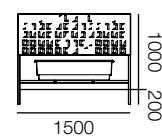



BARRIÈRE CLASSIQUE

CLASSICAL BARRIER

Structure : Acier peint | **Lames :** Bambou, bois exotique, robinier saturé ou chêne saturé p. 113
Fixation : À sceller, sur platine ou sur fourreau

Structure : Hot lacquered steel | **Slats :** Bamboo, exotic wood, stained robinia or stained oak p. 113
Fixing : To be embedded, on base plate or by sleeve

C-NATURA

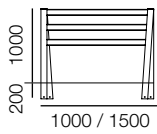

Colmars (04)
Acier corten sablé, activé et stabilisé naturellement (structure et lames)
Sanded, activated and naturally stabilized corten steel (structure and slats)



Mazières-en-Mauges (49)

SYNERGIE
POTEAUX CARRÉS
SQUARE POSTS

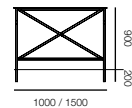

Château-du-Loir (72)
Coloris spécifique

Structure : Acier peint | **Fixation :** À sceller, sur platine ou sur fourreau

Structure : Hot lacquered steel | **Fixing :** To be embedded, on base plate or by sleeve

SYNERGIE
POTEAUX ROUNDS
ROUND POSTS

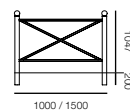



HEDERA

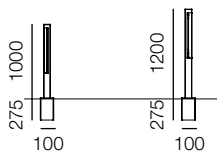

Structure : Acier peint | **Support végétal :** Filin inox (HEDERA) | **Fixation :** À sceller, sur platine ou sur fourreau (ORIGAMI), sur platine avec fourreau de réservation (HEDERA)

Structure : Hot lacquered steel | **Floral support :** Stainless steel rope (HEDERA) | **Fixing :** To be embedded, on base plate or by sleeve (ORIGAMI), vegetal container sleeve with base plate (HEDERA)



ORIGAMI

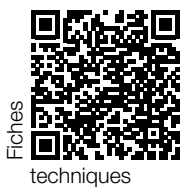
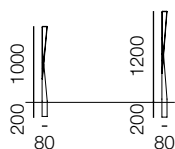

Acier inoxydable brossé
Stainless steel brushed



POTELET

BOLLARD

Structure : Acier peint | **Fixation :** À sceller, sur platine ou sur fourreau

Structure : Hot lacquered steel | **Fixing :** To be embedded, on base plate or by sleeve



DUALIS

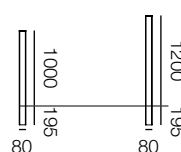



**SYNERGIE
À BOULE**
BOWL TOP CAP

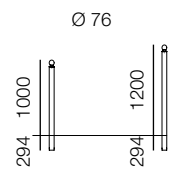

**SYNERGIE
À GORGE**
GORGE TOP CAP

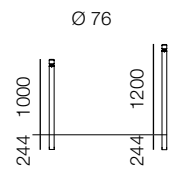

Dugny-sur-Meuse (55)

Structure : Acier peint | **Fixation :**
À sceller, sur platine ou sur fourreau
| Option : PMR

Structure : Hot lacquered steel | **Fixing :**
To be embedded, on base plate or by
sleeve | **Option :** PRM

**SYNERGIE À
TÊTE BOMBÉE**
CONVEX TOP CAP

Ø 60 / Ø 76 / Ø 90

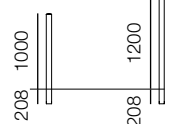

Le Teich (33)

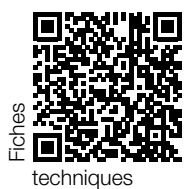



techniques

Fiches

POTELET PMR

PRM BOLLARD

Structure : Acier peint | **Empiècement décoratif :** Bambou, bois exotique, robinier saturé ou chêne saturé p. 113 (C-NATURA) | **Fixation :** À sceller, sur platine ou sur fourreau | **Option :** PMR

Structure : Hot lacquered steel | **Decorative yoke :** Bamboo, exotic wood, stained robinia or stained oak p. 113 (C-NATURA) | **Fixing :** To be embedded, on base plate or by sleeve | **Option :** PRM



Colmars-les-Alpes (04)
Acier corten sablé, activé et stabilisé naturellement
Sanded, activated and naturally stabilized corten steel

A-LINÉA

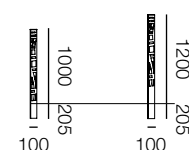

C-NATURA

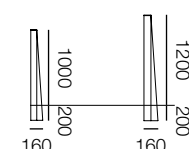

PASTEL

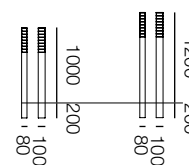

SQUARE

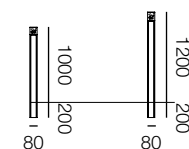

Coloris p. 113
Color chart p. 113



Option PMR
PRM option

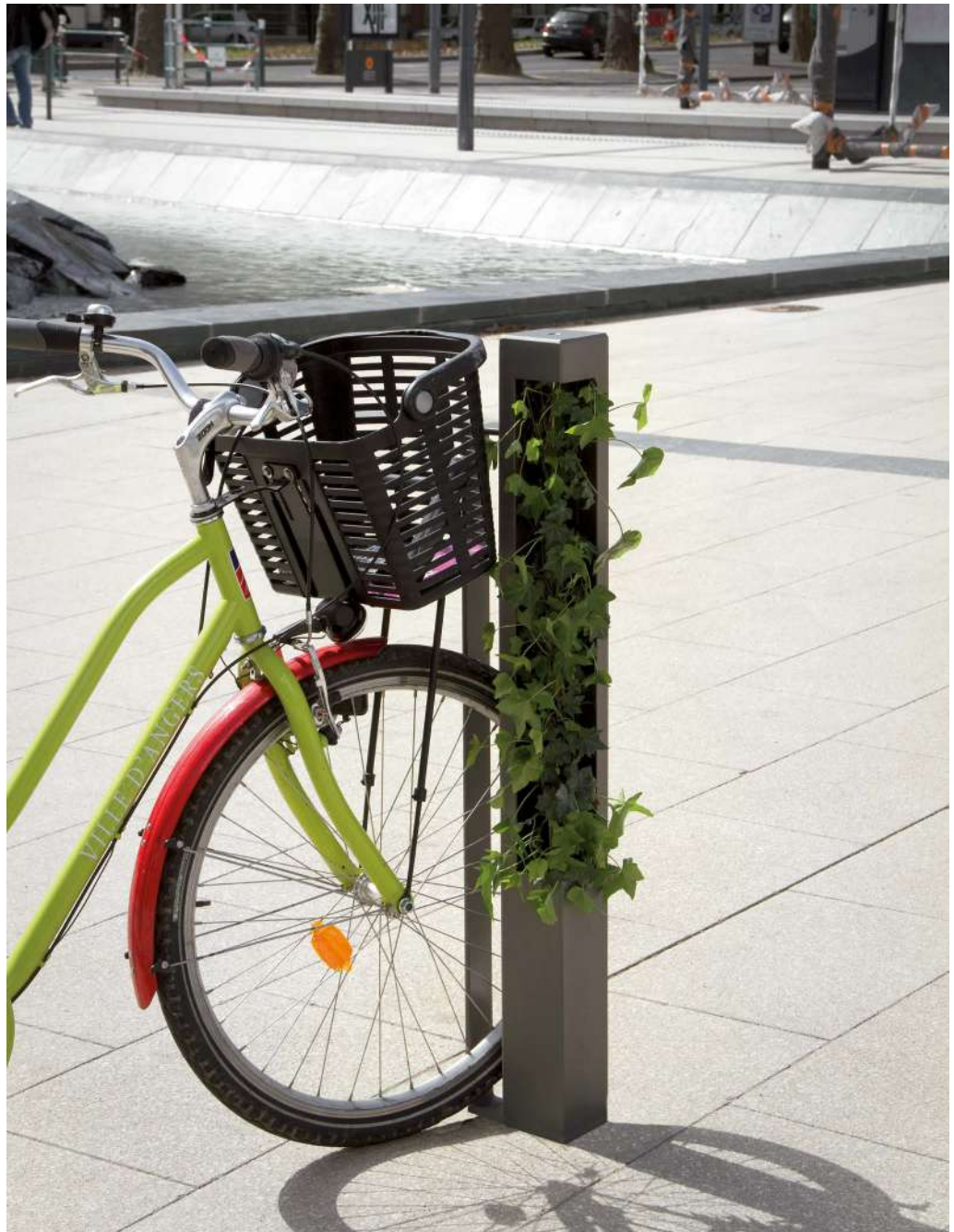

HEDERA

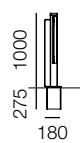

Structure : Acier peint | **Support végétal** : Filin inox (HEDERA) | **Fixation** : À spitter au sol (C-NATURA), sur platine avec fourreau de réservation (HEDERA)

Structure : Hot lacquered steel | **Floral support** : Stainless steel rope (HEDERA) | **Fixing** : To fix to the ground (C-NATURA), vegetal container sleeve with base plate (HEDERA)

C-NATURA



Acier corten sablé, activé et stabilisé naturellement
Sanded, activated and naturally stabilized corten steel

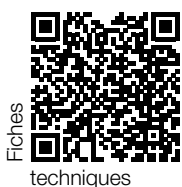



SUPPORT-VÉLO

CYCLE-RACK

Structure : Acier peint | **Fixation :** À sceller ou sur platine

Structure : Hot lacquered steel | **Fixing :** To be embedded or on base plate



Cosne-Cours-sur-Loire (58)
Coloris p. 113
Color chart p. 113

PASTEL

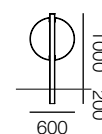

SYNERGIE

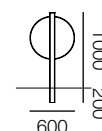



SUPPORT-VÉLO

CYCLE-RACK

Structure : Acier peint | **Fixation :** À sceller ou sur platine

Structure : Hot lacquered steel | **Fixing :** To be embedded or on base plate

DUALIS

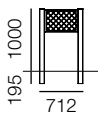

ORIGAMI

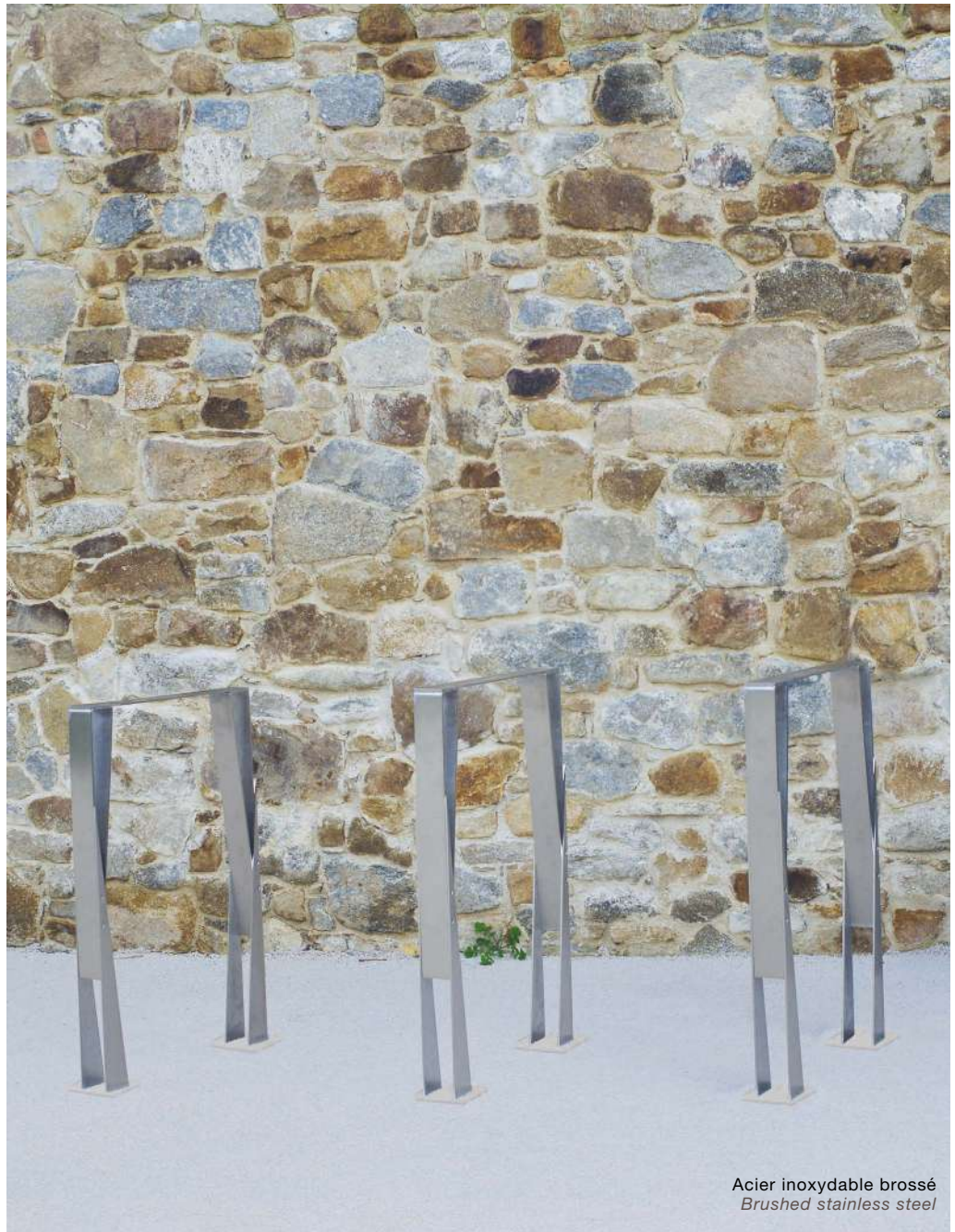
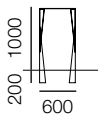

Acier inoxydable brossé
Brushed stainless steel



A-LINÉA

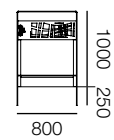

Structure : Acier peint | **Fixation :** À sceller ou sur platine

Structure : Hot lacquered steel | **Fixing :** To be embedded or on base plate

SQUARE

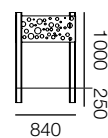

INDEX

INDEX

6

BACS DE FLEURISSEMENT PLANTERS



8 ORIGAMI



9 Cube



10 Classique



11 DUALIS



12 Asyma



13 Aérés



14 Pyrou



15 HEDERA



16 Kesa



17 Concave



18 Cléo



19 Mosaïque



20 C-NATURA



21 Atempo



22 Eole



23 SYNERGIE



24 Octogone



25 Patine



26 Perga



27 Extrabac



28 A-LINÉA



29 PASTEL



30 Contrario



31 SQUARE

40

POTS DE FLEURS FLOWER POTS



42 Gal'B



43 Saphir



44 Amphor



45 Vase



46 Extravase
Demi



47 Extravase



48 Rectiligne



49 Pila



50 Quadri

52 JARDINS URBAINS URBAN GARDENS



54 Olympe



56 Prisme



58 A-LINÉA



60 Oasis



62 SQUARE



64 C-NATURA

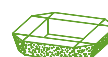

66 Mosaïque



68 FreshCity

74 ASSISES SEATS



76 HEDERA



77 A-LINÉA



78 PASTEL



80 ORIGAMI



81 C-NATURA



82 SQUARE



84 SYNERGIE

86 PRODUITS COMPLÉMENTAIRES ADDITIONAL PRODUCTS



91 Grilles d'arbre
Tree grates

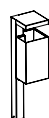

92 Poubelles
Bins



98 Barrières
Barriers



102 Potelets
Bollards



106 Supports vélo
Cycle racks

MATÉRIATHÈQUE

MATERIAL LIBRARY

MÉTAL ET FINITIONS

METAL AND FINISHINGS

ACIER

STEEL



Coloris disponibles avec la référence RAL ou AkzoNobel.

Colours available with the reference RAL or AkzoNobel

ALUMINIUM

ALUMINIUM



Coloris disponibles avec la référence RAL ou AkzoNobel.

Colours available with the reference RAL or AkzoNobel.



Exemple d'anodisation cuivre.

Example of a copper anodizing.

ACIER CORTEN*

CORTEN*



Sablé activé et stabilisé
sandblasted activated and naturally stabilized

Sablé activé et stabilisé mat
sandblasted activated and stabilized matte

L'**acier** est un alliage qui contient du fer et du carbone. Sa grande robustesse est sa principale caractéristique. Il doit être traité avant sa finition. Il est disponible en finition **thermolaqué grainé (sablé), brillant et mat.**

*Steel is an alloy that contains iron and carbon. Its great robustness is its main characteristic. It must be treated before it is finished. It is available in the finishes **sanded (grooved) hot laquered, bright and matt.***

L'**aluminium** est un matériau léger ayant une forte résistance à la corrosion. Il est également très malléable, ce qui le rend idéal pour effectuer des courbes ou diverses formes créatives. Il est disponible en finition **thermolaqué (grainé, brillant, mat), brossé, anodisé (brillant ou satiné), ou poli-anodisé.**

*Aluminum is a lightweight material with high corrosion resistance. It is also very malleable, which makes it ideal for curves or various creative shapes. It is available in **powder coated (grained, glossy, matte), brushed, anodized (glossy or satin), or polished-anodized finishes.***

L'**acier corten** est un alliage qui contient du cuivre, du chrome, du nickel molybdène ainsi que du phosphore. C'est une matière naturelle se couvrant d'une couche protectrice appelée «patine», qui se teinte de nuances marron évoluant pendant 18 mois avant d'atteindre sa couleur finale. Tout au long du processus, les changements de couleurs surviennent en fonction de la lumière et de la température. Il est disponible en finition **sablé** (permet d'accélérer la patine), **sablé activé** (permet d'être livré d'un produit patiné dans sa globalité), et **sablé activé et stabilisé** (permet de stopper la patine afin de ne pas tâcher le sol notamment). Pour cette dernière il existe deux techniques, soit le produit est stabilisé naturellement (**sablé activé et stabilisé naturellement**) et alors le procédé à une durée d'environ 4 mois (l'acier peint coloris Mars 2525 finition sablé étant une alternative) OU bien le produit est vernis avec une finition mat et cuit au four (**sablé activé et stabilisé mat**), l'acier peint coloris RAL 8017 étant une alternative.

*Corten steel is an alloy that contains copper, chromium, nickel molybdenum and phosphorus. It's a natural material that covers itself with a protective layer called « patina » which tints itself of evolving brown shades over a period of 18 months. All throughout the process, color changes occur according to the light and the temperature. It is available in the finishes **sanded** (allows the patina to be accelerated), **sanded activated** (allows the whole product to be delivered with patina) and **stabilized** (the patina is stopped and dirty stains are avoided). For the latter there are two techniques, either the product is naturally stabilized (**sandblasted activated and naturally stabilized**) and then the process has a duration of about 4 months (painted steel color Mars 2525 sanded finish is an alternative) or the product is varnished with a matte finish and baked (**sandblasted activated and stabilized matte**), painted steel color RAL 8017 is an alternative*

ACIER INOXYDABLE

STAINLESS STEEL



L'**acier inoxydable** est un alliage qui contient du fer, du chrome et du carbone. Sa grande résistance à la corrosion est sa principale caractéristique. Il est disponible en finition **brossé et poli-miroir.**

*Stainless steel is an alloy that contains iron, chromium and carbon. Its high resistance to corrosion is its main characteristic. It is available in the finishes **brushed and mirror effect.***

ZINC*

ZINC*



Le **zinc** se distingue par sa grande résistance à la corrosion. Nous le proposons en panneaux, rivetés sur un ensemble en acier galvanisé pour une optimisation des coûts. Il est disponible en finition **pré-patiné.**

*Zinc is distinguished by its high resistance to corrosion. We offer it in panels, riveted to a galvanized steel structure for cost optimization. It is available in the finish **pre-patiné.***

* Avec ces matières nous ne pouvons pas réaliser de tube.

* With these materials we cannot manufacture tube.

ZOOM SUR LES ASSISES

FOCUS ON SEATS AND PANELS

BAMBOU

BAMBOO



BOIS EXOTIQUE

EXOTIC WOOD



ROBINIER SATURÉ*

STAINED BLACK LOCUST*



CHÈNE SATURÉ*

STAINED OAK*



* Application du saturateur Rubio Monocoat couleur Teak à renouveler tous les 18 mois.
* Application of Rubio Monocoat color Teak saturator to be renewed every 18 months.

PLASTIQUE RECYCLÉ

RECYCLED PLASTIC

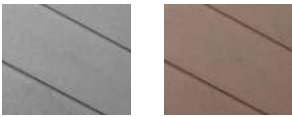

COLORIS DE PLASTIQUES RECYCLABLES POTS DE FLEURS

COLOURS OF RECYCLABLE PLASTICS FLOWER POTS

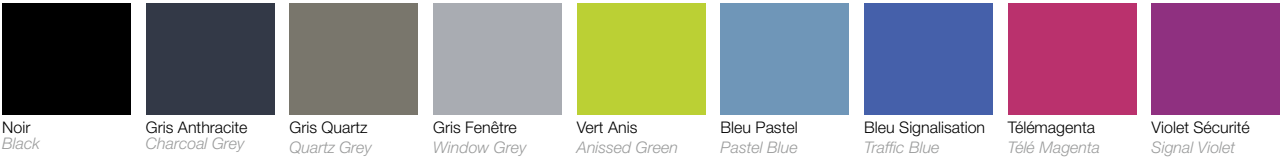

Noir
Black

Gris Anthracite
Charcoal Grey

Gris Quartz
Quartz Grey

Gris Fenêtre
Window Grey

Vert Anis
Anissed Green

Bleu Pastel
Pastel Blue

Bleu Signalisation
Traffic Blue

Télémagenta
Télé Magenta

Violet Sécurité
Signal Violet

Coloris texturés, coût supplémentaire :
Textured colors, additional cost:

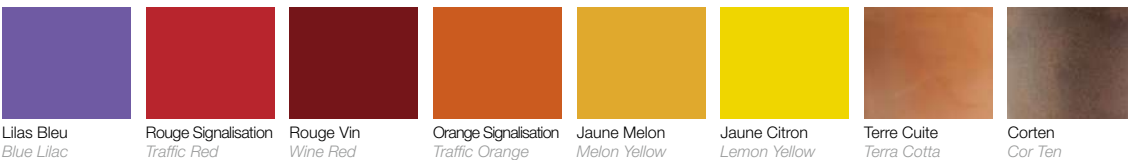

Lilas Bleu
Blue Lilac

Rouge Signalisation
Traffic Red

Rouge Vin
Wine Red

Orange Signalisation
Traffic Orange

Jaune Melon
Melon Yellow

Jaune Citron
Lemon Yellow

Terre Cuite
Terra Cotta

Corten
Cor Ten

LASURES ET PANNEAUX GAMME DUALIS

STAINS AND PANELS DUALIS RANGE

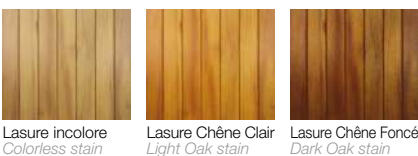

Lasure incolore
Colorless stain

Lasure Chêne Clair
Light Oak stain

Lasure Chêne Foncé
Dark Oak stain

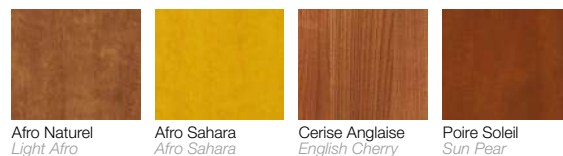

Afro Naturel
Light Afro

Afro Sahara
Afro Sahara

Cerise Anglaise
English Cherry

Poire Soleil
Sun Pear

COLORIS GAMME PASTEL

COLOURS OF PASTEL RANGE

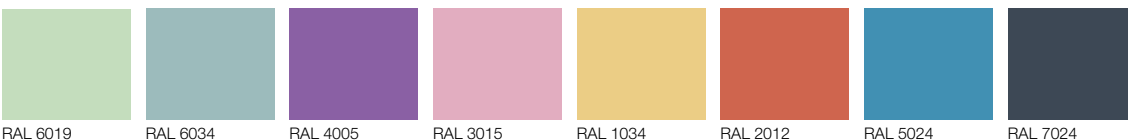

RAL 6019

RAL 6034

RAL 4005

RAL 3015

RAL 1034

RAL 2012

RAL 5024

RAL 7024

Retrouvez nos produits sur www.atech-sas.com

Find our products on www.atech-sas.com

Consultez et téléchargez-y nos fiches techniques puis abonnez-vous à nos réseaux sociaux.

Consult and download our technical sheets and follow us on our social media.

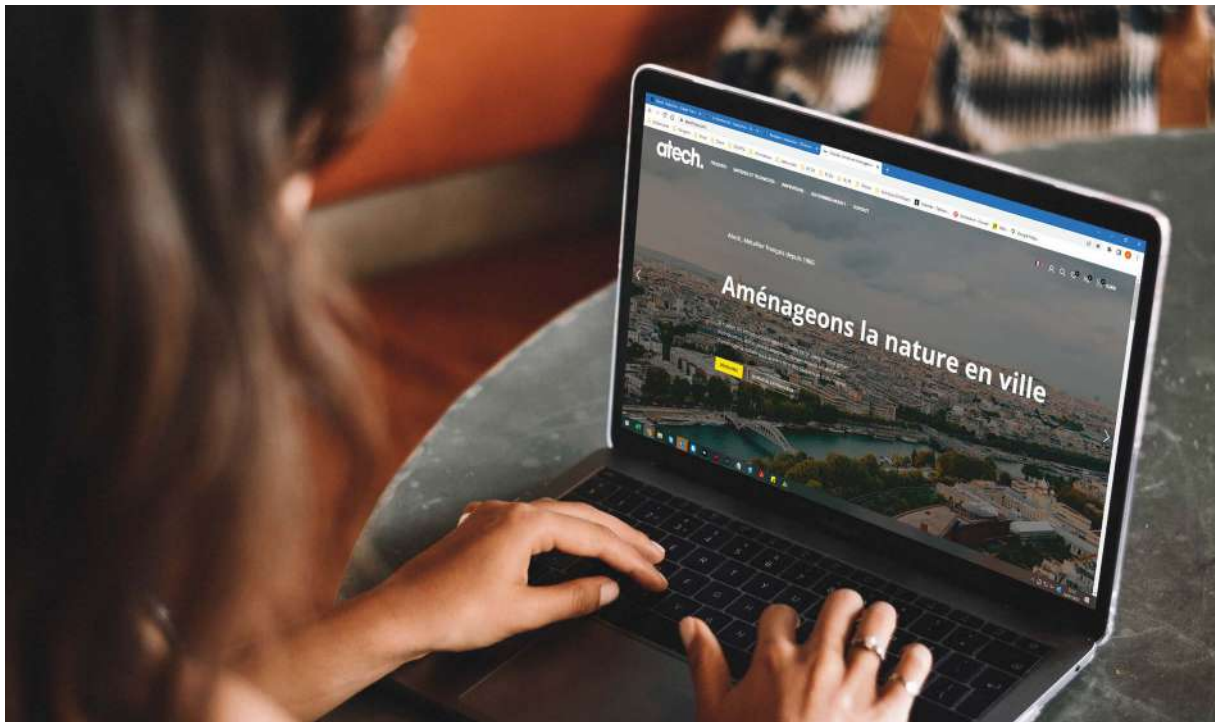

Application AUGMENT

AUGMENT app

Un projet en vue, contactez le commercial pour qu'il vous fasse une démonstration en direct.

A project in sight, contact the sales representative for a live demonstration.



RENCONTRONS-NOUS

HAVE A MEETING

ATECH SAS
ZI de l'Appentière
49280 Mazières-en-Mauges | FRANCE
Tél. +33 (0)2 41 58 57 13
Mail : info@atech-sas.com
www.atech-sas.com



Hugues JOUANNE

Port. 06 84 83 13 73

Mail : huguesjouanne@atech-sas.com



Sylvain LEGALLOIS

Port. 06 70 27 47 13

Mail : sylvainlegallois@atech-sas.com



Sylvain LEGALLOIS

Port. 06 70 27 47 13

Mail : sylvainlegallois@atech-sas.com

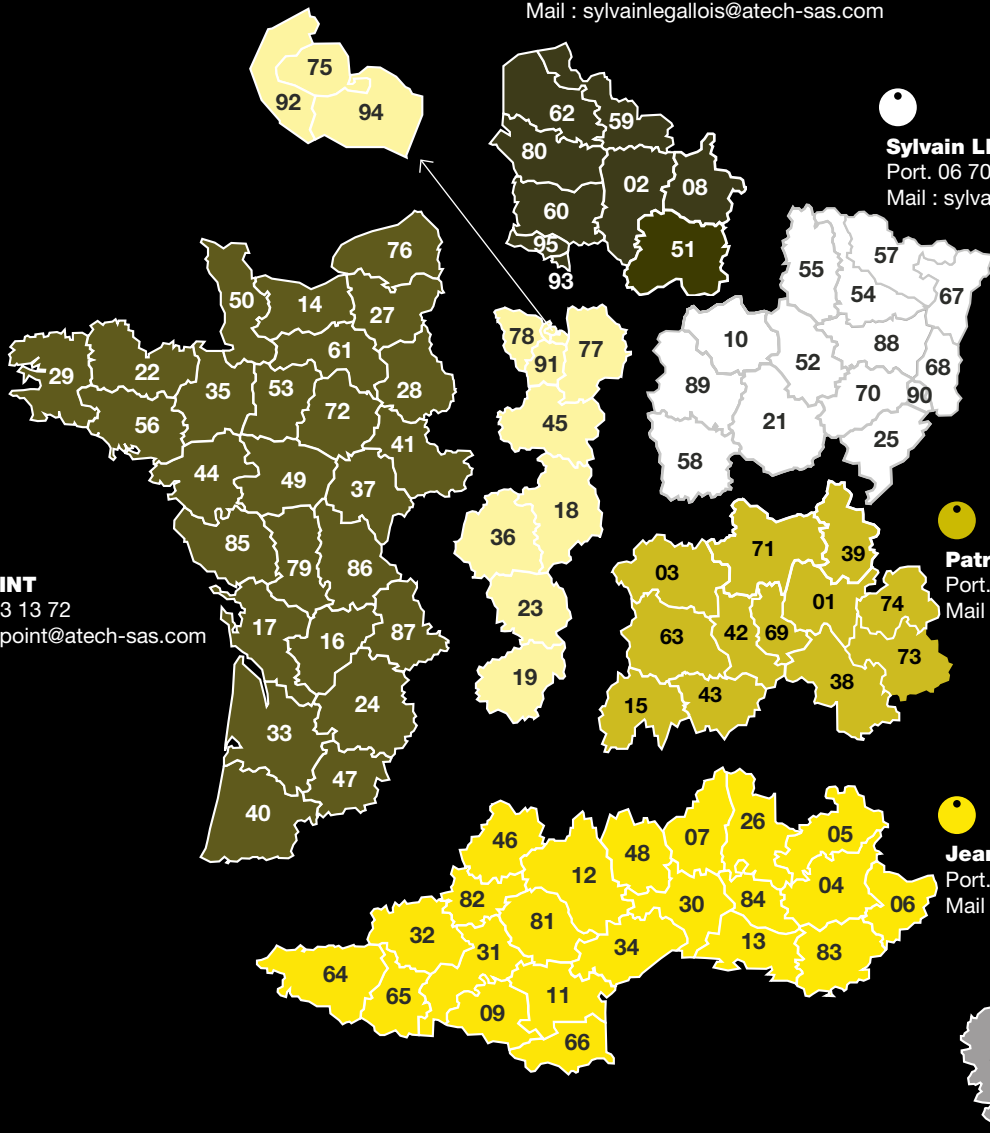

Fabrice POINT

Port. 06 84 83 13 72

Mail : fabricepoint@atech-sas.com



Patricia BECEL-LEONARD

Port. 06 08 07 08 14

Mail : patriciabecelleonard@gmail.com



Jean-Charles REY

Port. 06 30 27 87 32

Mail : jeancharlesrey@atech-sas.com

Corse - Dom Tom - International dont Monaco



Sarah DEROUET

Port. +33 (0)6 07 81 48 22

Mail : sarahderouet@atech-sas.com

GUADELOUPE

MARTINIQUE

GUYANE

MAYOTTE

RÉUNION



DÉCOUVREZ NOS BROCHURES DÉDIÉES AU FLEURISSEMENT ET À L'AMÉNAGEMENT PAYSAGER EN LES SCANNANT !

DISCOVER OUR LEAFLETS ABOUT FLOWERING AND LANDSCAPING BY SCANNING THEM!



atech.
www.atech-sas.com