

acoupanel®  
acoustic wall & ceiling

**WOODGRAIN** | **SLAT**  
acoustic panel



Feltech Manufacturing Co.,Ltd

Amata City Chonburi Industrial Estate  
700/377, Moo 6, Donhuaroh, Muang Chonburi,  
Chonburi, 20000. Thailand

+66 240 3041-2

info@feltech.co.th  
www.feltech.co.th



Meet(s) SCS Indoor  
Advantage™ Gold  
certification for  
Indoor Air Quality



EPD (EN 15804) -  
Environmental Product  
Declaration



**WOODGRAIN** | **SLAT**  
acoustic panel

Natural Maple (WS 01)



## WOODGRAIN | SLAT

acoustic panel

acoupanel® | Woodgrain slats are sustainable multi layers available in a wide variety of stunning woodgrain and colors. It is carefully crafted to ensure a unique and visually appealing installation.

Its multi layers gives highly effective sound absorption surface particularly mid-range, not only reduce noise but also diffuse sound energy that create a warm and inviting environment in any indoor space.

Product Name	acoupanel® Woodgrain Slat
Product Category	Wall and ceiling
Composition	Polyester fibers with >60% recycled content
Weight	3,800 gram/sq.m +/-10%
Density	200 kgs/Cubic.m +/-10%
Thickness	19 mm +/-10%
Size	1,200 x 2,800 mm +/-1%

Performance	
Color Fastness to Light	> 6, ISO 105 B02-1994
TVOC Emission	CDPH-IAQ V1.1 2017, ≤ 0.5 mg/m <sup>3</sup>
Moisture Content	<0.10% by weight
Sound Absorption	NRC 0.70 with no air gap, ISO 354

Sound Absorption Coefficients(αs)

(Hz)	125	250	500	1000	2000	4000
Frequency f	0.04	0.26	0.69	0.94	0.90	0.82

The specifications are subject to normal manufacturing variations. Due to continued product and performance development, the manufacturer reserves all right to vary specification without prior notice.

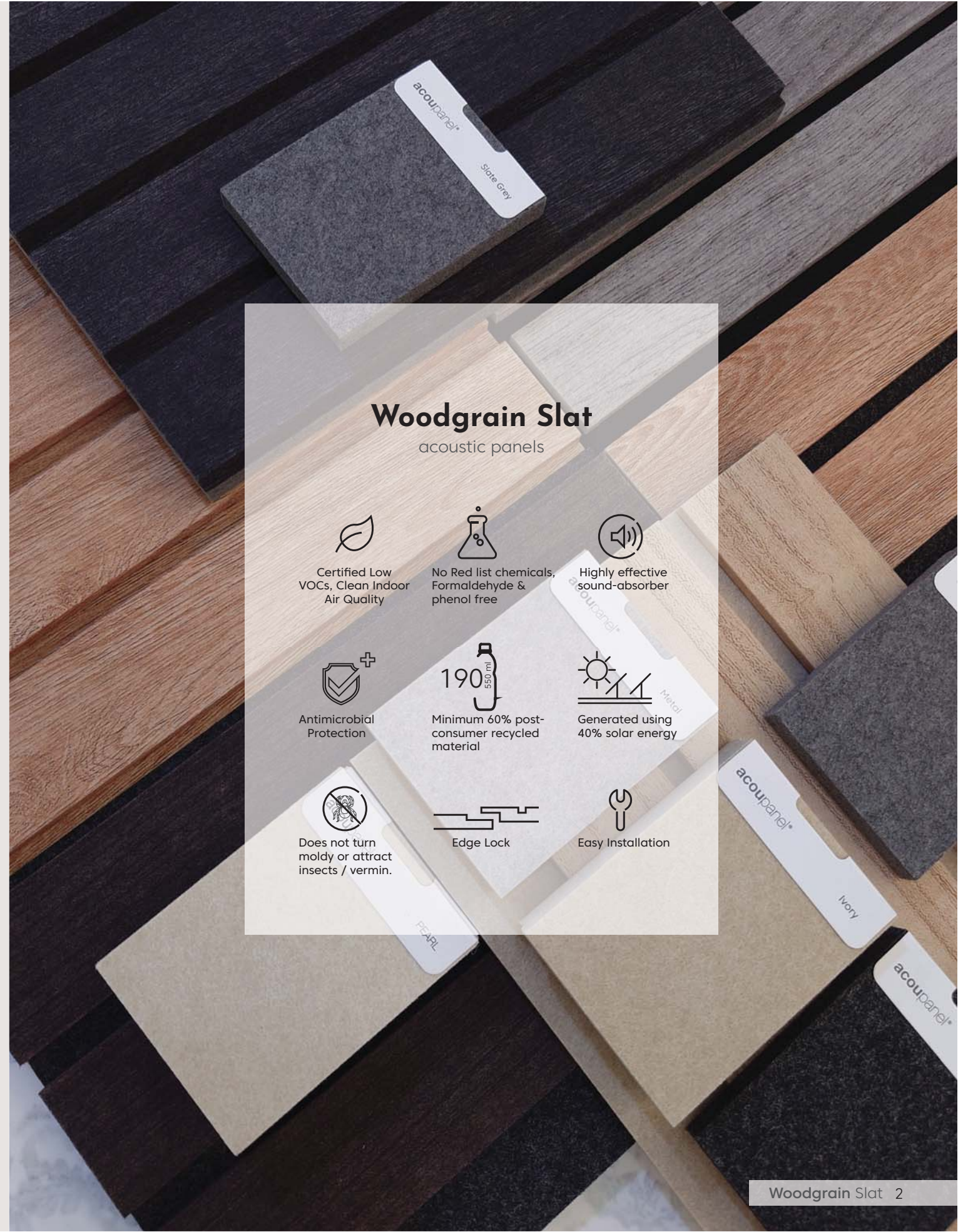

### Woodgrain Slat

acoustic panels

- Certified Low VOCs, Clean Indoor Air Quality
- No Red list chemicals, Formaldehyde & phenol free
- Highly effective sound-absorber
- Antimicrobial Protection
- 190 550 ml Minimum 60% post-consumer recycled material
- Generated using 40% solar energy
- Does not turn moldy or attract insects / vermin.
- Edge Lock
- Easy Installation

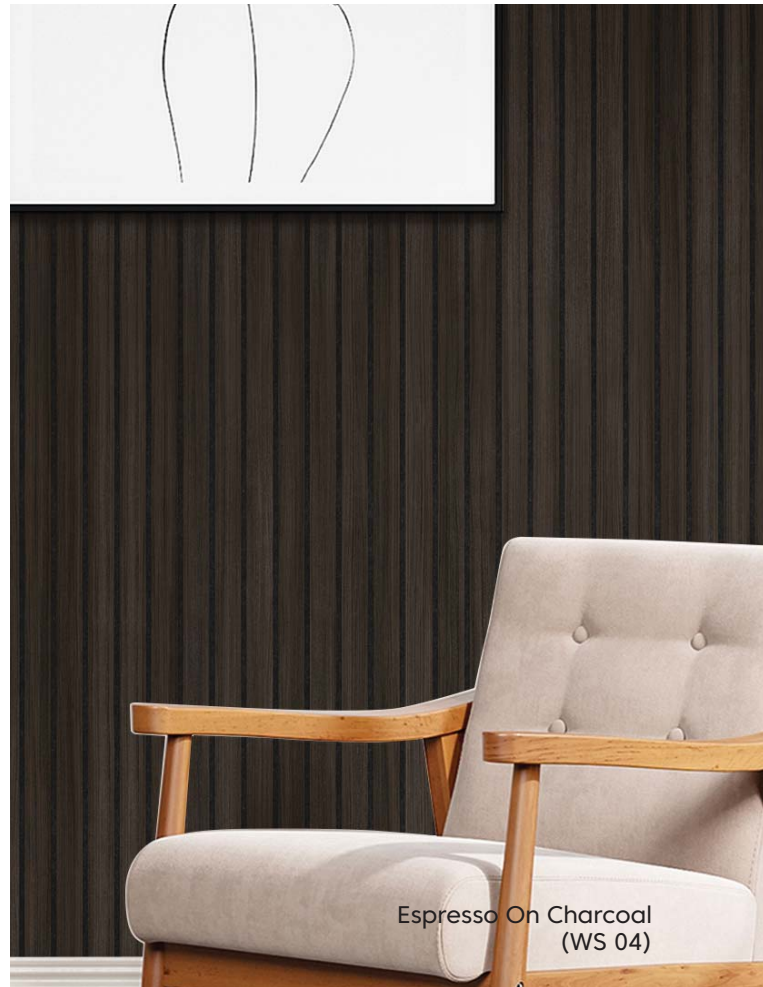

Espresso On Charcoal (WS 04)



Branwood Oak (WS 03)



America Walnut (WSP 05)



Charred Wood (WSP 06)



Natural Maple (WS 01)

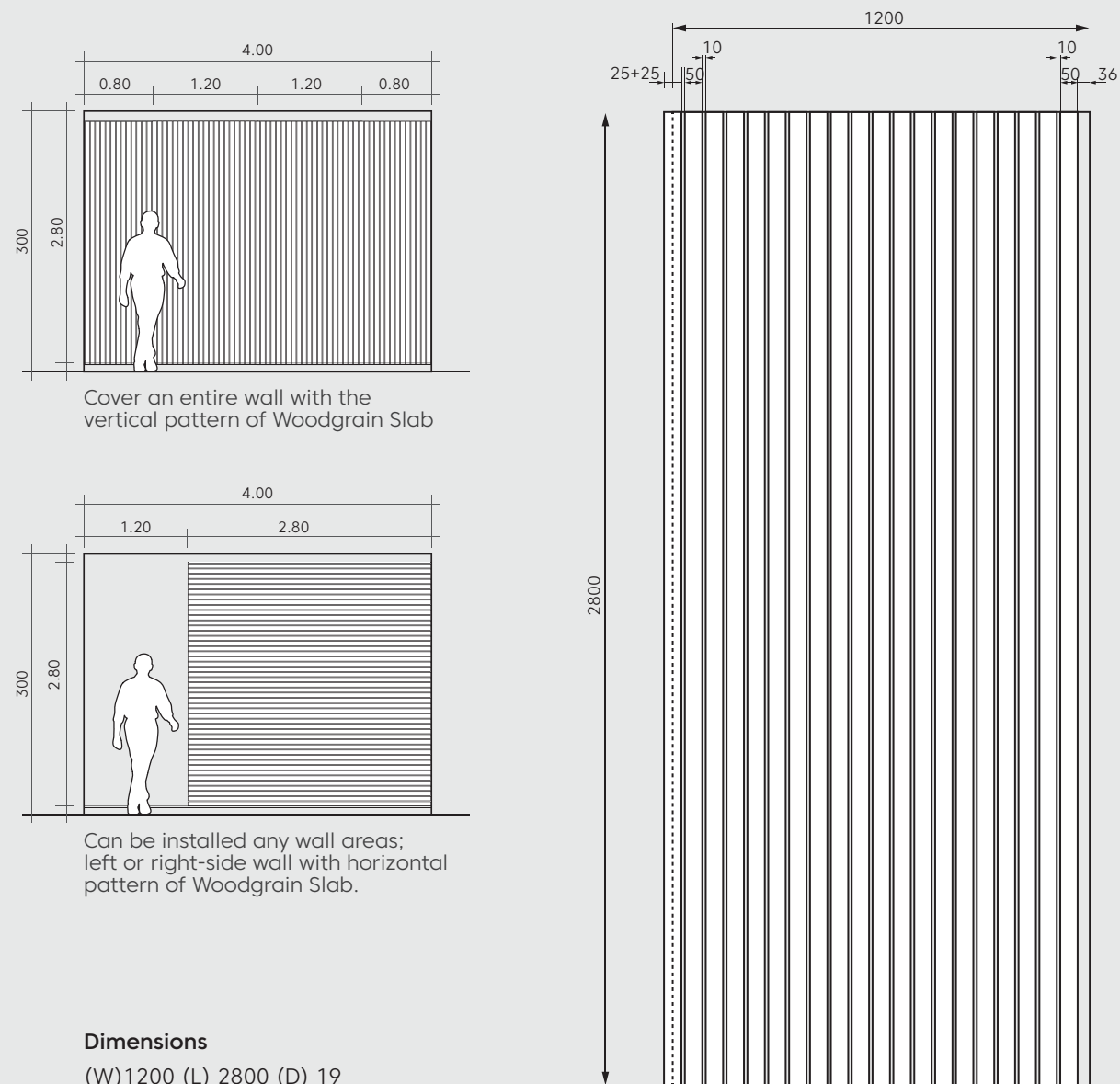

Cover an entire wall with the vertical pattern of Woodgrain Slab

Can be installed any wall areas; left or right-side wall with horizontal pattern of Woodgrain Slab.

**Dimensions**

(W)1200 (L) 2800 (D) 19

**Joint Detail**

Edge Lock

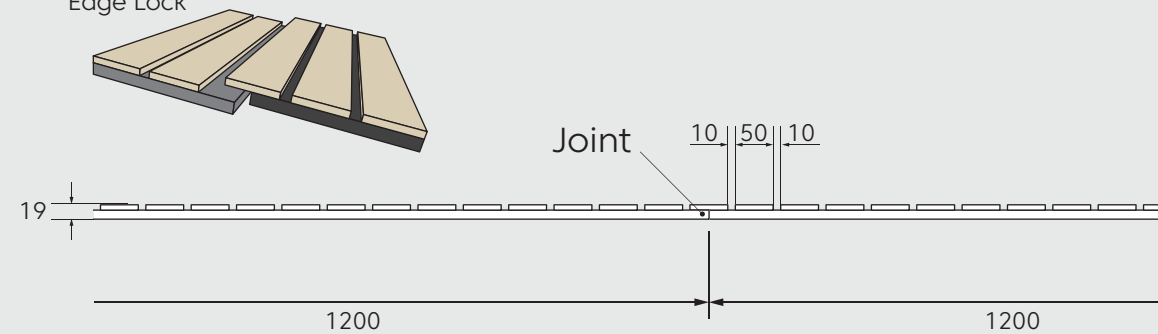

Natural Maple (WS 01)



America Walnut (WSP 05)



Walnut On Charcoal (WS 02)



Branwood Oak (WS 03)



Espresso On Charcoal (WS 04)



Charred Wood (WSP 06)