

FLOORGUARD®

SYSTEMS GUIDE



FLOORGUARD SYSTEMS GUIDE

Offering best-in-class performance and ultimate protection for concrete floors, the Colortek® range of epoxy coatings has been specifically developed to comply with the most demanding requirements, especially when it comes to durability, mechanical strength and chemical resistance.

Reducing the need for cyclical maintenance, whilst offering high standards in sustainability, the Colortek® epoxy range is ideal for demanding applications requiring total solutions.

www.colortek.eu



ToughGuard, Colortek, Wall & Floor Fashion and the Colortek Drop Symbol are registered trademarks.

© 2023



DESCRIPTION

3-pack, solvent-free epoxy filler and grout.

معجونة إبوكسي خالية من المذيبات ومكونة من ثلاث مركبات ذات متانة عالية. صممت لملء الفراغات وترميم الشروخ في الأسطح الخرسانية قبل استخدام أي صنف من اصناف النهي.

SPECIAL FEATURES

- Prevents ground moisture from surfacing
- Hygienic properties
- High strength
- No shrinking
- Waterproof
- Excellent chemical resistance
- Excellent impact and abrasion resistance

AREAS OF USE

Repairing and filling any imperfections and irregularities no matter their thickness in both walls and floors substrates before overcoating with epoxy systems.

TECHNICAL PROPERTIES

Property	Result	Standard
Solvent Type	Solvent free	
Joint width	2 to 20 mm	
Pot life	20 minutes	
Time to Traffic	24 hours	
Adhesion	> 4 N/mm ²	ASTM D4541
Tensile Strength	19.8 N/mm ²	ASTM C307-03
Flexural Strength	28.0 N/mm ²	ASTM C580-02
Water Absorption	0.01%	ASTM C-413
Bond to Concrete	30.0 MPa	ASTM C-882
Bond to Steel	26.0 MPa	ASTM C-882
Thermal Compatibility	Passes	
Density	Approx. 1.7 g/cm ³	
VOC	< 100 g/L	EPA Method 24

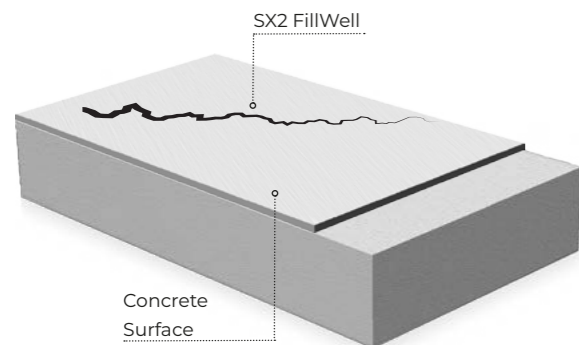

DESCRIPTION

2-pack, solvent-based, clear, epoxy primer designed to penetrate deeper into the concrete pores in order to achieve a better mechanical bond between the substrate and the epoxy coating.

دهان أساس إبوكسي شفاف، مكون من مركبين. صمم ليستخدم على الخرسانة والأسطح المسامية مما يضمن قوة التصاق وتماسك عالية قبل استخدام أي صنف من مجموعة الإبوكسي.

SPECIAL FEATURES

- Improves adhesion of epoxy coats to concrete
- Reduces bubbles and pinholes formation
- Allows epoxy base coat to achieve coating uniformity
- Penetrates and saturates the concrete surface pores
- Allows epoxy base coat to achieve a higher dry film thickness

AREAS OF USE

Sealing and saturating well-cleaned, properly prepared porous concrete surfaces to ensure the best possible adhesion and endurance of epoxy base coats.

TECHNICAL PROPERTIES

Property	Result	Standard
Solvent Type	Solvent based	
Dry Film Thickness	20-40 microns	ASTM D523
Spreading Rate	6-8 sqm/Kg	
Pot Life	180 minutes	
Adhesion	> 8 N/mm ²	ASTM D4541
Flexibility	No cracks at 1/8" conical mandrel	
Density	Approx. 1.0 g/cm ³	
Solids	Approx. 40% by volume	
Viscosity	0 – 500 cP (Spindle 2/ Speed 100)	
Color	Transparent	
VOC	635 g/L	EPA Method 24

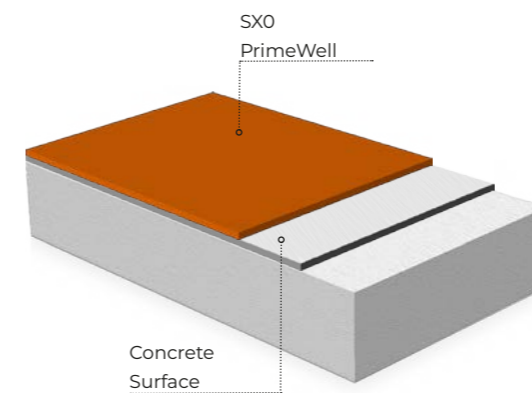



SX9 HUMIGUARD



SX1 TOUGHGUARD



EPOXY BROCHURE 7

EPOXY BROCHURE 8

DESCRIPTION

Moisture tolerant, 3-pack, solvent-free, epoxy primer suitable for high humidity areas or concrete that has not fully dried from being cleaned or acid etched.

دهان إيبوكسي شفاف خالي من المذيبات ومكون من ثلاث مركبات مقاومة للرطوبة. صمم ليستخدم على الخرسانة والأسطح المسامية مما يضمن قوة التصاق وتماسك عالية قبل استخدام أي صنف من مجموعة الإيبوكسي.

SPECIAL FEATURES

- Prevents ground moisture from surfacing
- Improves adhesion of epoxy coats to concrete
- Reduces bubbles and pinholes formation
- Allows epoxy base coat to achieve a higher dry film thickness
- Allows epoxy base coat to achieve coating uniformity

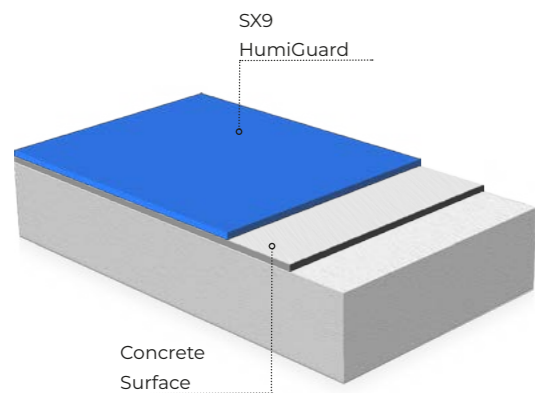

AREAS OF USE

Designed to act as a barrier against surfacing humidity and to seal porous concrete surfaces. SX9 HumiGuard ensures adhesion between the epoxy coat and the substrate.

TECHNICAL PROPERTIES

Property	Result	Standard
Solvent Type	Solvent free	
Dry Film Thickness	200 to 300 microns	ASTM D523
Spreading Rate	0.8 to 0.9 sqm/Kg	
Pot Life	30 minutes	
Adhesion	>9 N/mm ²	ASTM D4541
Flexural Strength	24 N/mm ²	ASTM C580-02
Density	Approx. 1.4 g/cm ³	
Solids	100% by volume	
Viscosity	0 – 500 cP (Spindle 2/ Speed 100)	
Color	Transparent	
VOC	< 5 g/L	EPA Method 24

DESCRIPTION

2-pack, solvent-based, general purpose epoxy used for industrial maintenance works and in light to medium traffic areas. Available in gloss and satin finishes. SX1 Gloss finish is smoother whereas SX1 Satin dries quicker and has an orange peel look.

دهان إيبوكسي مكون من مركبين وهو يصلح للإستخدام على الأرضيات. صمم لحماية الأرضيات والجدران الخرسانية في المناطق السكنية والأماكن العامة التي تتعرض لحركة مرور خفيفة أو متوسطة مثل مراكز التسوق. يستخدم أيضا على الحديد، البلاط و الأحواض في دورات المياه.

SPECIAL FEATURES

- Good abrasion resistance
- Good chemical resistance
- Optimum protection
- Resin rich
- Ideal to renovate tubs, tiles, blocked surfaces, etc.
- Ideal to renovate metal surfaces

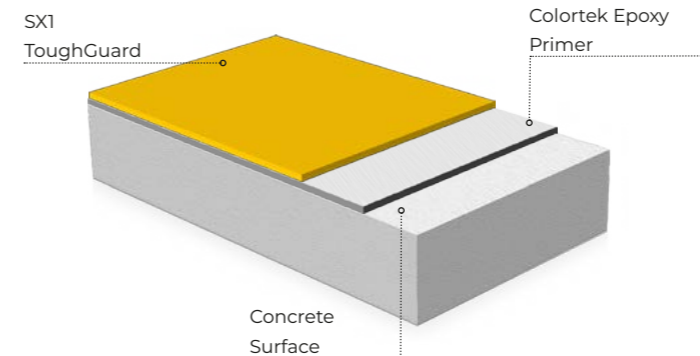

AREAS OF USE

Protection of concrete in light and medium traffic areas such as malls, hotels, villas and building garages. SX1 is also used as a top coat to renovate tubs and tiles on metal surfaces.

TECHNICAL PROPERTIES

Property	Result	Standard
Solvent Type	Solvent based	
Dry Film Thickness	75 microns	ASTM D523
Spreading Rate	6.5-7 sqm/Kg/Coat	
Pot Life	120 minutes	
Adhesion	> 4 N/mm ²	ASTM D4541
Abrasion Resistance	30 mg / 500 cycles	ASTM D4060
Impact Resistance	0.3 m/Kg	ASTM D2794
Density	1.25 g/cm ³	
Solids	Approx. 52% by volume	
VOC	400 g/L	EPA Method 24





SX5 WORXGUARD



DESCRIPTION

3-pack, high-build, solvent-free, self-leveling epoxy paint for medium to high traffic purposes.

دهان إبوكسي ذاتي التسوية مكون من ثلاث مركبات وهو خالي من المذيبات. يصلح للاستخدام على الأرضيات ذات حركة مرور متوسطة وثقيلة مثل مواقف السيارات والمستودعات والمصانع. إمكانية التنفيذ بالرول 0.00 ميكرون أو صب حتى 2.000 ميكرون / للوجه الواحد.

SPECIAL FEATURES

- Solvent-free
- Odor-free
- Self-leveling
- High-build
- Excellent chemical resistance
- Excellent abrasion and impact resistance

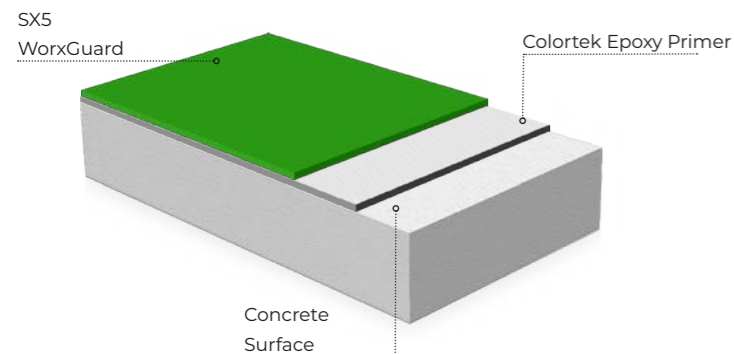

AREAS OF USE

Designed to protect concrete substrates in areas exposed to medium and high traffic such as warehouses, factories, research laboratories, car parks, etc.

TECHNICAL PROPERTIES

Property	Result	Standard
Solvent Type	Solvent free	
Dry Film Thickness	500 - 2000 microns	ASTM D523
Spreading Rate	1-1.3 sqm/Kg/coat at 500 microns roll applied 0.5-0.6 sqm/Kg at 1000 microns cast applied	
Pot Life	80 minutes	
Adhesion	> 4 N/mm ²	ASTM D4541
Abrasion Resistance	60 mg / 500 cycles	ASTM D4060
Impact Resistance	0.12 m/Kg	ASTM D2794
Density	1.5 g/cm ³	
Solids	100% by volume	
VOC	< 5 g/L	EPA Method 24



SX50 INDUSTRYGUARD



DESCRIPTION

3-pack, high-build, self-leveling, solvent-free epoxy coat for heavy traffic purpose.

دهان إبوكسي ذاتي التسوية مكون من ثلاث مركبات وهو خالي من المذيبات وذو قوة تحقل عالية. يستخدم في المناطق التي تزداد فيها حركة المرور مثل ممرات مواقف السيارات، المصانع، المخازن و حظائر الطائرات. يستخدم بسماكة من 2.000 ميكرون إلى 0.000 ميكرون / للوجه الواحد.

SPECIAL FEATURES

- Solvent-free
- Odor-free
- High solid content
- Self-leveling and high-build
- Excellent chemical, abrasion and impact resistance

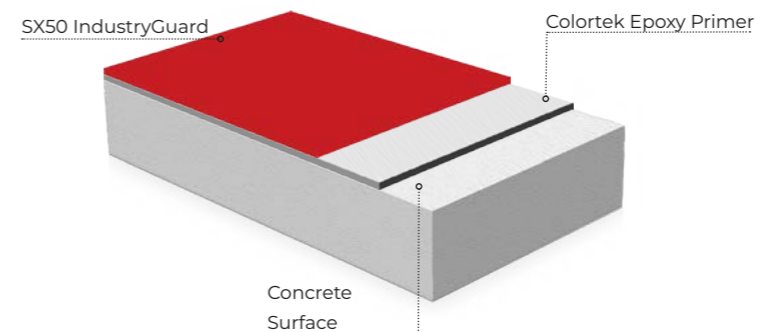

Concrete Surface



AREAS OF USE

Designed to protect concrete substrates in heavy-duty areas such as factories, warehousing, airport workshops and car parks with heavy traffic.

TECHNICAL PROPERTIES

Property	Result	Standard
Solvent Type	Solvent free	
Dry Film Thickness	2000 microns	ASTM D523
Spreading Rate	0.3 sqm./Kg at 2000 microns roll applied 0.6 sqm./Kg at 1000 microns cast applied	
Pot Life	30 minutes	
Adhesion	>3.54 N/mm ²	ASTM D4541
Abrasion Resistance	10 mg / 500 cycles	ASTM D4060
Impact Resistance	0.25m/Kg	ASTM D2794
Density	1.7 g/cm ³	
Solids	100% by volume	
VOC	< 5 g/L	EPA Method 24



SX90 STATICGUARD



DESCRIPTION

A three-component, solvent-free electrostatic discharge (ESD) epoxy paint for use in rooms containing volatile chemicals or sensitive electronic components.

دهان إيبوكسي بميزة التفريغ الكهربائي. مكون من ثلاث مركبات وهو خالي من المذيبات. يصلح للإستخدام في الغرف التي تحتوي على مواد كيميائية ضارة ومكونات إلكترونية حساسة.

SPECIAL FEATURES

- Precise ESD performance and protection
- Excellent impact, abrasion and chemical resistance
- Meets ANSI/ESD S20.20-2014 ESD Association Standard for the Development of an Electrostatic Discharge Control Program for Protection of Electrical and Electronic Parts, Assemblies and Equipment.

AREAS OF USE

Designed for controlling ignition risk in areas exposed to flammable solvents and vapors.

TECHNICAL PROPERTIES

Property	Result	Standard
Solvent Type	Solvent free	
Dry Film Thickness	500 - 2000 microns	ASTM D523
Spreading Rate	1-1.3 sqm/Kg/coat at 500 microns roll applied 0.5-0.6 sqm/Kg at 1000 microns cast applied	
Pot Life	80 minutes	
Adhesion	> 4 N/mm ²	ASTM D4541
Abrasion Resistance	60 mg / 500 cycles	ASTM D4060
Impact Resistance	0.12 m/Kg	ASTM D2794
Density	1.5 g/cm ³	
Solids	100% by volume	
VOC	< 5 g/L	EPA Method 24

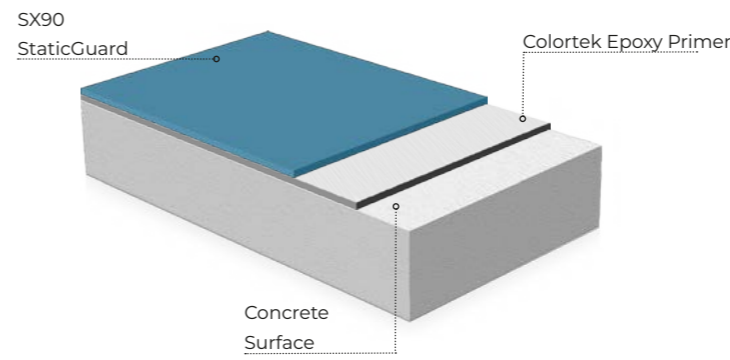



SX60 HEALTHGUARD



DESCRIPTION

3-pack, anti-microbial, self-leveling, high-build, solvent-free epoxy with enhanced hygienic properties.

دهان إبوكسي مكون من ثلاث مركبات خالية من المذيبات. يتمتع بخصائص صحية وقد صمم خصيصاً ليستخدم في مصانع الأدوية، المختبرات، المستشفيات والمطابخ الصناعية. إبتداءً من سماكة 0.00 ميكرون / للوجه الواحد.

SPECIAL FEATURES

- Inhibits microbial growth
- Odor-free
- Non-toxic
- Self-leveling and high-build
- Excellent chemical, abrasion and impact resistance

AREAS OF USE

Designed to protect floors where strict hygienic control is essential such as processing plants, pharmaceutical industries, laboratories, hospitals, industrial kitchens, and others.

TECHNICAL PROPERTIES

Property	Result	Standard
Solvent Type	Solvent free	
Dry Film Thickness	500 - 2000 microns	ASTM D523
Spreading Rate	1-1.3 sqm/Kg/coat at 500 microns roll applied 0.5-0.6 sqm/Kg at 1000 microns cast applied	
Pot Life	80 minutes	
Adhesion	> 4 N/mm ²	ASTM D4541
Abrasion Resistance	60 mg / 500 cycles	ASTM D4060
Impact Resistance	0.12 m/Kg	ASTM D2794
Density	1.5 g/cm ³	
Solids	100% by volume	
VOC	< 5 g/L	EPA Method 24

SX60 HealthGuard

Colortek Epoxy Primer

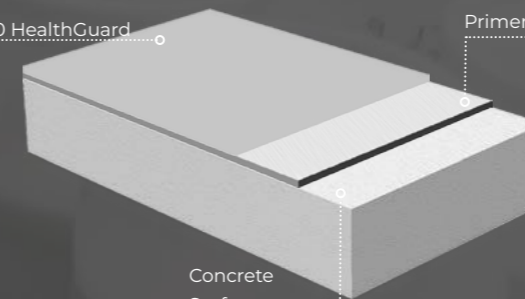

Concrete Surface





SX70 RAMPGUARD



DESCRIPTION

A 3-pack, high-build, solvent-free epoxy coat formulated with special viscosities and performance properties to ease application on ramps and inclined surfaces with an inclination of up to 20%.

دهان إيبوكسي ذاتي التسوية مكون من ثلاث مركبات وخالي من المذيبات. يصلح للاستخدام على الأرضيات ذات الحمولة المتوسطة. صمم خصيصاً للأسطح ذات إنحدار يصل إلى ٢٠٪ والأرضيات، الصانع، المستودعات ومواقف السيارات.

SPECIAL FEATURES

- Designed for inclined surfaces
- High-build
- Solvent-free
- Odor-free
- Excellent chemical resistance
- Excellent abrasion resistance
- Excellent impact resistance

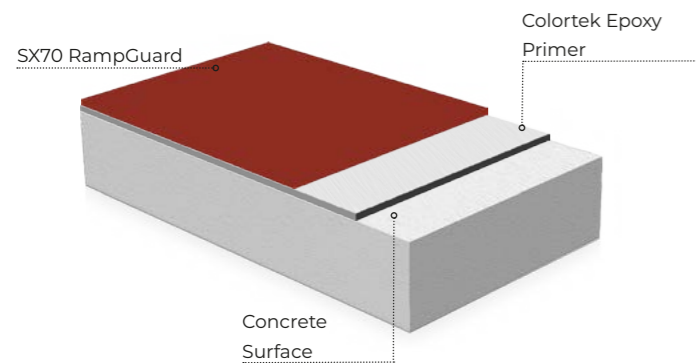

AREAS OF USE

Designed to protect concrete substrates in areas exposed to medium and high traffic such as car parks, warehouses, concrete loading ramps, and factories.

TECHNICAL PROPERTIES

Property	Result	Standard
Solvent Type	Solvent based	
Dry Film Thickness	500 - 1000 microns	ASTM D523
Spreading Rate	1.5 sqm/Kg at 500 microns roll applied	
Pot Life	30 minutes	
Adhesion	> 4 N/mm ²	ASTM D4541
Abrasion Resistance	10 mg / 500 cycles	ASTM D4060
Impact Resistance	0.15 m/Kg	ASTM D2794
Density	1.5 g/cm ³	
Solids	100% by volume	
VOC	400 g/L	EPA Method 24



SX80 SCREEDGUARD



DESCRIPTION

A 3-pack, extreme high-build, solvent-free epoxy screed designed to provide an impervious, hard-wearing, impact and mechanical resistant floor.

هو عبارة عن مونة إيبوكسي مكونة من ثلاث مركبات خالية من المذيبات. تستخدم لتسوية وترميم الأسطح الخرسانية والأرضيات كافة. تستعمل بسماكة من ٢٠٠٠ ميكرون إلى ٢٠٠٠٠ ميكرون / للوجه الواحد.

SPECIAL FEATURES

- Heavy duty dense surface
- Extreme high-build
- Solvent-free
- Outstanding mechanical properties
- Excellent chemical resistance
- Excellent abrasion resistance
- Excellent impact resistance

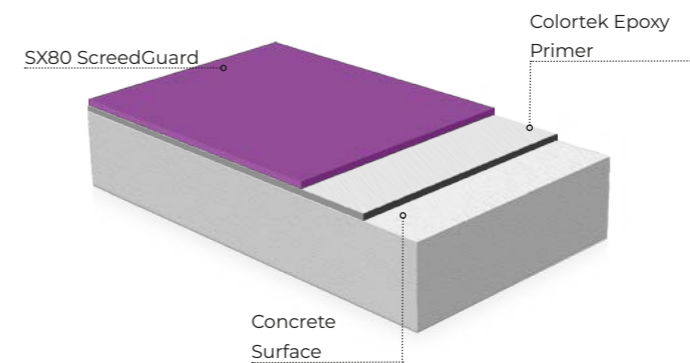

AREAS OF USE

Suitable for locations subject to extreme loads in almost every building environment including chemical process areas, steelworks, food and drink manufacturing areas.

TECHNICAL PROPERTIES

Property	Result	Standard
Solvent Type	Solvent free	
Dry Film Thickness	2000 - 20 000 microns	ASTM D523
Spreading Rate	0.09 sqm/Kg at 5000 microns cast applied	
Pot Life	20 minutes	
Adhesion	> 4 N/mm ²	ASTM D4541
Abrasion Resistance		ASTM D4060
Impact Resistance	0.6 m/Kg	ASTM D2794
Density	2.23 g/cm ³	
Solids	100% by volume	
VOC	< 5 g/L	EPA Method 24



FLOORGUARD COMPLEMENTARY ADDITIVES & TOP COATS

ANTI-SKID ADDITIVE

An additive that is broadcasted on the wet coat to attain a rough anti-skid texture.

مضاف مضاد للإنزلاق، صمم ليستخدم مع الإيبوكسي لضمان أسطح خشنة.

AVAILABLE WEIGHTS

- 0.750 Kg
- 25 Kg

AVAILABLE GRADES

- Super fine : 200-500
- Fine : 700-1200
- Coarse : 850-1700



LIGHT REFLECTIVE ADDITIVE

Highly transparent, light-reflecting beads that can be added to the wet surface, thus allowing for better visibility at night and in low light conditions.

مضاف مكون من حبيبات عاكسة للضوء. يستخدم مع الإيبوكسي لتأمين رؤية أفضل على الطرقات والمدرجات أثناء الليل.

AVAILABLE WEIGHTS

- 1.2 Kg





OXIBOND 4420 PU PROTECTIVE TOP COAT



DESCRIPTION

2-pack, UV-resistant, and friction-resistant polyurethane top coat used to provide ultimate protection to epoxy finishes against rubber tires and UV rays.

دهان بوليرتان يتألف من مركبين، مقاوم للأشعة البنفسجية. صمم لمقاومة الاحتكاك على الأسطح التي تتعرض لحركة مرور كثيفة كالمواقف والمستودعات.

SPECIAL FEATURES

- Flexible top coat
- Outstanding UV resistance
- Exceptional resistance to oil and grease
- Excellent abrasion and chemical resistance
- Dirt pick-up resistance

AREAS OF USE

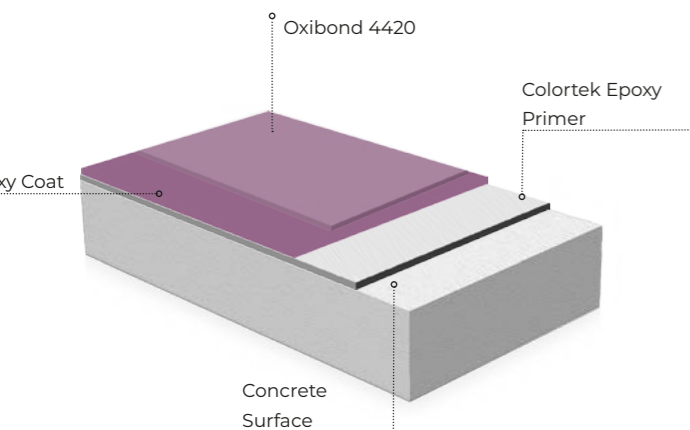

Designed to protect epoxy finishes from UV radiation and discoloration in areas exposed to sunlight and heavy abrasion, such as roof car parks, garages and warehouses.

TECHNICAL PROPERTIES

Property	Result	Standard
Solvent Type	Solvent based	
Dry Film Thickness	60 microns	ASTM D523
Spreading Rate Spray	5-7 sqm/Kg	
Pot Life	1 hour	
Adhesion	> 4 N/mm ²	ASTM D4541
Abrasion Resistance	70 mg / 500 cycles	ASTM D4060
Finish	Gloss	
Density	1.32 ±0.02 g/cm ³	
Solids	64% by volume	
VOC	355g/L	EPA Method 24



COLORTEK® TOUGHGUARD INDUSTRIAL COLORANTS & TINTING SYSTEM

21 ADDING COLOR TO EPOXY COATINGS

We offer our clients both high-volume manufacturing and point of service (POS) tinting technologies, allowing for unparalleled accuracy, repeatability and confidence that our customers are walking away with the exact color they selected, whether from our manufacturing facilities or from Colortek® Retail Centers.

Our POS colorants are also held to the same exacting scrutiny as the equipment we use to dispense them. Customers can be confident that colors comply with environmental regulations while still delivering superior performance and color consistency across all color systems offered by Colortek®: RAL, NCS, or our own COLORTEK SMARTMATCH Color Guides.

NOTICE

Custom colors can be ordered in Colortek® Design Centers through Colortek's ToughGuard industrial tinting system.

Please consult with your country's local authorized distributor or Colortek Franchise for availability.

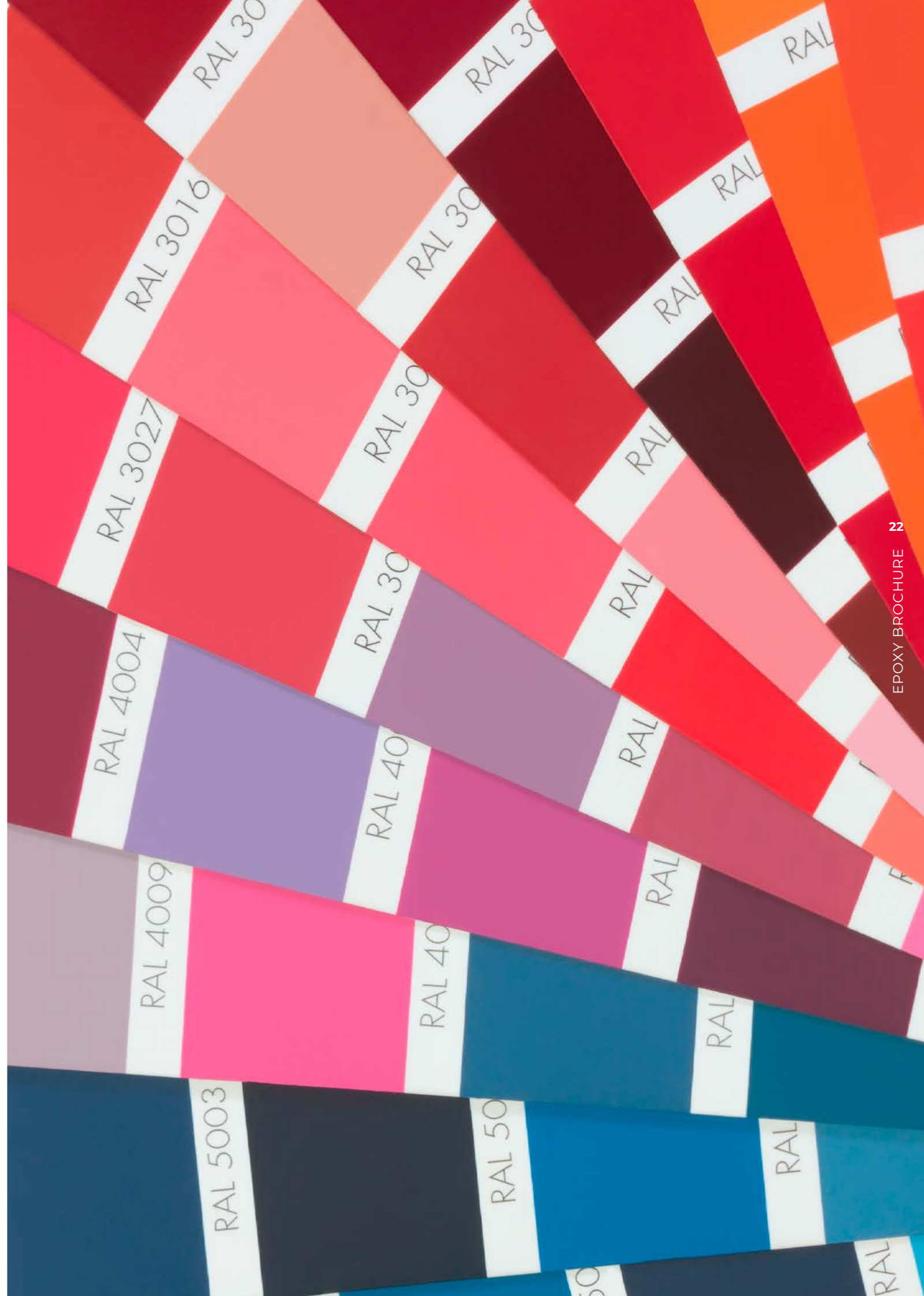

REPAIRING CONCRETE FOR GREAT RESULTS

CONCRETE SURFACES PREPARATION METHODS CONCRETE SURFACE PROFILES (CPS)

PRODUCT	DFT (Microns)	CSP-1	CSP-2	CSP-3	CSP-4	CSP-5
Sealer or primer	0 to 75	■				
Epoxy coating	100 to 300		■	■		
Epoxy self-leveling	1000 to 3000			■	■	
Screed	Above 3000			■	■	■

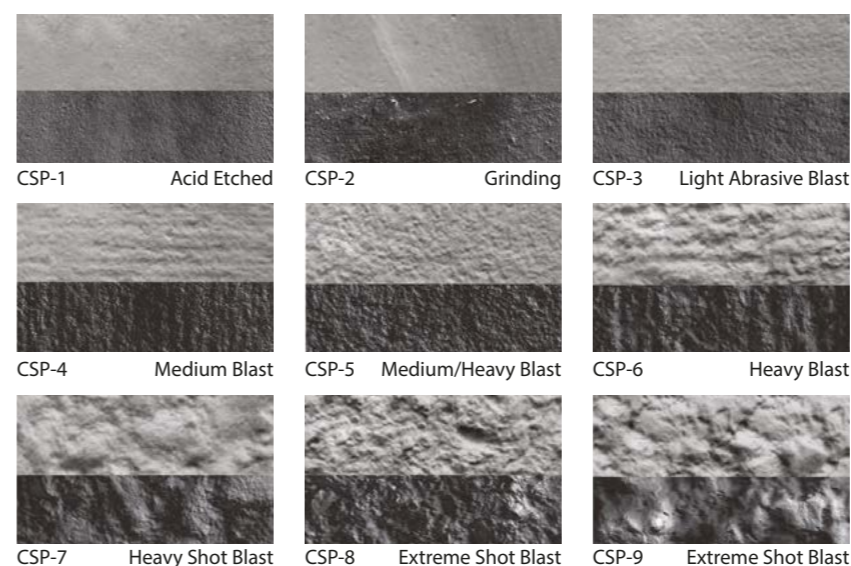

The CSP chart is used as a visual representation of desired concrete surface textures, roughness and general appearance. The guideline designates each CSP classification as a suitable base for specific coating types and thicknesses.

It also describes the method(s) or equipment typically used to achieve the texture according to the CSP classification.

Colortek® has been designed to comply with the most demanding requirements, especially when it comes to durability, mechanical properties and chemical resistance. However, Colortek's ultimate performance depends to a great extent on the correct preparation and conditioning of the surface to be treated.

This guide to surface preparation serves as a tool to select the method for preparing the concrete surface before application in order to secure the ultimate high-performance and adherence result.

Recommended surface preparation should follow the guidelines of the International Concrete Repair Institute (ICRI). Key to the guidelines is ICRI's Concrete Surface Profile (CSP) classifications, a system of distinct textures ranging from CSP1 (nearly flat) to CSP10 (extremely rough) used as a visual representation of desired concrete surface textures, roughness and general appearance.

The guideline designates each CSP classification as a suitable base for specific coating types and thicknesses. The Concrete Surface Profile (CSP) also describes the method(s) or equipment typically used to achieve the texture according to the CSP classification.

LAITANCE

Laitance is the weak, milky layer of cement and sand that rises to the concrete surface as a result of premature finish or troweling. If a coating is applied directly to the laitance layer, the floor traffic will cause disbanding of the coat.

CONTAMINATIONS

Old concrete floors can be contaminated by oil, grease, chemicals and others. Check the surface for dark patches that indicate contamination. Spray water on it to see if the surface absorbs it. If water stays on the surface, then it indicates contamination, and the stains must be removed by concrete cleaner or degreaser.

POROUS CONCRETE

The common procedure is to sand and apply a primer that penetrates the substrate well. In cases where a high performance is needed, it is possible to shot-blast the surface.

POLISHED CONCRETE AND NON-POROUS CONSTRUCTION MATERIALS

It is essential to apply proper primers. For high-performance systems such as those applied in hygienic areas, shot blasting, scarifying or grinding is necessary. It can be applied up to 3mm DFT depending on the specification.

WELL-ATTACHED OLD PAINT

Should be sanded in order to ensure good adhesion.

BADLY-ATTACHED OLD PAINT

Remains of badly-attached, old materials must be removed as these can cause detachment.

DAMP

Surfaces that have problems with dampness require water-borne systems that permit vapor permeability. If they don't comply with these requirements, there will be an increased risk that the flooring will blister or detach. For a coating to bond properly, the concrete surface must be sound, clean and free from surface defects and dryness. The surface should be properly roughened to establish a good mechanical bond.

ACID ETCHING PROFILE ACHIEVED

CSP-1

METHOD AND MACHINERY

Diluted hydrochloric acid is applied onto the floor to clean the surface.

NOTE

This method does not remove surface contaminants such as oil and grease, which must be removed before the etching process.



GRINDING PROFILE ACHIEVED

CSP-2

METHOD AND MACHINERY

A diamond grinder uses rotating discs to level, smooth and clean the concrete.

NOTE

Surface damage risk.



SHOTBLASTING PROFILE ACHIEVED

CSP-3 to CSP-7

METHOD AND MACHINERY

Steel particles are shot onto the surface, removing contaminants from the concrete.

NOTE

Surface damage risk.

