



HOSPITALITY
SOLUTIONS



simon

CONTENTS

INTRODUCTION 2

—	SIMON. <i>LIGHT UP EMOTIONS</i>	2
	GLOBAL SOLUTIONS	3
	LIVING THE SPACE	4
	ADAPTED FUNCTIONS	6
	ARCHITECTURAL INTEGRATION	12
	SIMON iO HOTEL. INTELLIGENT SPACES	16
	WELL-BEING	18
	PROJECT ACCOMPANIMENT	20

HOSPITALITY SPACES 22

—	RECEPTION / HALL	24
	BEDROOM / BATHROOM	30
	ROOM ACCESS	38
	BAR / RESTAURANT	40
	WORK SPACES	47
	SPA / GYM	52
	OUTDOOR AREAS AND PARKING	56

TECHNICAL INFORMATION 65

Emotions are what turn a space into a special place. Being able to fill it with nuances and different intensities is vital for us not only so that we can inhabit it but also so we can feel it, live it.

SIMON's solutions humanise technology and integrate with architecture to create unique spaces adapted to people's needs. And only in this way can we awaken their emotions.

Light up emotions.

Integrate global solutions into your projects, complementary combinations where lighting, connectivity or control of natural light, as well as USB charging or electric vehicle recharging functions, create "tailor-made suits" for each type of space.

Design and create the right atmosphere according to the context and the occasion by seeking environments characterised by sustainability, well-being, safety and comfort that influence our health and mood.

Global solutions.

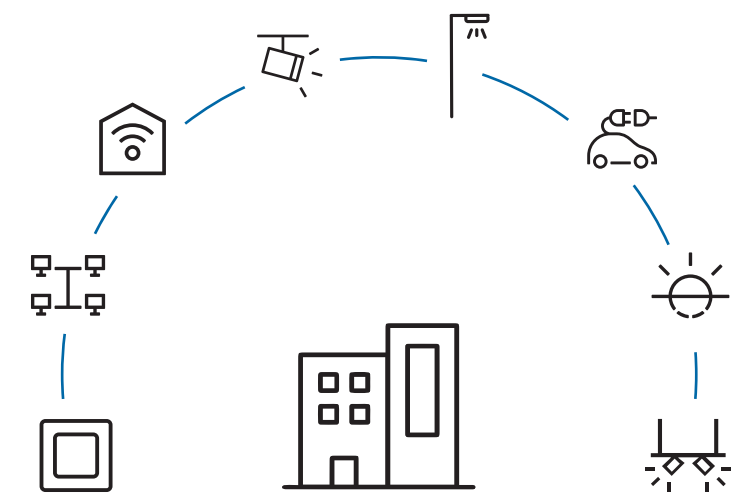



INTRODUCTION

Cosy environments that generate feelings of well-being in comfortable and connected spaces that are full of experiences to fill our lives with emotions.

Living the space.

Dimmer switches, thermostats, blinds controls,
USB charging solutions, multimedia connections,
experience keypads...

Together we can create flexible spaces where
the functions you need are seamlessly integrated
with the interior design.

Adapted functions.



INTRODUCTION

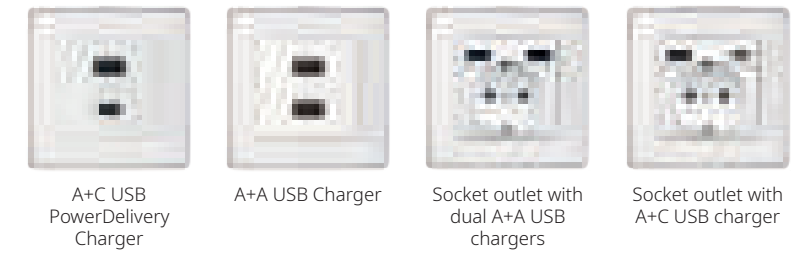
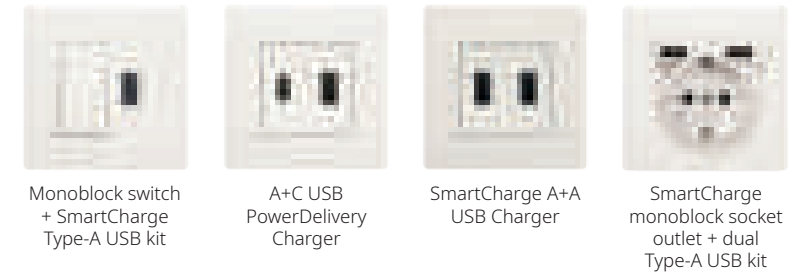
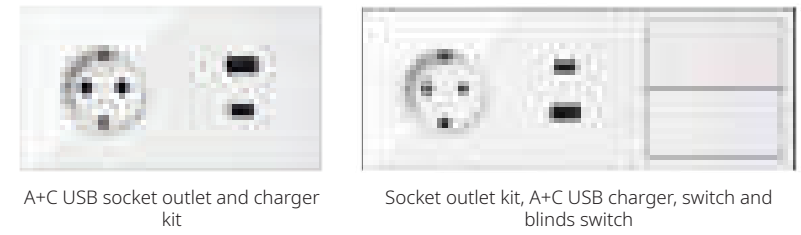
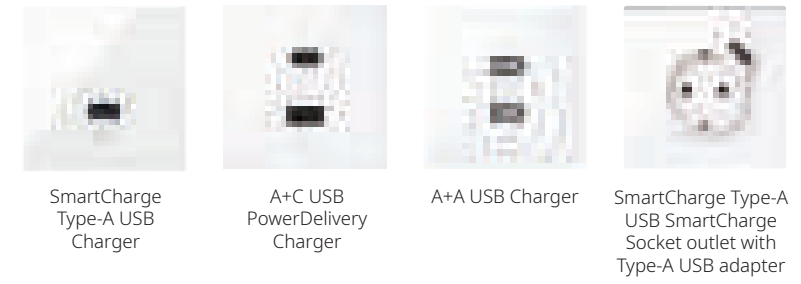
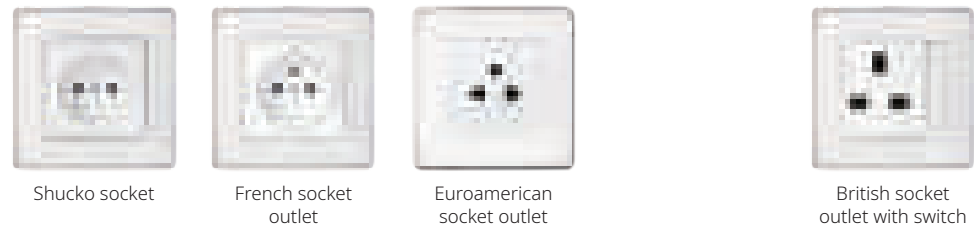

INTERNATIONAL FUNCTIONS



SmartCharge

USB charger that charges at the required amperage in the safest, fastest and most efficient way.

PowerDelivery

PowerDelivery is a fast-charging technology that reaches up to 30W, allowing you to go beyond charging mobile devices and small appliances to power even computers, monitors and laptops. It is compatible with certain Apple and Android devices.

* New Type-C USB PowerDelivery solutions coming soon.

USB* CHARGING SOLUTIONS

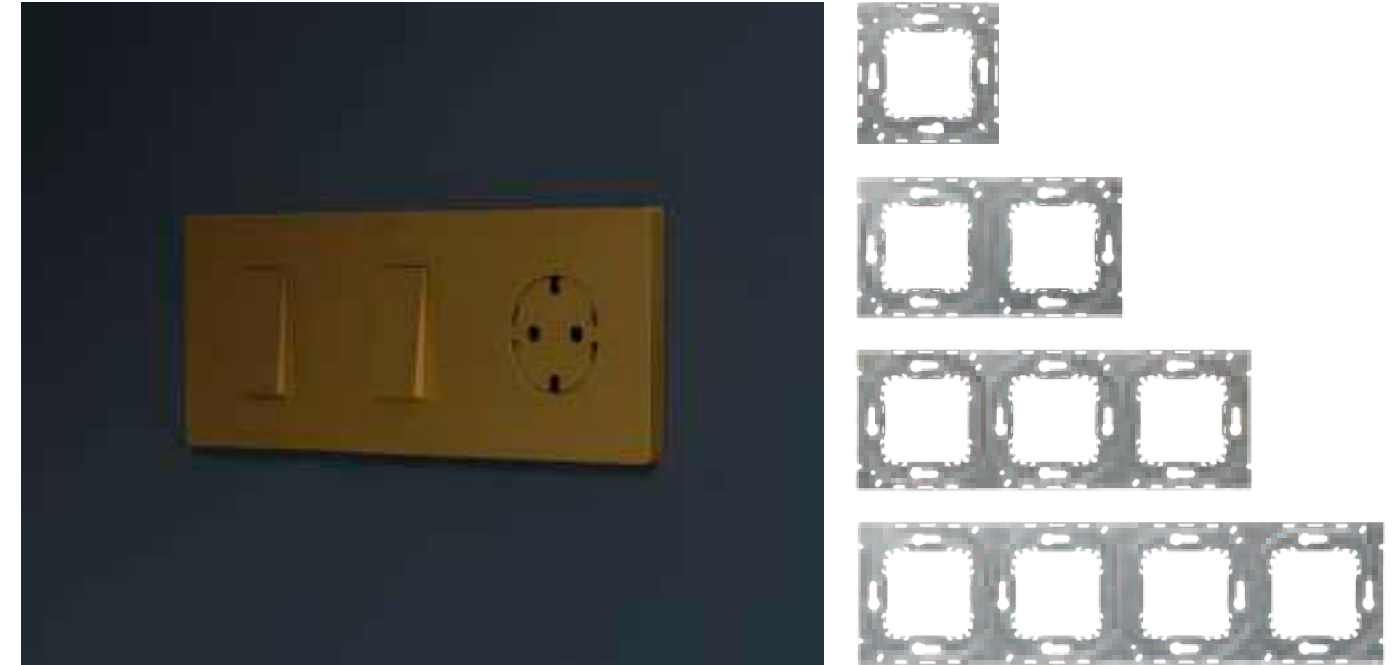

MULTIPLE FRAMES

Multiple metal frames ensure a perfectly aligned installation that guarantees safety and robustness. They feature precise, easy-to-install clip system and a rigid mounting plate for a perfect finish on the wall.

The elegance of the new CLEAN schuko Simon 270 lies in its simplicity. Its design goes beyond aesthetics and to improve people's quality of life. The CLEAN range has reinvented the traditional socket format, incorporating a flat surface that is flush with the wall to make it totally integrated and cleaner.

The cleanliness of the Simon 270 is as minimal as its design. Thanks to the **patented magnetic auto-cover system**, the cover automatically moves when the visible sockets are not in use to keep dirt from accumulating inside, making them easier to clean and extending their useful life.



CLEAN SCHUKO

CARD HOLDERS



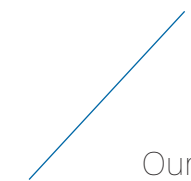
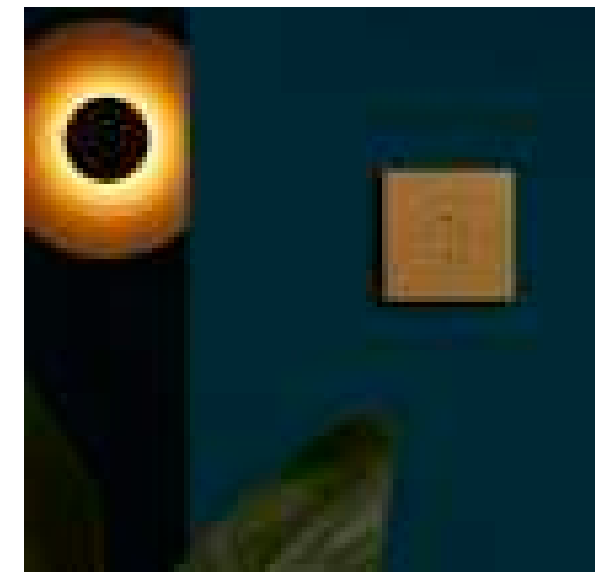
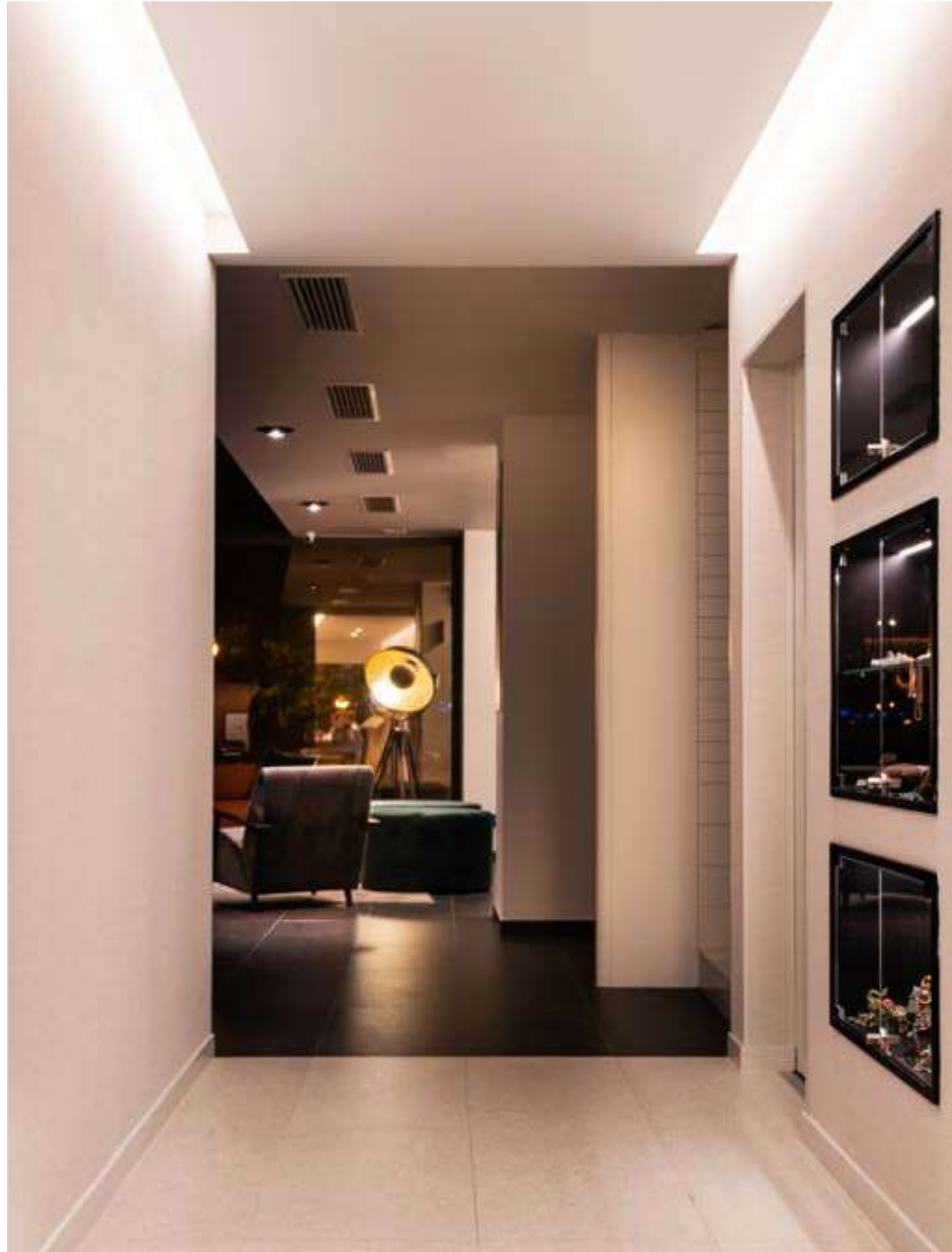

Our solutions are integrated into the architecture, furniture and all types of construction details, participating in the interior design and enhancing the attractiveness of work and leisure spaces.

Choose from a variety of lighting and decorative possibilities to find concepts that match the aesthetic and atmosphere of your projects.

Architectural
integration.

Simon_|100

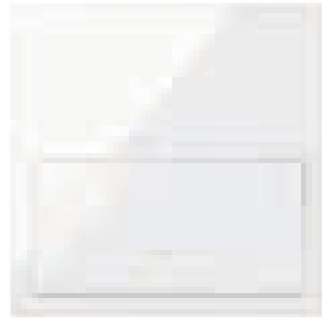

Gloss



Matte



Simon_|82
Concept



White

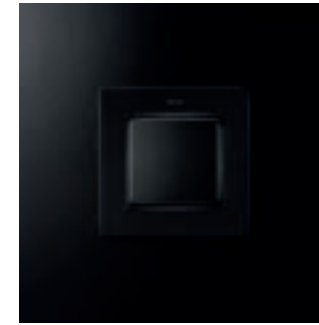

Black



Champagne

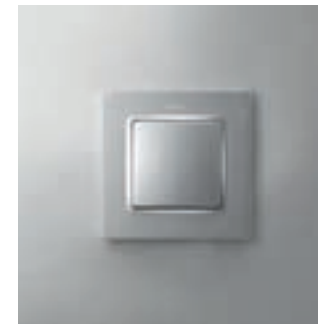

Aluminium



Titanium



Grey

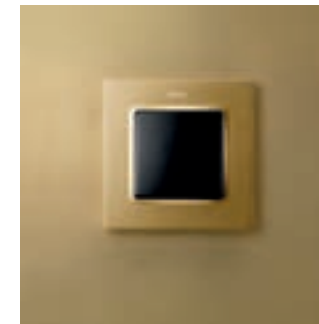

Gold

Simon_|270



White gloss / matte



Matte black



Titanium



Aluminium



Gold



Copper



Champagne

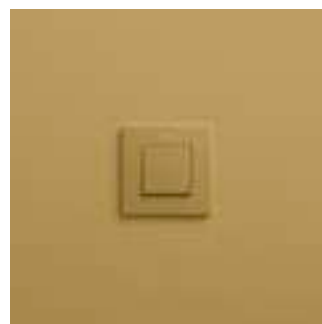

Bronze

Simon_|82*
Detail



White / Ivory / Aluminium / Graphite



White / Graphite / Aluminium / Wood

FINISHES

* See more finishes in Simon Tarifa.



Simon iO Hotel is Simon's solution for turning hotel spaces into intelligent spaces capable of offering guests maximum comfort with a very simple gesture and amplifying the architectural integration and global design trends.

This smart system offers control software via the building's own LAN structure to simplify maintenance and interfaces for climate control and the "do not disturb" function with the aesthetics of the Simon 270 series in eight different finishes.

Intelligent spaces.





The lighting of spaces not only causes changes in our emotions, it also affects our body, impacting our overall physical and psychological well-being.

People react to changes in the hue and intensity of light; its colour temperature is directly related to circadian rhythms: physical, mental and behavioural changes that follow the natural 24-hour cycle of sunlight.

Recreate the natural light cycle with solutions that improve mood, vision, productivity and health.

Well-being.





We collaborate with everyone involved in renovation and new construction projects, offering personalised advice to each professional at every stage of the process, from the creative and design phase to installation and commissioning.

Our sales team and projects department will accompany you so that you can make your ideas a reality and integrate all the solutions—mechanism series, iO ecosystem, indoor and outdoor lighting, control systems, connectivity and electric vehicle charging—by providing all the after-sales and technical assistance services you need.

Simon is made up of 4,000 people worldwide, and we are at your side in more than 90 countries with nine production facilities.

We accompany you.
Before, during and after
the project.



HOSPITALITY SPACES

- RECEPTION / HALL
- BEDROOM / BATHROOM
- ROOM ACCESS
- BAR / RESTAURANT
- WORK SPACES
- SPA / GYM
- OUTDOOR AREAS AND PARKING

RECEPTION / HALL



1
Simon Slim & Drop
Create personalised compositions adapted to the space, where light appears when it is needed.



2
Simon | 400 Individual sockets
Flush-mountable A+C USB socket outlets or A+C USB charging ports for office furniture.



3
Simon 500 Cima Floor
Kits configured with the most common combinations for each application, including high-speed voice and data, charging, power sockets, etc.

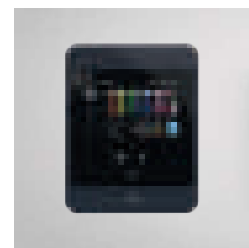

4
Simon Scena
So that you can control everything conveniently from a single point by centralising management of all actions.



5
Simon 810 Linear strip lighting
Light becomes a trace that forms part of the space, integrating itself into walls, ceilings, furniture and construction details.

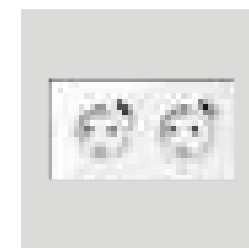

6
Simon 100 Socket outlet + USB kit
Power your devices in an agile way thanks to PowerDelivery and SmartCharge technology that will keep you connected at all times.

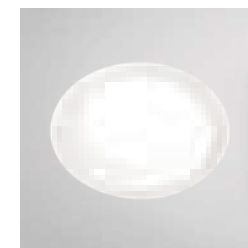

7
Simon 725 Downlight
They provide pleasant homogeneous general lighting. Their IP44 rating means that they are protected from the ambient dirt that can be generated in spaces like kitchens.



8
Simon Mood 25
Mood 25 provides subtle, diffused lighting that emanates from the translucent cylinder itself and is perfectly integrated into the lighted wall to show the way.

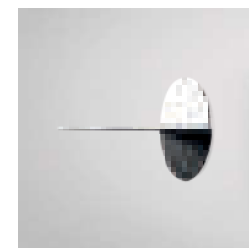

9
Simon Loop
Customisable configurations and assemblies that combine light and shadows, playing with the flow of light and 360° rotation of each independent element to create authentic work environments.



When it comes to lighting reception desks, visual comfort is important. That is why the structural modules of the **Simon Slim + Drop** allow 360° rotation with the possibility of directing the flow of light.

RECEPTION / HALL



Mechanism collection **SIMON 100** white gloss finish in convenient kit format with various functions that perfectly meet the needs of each room.

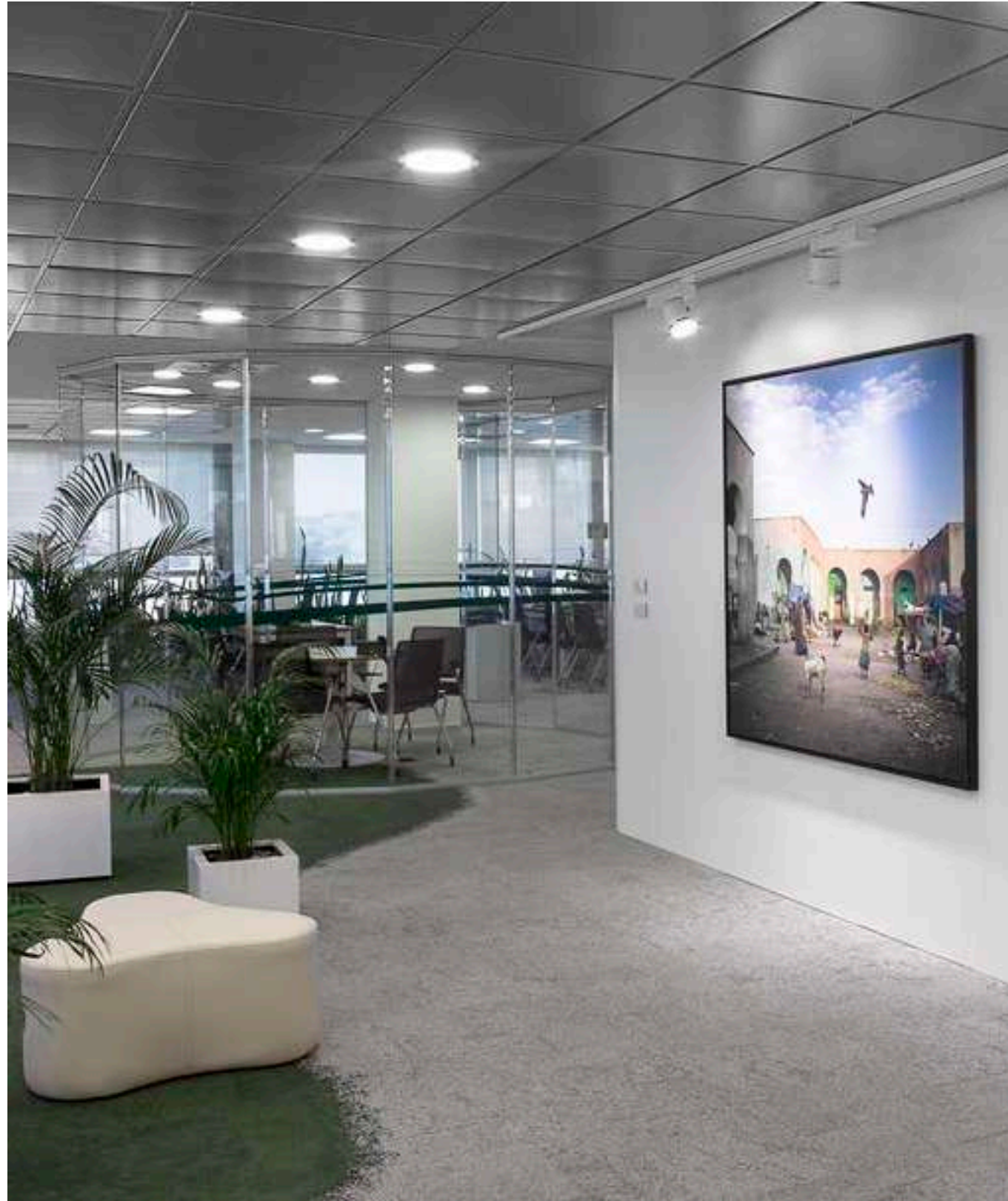

Simon 735 downlights for general lighting and Simon 640 spotlights for accent lighting on walls.

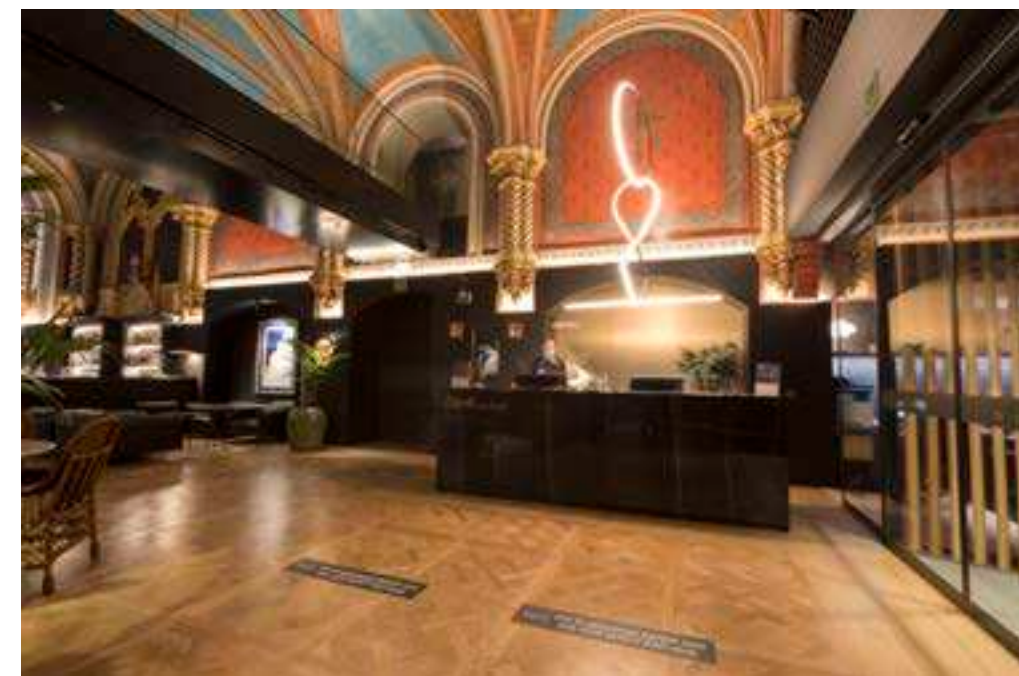

Simon 810 is Simon's linear LED strip lighting. It subtly emphasises forms and structures, creating spaces with volume and depth. It can be applied directly to the wall or integrated into furniture.



1
Simon 270 CLEAN
schuko socket

The CLEAN schuko series has reinvented the traditional socket format, incorporating a flat surface that is flush with the wall to make it fully integrated and cleaner.

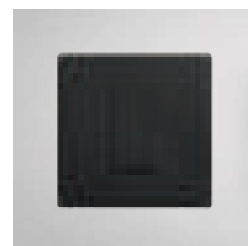

2
Simon 270 Míxima
Pushbutton switch

It turns on the light using a pushbutton that returns to its original position while maintaining a uniform aesthetic.

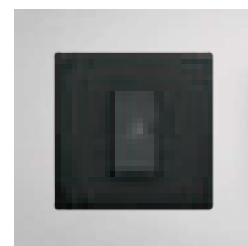

3
Simon 270 Míxima
3-position blinds switch

Raises, lowers and pauses motorised blinds and window shades with a minimalist aesthetic.

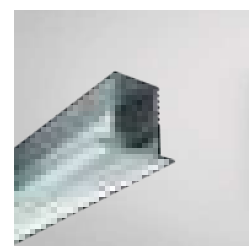

4
Simon 810 linear LED
strip lighting.
Mini profile

The mini profiles of the 810 Series are integrated into the perimeter of the mirror, creating a halo of diffused light that provides illumination.

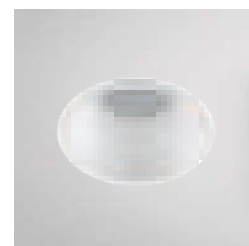

5
Simon 704 Downlight

Compact and minimalist in its aesthetic, the Simon 704 series is available in a variety of frames and optical versions for general or accent lighting.



6
Simon 400 Individual
sockets

Flush-mountable A+C USB socket outlets or A+C USB charging ports for office furniture.

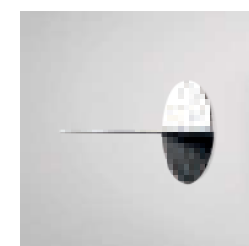

7
Simon Loop

Loop is integrated into the wall and rotates 360° on its axis to direct the light wherever you want it.



8
Simon Mood

Mood M1 incorporates a disc that can be painted the same colour as the wall, turning it into a beautiful circle of light that offers great compositional possibilities.



9
Simon Arch

Adjustable downlight suitable for general lighting or to highlight an area of the space.



10
Simon 810 linear LED
strip lighting. Slim
Profile

SLIM profiles are so thin that they are invisible even in surface installations directly on the furniture without the need for machining.

Simon 270 mechanisms available in eight finishes



white, black, titanium, aluminium, champagne, bronze, gold, copper

BEDROOM / BATHROOM

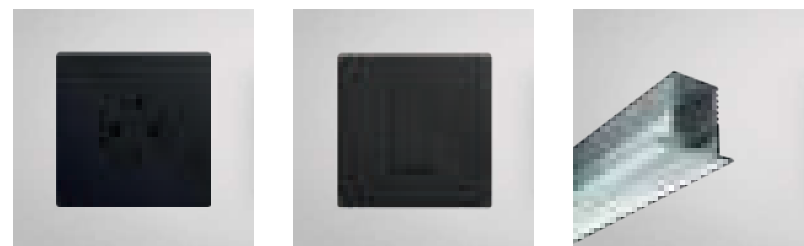

1 Simon 270 CLEAN schuko socket
2 Simon 270 Mínima pushbutton switch
3 Simon 810 linear LED strip lighting. Mini profile

Incorporating this function into the building automation system allows information on the status of each room to be shared in real time with the hotel's PMS, significantly improving the quality of service.

It turns on the light using a pushbutton that returns to its original position while maintaining a uniform aesthetic.

The mini profiles of the 810 Series are integrated into the perimeter of the mirror, creating a halo of diffused light that provides illumination.

Simon 270 mechanisms available in eight finishes



4 Composition for headboard Simon 270 Double push switch + dual USB A+C + CLEAN Schuko
5 Master Simon iO Hotel *Do Not Disturb* (interior room)
6 iO Hotel Simon 270 Thermostat Fancoil
7 Switch for Simon 270 card

The Headboard Kit brings together all the functions you need to have at the bedside. To enhance comfort and to let you operate lights and blinds and always have a USB charger or a power socket at hand.

Incorporating this function into the building automation system allows information on the status of each room to be shared in real time with the hotel's PMS, significantly improving the quality of service.

This intelligent mechanism allows easy climate control to ensure guest comfort with just two buttons.

It is an effective way of not leaving the lights, TV or hairdryer on when you are not in the room.



BEDROOM / BATHROOM

HOSPITALITY SPACES



Simon 100 kit with a dual socket outlet and USB SmartCharge.



Sense control system with customised functions tailored to the room, follows the **Simon 82 Detail** aesthetic of the rest of the room's mechanisms

Simon 270 CLEAN socket outlet for a wall-integrated aesthetic that is always clean. In a copper finish, one of the eight on-trend colours of this series of mechanisms.



Simon 810 is Simon's linear LED strip lighting. It subtly emphasises forms and structures, creating spaces with volume and depth. It can be applied directly to the wall or integrated into furniture.



BEDROOM / BATHROOM



Simon 100 kit in a matte white finish for bed headboard, socket outlet and USB charger, plus four pushbutton switches.



Simon 82 Concept in a single-colour finish to integrate with any environment. With socket outlet and dual USB charger.

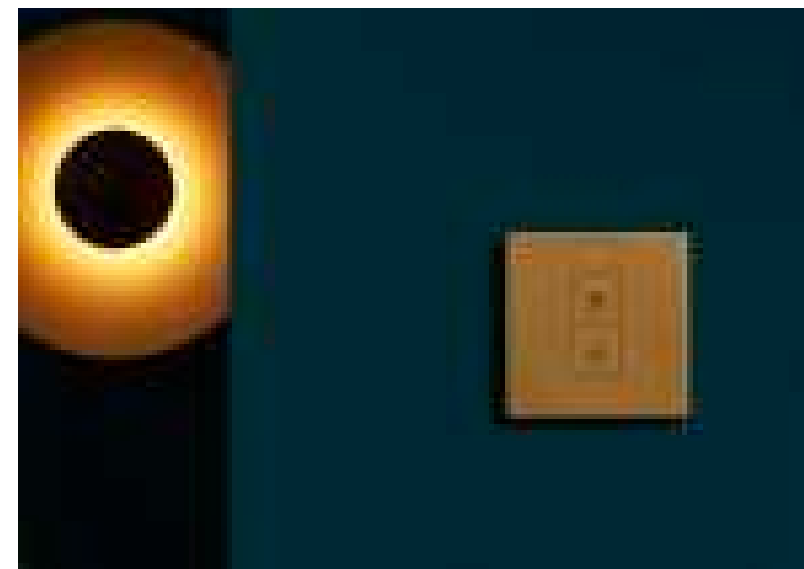

With the **Simon iO Hotel** master keypad you can give instructions to the cleaning service. "Do not disturb" or "Come in" in one click.

Simon | **iO**
Hotel



1
Simon iO Hotel *Do Not Disturb Indicator* (hallway)

Incorporating this function into the building automation system allows information on the status of each room to be shared in real time with the hotel's PMS.

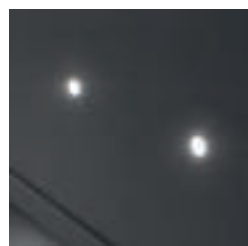

2
Simon Mood 25

The Mood 25 and Mood 110 versions provide subtle, diffused lighting that emanates from the translucent cylinder itself and is perfectly integrated into the lighted wall to show the way.

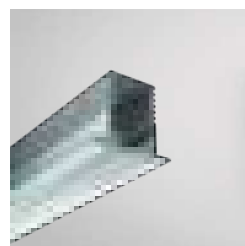

3
Simon 810 linear LED strip lighting. Slim profile

SLIM profiles are so thin that they are invisible even in surface installations directly on the furniture without the need for machining.

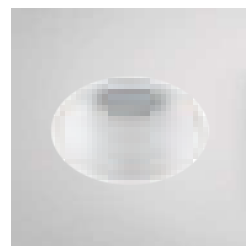

4
Simon 703 / 704 Downlight

Comfortable ceiling light suitable for installation in wet areas and close to showers and bathtubs thanks to its IP44 waterproof rating.

HALLWAY



Simon 810 is Simon's linear LED strip lighting that's perfect for indirect lighting and showing the way in a hallway. Simon 82 Detail socket outlets with metal detailing to integrate with any décor

The Simon Scena lighting control system allows you to create RGB lighting scenes to achieve unique atmospheres in each space via a console.



Simon's solutions accompany any type of hotel experience, including get-togethers for drinking, eating or unwinding. From mechanism collections with USB solutions for charging a cell phone during a meal to lighting systems to create the right atmosphere for any occasion. Everything necessary to ensure comfort in bar or restaurant settings.

Bar / Restaurant.





Simon 810 is Simon's linear LED strip lighting. It subtly emphasises forms and structures, creating spaces with volume and depth. It can be applied directly to the wall or integrated into furniture.

BAR / RESTAURANT



The **Simon Scena** lighting control system allows you to create RGB lighting scenes to achieve unique atmospheres in each space via a console.



Simon 810 is Simon's linear LED strip lighting. It subtly emphasises forms and structures, creating spaces with volume and depth. It can be applied directly to the wall or integrated into furniture.



703 DOWNLIGHTS with a thermal dissipation system that enables better elimination of the heat from the LED, prolonging its useful life.



BAR / RESTAURANT



ARCH DOWNLIGHTS can be used for both general and accent lighting. Their design and lighting possibilities facilitate the creation of different atmospheres and sensations depending on whether it's a restaurant by day or an intimate beach club by night.





Our solutions are adapted to new needs that arise in the changing conception of workspaces. Healthy environments that are not only functional but also wholesome and stimulating, and that provide the flexibility and comfort needed in today's *workplaces* .

Working spaces.

The **Slim System** allows you to create custom configurations with an infinite number of possibilities that are fully adapted to the space. Hanging or recessed structures that provide illumination in a linear and minimalist way.



The combination of luminaires that are equal parts functional and decorative, such as **Simon Loop**, brings warmth that transforms any working environment into a stylish and comfortable space.



Recessed luminaires can provide accent or general lighting, allowing spaces to be categorised.



Simon 400 is integrated into the desktop, taking up as little space as possible to maximise the usable work surface.



Simon 500 Cima wall boxes. Clean surfaces that keep the workspace clear so that nothing can stop you from creating.

In today's context, the flexibility of individual work areas is becoming increasingly important and generates new requirements. The **Simon Slim System** makes it possible to retrofit spaces to meet the needs of the new ways of working in this paradigm shift.



Hanging luminaires can provide accent or general lighting, allowing spaces to be categorised.

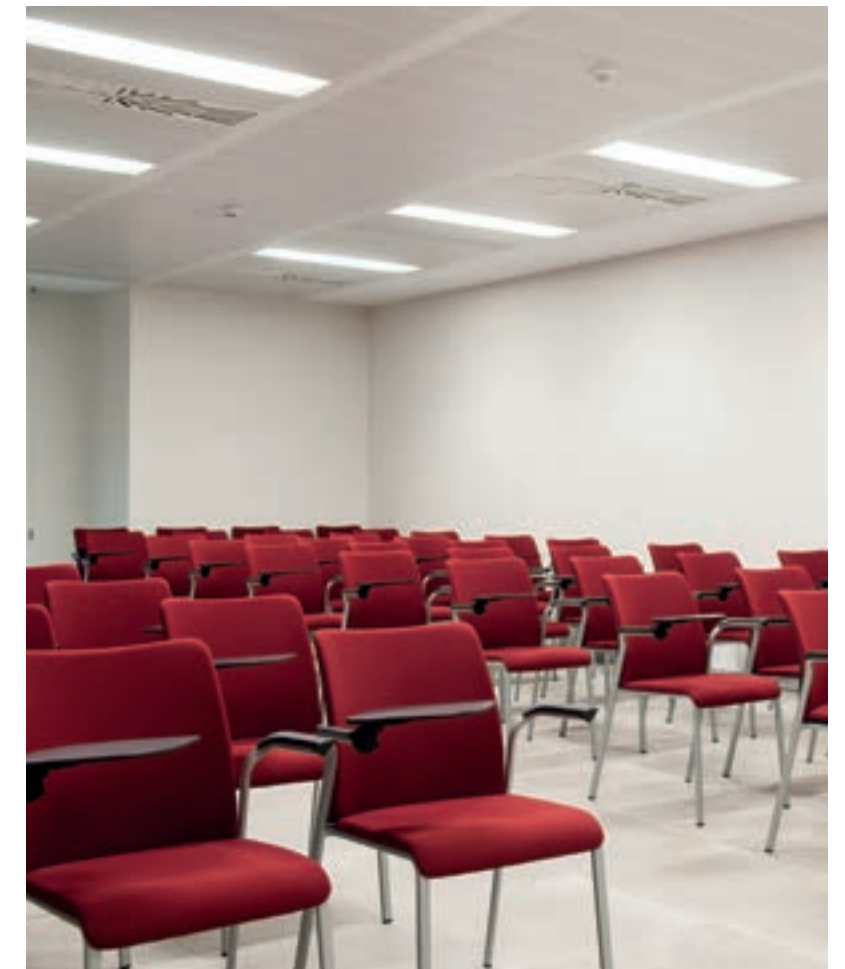

With dynamic light, our solutions enable you to synchronise artificial light with the natural light cycle, thereby humanising interior spaces and adapting them to people's needs.



Time to unwind. Emotions are made palpable through light. The different controls allow you to play with the intensity, tonality and the different nuances of the light to modulate the mood of the customers.

Spa / Gym

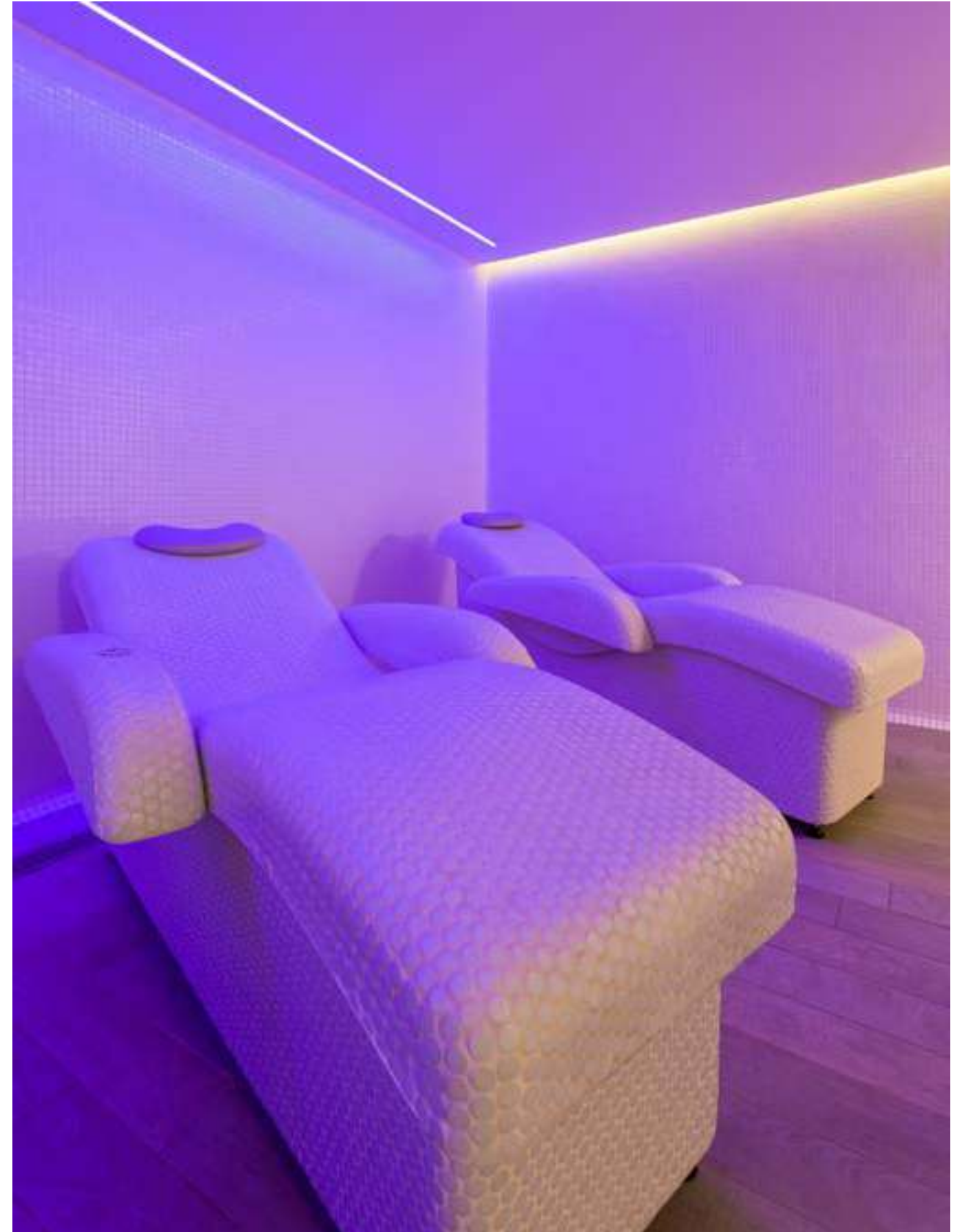



RGB LINEAR LIGHTING recessed with diffuser and surface-mounted in a recessed area. The SCENA control system allows you to adjust the colour and temperature from 2700K to 6000K and to adapt it to create an atmosphere of well-being and relaxation



Simon K45 watertight floor box with IP66 moisture protection for socket outlets.





A hotel's outdoor spaces are just as important as its indoor ones. So Simon's solutions extend to terraces, gardens, driveways and even car parks. Products designed for harsh environments and hold up over time whilst preserving the essence of design and architectural integration.

Outdoor areas and parking.





Skat is a well-designed luminaire with sleek and attractive lines. A minimalist aesthetic and different optical versions facilitate their integration into different outdoor areas where comfortable and efficient lighting is needed.



The Simon 44 Aqua collection was created for environments with water and dust and for outdoor areas. Its broad versatility and range of functions adapt to any challenge and, as always, do it with elegance.

Install strategically placed sockets in your garden or terrace. Mechanisms that are resistant to weather, water, dust and impacts, such as the Simon K45 waterproof box, a perfectly integrated floor solution. With an IP66 protection rating.



Impact-resistant and tamper-proof, the Simon 27 Scudo collection was made for harsh environments. Compatible with all mechanisms in the Simon 27 collection.



Simon Neon electric vehicle charging points are perfect for outdoor environments. Made of stainless steel, they are strong and robust, and their indicator light shows the charging status.



Simon 780 waterproof for lighting car parks.



Simon is committed to sustainability with electric vehicle charging points, focusing on electric mobility to contribute to the goal of a cleaner future. Simon SM20 Business is the perfect solution for charging electric vehicles at hotels, shopping centres, company car parks and offices.



The waterproof profiles of the **810 Series** blend in subtly with any building element, creating trails of light that illuminate pass-through zones, walls, stairways and landscaped areas.

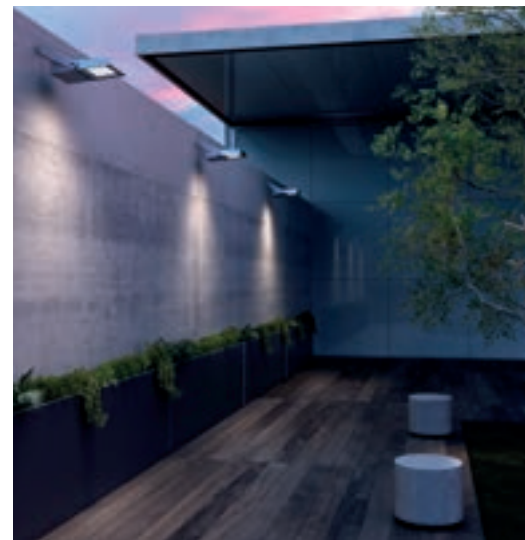

Outdoor luminaires such as Iraya to contribute to the safety, sustainability and functionality required in every environment in both public and private spaces.



Simon Hera is a range of beacons for illuminating private and public spaces. With a choice of one or two heads depending on the project and a choice of three different heights.

DIGITALISATION OF LIGHTING AND CREATION OF LIGHT-BASED EXPERIENCES

ProtoPixel

ProtoPixel is Simon's technology partner for digitalising lighting and creating innovative light-based experiences. With this partnership, Simon is taking a step forward in combining dynamic, connective lighting with the user experience.



PROTOPIXEL

TRANSFORMING LIGHT INTO INDIVIDUALISED EXPERIENCES

ProtoPixel Create is the lighting design software for all types of creatives. From designers new to lighting to experts creating high-impact light-based experiences. It contains a library of content that is ready to use in luminaires.



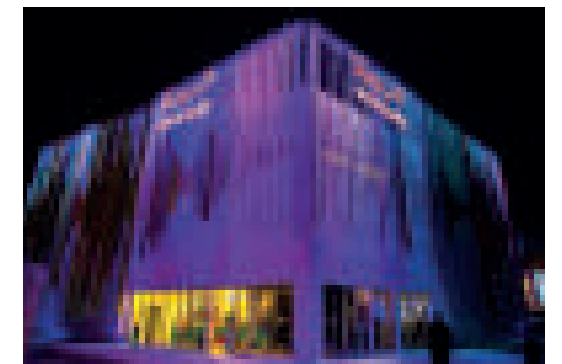
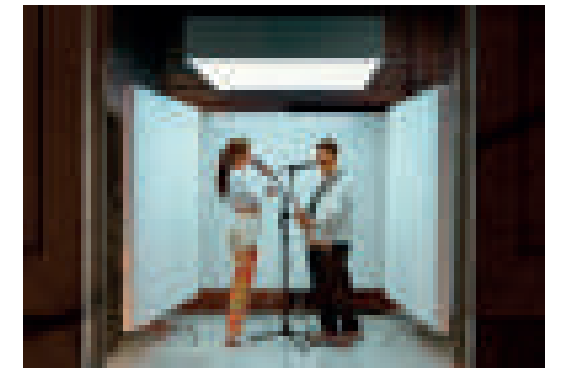

A simple, versatile and limitless ecosystem that makes dynamic lighting control simple, accessible and efficient. And with a consistent user experience, from the designer to the consumer.



INTEGRATION

The platform can be fully integrated both in conceptualisation of the content—by adding photos, videos, text, sound, sensors, etc.—and in the control of dynamic and digital lighting: white, tunable or colours: W, RGB, RGBW and WWA. Compatible with the most widely used lighting protocols such as Artnet, DMX, DALI, Zwave. And ultimately capable of integration with local control elements that are part of the space.

TECHNICAL INFORMATION

- ACTUATOR 
- THERMOSTAT 
- DO NOT DISTURB* - MASTER AND INDICATOR 
- CARD HOLDERS
- USB CHARGING SOLUTIONS
- ELECTRIC VEHICLE RECHARGING
- SIMON 703 / 704 DOWNLIGHTS

TECHNICAL INFORMATION

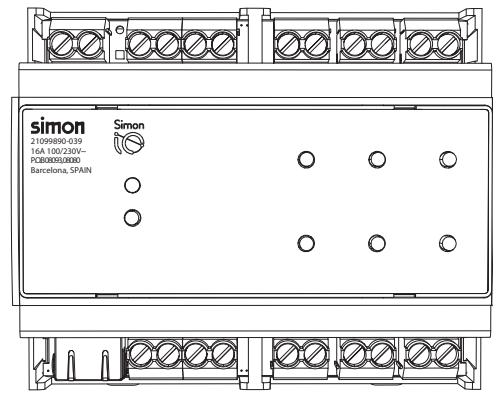

21099890-039

Technical Specifications

100-230V~ 50/60Hz	40°C 0°C	90% HR	802.11 b/g/n	INDICATORS 1 LED RGB	Ethernet port
IP20	16A	DIGITAL INPUTS 6	OUTPUTS 6	DIMENSIONS 107x90x65 mm	ZERO CROSSING
CE	WEEE				

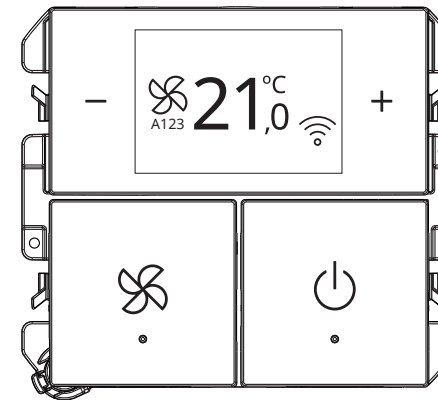

21099811-09x

Technical Specifications

127-230V~ 10A	40°C 0°C	90% HR	802.11 b/g/n	INDICATORS 2 RGB LEDs	OLED Display	IP20
CE	WEEE					

⚠ The IO actuator must always be connected after a miniature circuit breaker (MCB). It is installed on a DIN rail.

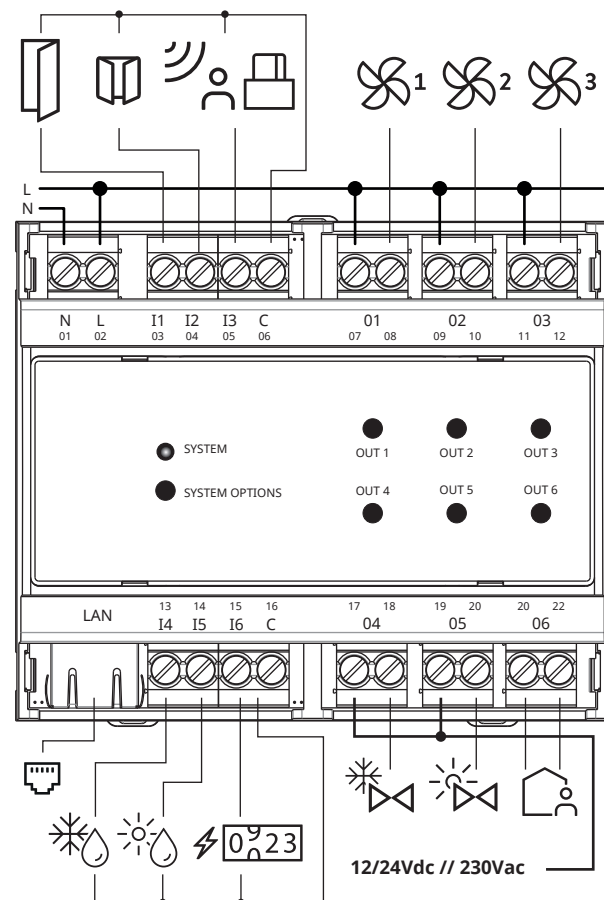

- Door contact sensor
- Window contact sensor
- Presence detector or card holder
- Fan power controller
- Ethernet port
- Electricity meter
- Cold-water meter
- Hot-water meter
- Cold-air valve
- Hot-air valve
- Occupation contact

INSTALLATION

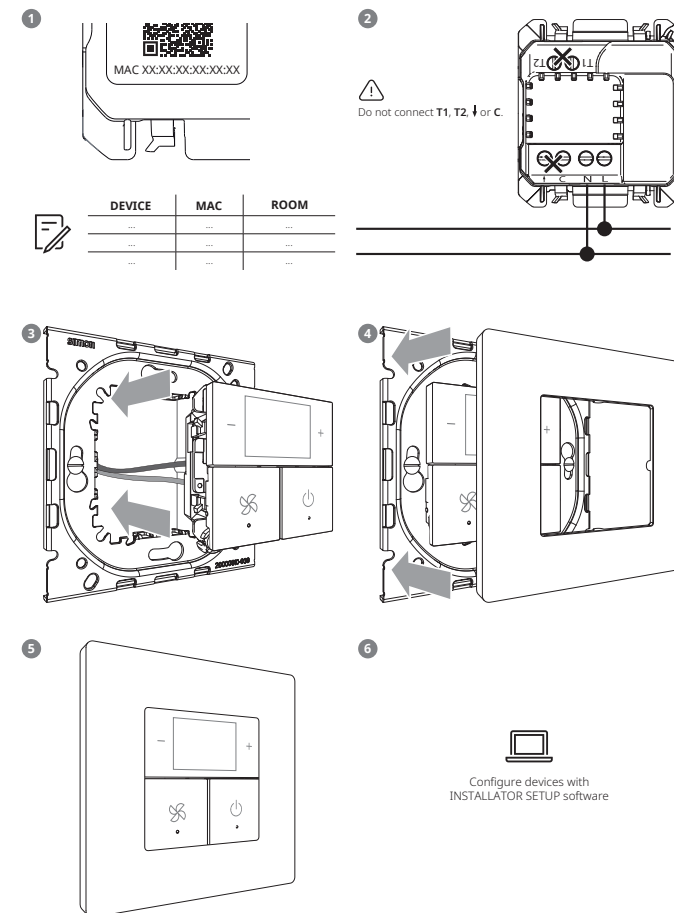

DISPLAY AND USE

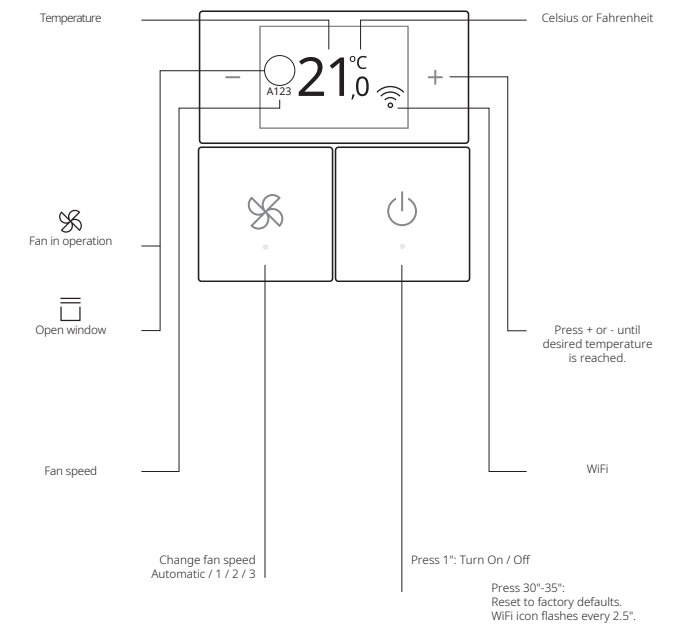

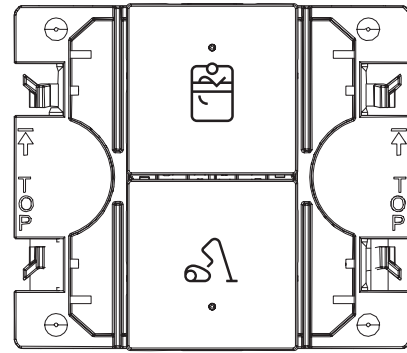

MASTER (room) 21099035-09x

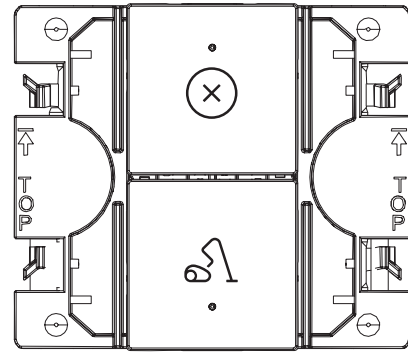

Indicator (hallway) 21099036-09x

Technical Specifications

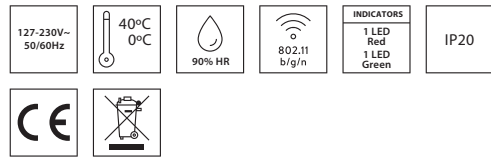

INSTALLATION

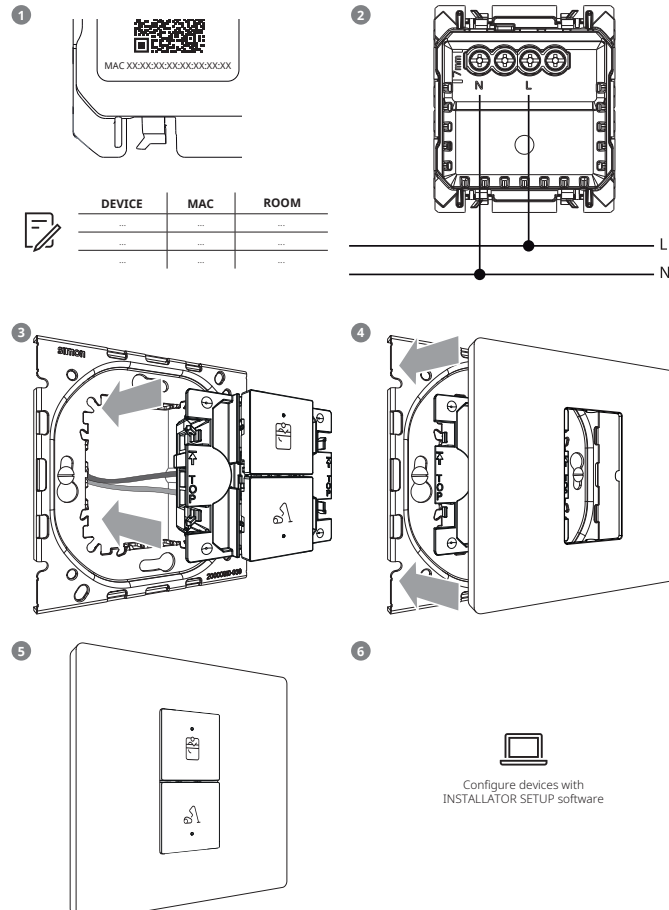

DISPLAY AND USE

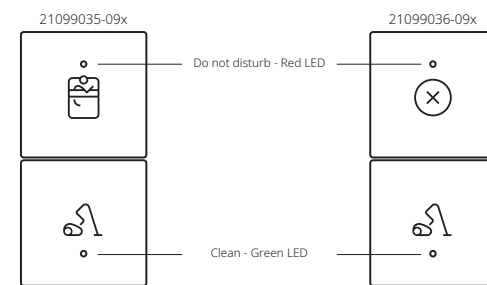

EVENT	BUTTON ACTION	DEVICE STATUS	LED RESPONSE	DEVICE PERFORMANCE
	Not pressed	Not linked in Simon IO App Error	Bottom LED flashes for 1 sec Bottom LED flashes for 0.1 sec	
Press Do Not Disturb key (master device)	Short pulse (t<2s)	No mode selected	Top LED lights up in red (master/indicator)	Do Not Disturb action is reported
		Clean Room mode activated	Top LED lights up in red (master/indicator) and bottom LED goes out	Do Not Disturb action is reported
Press the Clean Room button (master device)	Short pulse (t<2s)	No mode selected	Bottom LED lights up in green (master/indicator)	Clean room action is reported
		Do Not Disturb mode activated	Bottom LED lights up in green (master/indicator) and top LED goes out	Clean room action is reported
Reset to factory defaults	Long press (t>30s)		Bottom LED lights up for 2.5 sec	Factory reset

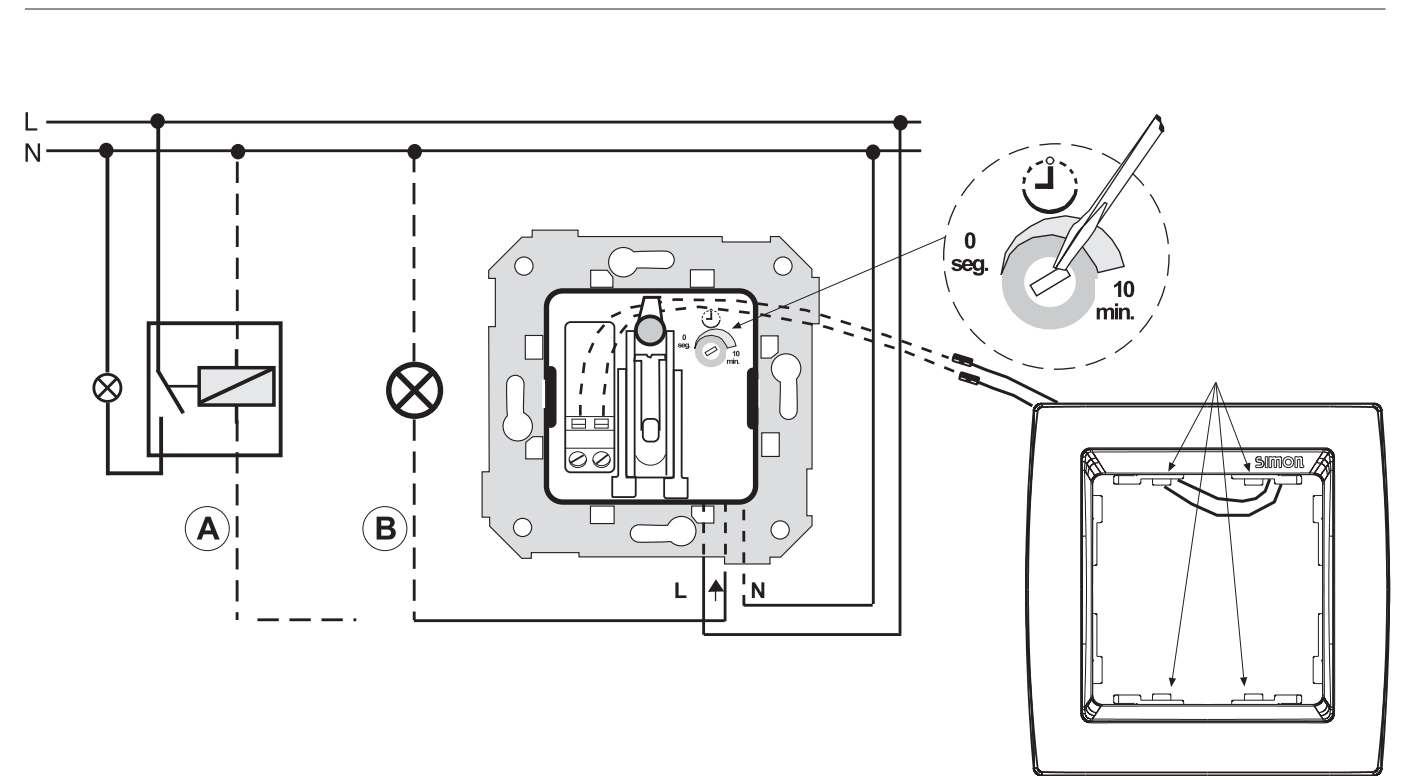

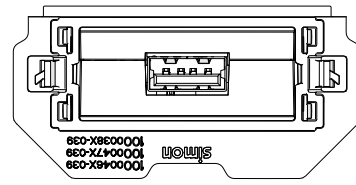

10000380-039

Technical Specifications

127 VAC 60Hz (±10%)	230 VAC 60Hz (±10%)	Standby <100mW	5V 2,1A Max.
35°C 5°C	IP20	CE	
EAC			

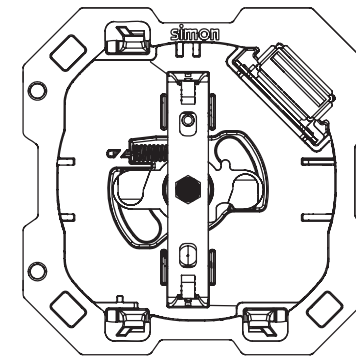

SCHUKO SOCKET
10001432-039

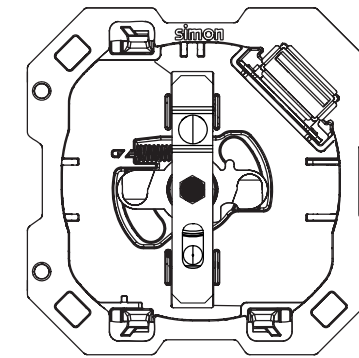

FRENCH SOCKET
10001458-039

Technical Specifications

230V~ 50Hz (±10%)	16A / 250V~	35°C 0°C	90% HR	IP20
5V 2,1A Max.	Standby <100mW	CE		

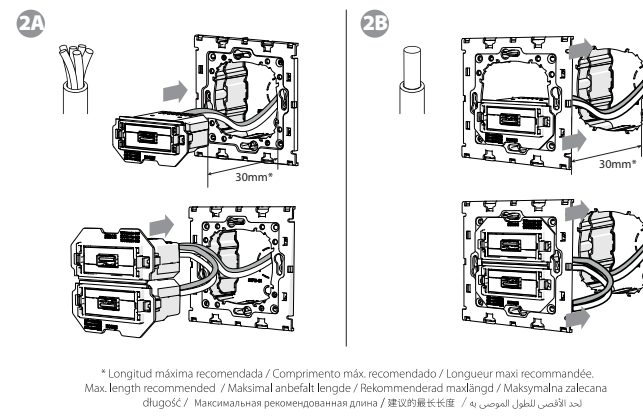
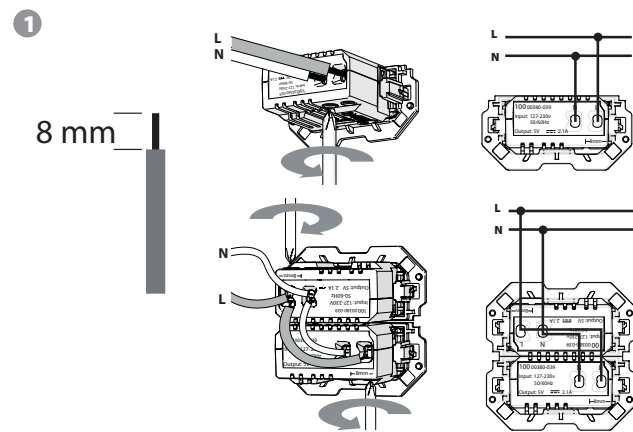

* Longitud máxima recomendada / Comprimento máx. recomendado / Longueur maxi recommandée.
Max. length recommended / Maksimal anbefalt lengde / Rekommenderad maxlängd / Maksymalna zalecana długość / Максимальная рекомендованная длина / 建议的最长长度 / الحد الأقصى للقطر الموصى به

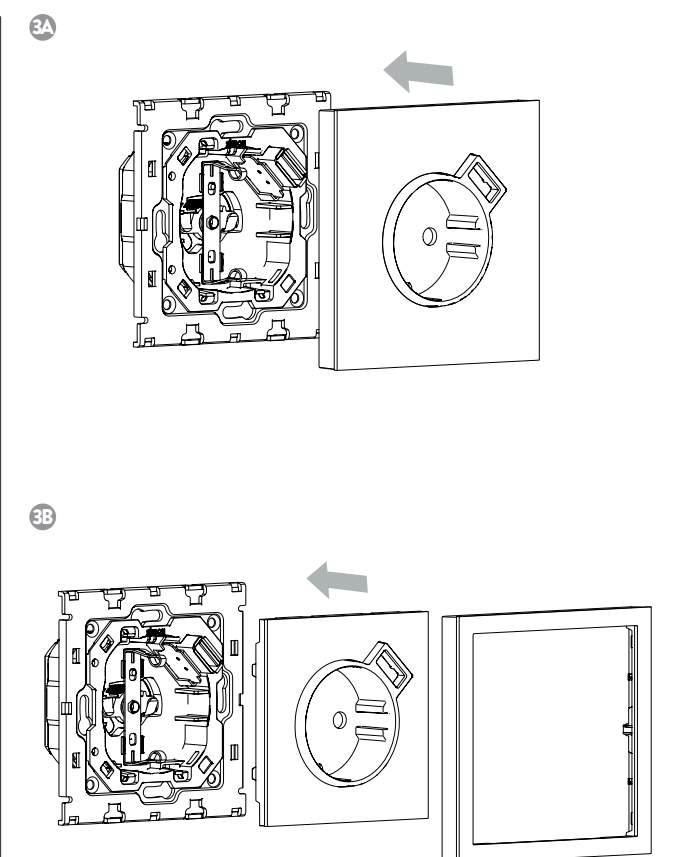
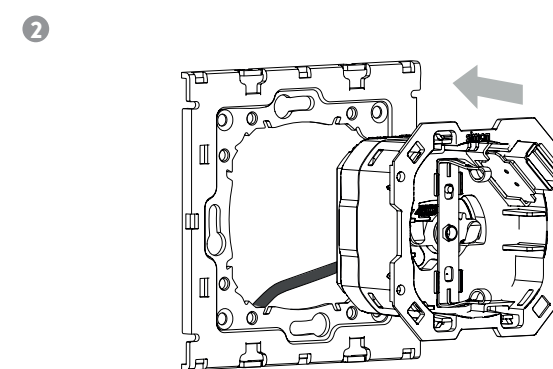
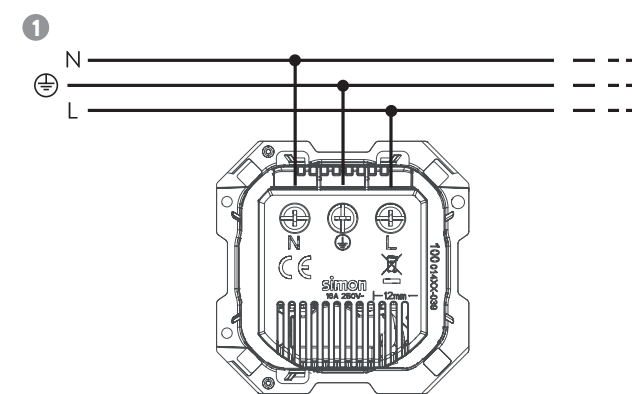
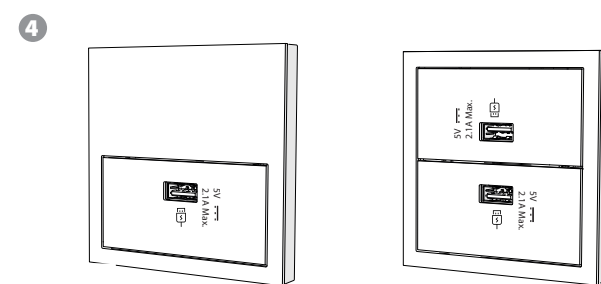
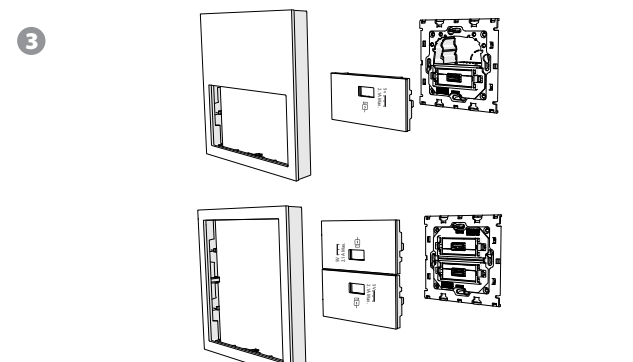

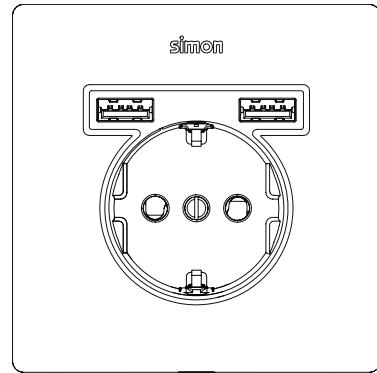

27190610-09X / 2491432-0XX

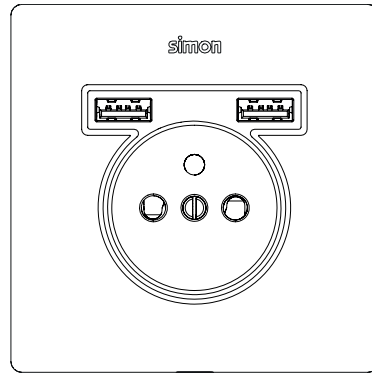

27193610-09X / 2491458-0XX

Technical Specifications

230V~ 50Hz (±10%)	16A / 250V~	35°C 0°C	5V ~ 2,1A Max. Standby <100mW
90% HR	IP20	Average active efficiency: 80% (1)	Low load efficiency (10%): 81% (2)
			CE

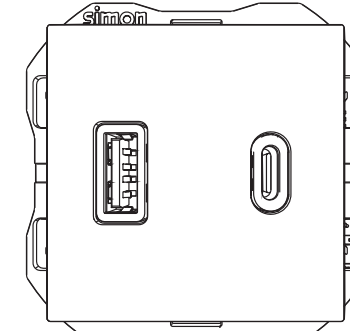

20000296-09x

Technical Specifications

USB INPUT 127-230V~ 50/60Hz 250mA	35°C 5°C	IP20	CE	
OUTPUT	AVERAGE ACTIVE EFFICIENCY(1)	LOW LOAD EFFICIENCY (2)	NO LOAD CONSUMPTION (3)	
5,0 VDC - 3,1 A - 15,5 W	80,0%	81,0%	< 0,30 W	
5,0 VDC - 2,0 A - 10,0 W 9,0 VDC - 2,0 A - 18,0 W 12,0 VDC - 1,5 A - 18,0 W				
5,0 VDC - 3,1 A - 15,5 W 9,0 VDC - 2,0 A - 18,0 W 12,0 VDC - 1,5 A - 18,0 W				

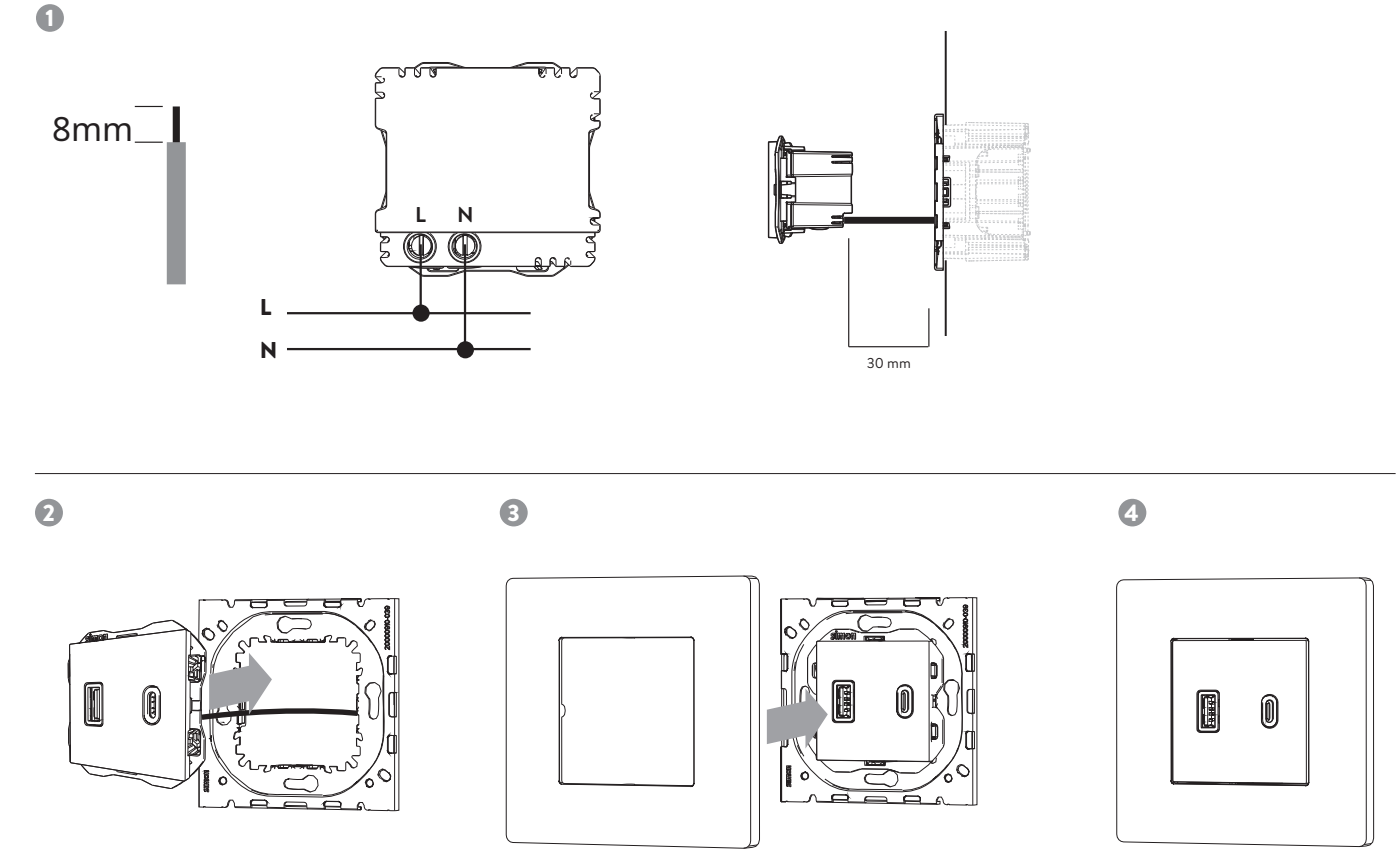
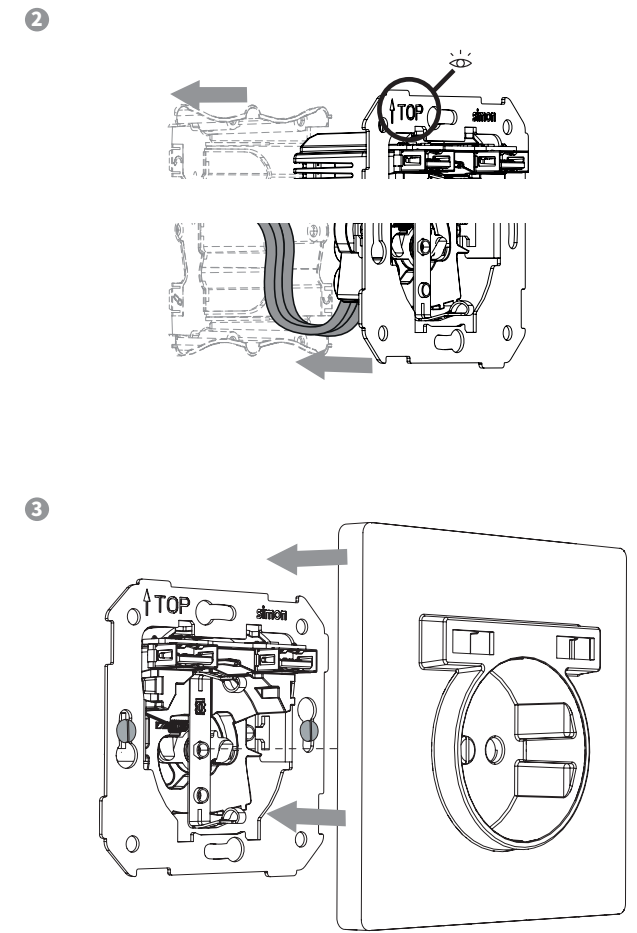
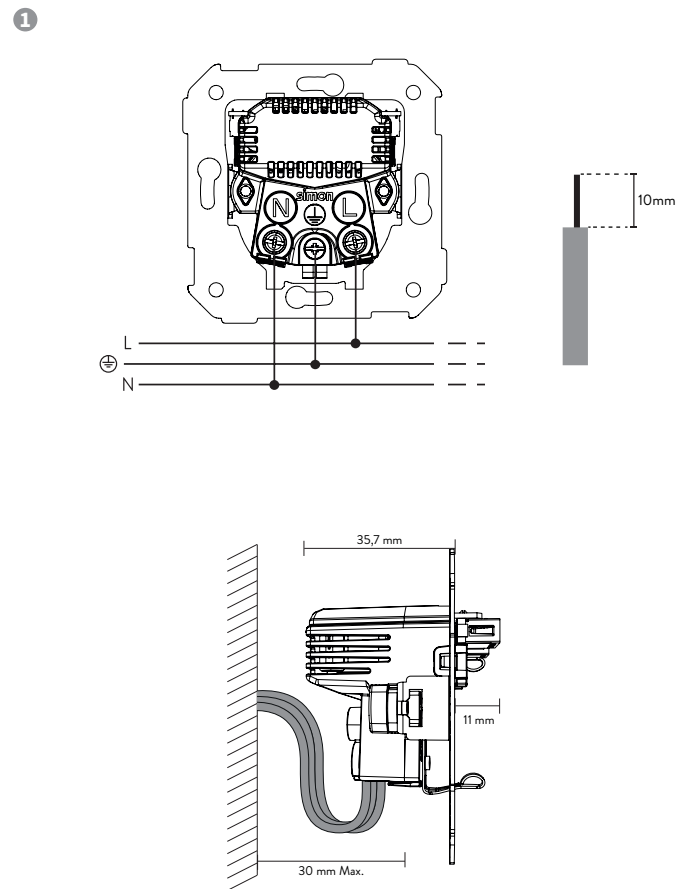

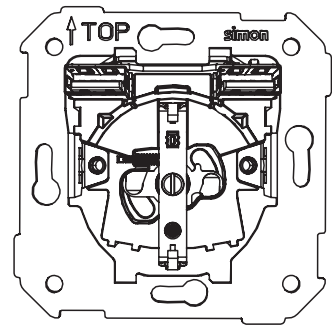

SCHUKO SOCKET
+ 2 USB A+A
7501432-039

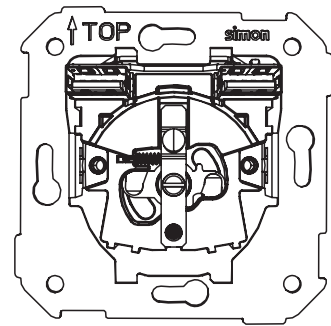

FRENCH SOCKET
+ 2 USB A+A
7501458-039

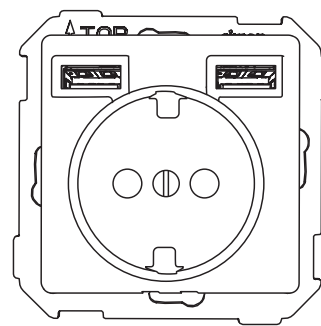

SCHUKO SOCKET
+ 2 USB A+A + COVER
8201432-0XX

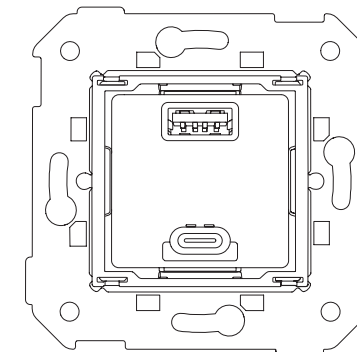

7511296-039

Technical Specifications

USB I/P: 230V~ 50Hz (+10%)	16A 250V~	35°C 0°C	90% HR	IP20
USB O/P: USB Total: 5,0VDC 2,1A 10,5W 2x USB A max: 5,0VDC 2,1A 10,5W	Low load efficiency (10%): 82,5% (1)	Average active efficiency: 81,0% (2)	Standby: 0,08W (3)	

Technical Specifications

230V~ 50Hz (±10%)	127 VAC 60Hz (±10%)	35°C 0°C	18W 5V - 3.1 A 9V - 2.0 A 12V - 1.5 A
90% HR	IP20	Average active efficiency: 80% (1)	Low load efficiency (10%): 81% (2)
		Standby: <100mW (3)	

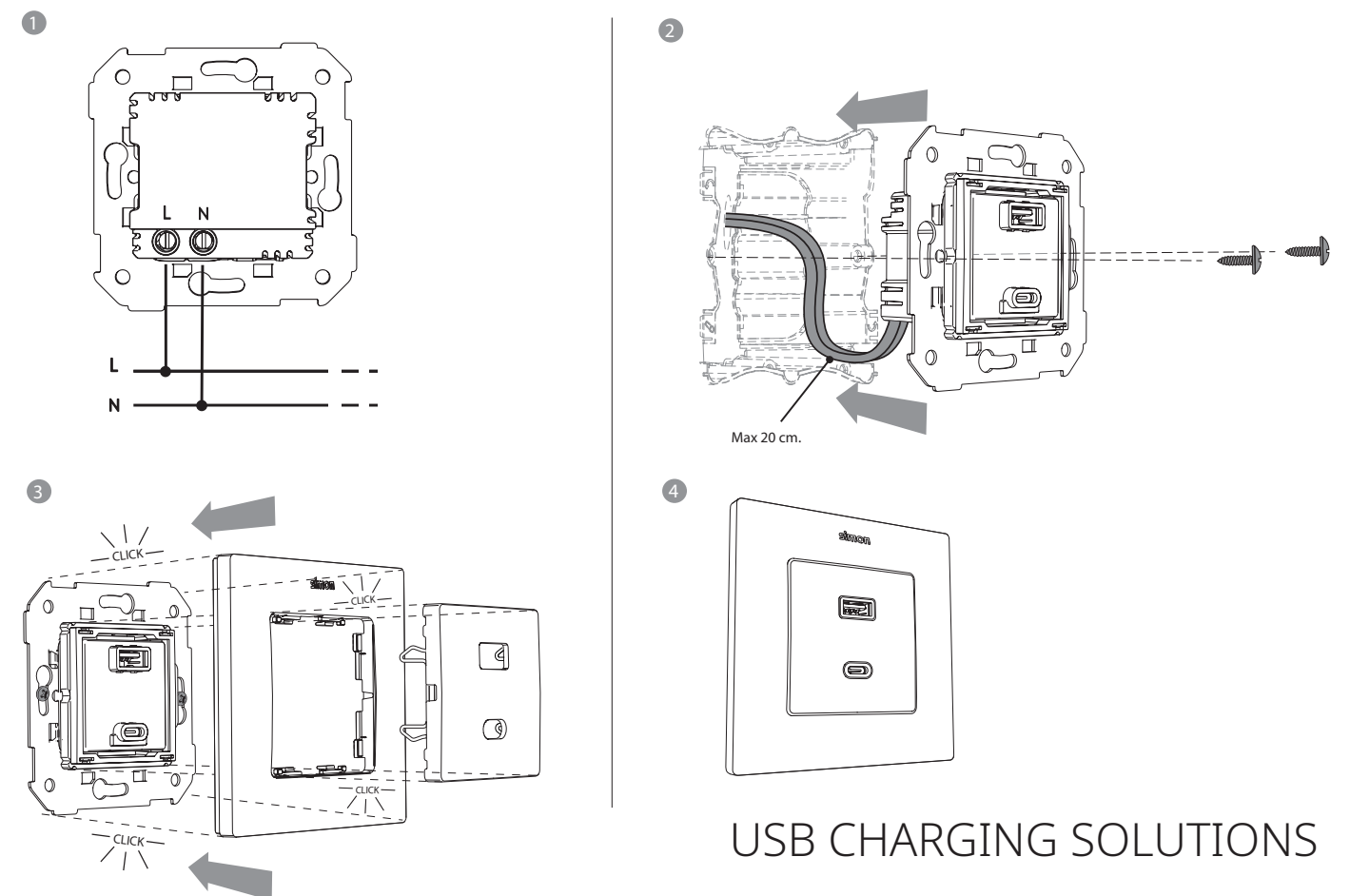
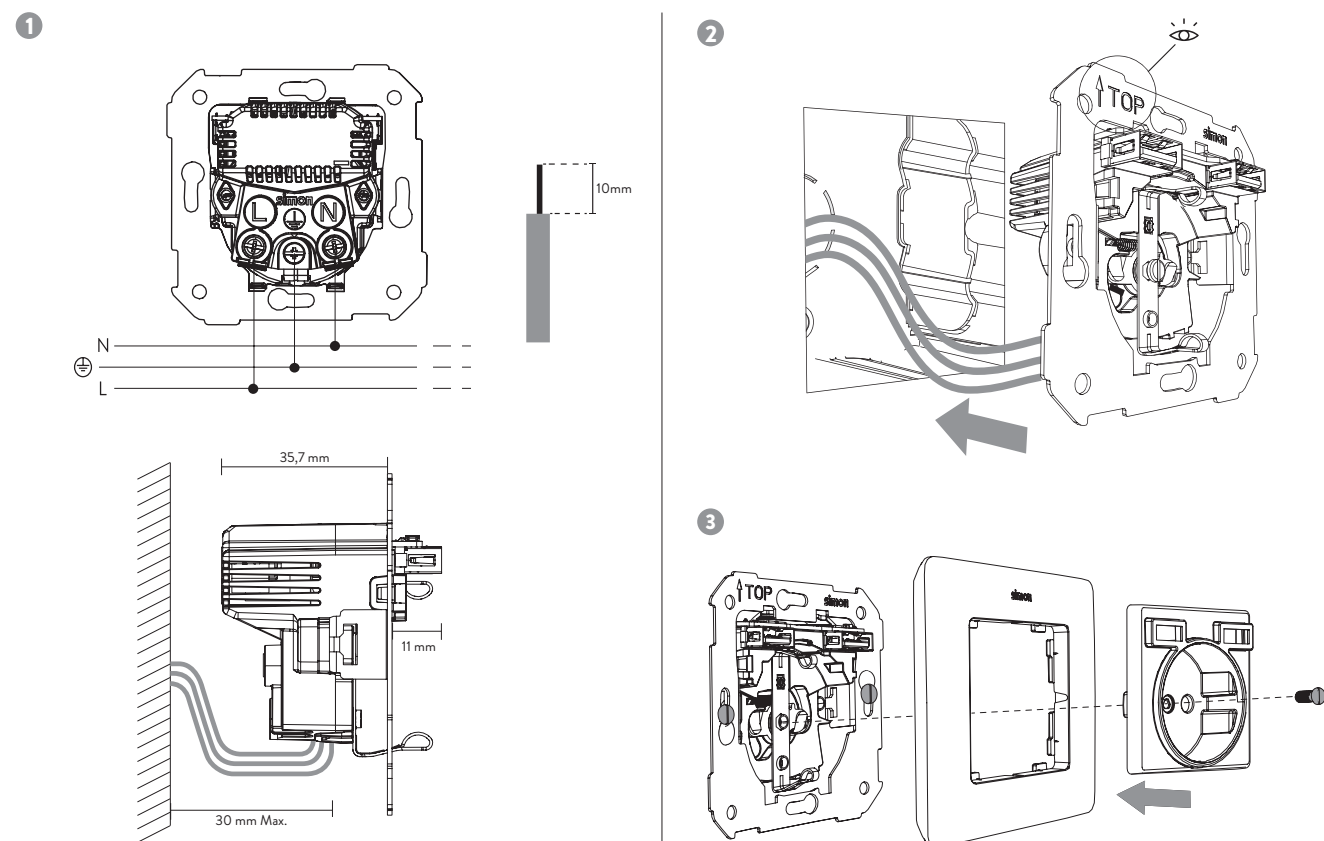

USB CHARGING SOLUTIONS

TECHNICAL INFORMATION

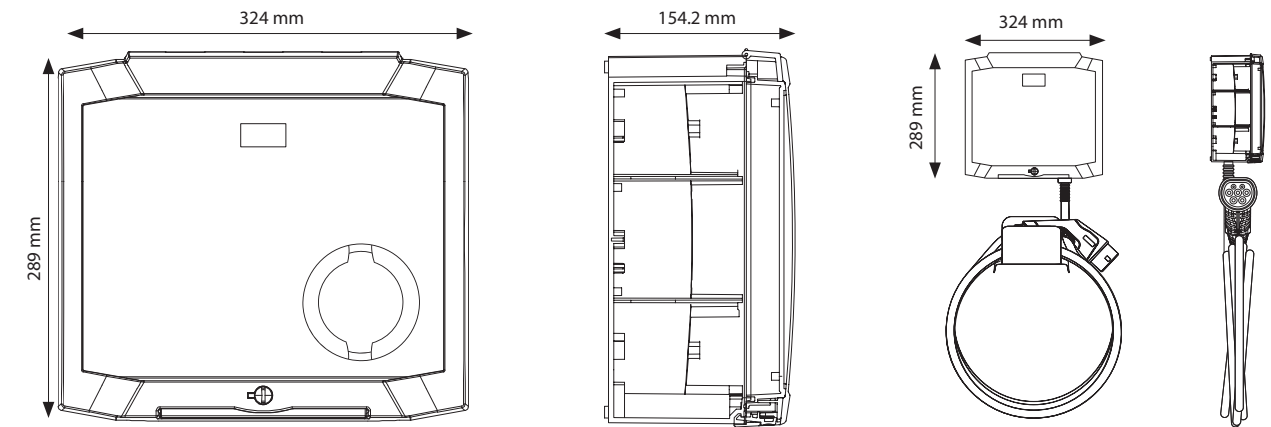
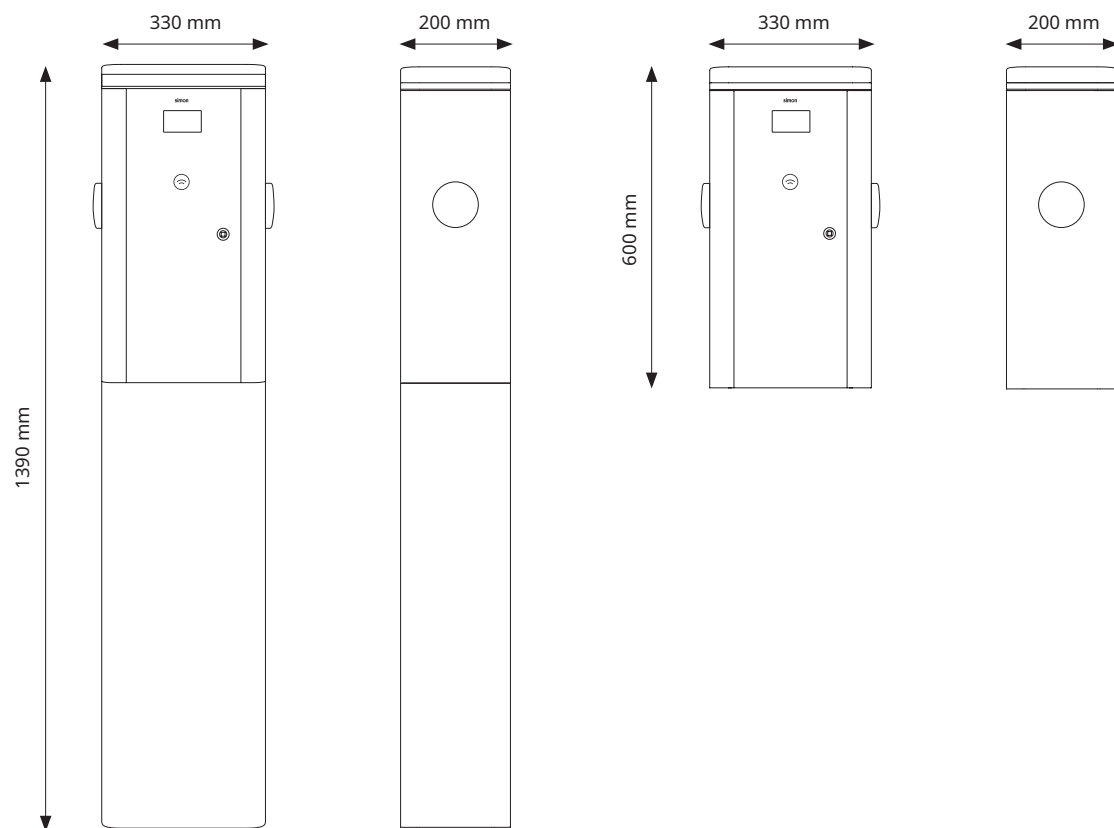

Technical Specifications



Technical Specifications



Model		06X0211-100	06X0212-100	06X0221-100	06X0222-100	06X0231-100	06X0232-100	06X0241-100	06X0242-100	06X1211-100	06X1211-300	06X1212-100	06X1213-100	06X1221-100	06X1221-300	06X1222-100	06X1223-100	06X1231-100	06X1231-300	06X1232-100	06X1233-100	06X1241-100	06X1241-300	06X1242-100	06X1243-100
Power supply:	Single-Phase 230 V 50 Hz (1P+N+E)	-	-	-	-	X	X	X	X	-	-	-	-	-	-	-	-	X	X	X	X	X	X	X	X
	Three-Phase 400 V 50 Hz (3P+N+E)	X	X	X	X	-	-	-	-	X	X	X	X	X	X	X	X	-	-	-	-	-	-	-	-
Connector types / Max. output current:	2 x Socket Type 2	32A	-	32A	-	32A	-	32A	-	32A	32A	-	-	32A	32A	-	-	32A	32A	-	-	32A	32A	-	-
	2 x Cable Type 2 Straight 5 m	-	32A	-	32A	-	32A	-	32A	-	-	32A	-	-	-	32A	-	-	-	32A	-	-	-	32A	-
	2 x Cable Type 2 Spiral 4 m	-	-	-	-	-	-	-	-	-	-	-	-	32A	-	-	-	-	-	-	-	-	-	-	32A
Electric protections:	Maximum equipment input power (config.)	44 kW 64A	44 kW 64A	22 kW 32A	22 kW 32A	14.8 kW 64A	14.8 kW 64A	7.4 kW 32A	7.4 kW 32A	44 kW 64A	44 kW 64A	44 kW 64A	44 kW 64A	22 kW 32A	22 kW 32A	22 kW 32A	22 kW 32A	14.8 kW 64A	14.8 kW 64A	14.8 kW 64A	14.8 kW 64A	7.4 kW 32A	7.4 kW 32A	7.4 kW 32A	7.4 kW 32A
	Residual current circuit breaker 30 mA Class A + C-curve miniature circuit breaker	X	X	X	X	X	X	X	X	X	X	X	X	X	X	X	X	X	X	X	X	X	X	X	X
Workplace solutions	Residual DC current detection 6mA	X	X	X	X	X	X	X	X	X	X	X	X	X	X	X	X	X	X	X	X	X	X	X	X
	Modem connectivity	-	-	-	-	-	-	-	-	X	X	X	X	X	X	X	X	X	X	X	X	X	X	X	X

Ref. Simon		0640141-000	0641141-000	0640141-100	0641141-100	0640121-000	0641121-000	0640121-100	0641121-100	0640142-000	0640142-100	0641142-100	0640122-000	0641122-000	0640122-100	0641122-100	0640341-000	0641341-000	0640341-100	0641341-100	0640321-000	0641321-000
Power supply / Maximum power	230V - 50Hz / 7,4 kW 32 A	X	X	X	X					X	X	X					X	X	X	X		
	400V - 50Hz / 22 kW 32 A					X	X	X	X				X	X	X	X					X	X
Connector	Socket T2	X	X	X	X	X	X	X	X													
	Cable 5m T2									X	X	X	X	X	X	X						
	Schuko (10A) + Socket T2																X	X	X	X	X	X
Electric protections	Without protections	X	X			X	X			X			X	X			X	X			X	X
	Residual current circuit breaker 30 mA Class A + C-curve miniature circuit breaker			X	X			X	X			X	X			X	X			X	X	
Workplace solutions	Residual DC current detection 6mA	X	X	X	X	X	X	X	X	X	X	X	X	X	X	X	X	X	X	X	X	X
	Modem 4G		X	X	X	X	X	X	X			X	X			X				X		X

TECHNICAL INFORMATION

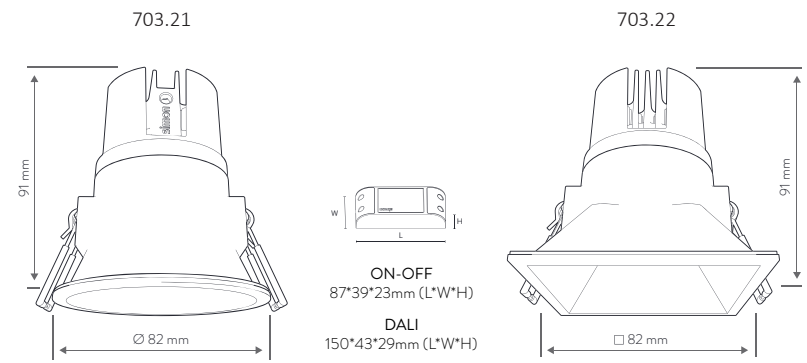

ON-OFF
87*39*23mm (L*W*H)
DALI
150*43*29mm (L*W*H)

Technical Specifications

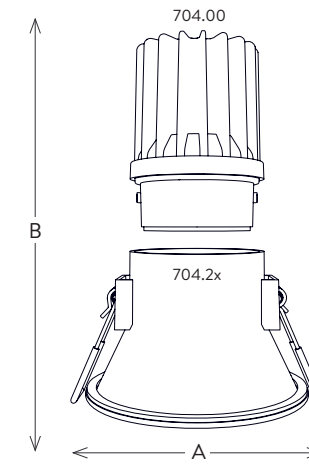
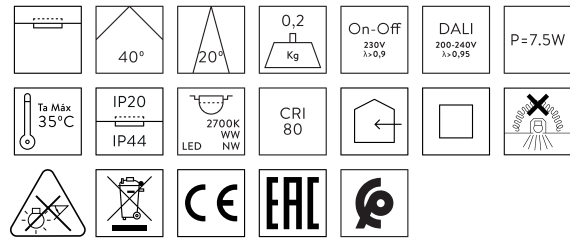

	AxB	IP44	IP65	IP20	
704.21	Ø82x105	IP44	IP65	IP20	-
704.22	82x82x105	IP44	IP65	IP20	-
704.28	Ø92x113	IP44	IP65	IP20	-
704.23	Ø82x80	IP20	IP65	IP20	30°
704.24	82x82x80	IP20	IP65	IP20	30°

Technical Specifications

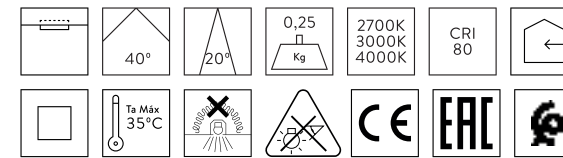

DRIVER	VOLTAGE (PRI)	POWER (W)	PF
On-Off	220-240V	12	$\lambda > 0,9$
On-Off Bitension	120-277V	10	$\lambda > 0,9$
1-10V	220-240V	12	$\lambda > 0,95$
DALI	220-240V	12	$\lambda > 0,95$

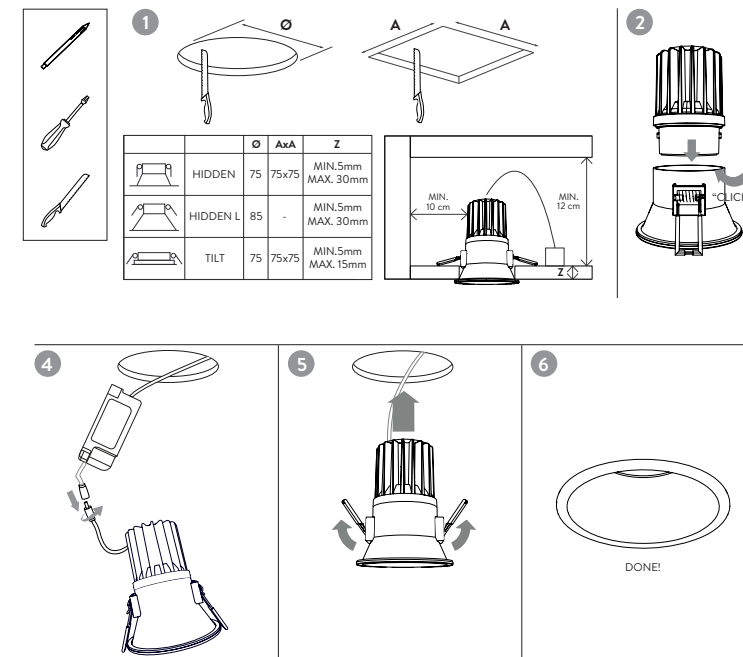
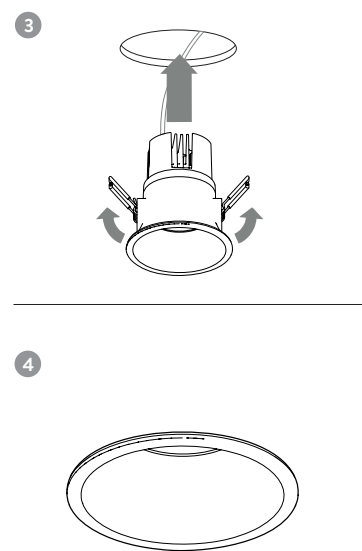
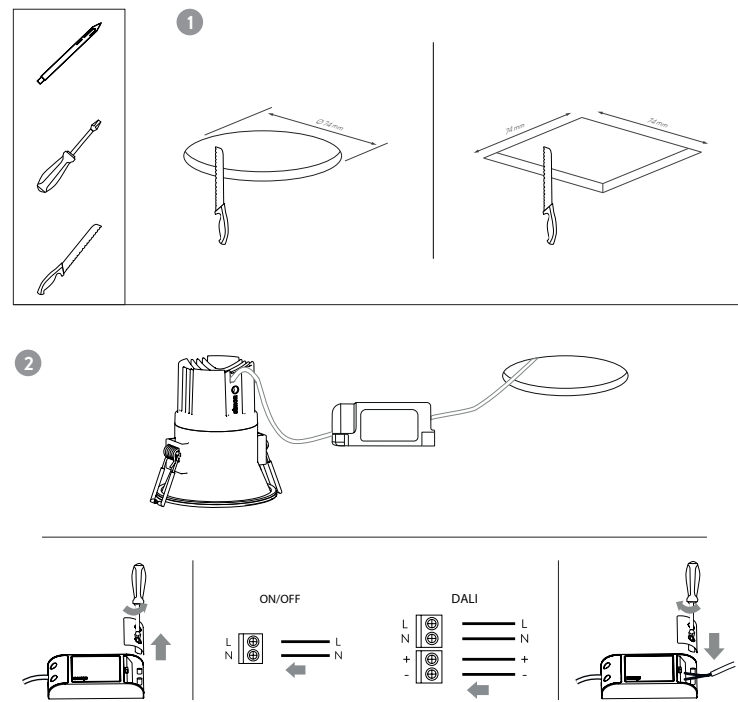

Dimensiones - Dimensões - Dimensions - Dimensions - 尺寸 - Размеры - الأبعاد

Model	Height	Width
DALI	42,5 mm	150 mm
ON-OFF	38 mm	100 mm
1-10	44 mm	131,5 mm

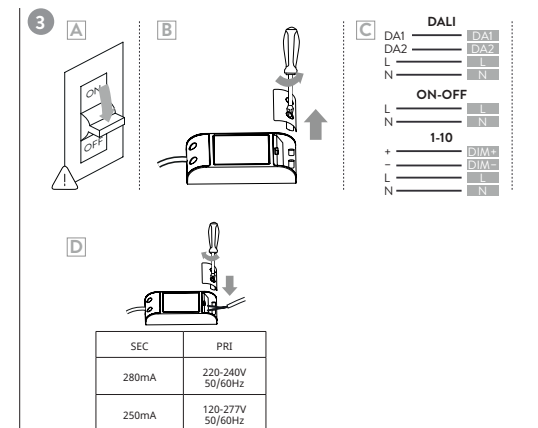

If you have a project in hand, get inspired by our Feel Project Book:

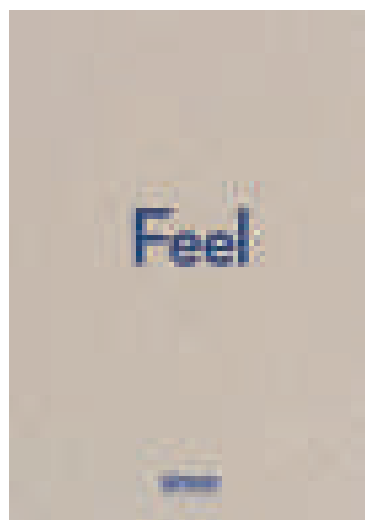

Consult our collections of mechanisms and choose the aesthetic that best suits your project:

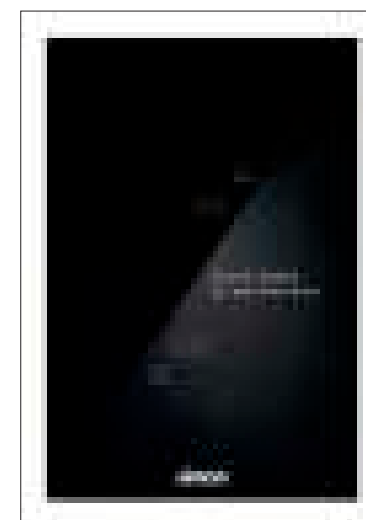

If you liked the linear lighting, download our catalogue of Linear lighting solutions for furniture:



Find out about Simon's interior lighting:





www.simonelectric.com



SIMON S.A.U.

Diputación, 390-392
08013 Barcelona
Tel. 651 761 336

Projects Department

Tel. 651 761 346
Email: proyectos@simon.es

Customer Service

Tel. 651 761 314

**Technical
Customer Service**

Tel. 651 761 346
Email: sat@simon.es