

Travertine Cross Walnut



Porcelain Pavers

Our Travertine Cross Series™ in Walnut color porcelain paver perfectly replicates the shades of ochre within a natural travertine stone without the maintenance and upkeep required for a natural stone travertine. Completely nonporous, they will not stain and require no sealing.

Tile Tech® hardscape systems provide architects and design professionals with a complete solution to transform any roof deck, walkway, driveway, courtyard, or patio into beautiful, useful spaces. Embracing USGBC LEED standards, our paving products boast a composition that includes 35% pre-consumer recycled materials. With no traces of Volatile Organic Compounds (VOC) and a Solar Reflectance Index (SRI) of ≥ 32 , porcelain pavers emerge as an eco-friendly choice that goes beyond conventional paving solutions.





VISIT OUR 3D MODELS FOR INSTALLATION TIPS!



Specifications

Available Sizes (Rectified)

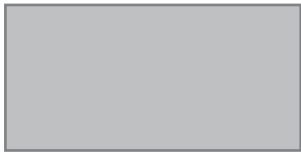
-  11-1/2" x 23-1/2"
293 x 597 mm
-  23-1/2" x 23-1/2"
597 x 597 mm
-  23-1/2" x 47-1/2"
597 x 1207 mm

Color and Shade Variation

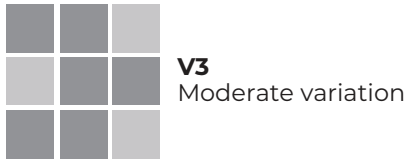

USGBC LEED® Opportunities

- Recycled Content:
MR Credit 4.1 and 4.2 (2 LEED pts.)
- Low Emmitting Materials
EQ Credit 4.2 (1 LEED pt.)
- Innovation in Design
ID Credit 1.1 - 1.4 (1-4 LEED pts.)
- Heat Island Effect (Non-roof)
SS Credit 7.1 (1 LEED pt.)
- Regional Materials (500 mi)
EQ Credit 4.2 (1 LEED pt.)

Shipping Details

- Packaging (12" x 24")
160 pcs. | 320 Sq.Ft. | 2,900 lbs./pallet
- Packaging (24" x 24")
72 pcs. | 279 Sq.Ft. | 2,700 lbs./pallet
- Packaging (24" x 48")
32 pcs. | 256 Sq.Ft. | 2,350 lbs./pallet

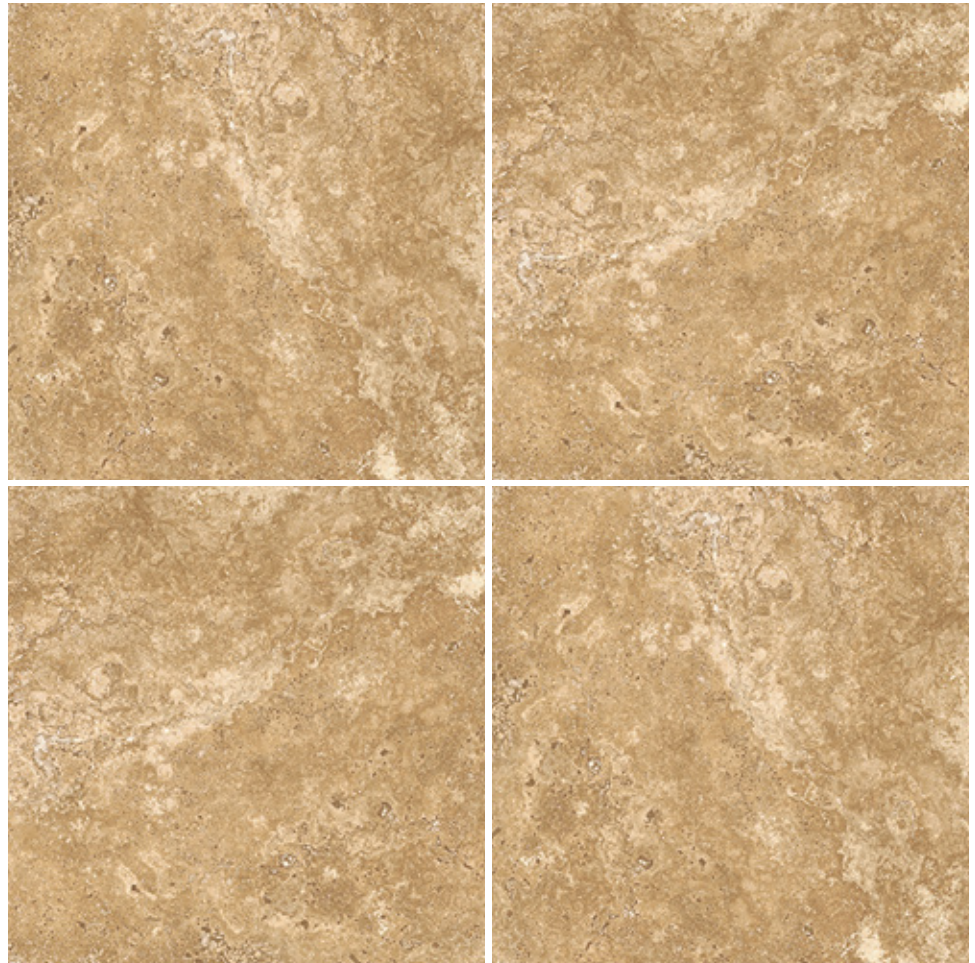

Thickness:	3/4" 19 mm	
Weight:	9 lbs/Sq.Ft.	
Water Absorption:	Max. 0.05%	ISO10543-3
Static Load (Center)	≥1,840 lbf.	ASTM N/A, EN 12825
Bending Strength	3,300 lbs.	ASTM C-648, ISO 10545-4
Distribution Load	2,500 lbs.	ASTM N/A, EN 12825
Slip Resistant	R11	DIN51130
COF (Wet, Dry)	>0.60	ASTM C-1028-7, ISO N/A
Abrasion Resistant	Yes (Class 5)	ASTM C-1027, ISO 10545-6
Stain Resistant	Yes (Class 5)	ASTM C-1378, ISO 10545-14
Frost Resistant	Yes	ASTM C-1026, ISO 10545-12
Chemical Resistance	Yes	ASTM C-650, ISO 10545-13
Solar Reflectance (SRI)	50	
Rectified	Yes	

Full test reports and specification details available on our website.

