



**olé** Light, love  
& lamps

NEWS 2024



Take care of your light because it bathes those around you, the relationships and memories you have with them forever. We do it with confidence and commitment to our family, inside and outside Olé.

Take care of your light because it bathes what you do and all the effort you put into it. We do it in every design, in every lamp and in every detail for more than 30 years.

Take care of your light because it bathes your world, your parents' world and your children's world. We do it thinking about the sustainability of every decision, of every process and every manufacture.

Take care of your light because it is the source of your ideas. We do it through our own solutions, non-conformist and efficient, that help you to illuminate your own. And because we think that the world would be a better place bathed in it.

Cuida de tu luz porque baña a los que te rodean, las relaciones y los recuerdos que tienes para siempre con ellos. Nosotros lo hacemos con confianza y compromiso con nuestra familia, dentro y fuera de Olé.

Cuida de tu luz porque baña lo que haces y todo el esfuerzo que pones en ello. Nosotros lo hacemos en cada diseño, en cada lámpara y en cada detalle desde hace más de 30 años.

Cuida de tu luz porque baña tu mundo, el de tus padres y el de tus hijos. Nosotros lo hacemos pensando en la sostenibilidad de cada decisión, de cada proceso y de cada fabricación.

Cuida de tu luz porque es el origen de tus ideas. Nosotros lo hacemos a través de soluciones propias, inconformistas y eficientes que te ayudan a iluminar las tuyas. Nosotros cuidamos de la luz de Valencia porque sabemos que es única. Y porque pensamos que el mundo sería un lugar mejor bañado por ella.



# Index

History	04
Awards	08
Customization	09
Sustainability	10
Index by category	12
Finishes	54

# Lighting your ideas since 1992

At Olé Lighting we have believed in well-done work for more than 30 years. We are proud of our origins, our products, our people and our way of doing lighting. And this catalogue is the reflection of the effort of an adventure that began in 1992 and in which we continue with the same enthusiasm as on the first day.

We design and manufacture quality handmade lamps, always with a human touch. And we do it from Valencia for the whole world.

We take care of light and people, building relationships of trust based on honesty and closeness with our big family, inside and outside Olé, and we are constantly searching for new lighting solutions to give light to our customers ideas.

We are always committed to offering decorative and technical lighting adapted to market trends while remaining true to our style, and we strive every day to be a sustainable, conscious and responsible company in all areas of activity.

That is why we guarantee our own, non-conformist and efficient lighting solutions.





En Olé Lighting creemos en el trabajo bien hecho desde hace más de 30 años. Estamos orgullosos de nuestro origen, de nuestros productos, de nuestra gente y de nuestra forma de hacer iluminación. Y este catálogo es el reflejo del esfuerzo de una aventura que comenzó en 1992 y en la que seguimos con la misma ilusión del primer día.

Diseñamos y fabricamos lámparas de calidad de forma artesanal, siempre con un toque humano. Y lo hacemos desde Valencia para todo el mundo.

Cuidamos de la luz y de las personas construyendo relaciones de confianza basadas en la honestidad y la cercanía con nuestra gran familia, dentro y fuera de Olé.

Estamos en permanente búsqueda de nuevas soluciones de iluminación para dar luz a las ideas de nuestros clientes. Siempre con el compromiso de ofrecer iluminación decorativa y técnica adaptada a las tendencias del mercado sin dejar de ser fieles a nuestro estilo.

Nos esforzamos cada día para ser una empresa sostenible, consciente y responsable en todas las áreas de actividad. Por ello, garantizamos soluciones de iluminación propias, inconformistas y eficientes.

# Proudly made in Valencia, Spain

We are light. And at Olé Lighting we think that the world would be a better place if it were illuminated with the warm, clean, honest and optimistic light that bathes Valencia.

We design and manufacture from Valencia for the world and that sets us apart in terms of quality, sustainability and social commitment. We offer solutions that respond to the lighting needs of interior designers, architects and lighting professionals with a circle of suppliers who are close, trustworthy and of proven quality. A way of supporting the local trade and creating community.

We are committed to an original, functional product designed by our team led by Fernando Martínez, collaborating occasionally with renowned or young designers.

Our collections cover different styles and uses in decoration thanks, in part, to the different materials we offer. We create lamps that not only illuminate, but also transmit design and, above all, tell stories.

We give light to any idea you propose.

Somos luz. Y en Olé Lighting pensamos que el mundo sería un lugar mejor si estuviera iluminado con la luz cálida, limpia, honesta y optimista que baña Valencia.

Diseñamos y fabricamos desde Valencia para el mundo y eso nos diferencia en calidad, sostenibilidad y compromiso social. Ofrecemos soluciones que dan respuesta a las necesidades de iluminación de interioristas, arquitectos y profesionales de la iluminación con un círculo de proveedores próximo, de confianza y de calidad contrastada. Una forma de apoyar al tejido local y de crear comunidad.

Apostamos por un producto original, funcional y diseñado por nuestro equipo dirigido por Fernando Martínez, colaborando ocasionalmente con diseñadores de reconocido prestigio o con jóvenes diseñadores.

Nuestras colecciones abarcan diferentes estilos y utilidades en decoración gracias, en parte, a los distintos materiales que ofrecemos. Creamos lámparas que no solo iluminan, también transmiten diseño y, sobre todo, cuentan historias.

Damos luz a cualquier idea que te propongamos.





**FERNANDO MARTÍNEZ**  
Owner & Head of Design - Olé Lighting



**LORENA GARCÍA**  
Technical Designer - Olé Lighting



**MANEX BILBAO**  
Product Designer - Manex Bilbao Studio



# Awards



## MORGANA

Archiproducts Awards 2023 – Winner  
**Sustainability Product Design**

2023



## AVATAR TWIST

Darc Awards 2021 – Shortlisted  
**Best Architectural Lighting Product**

2021



## AVATAR

German Design Awards 2020 – Winner  
**Excellent Product Design**



2020



## PEPO

German Design Awards 2019 – Special Mention  
**Excellent Product Design**

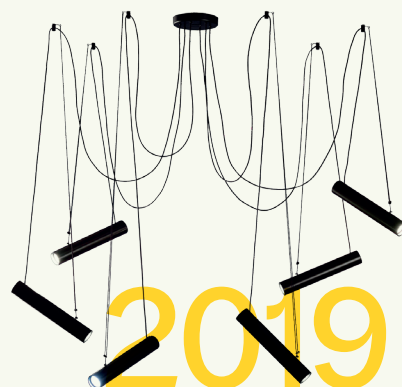

2019

# Custom made lighting

We take care of our family by offering custom, sustainable and efficient products, adapting our designs by modifying sizes and colours according to the needs of our customers.

In this way, we can offer customised lamps that illuminate any idea you propose. Moreover, as we are manufacturers and have our own department, we can also advise on lighting studies.

Cuidamos de nuestra familia ofreciendo productos personalizados, sostenibles y eficientes. Adaptamos nuestros diseños modificando medidas y colores en función de las necesidades de nuestros clientes.

De esta manera, podemos ofrecer lámparas personalizadas que iluminen cualquier idea que te propongas. Además, al ser fabricantes y disponer de departamento propio, también podemos asesorar en estudios lumínicos.



SIZE



COLOR

# Lighting for the Earth

At Olé Lighting we strive to be a sustainable, conscious and responsible company from our internal processes to our design.

We choose sustainable materials such as cord made from recycled bottles or esparto grass obtained from various wild plants. We collaborate with national suppliers thus reducing our carbon footprint and we follow artisanal processes in our manufacturing to be more efficient. And we do it with love and conviction. Because we only have one planet and we must take care of it.

## OCEANS WITHOUT PLASTIC

Under the slogan oceans without plastic we have designed a collection of polyester cord made from recycled plastic bottles, collected from the sea and our environment.

Since we started in 2022 until the end of 2023, we have removed a total of 13,176 kg of plastic with our cord lamps. In this way we contribute to the reduction of this environmentally harmful material, and reuse it by incorporating it in products that have a long useful life.

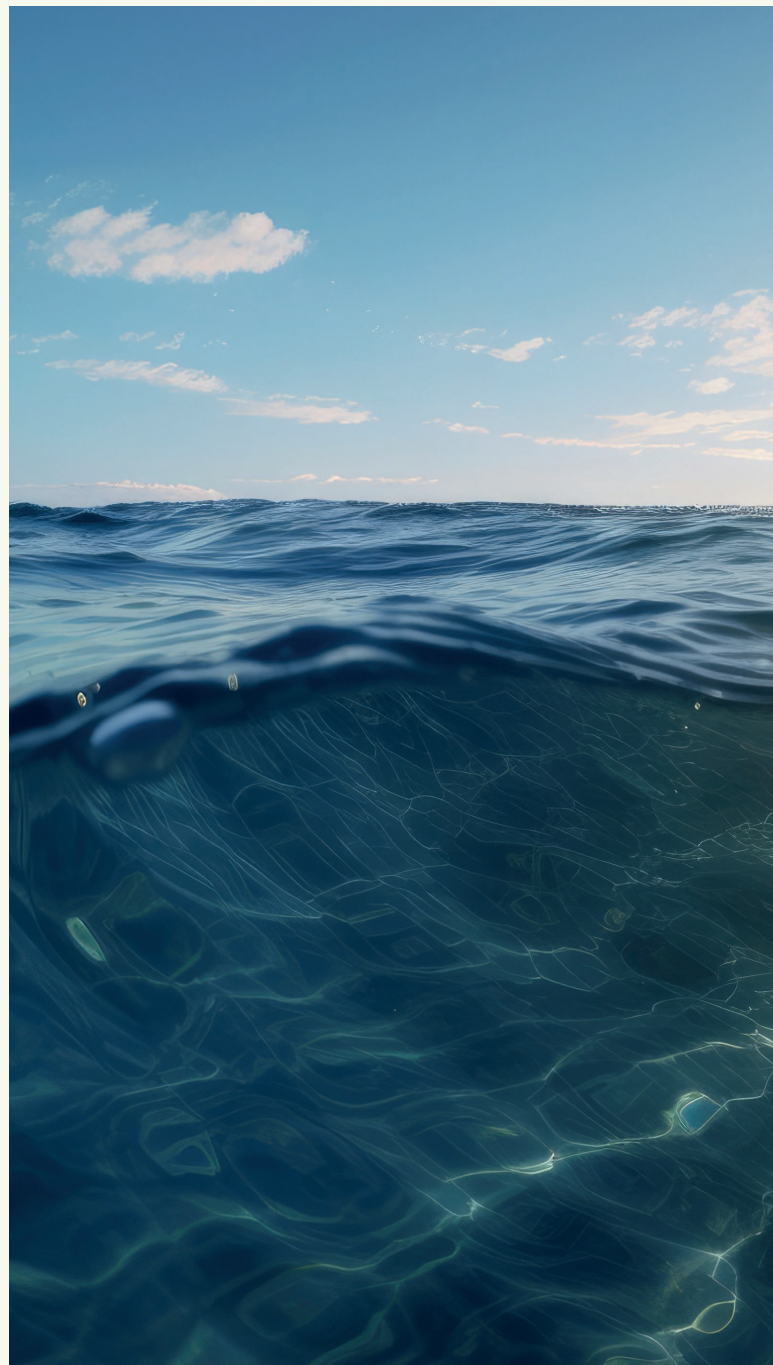

# OCEANS WITHOUT PLASTIC



En Olé Lighting nos esforzamos por ser una empresa sostenible, consciente y responsable desde nuestros procesos internos hasta el diseño.

Elegimos materiales sostenibles como cuerda fabricada con botellas recicladas o esparto obtenido de diversas plantas silvestres.

Colaboramos con proveedores nacionales reduciendo así nuestra huella de carbono y seguimos procesos artesanales en nuestra fabricación para ser más eficientes. Y lo hacemos con cariño y convicción. Porque solo tenemos un planeta y debemos cuidarlo.

## OCEANS WITHOUT PLASTIC

Bajo el lema Oceans Without Plastic hemos diseñado una colección de cuerda hecha con poliéster fabricado a partir de botellas de plástico recicladas, recogidas del mar y de nuestro entorno.

Desde que empezamos en 2022 hasta finales de 2023, hemos retirado un total de 13.176 Kg de plástico con nuestras lámparas de cuerda. De esta manera contribuimos en la reducción de este material tan perjudicial para el medioambiente y lo reusamos al incorporarlo en productos que tienen una larga vida útil.

# Wall Lamps

New  
Collection



HABE

48

# Table Lamps

New  
Collection



HABE

48

# Floor Lamps

New  
Collection



HABE

48



HABE

48

# Ceiling Lamps

New  
Collection



SONORA 24



SONORA 24



SONORA 24

# Wall to wall

New  
Collection



ESTELA 44

# Suspensions

New  
Collection



MEDUSA

18

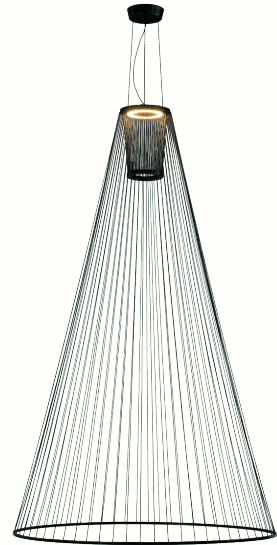

MEDUSA

18

New  
Collection



SONORA

24



SONORA

24



SONORA

24



New  
Collection



PAMPA

34



PAMPA

34

New  
Collection

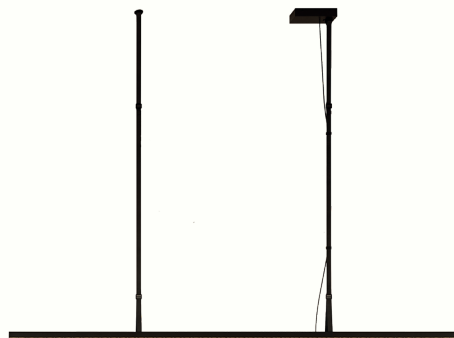

KATANA

40

# New Collections

Acompáñanos y descubre las posibilidades que te ofrecemos con nuestras nuevas propuestas de iluminación. Introducimos novedades como el uso de material fonoabsorbente para crear ambientes más tranquilos y confortables, hasta propuestas diseñadas especialmente para iluminar espacios al aire libre con estilo y funcionalidad. Además, te invitamos a descubrir nuestro nuevo modelo cambiante, que te permitirá personalizar y adaptar su diseño según tus preferencias en cualquier momento.

Join us and discover the possibilities we offer you with our new lighting proposals. We introduce novelties such as the use of sound-absorbent material to create quieter and more comfortable atmospheres, as well as proposals specially designed to illuminate outdoor spaces with style and functionality. In addition, we invite you to discover our new changing model, which will allow you to customize and adapt its design according to your preferences at any time.

SUSTAINABLE PRODUCT

MEDUSA  
SONORA  
PAMPA  
KATANA  
ESTELA  
HABE

# MEDUSA

MADE WITH RECYCLED MATERIALS

MEDUSA, “jellyfish” in spanish, has been inspired by the movements of the marine animals from which it takes its name, the elegant ballerinas of the sea that, with their hypnotic choreography, glide lightly through the depths of the oceans. That's MEDUSA. A changing design that captures the beauty and versatility of the nature of the undersea world.

It consists of two versions for different uses. One is presented as a decorative piece that releases an ambient light from the static upper ring, enhancing the design of the lamp from above. And the other with the light in the mobile lower ring, allowing the light to be focused, making it ideal for illuminating surfaces.

MEDUSA está inspirada en los movimientos de los animales marinos de los que toma el nombre, las elegantes bailarinas del mar que, con su hipnótica coreografía, se deslizan con ligereza por las profundidades de los océanos. Así es MEDUSA. Un diseño cambiante que captura la belleza y versatilidad de la naturaleza del mundo submarino.

Esta familia consta de dos versiones de diferente uso. Una se presenta como una pieza decorativa que desprende una luz ambiental estática desde el aro superior, realzando el diseño de la lámpara desde lo alto. Y otra con la luz en el aro inferior móvil, que permite focalizar la luz, siendo idónea para iluminar superficies.



MEDUSA 34100/80 34200/100



MEDUSA 34200/80

CHANGING DESIGN



MEDUSA 34100/100



MEDUSA 34100/100



MEDUSA  
34200/100



MEDUSA 34100/80



MEDUSA  
REF. 34100/80

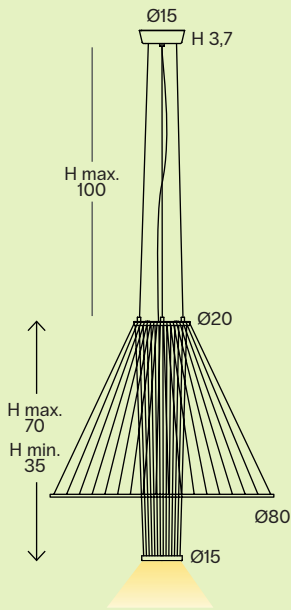

MEDUSA  
REF. 34100/100

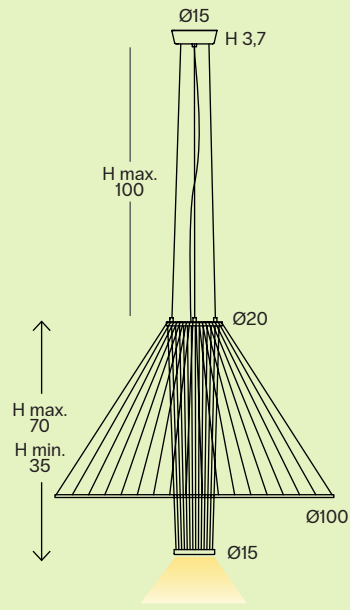

MEDUSA  
REF. 34200/80

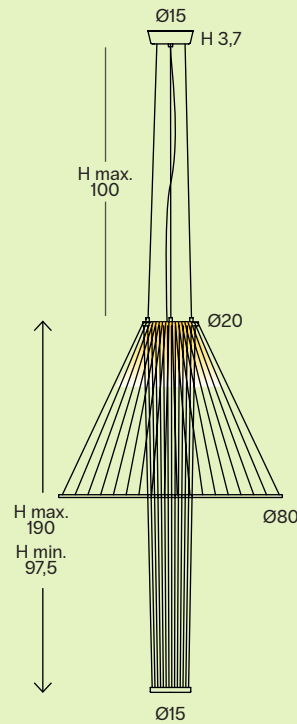

MEDUSA  
REF. 34200/100

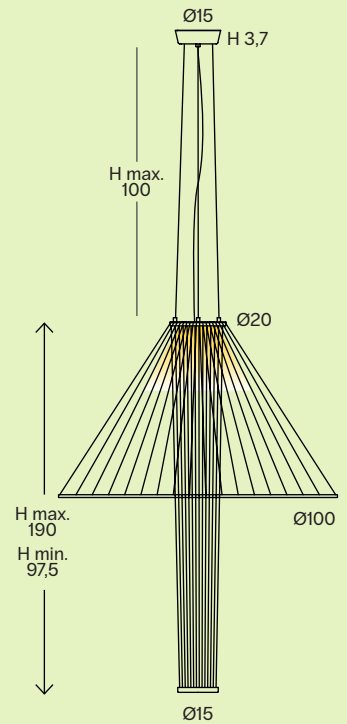

## SUSPENSION / COLGANTE

IP20

## MATERIAL

Metal and recycled cord / Metal y cuerda reciclada

## FINISH / ACABADO

Canopy/Florón:

Matt black / Negro mate

Metal structure/Estructura metal:

Black / Negra

Cord/Cuerda:

Black/Negra

Diffuser/Difusor:

Optical white/Blanco óptico

## INSTALLATION / INSTALACIÓN

PCB-LED 10W 350mA CRI 82

- 3000K 958lm

- 4000K 1003lm

© dim LC © dim Casambi

# SONORA

MADE WITH RECYCLED MATERIALS

A combination of functionality and design. The Sonora desert is a natural environment where nothing is heard but the placid sound of nature. Thus, this family of ceiling and suspension lights is designed with high quality sound-absorbent material to reduce ambient noise while illuminating the space, creating a more peaceful and welcoming atmosphere.

Una combinación de funcionalidad y diseño. El desierto de Sonora es un entorno natural donde no se escucha más que el plácido sonido de la naturaleza. Así, esta familia de plafones y colgantes está diseñada con material fonoabsorbente de alta calidad para reducir el ruido ambiental a la vez que iluminan el espacio, creando una atmósfera más tranquila y acogedora.



SONORA 34831/80 Beige



SONORA 34831/80 Marbled grey



SONORA 34832/80 Beige



SONORA 34833/80 Terracotta



SONORA 34833/80 Beige



SONORA 34033/80 Beige





SONORA 34032/80 Marbled grey



SONORA 34031/80 Beige

**SONORA**  
**REF. 34031/80**

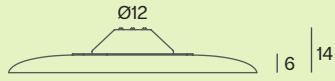

**CEILING LAMP / PLAFÓN**  
**IP20**

**MATERIAL**

Acoustic panel and aluminium /  
Panel acústico y aluminio

**FINISH / ACABADO**

Acoustic panel / Panel acústico:  
Marbled grey, beige and terracotta /  
Gris jaspeado, beige y teja

Base:

Matt black / Negro mate

Frame / Bisel:

Matt black / Negro mate

**INSTALLATION / INSTALACIÓN**

PCB LED 20W 700mA CRI>82

- 3000K 1413lm

- 4000K 1478lm

© dim Casambi    LC dim LC

**SONORA**  
**REF. 34032/80**

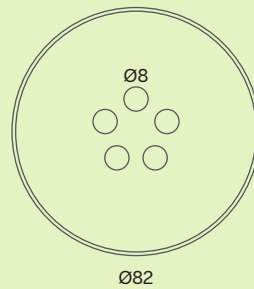
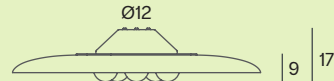

**CEILING LAMP / PLAFÓN**  
**IP20**

**MATERIAL**

Acoustic panel and glass /  
Panel acústico y cristal

**FINISH / ACABADO**

Acoustic panel / Panel acústico:  
Marbled grey, beige and terracotta /  
Gris jaspeado, beige y teja

Base:

Matt black / Negro mate

Spheres / Esferas:

Matt opal glass / Cristal opal mate

**INSTALLATION / INSTALACIÓN**

5 x G9 LED 4W

**SONORA**  
**REF. 34033/80**

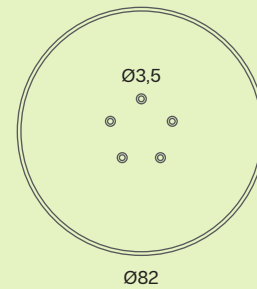
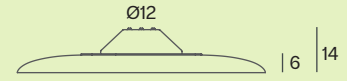

**CEILING LAMP / PLAFÓN**  
**IP20**

**MATERIAL**

Acoustic panel and aluminium /  
Panel acústico y aluminio,

**FINISH / ACABADO**

Acoustic panel / Panel acústico:  
Marbled grey, beige and terracotta /  
Gris jaspeado, beige y teja

Base:

Matt black / Negro mate

Spotlights / Focos:

Matt black / Negro mate

**INSTALLATION / INSTALACIÓN**

5 x COB LED 5W UGR<13 (24°) CRI>92

- 3000K 2500lm

- 4000K 2500lm

P dim PUSH

SONORA  
REF. 34831/80

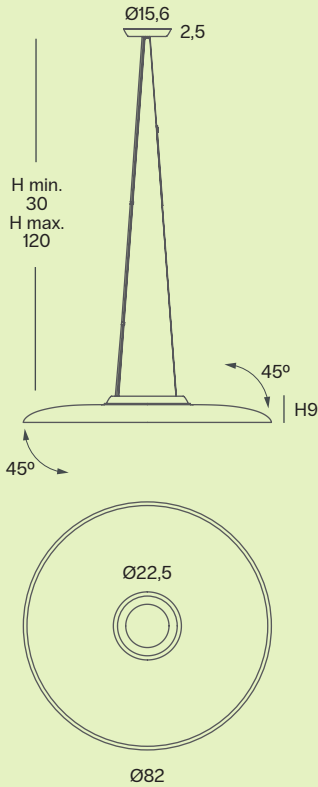

SONORA  
REF. 34832/80

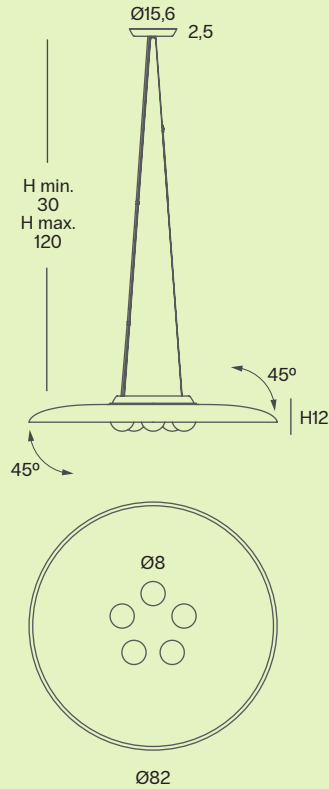

SONORA  
REF. 34833/80

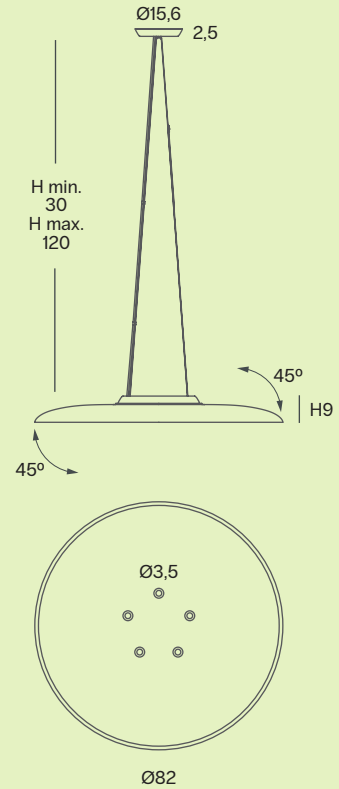

SUSPENSION / COLGANTE  
IP20

**MATERIAL**

Acoustic panel, aluminium and polyester /  
Panel acústico, aluminio y poliéster

**FINISH / ACABADO**

Acoustic panel / Panel acústico:  
Marbled grey, beige and terracotta /  
Gris jaspeado, beige y teja  
Canopy / Florón:  
Matt black / Negro mate  
Polyester belt / Cinta poliéster:  
Black / Negro  
Frame / Bisel:  
Matt black / Negro mate

**INSTALLATION / INSTALACIÓN**

PCB LED 20W 700mA CRI>82  
- 3000K 1413lm  
- 4000K 1478lm

© dim Casambi    LC dim LC

SUSPENSION / COLGANTE  
IP20

**MATERIAL**

Acoustic panel, glass and polyester /  
Panel acústico, cristal y poliéster

**FINISH / ACABADO**

Acoustic panel / Panel acústico:  
Marbled grey, beige and terracotta /  
Gris jaspeado, beige y teja  
Canopy / Florón:  
Matt black / Negro mate  
Polyester belt / Cinta poliéster:  
Black / Negro  
Spheres / Esferas:  
Matt opal glass / Cristal opal mate

**INSTALLATION / INSTALACIÓN**

5 x G9 LED 4W

SUSPENSION / COLGANTE  
IP20

**MATERIAL**

Acoustic panel, aluminium and polyester /  
Panel acústico, aluminio y poliéster

**FINISH / ACABADO**

Acoustic panel / Panel acústico:  
Marbled grey, beige and terracotta /  
Gris jaspeado, beige y teja  
Canopy / Florón:  
Matt black / Negro mate  
Polyester belt / Cinta poliéster:  
Black / Negro  
Spotlights / Focos:  
Matt black / Negro mate

**INSTALLATION / INSTALACIÓN**

5 x COB LED 5W UGR<13 (24°) CRI>92  
- 3000K 2500lm  
- 4000K 2500lm

P dim PUSH



# PAMPA

The essence of PAMPA is to provide an optimal environment in workspaces. It is designed to illuminate properly, while supporting the soundproofing of a space. Thanks to the sound-absorbing material, it reduces noise, and with UGR glare control technology, it ensures uniform light distribution, minimising disturbing reflections.

La esencia de PAMPA es proporcionar un entorno óptimo en espacios de trabajo. Se trata de un diseño ideado para iluminar adecuadamente, a la vez que sirve de apoyo a la insonorización de un espacio. Gracias al material fonoabsorbente consigue reducir el ruido, y con la tecnología de control de deslumbramiento UGR, garantiza una distribución de luz uniforme, minimizando los reflejos molestos.



PAMPA 34822 Redclay



PAMPA 34822 Concrete



PAMPA 34821 Stone



PAMPA 34821 Stone



**PAMPA**  
**REF. 34821**

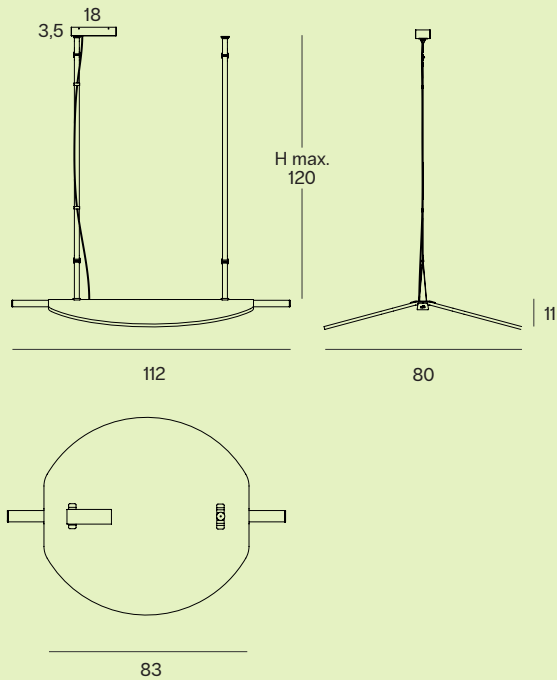

**PAMPA**  
**REF. 34822**

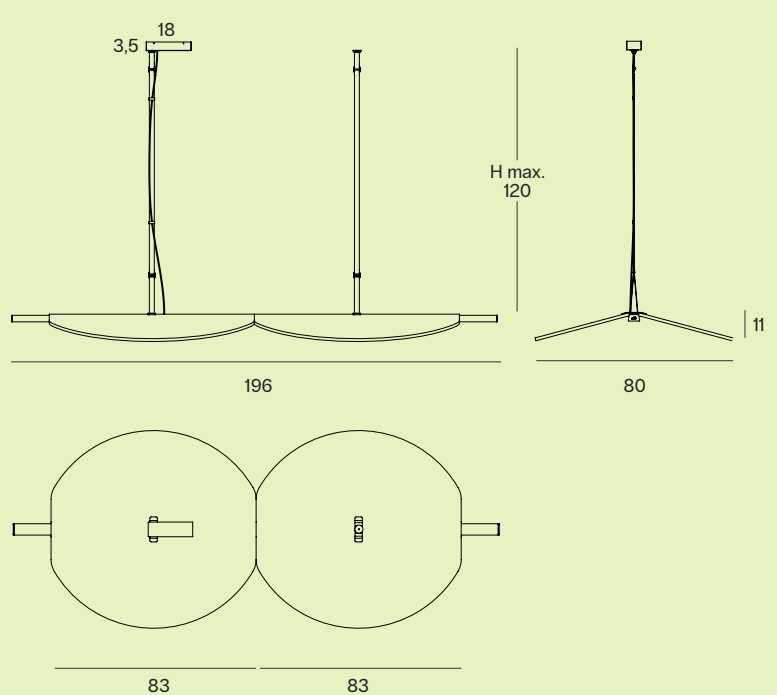

**SUSPENSION / COLGANTE**  
**IP20**

**MATERIAL**

Acoustic panel, aluminium, polycarbonate and polyester /  
Panel acústico, aluminio, policarbonato y poliéster

**FINISH / ACABADO**

Acoustic panel / Panel acústico:

Concrete, stone and redclay / Cemento, mazapán y arcilla

Profile / Perfil:

Matt black / Negro mate

Polyester belt / Cinta poliéster:

Black / Negro

Driver box / Caja driver:

Matt black / Negro mate

**INSTALLATION / INSTALACIÓN**

PCB LED 15W 400mA Optic system UGR<16 (65°) CRI>90

- 3000K 2420lm

- 4000K 2540lm

**SUSPENSION / COLGANTE**  
**IP20**

**MATERIAL**

Acoustic panel, aluminium, polycarbonate and polyester /  
Panel acústico, aluminio, policarbonato y poliéster

**FINISH / ACABADO**

Acoustic panel / Panel acústico:

Concrete, stone and redclay / Cemento, mazapán y arcilla

Profile / Perfil:

Matt black / Negro mate

Polyester belt / Cinta poliéster:

Black / Negro

Driver box / Caja driver:

Matt black / Negro mate

**INSTALLATION / INSTALACIÓN**

PCB LED 26W 700mA Optic system UGR<16 (65°) CRI>90

- 3000K 4235lm

- 4000K 4445lm

Ⓓ dim DALI   Ⓔ dim PUSH   Ⓒ dim Casambi

Ⓓ dim DALI   Ⓔ dim PUSH   Ⓒ dim Casambi

# KATANA

A practical and useful design in different areas. KATANA is a suspension that consists of an extruded aluminium profile with UGR and suspended by belt. In addition, it has a manual orientation system that allows to bathe walls. KATANA provides the right lighting and functionality both for work environments and for spaces dedicated to exhibitions, museums or art galleries.

Un diseño práctico y útil en diferentes ámbitos. KATANA es un colgante que consiste en un perfil de extrusión de aluminio con UGR y suspendido por cintas. Además, cuenta con un sistema manual de orientación que permite bañar paredes. KATANA aporta la iluminación y funcionalidad adecuadas tanto para entornos de trabajo, como para espacios dedicados a exposiciones, museos o galerías de arte.



KATANA 34021/112 34021/196



KATANA 34021/196

**KATANA**  
**REF. 34021/112**

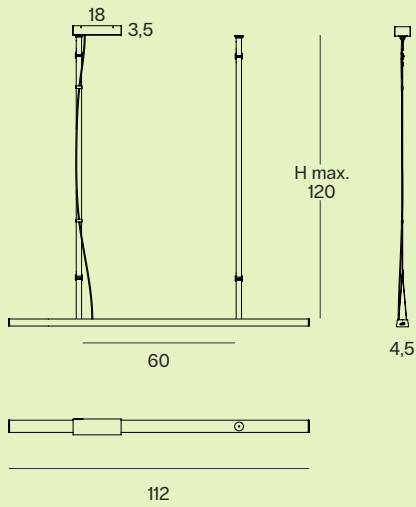

**KATANA**  
**REF. 34021/196**

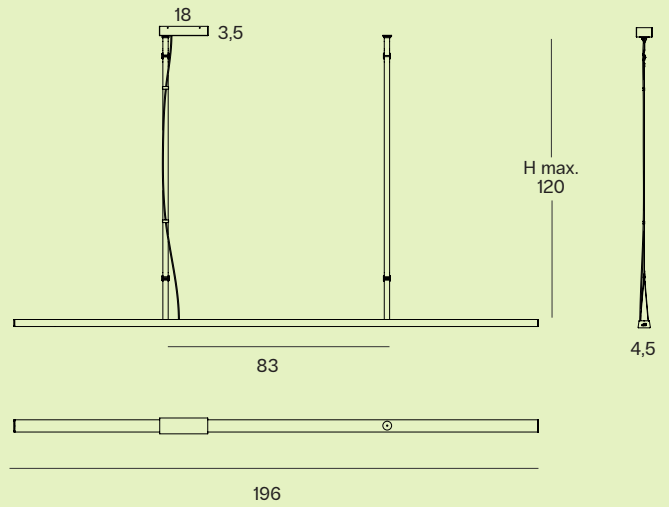

**SUSPENSION / COLGANTE**  
**IP20**

**MATERIAL**

Aluminium, polycarbonate and polyester /  
Aluminio, policarbonato y poliéster

**FINISH / ACABADO**

Driver box /Caja driver:

Matt black /Negro mate

Profile /Perfil:

Matt black /Negro mate

Polyester belt /Cinta poliéster:

Black /Negro

**INSTALLATION / INSTALACIÓN**

PCB LED 15W 400mA Optic system UGR<16 (65°) CRI>90

- 3000K 2420lm

- 4000K 2540lm

Ⓧ dim DALI   Ⓟ dim PUSH   Ⓞ dim Casambi

**SUSPENSION / COLGANTE**  
**IP20**

**MATERIAL**

Aluminium, polycarbonate and polyester /  
Aluminio, policarbonato y poliéster

**FINISH / ACABADO**

Driver box /Caja driver:

Matt black /Negro mate

Profile /Perfil:

Matt black /Negro mate

Polyester belt /Cinta poliéster:

Black /Negro

**INSTALLATION / INSTALACIÓN**

PCB LED 26W 700mA Optic system UGR<16 (65°) CRI>90

- 3000K 4235lm

- 4000K 4445lm

Ⓧ dim DALI   Ⓟ dim PUSH   Ⓞ dim Casambi

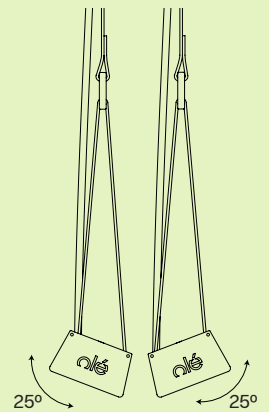

# ESTELA

Following the design line of the "wall to wall" system, ESTELA is a technical lighting solution designed for outdoor applications with IP67 rating, and a length of up to 10 metres. A versatile model that allows different arrangements both horizontally and vertically, tolerating an angle of up to 10° with the anchoring walls.

ESTELA is an ethereal line of light that extends elegantly in outdoor environments. Its minimalist design blends perfectly into any environment, creating an atmosphere where nature and modernity meet in harmony.

Siguiendo la línea de diseño del sistema "wall to wall", ESTELA es una solución de iluminación técnica para exterior con clasificación IP67 y una longitud de hasta 10 metros. Un modelo versátil que permite distintas disposiciones tanto en horizontal como en vertical, tolerando un ángulo de hasta 10° con las paredes de anclaje.

ESTELA es una línea de luz etérea que se extiende con elegancia en ambientes exteriores. Su diseño minimalista se fusiona perfectamente con cualquier entorno, creando una atmósfera donde la naturaleza y la modernidad se encuentran en armonía.



ESTELA 33010/10



ESTELA  
33010/4



ESTELA 33010/4



ESTELA **OUTDOOR**

REF. 33010/1 33010/2 33010/3 33010/4 33010/5 33010/6 33010/7 33010/8 33010/9 33010/10

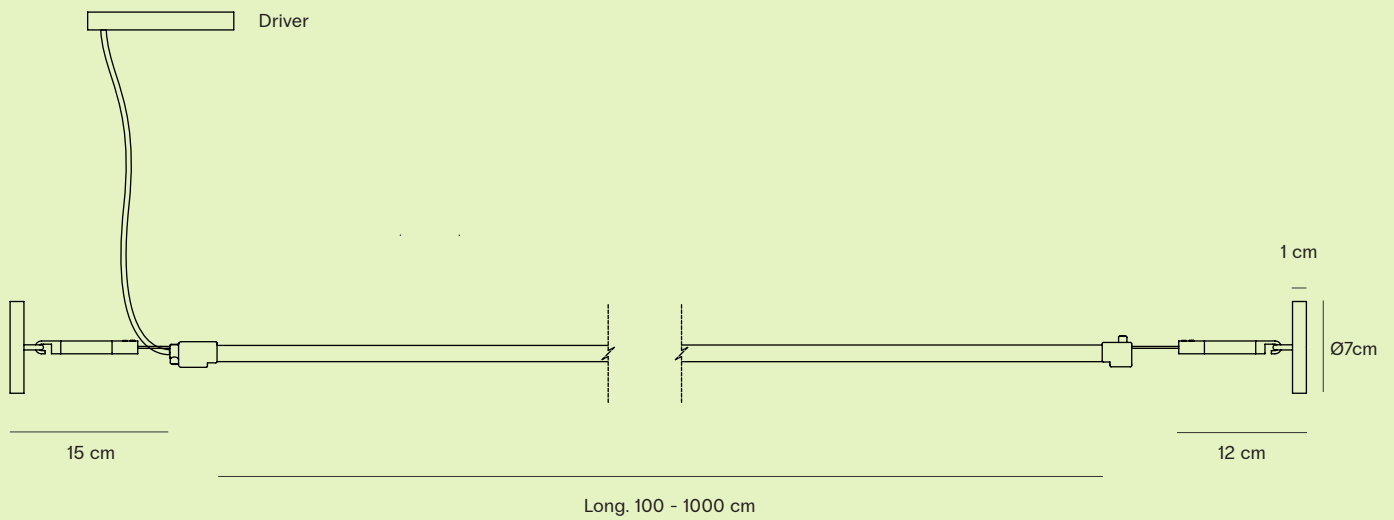
**WALL TO WALL**

IP67

**MATERIAL**

Aluminium, stainless steel and silicone / Aluminio, acero inoxidable y silicona

**FINISH / ACABADO**Profile / Perfil:

Black matt / Negro mate

Silicone difusser / Difusor silicona:

White / Blanco

Driver box / Caja driver:

No box / Sin caja

**INSTALLATION / INSTALACIÓN**

LED strip neon 24V 12W/m CRI &gt;90

- 2700K 562 lm

- 3000K 594 lm

Ⓟ dim 0-10V

Ⓒ dim Casambi



# HABE

Manex Bilbao Studio has designed HABE, the Basque word for "column". The designer was inspired by the elegance and solidity of these architectural pieces. This family of lamps meets history, creating a design that transcends time and highlights the eternal beauty of these structures. The light emanating through the cords is soft and enveloping, bringing life to any indoor or outdoor space.

Manex Bilbao Studio ha diseñado HABE, palabra vasca que significa "columna". Su diseñador se ha inspirado en la elegancia y solidez de estas piezas arquitectónicas. Esta familia de lámparas se encuentra con la historia creando un diseño que trasciende el tiempo y remarca la eterna belleza de estas estructuras. La luz que emana a través de las cuerdas es suave y envolvente, proyectando vida a cualquier espacio interior como exterior.

BY MANEX BILBAO STUDIO



HABE **ODIP33008/25L** Terracotta **ODIP33008/25** Beige **33001** Stone **33900/10** Cognac, Terracotta, Olive and Mocha

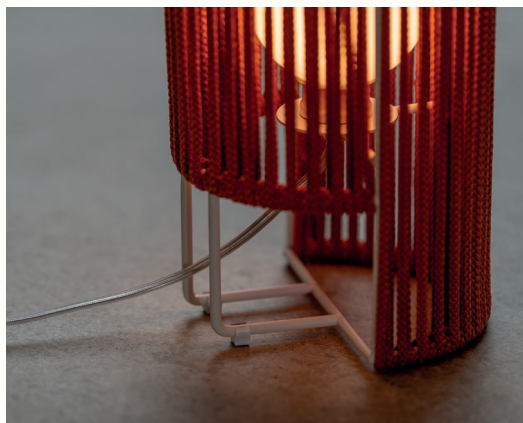

HABE  
33001 Terracotta



HABE 33001 Terracotta



HABE ODIP33008/25 Mocha ODIP33008/25L Beige



HABE 33900/10 Stone

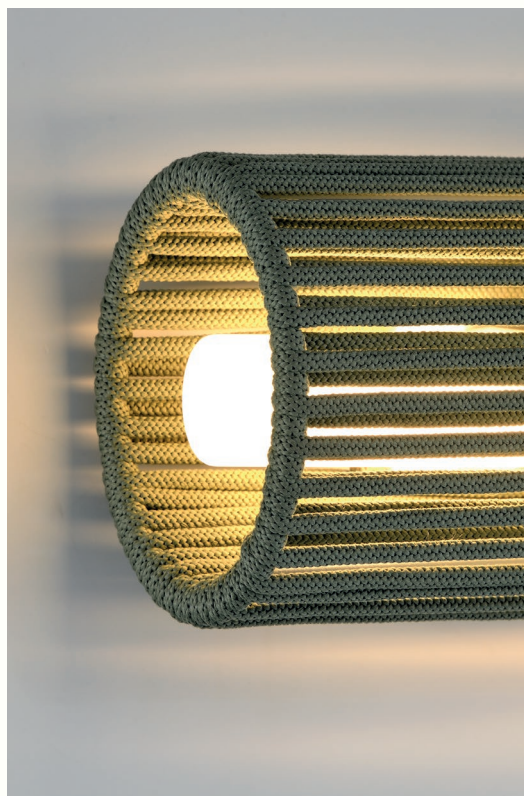

HABE  
33900/10 Olive

HABE  
REF. 33001

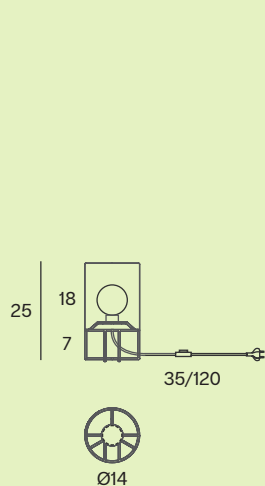

HABE **OUTDOOR**  
REF. ODIP33008/25

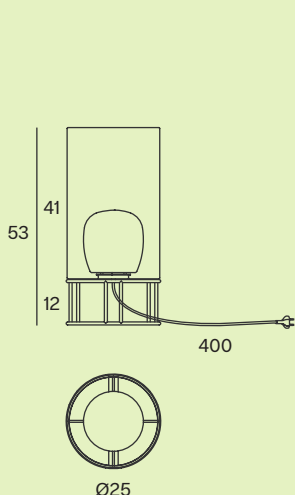

HABE **OUTDOOR**  
REF. ODIP33008/25L

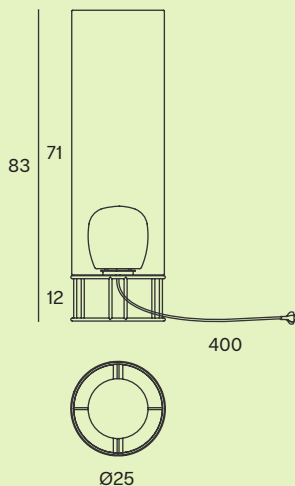

HABE  
REF. 33900/10

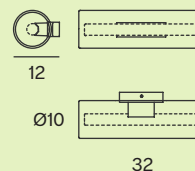

**TABLE LAMP / SOBREMESA**  
**IP20**

**MATERIAL**

Metal and recycled cord /  
Metal y cuerda reciclada

**FINISH / ACABADO**

Metal structure/Estructura metal:  
Granulated White / Blanco texturado  
Cord/Cuerda:  
See color chart/Ver carta de colores  
Glass difusser/Difusor cristal:  
Matt opal / Opal mate  
Plug and cable/Clavija y cable:  
Transparent / Transparente

**INSTALLATION / INSTALACIÓN**

1 x G9 LED 4W

**FLOOR LAMPS / PIES**  
**IP66**

**MATERIAL**

Metal and recycled cord / Metal y cuerda reciclada

**FINISH / ACABADO**

Metal structure/Estructura metal:  
Granulated White / Blanco texturado  
Cord/Cuerda:  
See color chart/Ver carta de colores  
Polyethylene difusser/Difusor polietileno:  
Matt opal / Opal mate  
Plug and neoprene cable/Clavija y cable neopreno:  
Black neoprene / Neopreno negro

**INSTALLATION / INSTALACIÓN**

1xE27 LED max. 15W Ø6cm

**WALL LAMP / APLIQUE**  
**IP20**

**MATERIAL**

Metal and recycled cord /  
Metal y cuerda reciclada

**FINISH / ACABADO**

Base:  
White / Blanco  
Metal structure/Estructura metal:  
White / Blanco  
Cord/Cuerda:  
See color chart/Ver carta de colores

**INSTALLATION / INSTALACIÓN**

1 x S14d LED max. 5W L30cm

# Color chart

## OCEANS WITHOUT PLASTIC

Since we started in 2022 until the end of 2023, we have recycled a total of 13,176 kg of plastic with our cord lamps. Thanks to our customers for making this initiative possible.

Desde que empezamos en 2022 hasta finales de 2023, hemos reciclado un total de 13.176 kg de plástico con nuestras lámparas de cuerda. Agradecemos a nuestros clientes haber hecho posible esta iniciativa.



## Standard colours of recycled cord (indoors & outdoors use) Colores estándar de cuerda reciclada (uso interior y exterior)

 <p><b>1196</b> Stone / Mazapán Pantone 7582C</p>	 <p><b>71</b> White / Blanco Pantone White</p>	 <p><b>61</b> Blue / Indigo Pantone 653C</p>
 <p><b>196</b> Beige Pantone 727C</p>	 <p><b>323</b> Olive / Oliva Pantone 5625C</p>	 <p><b>129</b> Silver / Plata Pantone COOL GRAY 7C</p>
 <p><b>168</b> Mustard / Mostaza Pantone 1245C</p>	 <p><b>301</b> Dark green / Alga Pantone 5615C</p>	 <p><b>120</b> Grey / Gris Pantone COOL GRAY 10C</p>
 <p><b>205</b> Terracotta / Teja Pantone 153C</p>	 <p><b>175</b> Mocha / Dromedario Pantone 7504C</p>	 <p><b>211</b> Black / Negro Pantone BLACK C</p>
 <p><b>224</b> Maroon / Granate Pantone 1955C</p>	 <p><b>255</b> Cognac / Coñac Pantone 181C</p>	



Special colours (for indoor use only)  
Colores especiales (solo para uso interior)



**75 Cristal**  
Pantone GLASS



**1401 Alpaca**  
Pantone 429C



**2621 Litio**  
Pantone 5425C



**126 Delfin**  
Pantone 430C



**169 Tunel**  
Pantone BLACK 7C



**1786 Boreal**  
Pantone 7547C



**66 Nocturno**  
Pantone 7547C



**63 Marino**  
Pantone 289C



**68 Pacific**  
Pantone 2767C



**125 Alitalia**  
Pantone 646C



**24 Medas**  
Pantone 295C



**1075 Azul Royal**  
Pantone 288C



**67 Oceano**  
Pantone 294C



**49 Azul Electrico**  
Pantone 2945C



**55 Tejano**  
Pantone 3015C



**59 Blavina**  
Pantone 2915C



**60 Escarcha**  
Pantone 2707C



**313 Lago**  
Pantone 324C



**317 Green**  
Pantone 326C



**311 Jade**  
Pantone 3268C



**353 Verde Billar**  
Pantone 340C



**310 Jungla**  
Pantone 356C



**358 Verde Oscuro**  
Pantone 3298C



**320 Musgo**  
Pantone 5535C



**104 Ciruela**  
Pantone 368C



**2214 Lavanda**  
Pantone 374C



**170 Crudo**  
Pantone 7401C



**1442 Opale**  
Pantone 402C



**101 Astracan**  
Pantone 7529C



**161 Camello**  
Pantone 731C



**1674 Castaño**  
Pantone 4625C



**203 Tabaco**  
Pantone 1545C



**187 Marron**  
Pantone 476C



**189 Marron Super**  
Pantone BLACK 4C



**2183 Madera**  
Pantone 7519C



**152 Avellana**  
Pantone 729C



**151 Arena**  
Pantone 465C



**154 Camel**  
Pantone 1265C



**16 Oro**  
Pantone 872C



**7 Golden**  
Pantone 7403C



**9 Canario**  
Pantone 106C



**15 Mimosa**  
Pantone 108C



**1 Amarillo**  
Pantone 109U



**1871 Nectar**  
Pantone 137C



**1334 Lava**  
Pantone 151C



**87 Naranja**  
Pantone 164C



**84 Calabaza**  
Pantone 158C



**150 Arcilla**  
Pantone 1675C



**241 Rojo**  
Pantone 186C



**245 Fuego**  
Pantone 185C



**19 Satan**  
Pantone 207C



**240 Clarete**  
Pantone 209C



**163 Burdeos**  
Pantone 188C



**285 Rubina**  
Pantone 229C



**273 Fresilla**  
Pantone 695C



**276 Purpura**  
Pantone 215C



**264 Ciclamor**  
Pantone 205C



**267 Fucsia**  
Pantone 212C



**275 Pesca**  
Pantone 218C



**281 Rosa Pastel**  
Pantone 1905C



**261 Alejandria**  
Pantone 196C



**43 Canet**  
Pantone 2717C



**141 Malva**  
Pantone 2567C



**135 Amaratado**  
Pantone 265C



**62 Lapislazuli**  
Pantone 2745C



**147 Violeta**  
Pantone 7676U

**Acoustic finishes**  
Acabados acústicos



Stone / Mazapán



Beige

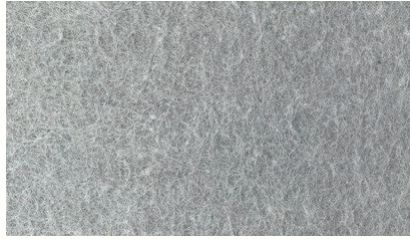

Concrete / Cemento



Marbled grey / Gris jaspeado

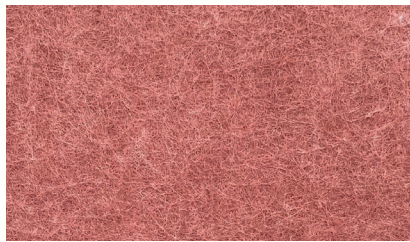

Redclay / Arcilla



Terracotta / Teja

## CONDITIONS, GUARANTEE AND MAINTENANCE

FM ILUMINACIÓN, S.L.U. reserves the right to make any changes it believes are beneficial to the products of the present catalogue., with the aim to improve the characteristics, safety or lighting applications.

### GUARANTEE

Manufacturer guarantees the proper functioning of this equipment, repairs or spare parts of the model owing to faulty manufacture during 3 years after the surrender date. Responsibility will not be accepted, however, for damages or injury caused through misuse.

### FABRIC LUMINAIRES MAINTENANCE

Clean the metal frame before placing the fabric. In case the fabric is wrinkled, iron it before placing it. To wash the fabric separately with neutral soaps and cool water. Spare fabrics available for all models.

### TECHNICAL INFORMATION: Dimmable drivers for LED

**(V) Analogical regulation system 0-10V:** By means of a potentiometer connecting two wires to the DRIVER, it transmits a signal that goes from 0 to 10V. Being 0V off and 10V the maximum brightness

**(P) PUSH Regulation system:** Light intensity regulation occurs through the use of a "normally open" type push button and it is the easiest type of regulation available on the market, only one push button for regulation (turn off with a rapid pulse, and is regulated by a long pulsation), only one wire from de push button to the driver

**(D) Digital regulation system DALI:** This interface has been jointly developed by the most important producers of electronic driver s to create a standard regulation for the lighting engineering industry all over the world.

**(R) Remote control regulation system:** The radio remote control management system utilizes electromagnetic waves to transmit the signals. Dimmable Kelvins and Power.

**(LC) Leading & Trailing-edge dimming LC:** This type of controlling is accomplished without any need for an additional control wire. It involves connecting a dimmer in series between one of the mains wire and the equipment

**(C) Casambi regulation system:** Casambi dimming is advanced wireless technology for controlling lighting systems via Bluetooth, available for smartphones, tablets and smartwatches. In case of installations with light bulbs, these must be dimmable

## CONDICIONES, GARANTÍAS Y MANTENIMIENTO

FM ILUMINACION, S.L.U. se reserva el derecho de efectuar modificaciones en los modelos del presente catálogo, con el fin de mejorar sus características de diseño, su seguridad o sus funciones luminotécnicas..

### GARANTÍA

El fabricante entrega junto a los equipos una garantía que asegura el correcto funcionamiento del equipo y posibles reparaciones o suministro de recambios del modelo debidos a defectos de fabricación durante 3 años desde la fecha de entrega. Se excluyen consumibles como telas elásticas, bombillas... que será de 2 años.

### MANTENIMIENTO DE LUMINARIAS DE TELA

Antes de colocar la tela, limpiar la estructura metálica, para su colocación utilizar los guantes que se incorporan. En caso de que la tela quede algo arrugada, la puede planchar antes de colocarla. Lavar la tela por separado, utilizar jabones neutros y agua fría. Disponemos de telas de recambio para todos los modelos.

### INFORMACIÓN TÉCNICA: Drivers Regulables LED

**(V) Regulación analógica de 0-10V:** Mediante un potenciómetro conectando dos hilos al DRIVER, transmite una señal que va de 0 a 10V. Siendo 0V apagado y 10V el máximo de luminosidad.

**(P) Regulación PUSH:** La regulación se produce a través de un pulsador normalmente abierto, que mediante un solo hilo conectado al DRIVER desde el pulsador, regula la intensidad de luz, además permite su apagado completo mediante una pulsación rápida, y se regulamediante una pulsación larga que sube o baja la intensidad alternativamente

**(D) Regulación DALI:** Mediante el estándar de regulación digital DALI (Digital Addressable Lighting Interface). Controlado mediante una centralita, permite un control total de la instalación, memorizar escenarios de luz, etc.

**(R) Regulación Remota:** La regulación se realiza mediante un mando a distancia, que nos permite controlar la temperatura de color de la luz (en grados Kelvin) o su intensidad.

**(LC) Regulación por corte de fase:** La regulación se realiza mediante un regulador de corte al inicio y/o al final de fase. No necesita hilos adicionales dirigidos al DRIVER, ya que es un regulador en serie colocado entre la línea de alimentación y el DRIVER.

**(C) Regulación Casambi:** La regulación Casambi consiste en tecnología inalámbrica avanzada para controlar sistemas de iluminación a través de bluetooth, disponible para smartphones, tablets y smartwatch. En el caso de instalaciones con bombillas, estas han de ser regulables.

## QUALITY GUARANTEE AND CORPORATE SOCIAL RESPONSIBILITY

Our aim is to provide the best quality both to our products and our services, trying to achieve maximum customer satisfaction, this objective is backed by AENOR and its quality stamps we have got. Our Corporate Social Responsibility is based on the active and voluntary contribution to social, economic and environmental improvement for which we collaborate with prestigious NGOs such as "Medecins Sans Frontieres" and others that do a more modest but important work, such as "Creer en ellas", which seeks to respond to a daily reality of violence and vulnerability suffered by young women and adolescents in the D.R. Congo. Our human team is working with the highest respect for the environment, improving our production processes and above all we promote energy saving. It's our commitment to a solid work ethic, integrity and honesty.

## SELLOS DE CALIDAD Y RESPONSABILIDAD SOCIAL CORPORATIVA

Nuestro objetivo es proporcionar la mejor calidad tanto a nuestros productos como a nuestros servicios, intentando conseguir la máxima satisfacción al cliente, nos avalan los sellos de calidad AENOR. Nuestra Responsabilidad Social Corporativa está basada en la contribución activa y voluntaria al mejoramiento social, económico y ambiental para lo cual colaboramos con ONGs, algunas de reconocido prestigio como "Médicos Sin Fronteras" y otras que hacen una labor más modesta pero importante, como "Creer en ellas," que busca dar respuesta a una realidad cotidiana de violencia y vulnerabilidad que sufren jóvenes y adolescentes en la R.D del Congo. Nuestro equipo humano trabaja con el máximo respeto hacia el medioambiente, mejorando nuestros procesos productivos con ese fin y, sobre todo, promovemos el ahorro energético. Es nuestro compromiso con una sólida ética laboral, integridad y honestidad.

### CREDITS

#### Photos

Juanjo Aviñó | Studios Aviñó  
Carlos Martí | Dsigno studio

#### Printed by

Logik Graphics

#### Mock up

Brandom





Thank you for being part of the Olé Family

Fernando Martínez  
Owner and Head of Design



**FM Iluminación S.L.U**

C/ Germanías, 12-14, Pol. Ind El Pou

46960 Aldaia, Valencia, SPAIN

T.+34 961 515 977

[info@ole-lighting.com](mailto:info@ole-lighting.com)

Whatsapp: +34 657 979 510

**Direct Export**

Tel: +34 655 917 238

[export@ole-lighting.com](mailto:export@ole-lighting.com)



