



VANGUARD LED DISPLAYS



Tungsten

Production & News Set DISPLAYS

VANGUARD LED DISPLAYS



Visit our site to
learn more!

Production Displays

- **Broadcast-Grade Visual Performance:** Fine pixel pitch and flicker-free refresh rates optimized for studio cameras and live feeds.
- **Seamless exceptional DCI-P3 Color Accuracy:** True-to-life color calibration across the full display surface, ideal for chroma keying and post-production
- **Low Heat & Silent Operation:** Fan-less designs with efficient thermal management for quiet studio environments
- **Flexible Mounting & Custom Sizing:** Designed for integration into curved, flat, or creative set elements with precision alignment

Vanguard LED Displays brings high-performance visual technology to the fast-paced world of production studios and live broadcast environments. From national newsrooms and weather centers to entertainment stages and talk shows, our LED solutions deliver the clarity, control, and reliability that today's media professionals require.

Engineered with fine pixel pitches, high refresh rates, and exceptional DCI-P3 color accuracy, Vanguard LED walls are built to perform under studio lighting and in front of high-resolution cameras. Whether used as immersive scenic backdrops or dynamic storytelling canvases, our displays eliminate flicker, moiré, and ensure every frame captures your visual intent.

Our panels are designed for silent operation, which maintain optimal performance without compromising the quiet on set. Seamless integration options—including wall-mounted, floor-supported, and curved configurations—make Vanguard LED displays a favorite among set designers and broadcast engineers alike.

When the red light goes on, there's no room for error. Vanguard delivers professional-grade video display technology trusted by studios, streaming services, and news networks across the country—because in live production, "good enough" isn't good enough.





Tungsten

- 500 x 500mm panel
- 500 x 1000mm panel
- Panel-to-panel **curving**
- Integrated **corner protection**



Cesium

- **Integrated panel curving** up to 45° concave or convex
- 500 x 500 mm panel
- Compatible with **Tungsten** panels
- Integrated **corner protection**



Zirconium

- Design in **250mm** units
- **1.9 - 5.2mm** pitch range
- **6** unique panel frame sizes
- **Universal modules** for all panel sizes



Houdini transparent

Invisible curtain

- Up to **5000 nits**
- Up to **90% transparency**
- **1.8mm** total thickness
- **2.5 - 6.3mm** pitch range
- **Repairable** using same technique as standard SMD



Visit our site to learn more!



pitch	1.5	1.9	2.6	3.9
pixel tech	IMD	SMD	SMD	SMD

ideal for

Indoor rental and production

summary

Tungsten is an excellent choice for most rental applications with a stout 500x500mm and 500x1000 mm panel, combined with fine-pitch options typically only seen with fixed installation products.

Tungsten has column-to-column curving options up to -6 degrees to +6 degrees. Column-to-column curving set by a rotating bracket with fixed angles, reducing the need to precisely set an angle for every panel. Panels feature a flip-out metal shield which protects the corner pixels during handling, reducing damages.

special configurations



optional

- Epoxy masking or coating
- Protective/cosmetic edge trim
- Flight cases
- Alternate column-to-column angle brackets

Tungsten

dimensions

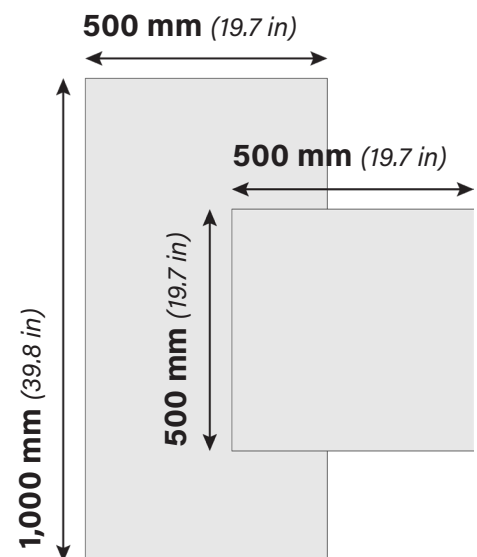

max brightness
1,200 nits

IP rating
IP30



Standard: $\pm 3^\circ/0/+6^\circ$

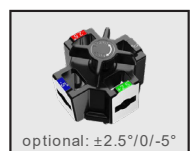

Tungsten

SERIES NAME

MAXIMUM BRIGHTNESS (NITS)	up to 1,000	
DIMENSIONS	WIDTH	500 mm (19.7 in)
	HEIGHT	up to 1000 mm (39.4 in)
	DEPTH	72.5 mm (2.9 in)
PANEL ASPECT RATIO	0.5:1, 1:1	
PANEL WEIGHT	8 kg (17.6 lbs)	
MODULES PER PANEL	up to 8 per panel	
VIEWING ANGLE	HORIZONTAL	160°
	VERTICAL	160°
LED LIFETIME* (HRS)	50,000	
CONTRAST	8,000:1	
DRIVERS	ICN1065, ICN1069, ICN2055 (depending on pitch)	
SCAN RATE	1/16	
PROCESSING DEPTH (BITS)	14 default (8~14 range)	
REFRESH RATE (HZ)	7,680 default (7,680 range)	
FRAME RATE	60 default (60 options)	
COLOR TEMPERATURE	8,500 default (2000-9300 range)	
COLOR GAMUT	2.8(1.0 - 4.0)	
BONDING WIRE	Copper	
POWER COMMON	Anode, cathode (depending on pitch)	
WATTS PER PANEL	150-400W max (53-140W average)	
WATTS PER SQ M	600-800W max (210-280W average)	
MAX AMPS PER CASCADE	20	
OPERATING VOLTAGE	100-240V AC, 50/60 Hz	
OPERATING TEMPERATURE	-20°C - +50°C	
MAXIMUM HEAT	513-1,367 BTU/hr (depending on pitch and panel size)	
HUMIDITY	10% - 90%, non-condensing	
IP RATING	IP30	
FRAME MATERIAL	Die-cast Aluminium	
HANGING AND STACKING	no hanging no stacking	
REAR BOLT THREADING	M10	
POWER CONNECTORS	Seetronic Powercon	
DATA CONNECTORS	Seetronic Ethercon	
SERVICE ACCESS	Front and Rear	
WARRANTY	3 year (up to 5 available)	
CERTIFICATIONS	EMC-A, CCC, FCC, ETL, LVD, CE, RoHS, UKCA, CB, BIS, KC, PSE	

**the above specifications reflect a standard configuration of the modules and panels*

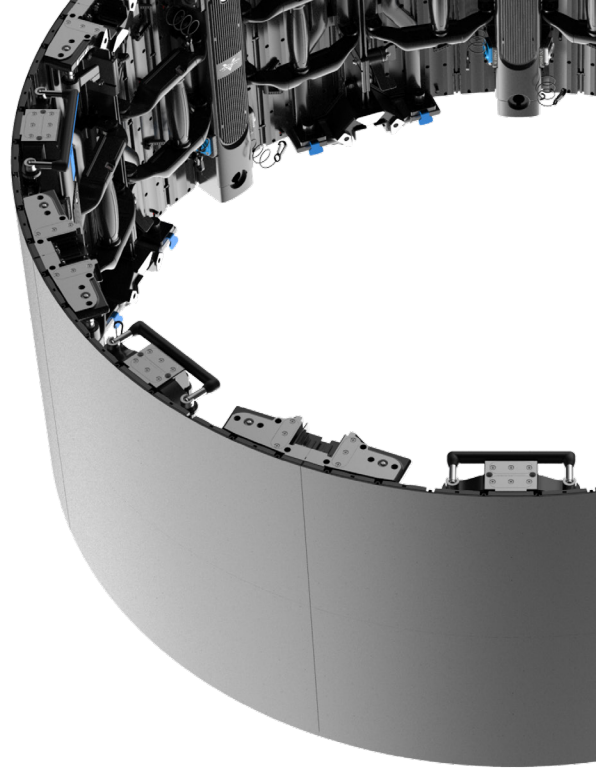

Cesium

pitch

1.9

2.6

pixel tech

SMD

SMD



Cesium



Tungsten

Compatible with Tungsten



ideal for

Indoor rental and production

summary

Cesium series expands design potential with dynamically curving panels. Integrated handles on the rear are used for carrying and adjusting the internal curve of the panel. An individual Cesium panel can achieve up to a 45-degree curve, concave or convex. Create a perfect cylinder as narrow as 1.3 meters (4.2 ft).

Sixteen (16) panels can create a complete 360-degree circle.

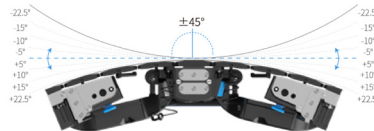

Like Tungsten, Cesium panels feature metal corner protectors which fold closed and deploy via spring and push of a button on the rear of the panel.

special configurations



optional

- Epoxy masking or coating
- Connecting plates
- Flight cases
- Headers for hanging/flying
- Footers for stacking
- Reduced magnets for transit stations
- Hydrophobic module treatment

dimensions

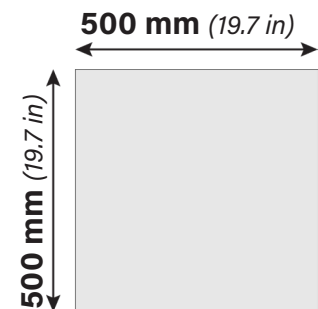

aspect ratio

1:1

weight

8 kg (17.6 lbs)

max brightness

1,500 nits

IP rating

IP30

Cesium

SERIES NAME	up to 900	
MAXIMUM BRIGHTNESS (NITS)	up to 900	
DIMENSIONS	WIDTH	500 mm (19.7 in)
	HEIGHT	500 mm (19.7 in)
	DEPTH	73 mm (2.9 in)
PANEL ASPECT RATIO	1:1	
PANEL WEIGHT	8 kg (17.6 lbs)	
MODULES PER PANEL	4 per panel	
VIEWING ANGLE	HORIZONTAL	160°
	VERTICAL	160°
LED LIFETIME* (HRS)	50,000	
CONTRAST	8,000:1	
DRIVERS	ICN2055	
SCAN RATE	1/32	
PROCESSING DEPTH (BITS)	14 default (8-14 range)	
REFRESH RATE (HZ)	3,840 default (3,840 range)	
FRAME RATE	60 default (50, 60 options)	
COLOR TEMPERATURE	8,500 default (2000-9300 range)	
COLOR GAMUT	2.8 (1.0 - 4.0)	
BONDING WIRE	Copper	
POWER COMMON	Anode	
WATTS PER PANEL	150-200W max (53-70W average)	
WATTS PER SQ M	600-800W max (210-280W average)	
MAX AMPS PER CASCADE	20	
OPERATING VOLTAGE	100-240V AC, 50/60 Hz	
OPERATING TEMPERATURE	-20°C - +50°C	
MAXIMUM HEAT	513-683 BTU/hr (depending on pitch and panel size)	
HUMIDITY	10% - 90%, non-condensing	
IP RATING	IP30	
FRAME MATERIAL	Die-cast Aluminium	
HANGING AND STACKING	20 hanging max 20 stacking max	
REAR BOLT THREADING	M10	
POWER CONNECTORS	Seetronic Powercon	
DATA CONNECTORS	Seetronic Ethercon	
SERVICE ACCESS	Front and Rear	
WARRANTY	3 year (up to 5 available)	
CERTIFICATIONS	EMC-A, CCC, FCC, ETL, LVD, CE, RoHS, UKCA, CB, BIS, KC, PSE	



Visit our site to learn more!



Zirconium

pitch	1.9	2.6	3.1	3.9	5.2
pixel tech	SMD	SMD	SMD	SMD	SMD

ideal for

Unique shapes and non-standard aspect ratios

summary

Zirconium is a freeform series that enables configuration in units of 250mm both vertically and horizontally. Zirconium has three panel widths and two heights. Panel sizes are used dynamically to get extremely close to any target dimensions. All panels use the same, interchangeable modules.

Zirconium panels can be edge-chamfered to 45 degrees on either the left side, right side, or both. This allows Zirconium to make faceted convex curves or outside 90-degree corners.

special configurations



optional

- Protective edge trim
- 45-degree edges for corners
- Connecting plates
- Reduced magnets for transit stations
- Dual receiving cards for data redundancy
- Hydrophobic treatment
- Flight cases

panel dimensions

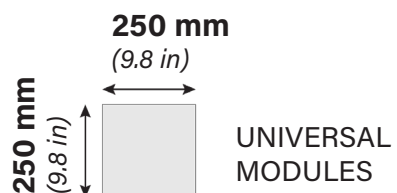
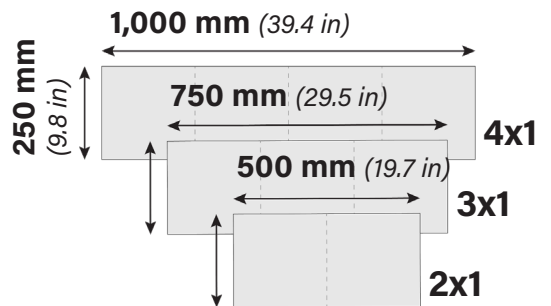
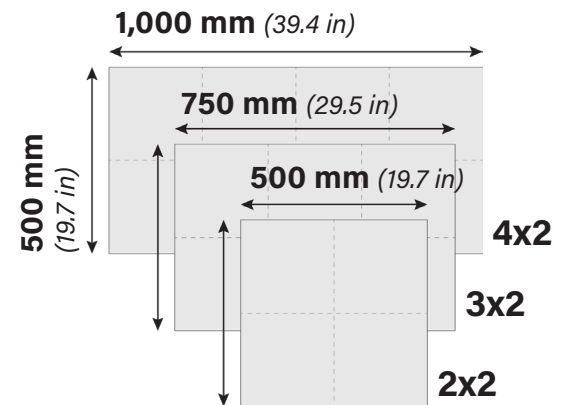

IP rating
IP30

max brightness
1,000 nits

Zirconium

SERIES NAME

MAXIMUM BRIGHTNESS (NITS)	up to 1,000	
DIMENSIONS	WIDTH	up to 1000 mm (39.4 in)
	HEIGHT	up to 500 mm (19.7 in)
	DEPTH	42 mm (1.7 in)
PANEL ASPECT RATIO	1.5:1, 1:1, 2:1, 3:1, 4:1	
PANEL WEIGHT	up to 11 kg (24.3 lbs)	
MODULES PER PANEL	up to 8 per panel	
VIEWING ANGLE	HORIZONTAL	160°
	VERTICAL	160°
LED LIFETIME* (HRS)	50,000	
CONTRAST	8,000:1	
DRIVERS	ICN2055, ICN2150, ICN2165 (depending on pitch)	
SCAN RATE	1/16, 1/32, 1/64 (depending on pitch)	
PROCESSING DEPTH (BITS)	14 default (8-16 range)	
REFRESH RATE (HZ)	3,840 default (3,840 range)	
FRAME RATE	60 default (60 options)	
COLOR TEMPERATURE	8,500 default (2000-9300 range)	
COLOR GAMUT	1.0 - 4.0	
BONDING WIRE	Copper	
POWER COMMON	Anode	
WATTS PER PANEL	59-290W max (21-102W average)	
WATTS PER SQ M	475-580W max (166-203W average)	
MAX AMPS PER CASCADE	20	
OPERATING VOLTAGE	100-240V AC, 50/60 Hz	
OPERATING TEMPERATURE	-20°C - +50°C	
MAXIMUM HEAT	203-991 BTU/hr (depending on pitch and panel size)	
HUMIDITY	10% - 90%, non-condensing	
IP RATING	IP30	
FRAME MATERIAL	Die-cast Aluminium	
HANGING AND STACKING	no hanging no stacking	
REAR BOLT THREADING	M6	
POWER CONNECTORS	C13/C14	
DATA CONNECTORS	RJ45	
SERVICE ACCESS	Front	
WARRANTY	3 year (up to 5 available)	
CERTIFICATIONS	EMC-B, CCC, FCC, ETL, LVD, CE, RoHS, UKCA, CB, BIS, KC, PSE	



Invisible curtain with a high resolution and vibrant display

Visit our site to learn more!

Houdini transparent

Invisible curtain

pitch	2.5	3.9	6.3
pixel tech	SMD	SMD	SMD

ideal for

Transparent hanging or window-mounted displays

summary

Vanguard's Houdini represents the next-generation of transparent LED display. With pitches from 2.5 up to 6.3mm, Houdini is suitable for viewers near and far. Each pixel contains its own driver so there is no scan rate and no refresh rate!

Featuring a soft and flexible fiberglass PCB, Houdini panels can be hung or adhered to either side of glass. With up to 90% rated transparency and no rear supporting structure, Houdini is nearly invisible from behind and allows clear visibility through the display.

Panels can interlock using invisible splicing and can be trimmed to exact size and so displays can be configured to completely fill almost any size space. With up to 5000 nit maximum brightness, Houdini is ideal for exterior facing windows.

optional

- Vertical or horizontal mounting
- Rear adhesive (for front of glass mounting)
- Front adhesive (for behind glass mounting)



dimensions

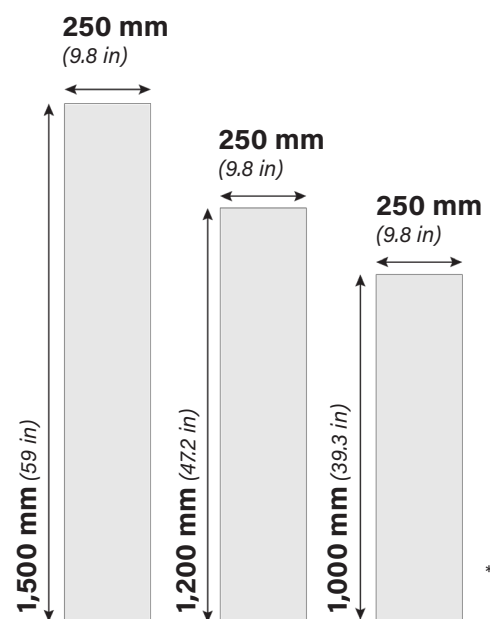

* 2.5mm panels are 125mm (4.9in) wide.

max brightness
5,000 nits

IP rating
IP20



hanging

Houdini can be hung and displayed without being mounted to glass. In this application air can pass freely through the display.

Configure a visually stunning open-air display with all the richness of a standard LED display. When configured for hanging, displays can either be a maximum of 3 meters wide or 3 meters tall with no structure of any kind behind the pixels.!

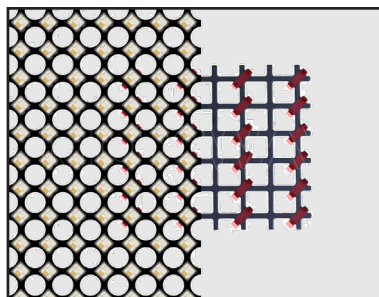

Houdini panels are spliced together using a special connection piece which does not interfere with the transparency of the display. When installed, the splices are nearly invisible, unless viewed from behind the display and only at certain angles.





behind glass



Houdini modules can be directly adhered to the back side of the glass, with the LEDs shining through the glass.

This application is ideal for retail applications where the display is physically inside the store while the display is only visible from outside.

With a maximum brightness of 5000 Nits (6.3mm), Houdini works well for exterior-facing windows.

The film adhesion to the glass is not permanent. If module repair is needed, individual modules can be removed, serviced, and re-installed.

in front of glass

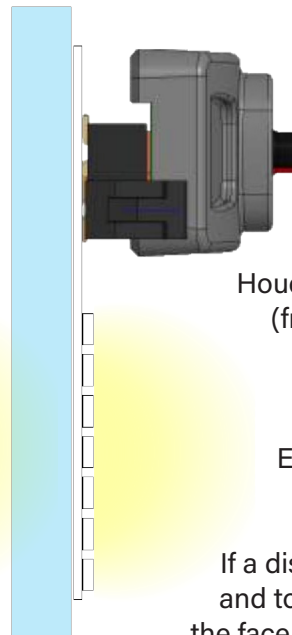

Houdini modules can also be adhered (from the rear of the module) to the front side of the glass, having the LEDs shine away from the glass.

Each individual Houdini model has a unique transparency level.

If a display cannot be directly accessed and touched by the public, installing on the face of the glass produces wider clear viewing angles as the audience is not looking through the depth of the glass to see the image.

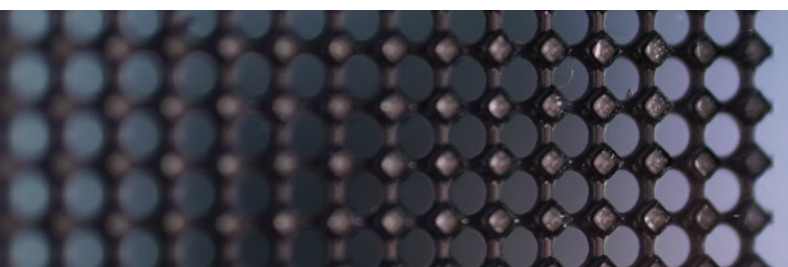

The above image shows Houdini mounted behind glass (LEFT) and in front of glass (RIGHT).

panel configurations

	2.5mm	3.9mm	6.3mm
TRANSPARENCY	70%	80%	90%
MAXIMUM BRIGHTNESS	1,200 Nits	3,000 Nits	5,000 Nits
MODULE WIDTH	125 mm	250 mm	250 mm
MODULE HEIGHT	1,500 mm	1,500 mm	1,500 mm

6.3mm

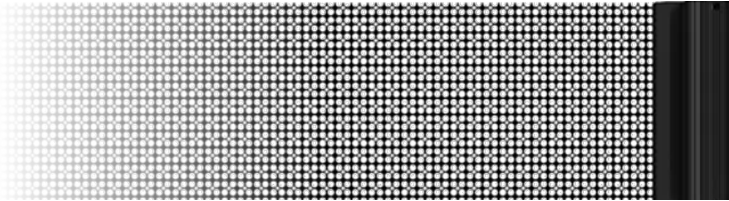

3.9mm

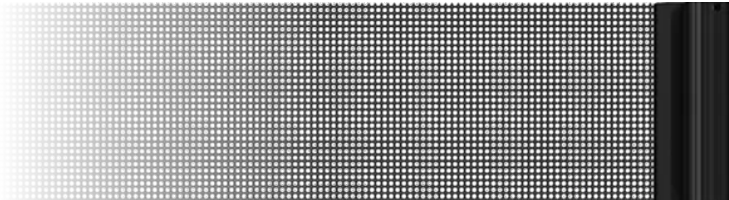

2.5mm

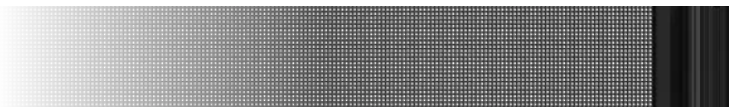

general specifications

LED half-life*	100,000 hours
REFRESH RATE	3,840 Hz
FRAME RATE	50, 60, 120 Hz
COLOR TEMPERATURE	6,500 K default (3,000 - 9,000 K range)
PROCESSING DEPTH	Up to 16 bits
SCAN RATE	No scan rate! Static integrated IC drivers
TEMPERATURES	-20°C - +50°C
OPERATING HUMIDITY	20 - 85% RH, non-condensing
OPERATING VOLTAGE	100 - 240 V AC, 50/60 Hz
MAXIMUM WATTS	1,000 W / SqM
IP RATING	IP20
MAXIMUM HEAT	3,410 BTU/hr/SqM
SERVICE ACCESS	Front
WARRANTY	3-year default (up to 5-year available)
CERTIFICATIONS	EMC, ISO, CCC, ICC, CB, FCC, CE, ETL, RoHS



Houdini panels can be cut to the exact length to perfectly fit most applications.

cathode and anode

COMMON ANODE

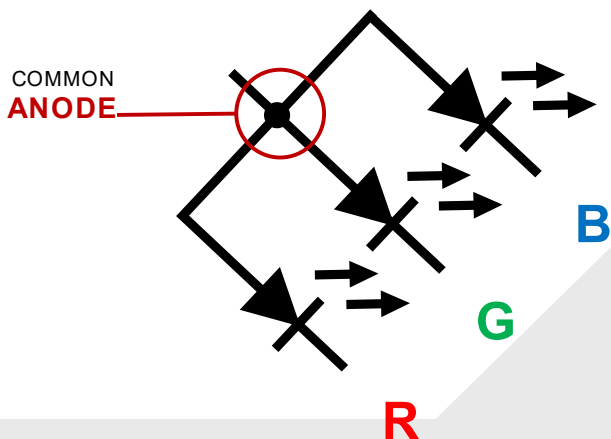

Full power into each sub-pixel

- **PRO** - Full range pixel performance
- **CON** - Significant heat and power inefficiency for G and B

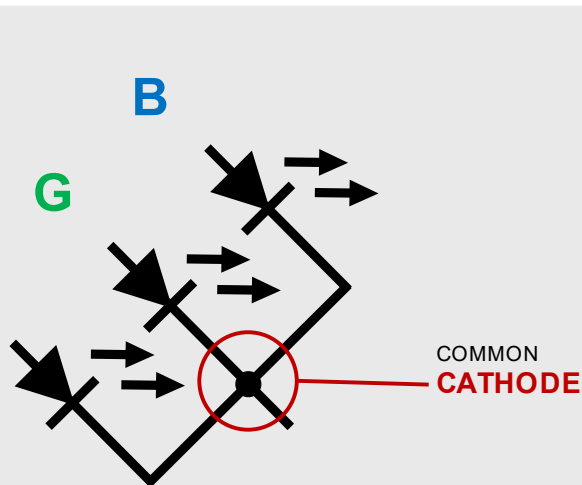

COMMON CATHODE

On-demand power into each sub-pixel

- **PRO** - Eliminated inefficiency for G and B resulting in much less heat dissipation from the display
- **CON** - Slight reduction in high-end range

LED diode/chip mounting

Flip-chip mounting

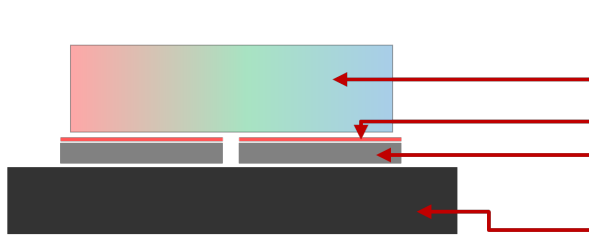

Standard mounting

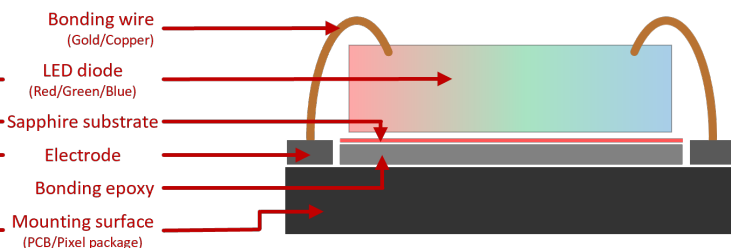

LED pixel protections

Directly on PCB with coating

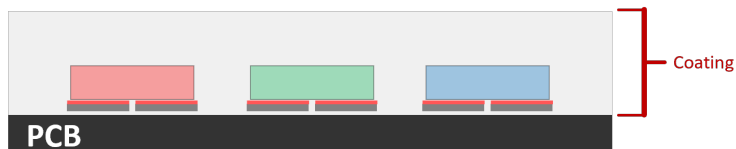

PIXEL TYPES: COB

- Diodes mounted directly to PCB
- Protective and potentially multi-layered coating in silicone or epoxy

Packaged/encapsulated



PIXEL TYPES: SMD, IMD, MIP

- Sub-pixels gathered in dedicated enclosure
- Minimized cross-talk to adjacent sub-pixels
- Superior color performance at any viewing angle

white glove services



installation

Vanguard LED can help with installation!

Vanguard LED Displays can support pre-installation planning through commissioning of the display.

Vanguard can provide the installation of cabinets and mounts at an additional cost.



training

Training and certification, at a personal level.

Bring your team to our offices or we can come to you at your facility. We will provide all tools needed to train on any specific product or on the technology in general.

Vanguard LED will provide Certificates of Achievement for all individuals who participate and are present for the duration of the training.



repair

Local pixel repair, by the skilled Vanguard LED team!

Vanguard LED has qualified in-house repair technicians. Technicians have received training direct from manufacturing engineers, ensuring both quality and timely repairs.

Track the status and progress of your repairs with our advanced RMA system. Feel secure in knowing that we support you and your Vanguard LED displays!



commissioning

Vanguard LED can help with installation!

Our Commissioning Services encompass the supervision of an installation and the training of on-site staff to handle the LED display.

everyday services



Convenient solution demos



Industry-leading warranty and repair support



Selecting the best product for each unique application



Clear and fast communication with a local resource



Designing the display the application needs



Pre-aging to correct minor issues to ensure a flawless installation



Detailed design drawings



Prompt troubleshooting and service support

Vanguard LED Displays

summation

A leader in innovative digital LED display solutions, Vanguard offers an unrivaled range of products, technologies, and support.

Vanguard is an American-owned company, headquartered in Lakeland, Florida. Our mission statement - Complete customer satisfaction, defined by our core values of expertise, integrity, responsiveness, service, and value.

Our core values take many practical forms including Industry leading new technology, expert design advice at the outset of a project, timely quotes, the quickest lead times in the industry, helpful CADs and electrical drawings, professional commissioning, proficient on-site training, and stellar after-sales services.

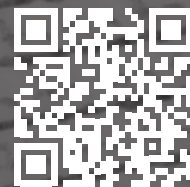

Scan to
contact us!

VANGUARD
LED DISPLAYS

