

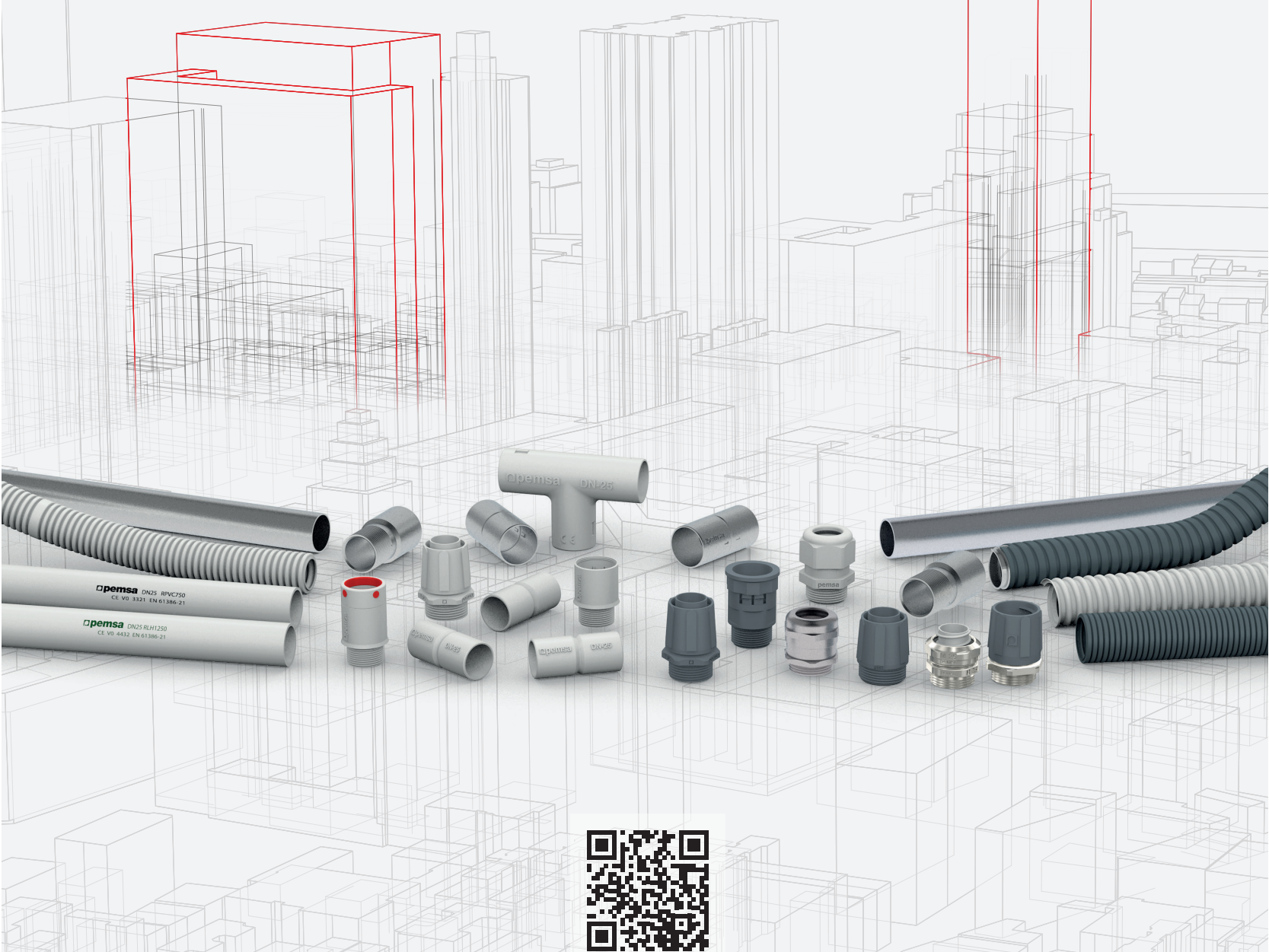

SISTEMAS DE TUBOS, RACORES Y PRENSAESTOPAS
CONDUITS, CONNECTORS AND CABLE GLAND SYSTEMS

GUÍA RÁPIDA
QUICK GUIDE

240



www.pemsa-rejiband.com



Materiales aislantes y Colores RAL / Insulating materials & RAL Colours

PC+ABS	Polycarbonato + ABS Libre de halógenos <i>Halogen Free Polycarbonate + ABS</i>	PA12	Poliamida 12 Libre de Halógenos <i>Polyamide 12 Halogen Free</i>	RAL 5012	Color Azul RAL 5012 <i>Blue Colour RAL 5012</i>
PVC	Policloruro de Vinilo <i>Polyvinyl Chloride</i>	PU	Poliuretano / <i>Polyurethane</i>	RAL 5024	Color Azul RAL 5024 <i>Blue Colour RAL 5024</i>
PP	Polipropileno Libre de Halógenos <i>Polypropylene Halogen Free</i>	PE	Polietileno / <i>Polyethylene</i>	RAL 7000	Color Gris RAL 7000 <i>Grey Colour RAL 7000</i>
PA6	Poliamida 6 Libre de Halógenos <i>Polyamide 6 Halogen Free</i>	NBR	Caucho NBR / <i>NBR rubber</i>	RAL 7011	Color Gris Oscuro RAL 7011 <i>Dark Grey Colour RAL 7011</i>
		PET	Poliestirester Termoplástico <i>Thermoplastic Polyester</i>	RAL 7031	Color Gris Oscuro RAL 7031 <i>Dark Grey Colour RAL 7031</i>
		TPV	Termoplástico <i>Thermoplastic</i>	RAL 7035	Color Gris Claro RAL 7035 <i>Light Grey Colour RAL 7035</i>
		PO	Poliéster / <i>Poliestirester</i>	RAL 9005	Color Negro RAL 9005 <i>Black Colour RAL 9005</i>

Sistemas de Protección a la Corrosión / Protective Corrosion Systems

Pemsa ofrece una amplia gama de Sistema de protección frente a la corrosión que incluyen diversos recubrimientos de cara a cubrir todos los requerimientos y ambientes

Pemsa offers a complete range of protective corrosion systems which includes some diferents coatings in order to cover all the requirements and enviroments.

	Sistema de Protección	Protection System
	Es un grupo de acabados con las mismas propiedades o características, prestaciones, estética, etc. que se comercializan en su conjunto.	<i>It is a group of finishes with the same properties or characteristics, features, aesthetics, etc. that are sold as a whole</i>
	Acabado	Finish
	Recubrimiento de protección frente a la corrosión.	<i>Corrosion protection coating.</i>

			Clase	
PG	PG3	Pregalvanizado / <i>Pregalvanised</i>	3	
EZ	EZ2	Electrocincado / <i>Electrogalvanised</i>	2	
	EZ3		3	
GC	HDG	Galvanizado en Caliente / <i>Hot Dip Galvanising</i>	4,5 / 5,5 7 / 8	
	ZL	Zinc Laminar / <i>Lamellar zinc</i>	8	
LN	LNI	Latón Niquelado / <i>Nickel-plated brass</i>	NA	



plastic 7035

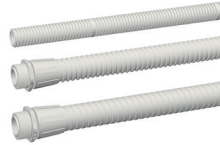

Tubos Rígidos y flexibles plásticos color RAL 7035
Rigid and flexible conduits RAL 7035 colour

09-12



metal



Tubos Rígidos metálicos
Rigid Metal Conduits

13-16



flexibl



Tubos flexibles para aplicaciones generales e industriales
Flexible conduits for general and industrial applications

17-22



pemsaflex

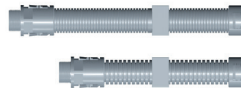

Tubos flexibles para aplicaciones industriales
Flexible conduits for industrial applications

23-30



cable glands



Prensaestopas plásticos y metálicos IP68 IP54
Plastic and metal Cable glands IP68 I54

31-40



Soluciones de Producto / *Product Solutions*
 Información Técnica / *Technical information*
 Contacto / *Contact*

41-48



**Sistema de Tubos Pemsa.
Guía de selección**

*Pemsa Conduits System.
Selection guide*



Denominación <i>Designation</i>	Manguito RLH <i>RLH Coupler</i>	Manguito RPVC <i>RPVC Coupler</i>	Racor caja RLH <i>Coupler Boxes RLH</i>	Manguito RL <i>RL Coupler</i>	Manguito RR <i>RR Coupler</i>

Denominación <i>Designation</i>	RLH	RPVC	CLH	RL / RLGC	RR / RRGC

	Características / <i>Features</i>						
	PC+ABS	PVC	PP	EZ	GC	EZ	GC
Ⓜ							
DN/NW min. / max.				DN16 / DN63			
🌡️ min. / max.	-15°C / +90°C	-5°C / +60°C	-15°C / +90°C	-45°C / +400°C			
📏 Flex	Rigido / <i>Rigid</i>			Media / <i>Medium</i>			
🛡️ HF	OK (IEC 60754-1)		OK (IEC 60754-1)		OK		OK
🚫	OK						
🛡️ IP	IP54						
IEC 61386	4432	4421	2332	5557		5557	

Homologaciones / <i>Approvals</i>						
IEC 61386	UK CA CE IEC 61386 RoHS III	UK CA CE IEC 61386 RoHS III	UK CA CE IEC 61386 RoHS III	UK CA CE IEC 61386 RoHS III	UK CA CE IEC 61386 RoHS III	UK CA CE IEC 61386 RoHS III

Aplicaciones / <i>Applications</i>					
🏢 Terciario Construcción <i>Tertiary Building</i>	●	●	●	●	●
🏭 Industria General <i>General Industry</i>	●	●		●	●
⚡ Fotovoltaica / Autoconsumo <i>Photovoltaic/ Renewables</i>	●	●			
📖	10	11	10	14	14



**Sistema de Tubos Pemsa.
Guía de selección**

*Pemsa Conduits System.
Selection guide*

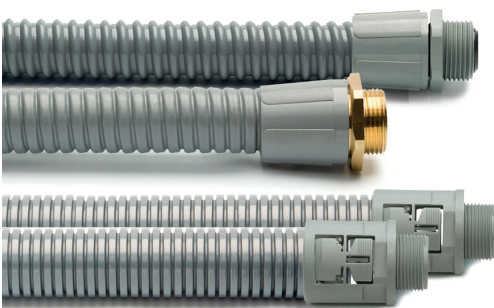

Racor P Coupler P	Racor RM RM Connector	Racor PA6 PA6 Connector	Racor REP REP Connector	Denominación Designation
TFA	ECOFLEX	LG-PA	ST-PA	Denominación Designation
		 7011 9005	 7011 9005	
Características / Features				
PVC	PG	Poliamida/Polyamide/PA6		Ⓜ
PVC	PVC			
07 / 48				DN/NW min. / max.
-5°C / +60°C		-40°C / +105°C		⚡ min. / max.
Alta / High				Flex
		OK		HF
OK				IP
IP65	IP65	IP54 / IP67 (REP + junta interior / internal joint)		IEC 61386
2421	3421	2443		
Homologaciones / Approvals				
UK CA CE IEC 61386 RoHS III	UK CA CE IEC 61386 RoHS III	UK CA CE IEC 61386 RoHS III	UK CA CE IEC 61386 RoHS III	IEC 61386
Aplicaciones / Applications				
				Terminario Construcción Tertiary Building
●	●	●	●	Industria General General Industry
		●	●	Fotovoltaica / Autoconsumo Photovoltaic / Renewables
19	20	26	25	ⓘ



Gama de Prensaestopas.

Guía de selección

Cable Glands Range.

Selection guide

Denominación <i>Ranges</i>	HEXADIN-P	IRIS-P / IRIS-P LONG	HSK-K
			
Características / Features			
	Poliamida / <i>Polyamide</i>		
Junta / Joint	TPV	TPV	NBR
M	M12-M40	M12-M63	M12-M63
PG	PG7-PG36	PG7-PG48	PG7-PG48
DN Ø	3,5 / 32	3,0 / 44,0	3,0 / 44,0
min. / max.	-20 °C / +100 °C	-20 °C / +100 °C	-40°C / +100 °C
	OK	OK	VO according to UL94
	OK	OK	OK
	OK	OK	OK
	RAL 7035	RAL 7035 RAL 7031 RAL 9005	RAL 7035 RAL 9005
	IP54	IP68 - 5 bar	IP68 (10 bares)
Homologaciones / Approvals			
Aplicaciones / Applications			
Terciario Construcción <i>Tertiary Building</i>	●	●	●
Industria General <i>General Industry</i>	●	●	●
Fotovoltaica / Autoconsumo <i>Photovoltaic/ Renewables</i>		●	●
	32	32	33



**Gama de Prensaestopas.
Guía de selección**

*Cable Glands Range.
Selection guide*

HEXADIN -M / HEXADIN -M LONG 	IRIS-M / IRIS-M LONG 	IRIS-M EMC 	HSK-M 	Denominación Ranges
Características / Features				
Latón Niquelado / <i>Nickel-Plated Brass</i>				
Neopreno	NBR	TPV	NBR	⊕ Junta / Joint
M12-M63	M12-M63	M12-M63	M12-M63	M 
PG7-PG36	PG7-PG36	PG07-PG48	PG7-PG48	PG 
4,0 / 46,0	3,0 / 48,0	3,5 / 44	3,0 / 44,0	DN Ø
-25°C / +60 °C	-40°C / +100 °C	-20 °C / +100 °C	-40°C / +100 °C	⊕ min. / max.
OK	OK	OK	V0 according to UL94	
OK	OK	OK	OK	
OK	OK	OK	OK	
Metal	Metal	Metal	Metal	
IP54	IP68 - 5 bar	IP68 - 5 bar	IP68 - 10 bar	
Homologaciones / Approvals				
				
Aplicaciones / Applications				
●	●		●	 Terciario Construcción <i>Tertiary Building</i>
●	●	●	●	 Industria General <i>General Industry</i>
	●	●	●	 Fotovoltaica / Autoconsumo <i>Photovoltaic/ Renewables</i>
34	34	35	35	



Plastic 7035

Tubos rígidos y flexibles plásticos color RAL 7035

Rigid and flexible conduits RAL 7035 colour

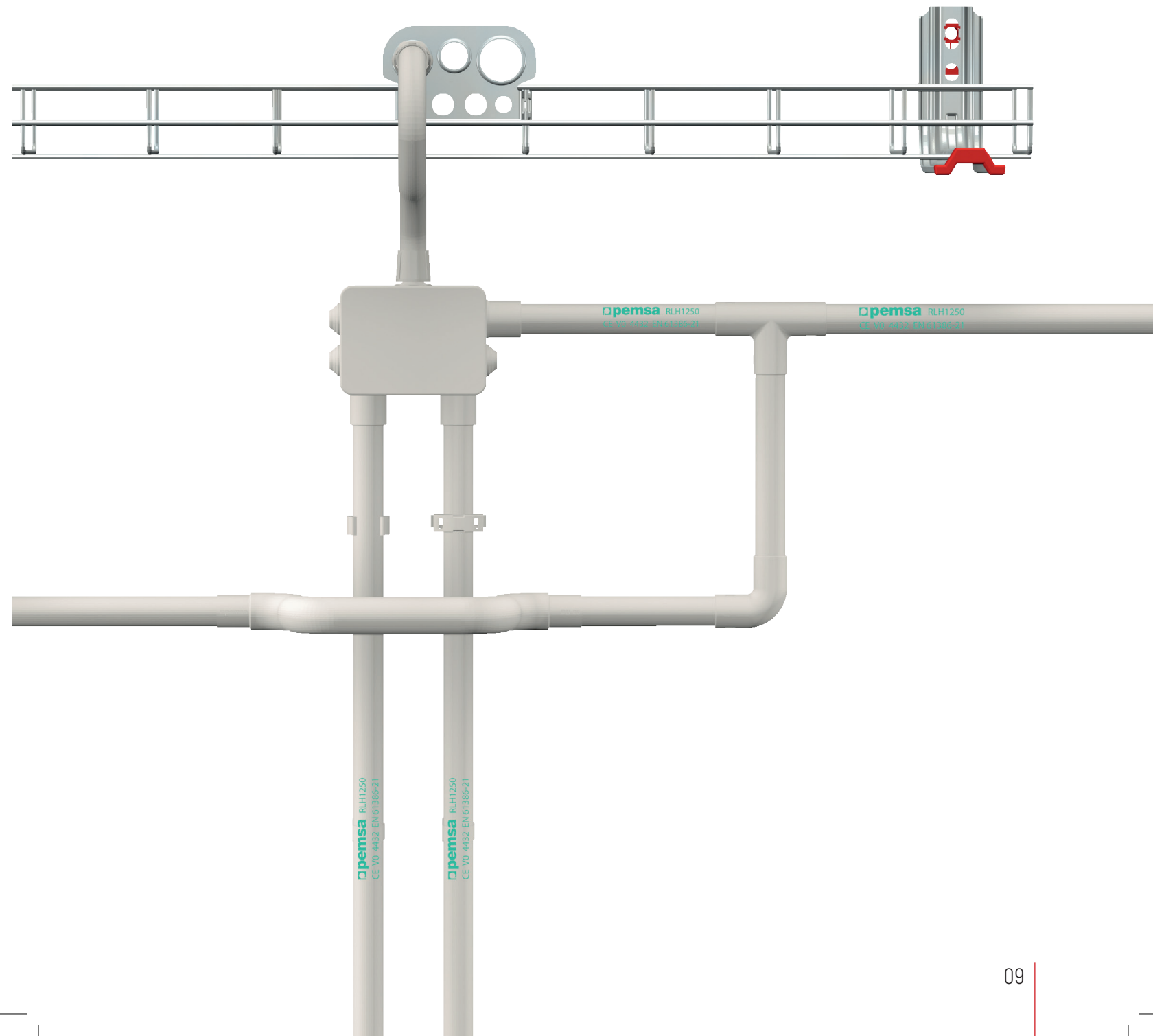



plastic 7035

pemsa

Tubo RLH1250 Libre de Halógenos
RLH1250 Halogen Free Conduit



DN	Ød1	Ød2	RAL 7035	kg/m	
DN16	12,8	16	13005116	0,091	57
DN20	16,6	20	13005120	0,124	57
DN25	21,6	25	13005125	0,166	57
DN32	28,0	32	13005132	0,240	30
DN40	35,2	40	13005140	0,358	30
DN50	45,2	50	13005150	0,470	15
DN63	58,0	63	13005163	0,598	15

PC+ABS	4432	4 (1250N)	4 (6J)	3(-15°)/2(+90°)
				44 OK

ETIM: EC001174

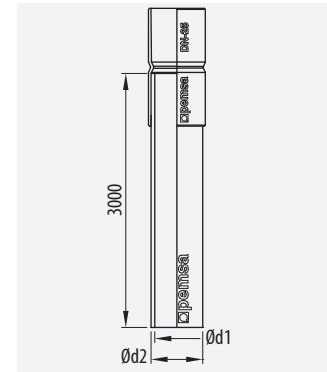

Manguito RLH
RLH Coupler



DN	L	RAL 7035	kg/u	
DN16	39	55008016	0,006	19
DN20	47	55008020	0,009	19
DN25	57	55008025	0,011	19
DN32	67	55008032	0,018	10
DN40	71	55008040	0,024	10
DN50	91	55008050	0,030	5
DN63	107	55008063	0,038	5

PC+ABS	-15/+90°	44	OK

ETIM: EC000937

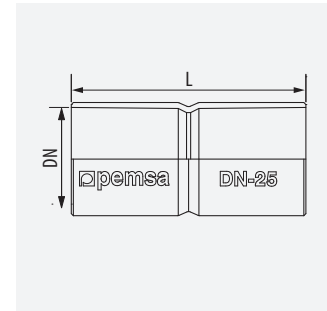

Racor Caja RLH
Coupler Boxes RLH



DN		RAL 7035	kg/u	
DN16	M16	55042016	0,003	100
DN20	M20	55042020	0,005	100
DN25	M25	55042025	0,007	100
DN32	M32	55042032	0,009	50
DN40	M40	55042040	0,012	50
DN50	M50	55042050	0,017	50
DN63	M63	55042063	0,024	50

PC+ABS	-15/+90°	44	OK

ETIM: EC000937

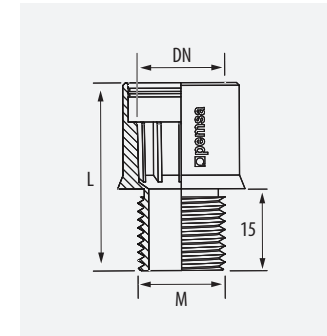

Curva 90° RLH
90° RLH Bend



DN	Ød2	L	RAL 7035	kg/u	
DN16	19	70	55016016	0,009	25
DN20	23	90	55016020	0,013	25
DN25	29	120	55016025	0,023	25
DN32	36	150	55016032	0,044	10

PC+ABS	-15/+90°	44	OK

ETIM: EC001493

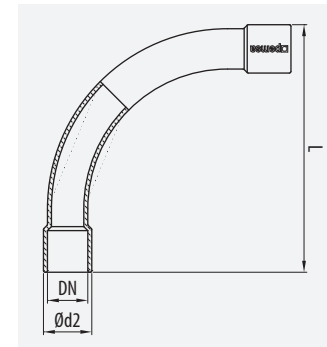



Curva flexible FRLH
Flexible Bend FRLH

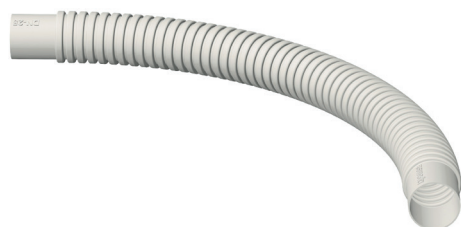

DN	Ød2	L	RAL 7035	kg/u	u
DN16	17	275	55090016	0,016	20
DN20	21,3	275	55090020	0,021	20
DN25	26,7	390	55090025	0,045	10
DN32	33,4	390	55090032	0,053	10

	M			IP	
	PP		-15/+90°	44	OK

ETIM: EC001493

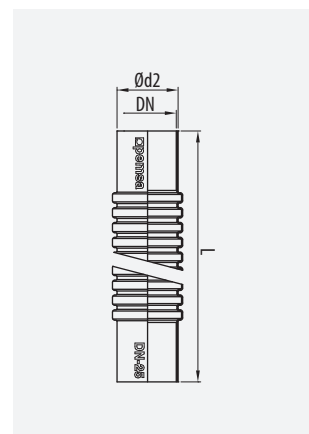

Tubo RPVC1250 4421
RPVC1250 Conduit 4421



DN	Ød1	Ød2	RAL 7035	kg/m	m
DN16	12,4	16	13050116	0,136	57
DN20	16,0	20	13050120	0,187	57
DN25	20,9	25	13050125	0,226	57
DN32	27,6	32	13050132	0,315	30
DN40	35,0	40	13050140	0,411	30
DN50	44,8	50	13050150	0,670	15
DN63	56,8	63	13050163	0,861	15

	M	IEC 61386		IP	
	PVC	4421	4 (1250N) 4 (6 J)	2 (-5) / 1 (+60)	44 OK

ETIM: EC001174

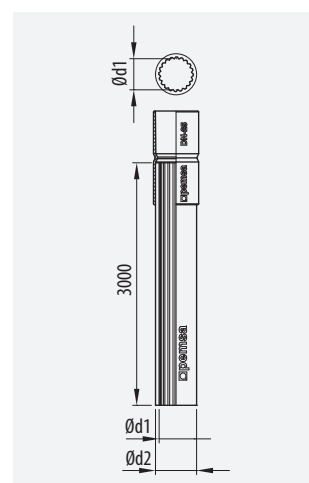

Manguito RPVC
RPVC Coupler



DN	L	RAL 7035	kg/u	u
DN16	39	55090016	0,006	19
DN20	47	55090020	0,009	19
DN25	57	55090025	0,011	19
DN32	67	55090032	0,018	10
DN40	71	55090040	0,024	10
DN50	91	55090050	0,030	5
DN63	107	55090063	0,038	5

	M			IP	
	PVC		-5/+60°	44	OK

ETIM: EC000937

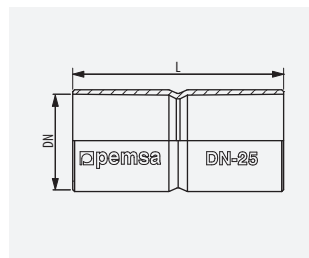

Racor Caja RPVC
Coupler Boxes RLH



DN	M	L	G	RAL 7035	kg/u	s
DN16	M16	34,5	15	55043016	0,004	19
DN20	M20	38,5	15	55043020	0,005	19
DN25	M25	43,5	15	55043025	0,007	19
DN32	M32	48,5	15	55043032	0,010	10
DN40	M40	50,5	15	55043040	0,013	10
DN50	M50	60,5	15	55043050	0,019	5
DN63	M63	68,5	15	55043063	0,027	5

	M			IP	
	PVC		-5/+60°	44	OK

ETIM: EC000937

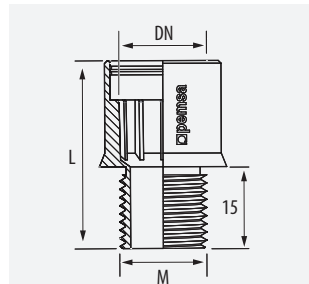



Curva 90° RPVC
90° RPVC Bend



DN	G	L	RAL 7035	kg/U	
DN16	19	70	55017016	0,009	25
DN20	23	90	55017020	0,013	25
DN25	29	120	55017025	0,023	25
DN32	36	150	55017032	0,044	10

PVC	-5/+60°	44	OK



ETIM: EC000937

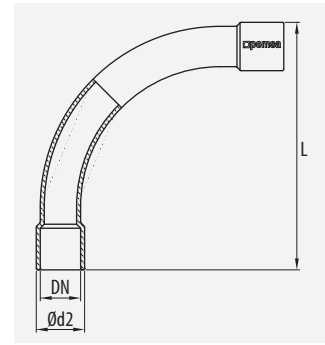

Curva flexible FRPVC
Flexible Bend FRPVC



DN	Ød2	L	RAL 7035	kg/U	
DN16	17	275	55091016	0,016	20
DN20	21,3	275	55091020	0,021	20
DN25	26,7	390	55091025	0,045	10
DN32	33,4	390	55091032	0,053	10

PVC	-5/+60°	44	OK

ETIM: EC001493

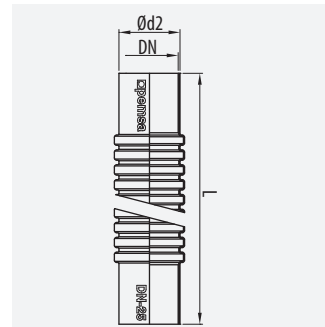

Tubo Pemsa CLH
CLH Conduit

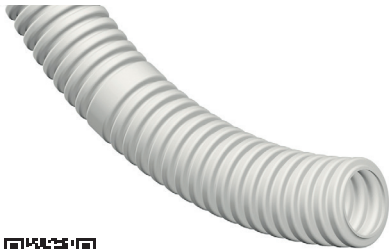

DN	Ød1	Ød2	mm	RAL 7035	kg/m	
DN16	11,2	16	125	10040216	0,035	100
DN20	14,4	20	125	10040220	0,046	100
DN25	18,4	25	140	10040225	0,062	75
DN32	24,8	32	140	10040232	0,092	50
DN40	31,6	40	100	10040240	0,115	25
DN50	40,4	50	70	10040250	0,158	25

PP	2332	2 (320N)	3 (2J)	3 (-15°)/ 2 (+90°)	65 OK

ETIM: EC001174

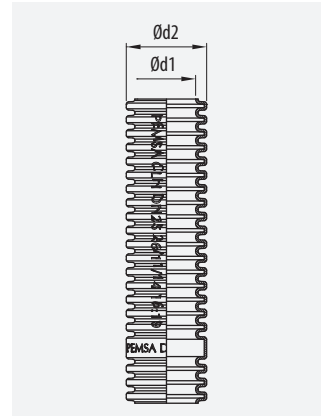

Clip Fijación
Fixing Clip

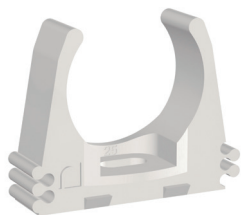

DN	L	RAL 7035	kg/u	
DN16	22	55023016	0,004	100
DN20	28	55023020	0,004	100
DN25	33	55023025	0,005	100
DN32	41	55023032	0,006	80
DN40	52	55023040	0,016	30
DN50	64	55023050	0,021	20

PA6	-15/+90°	OK

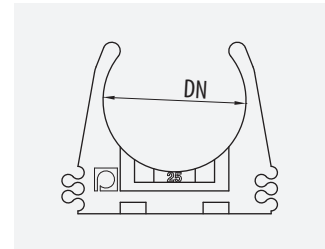

ETIM: EC002320

Clip Presión
Variable Clip

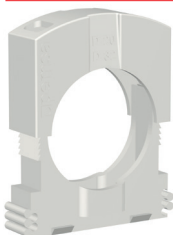

DN	RAL 7035	kg/u	
DN12/20	55024012	0,012	50
DN20/32	55024020	0,018	40
DN32/50	55024032	0,017	20

PA6	-15/+90°	OK

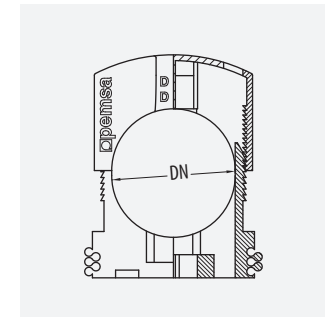



Metal

Tubos rígidos metálicos

Rigid metal conduits

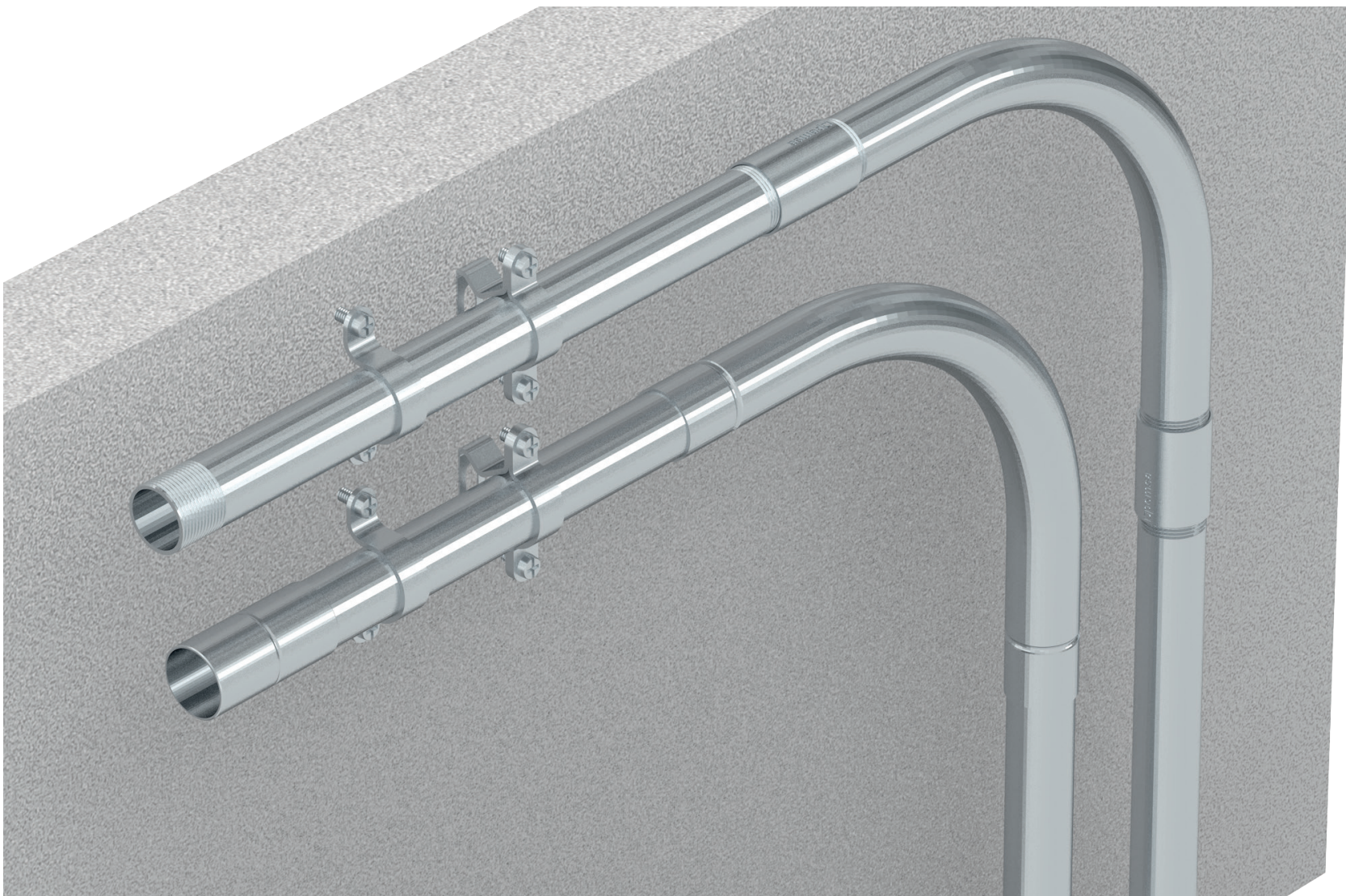



metal

pemsa

Tubo Rígido RL

RL Rigid

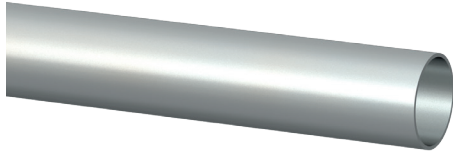

DN	Ød1	Ød2	EZ	kg/m	⊠
DN16	14,0	16	13040016	0,389	51
DN20	18,0	20	13040020	0,487	51
DN25	23,0	25	13040025	0,612	30
DN32	29,6	32	13040032	0,942	21
DN40	37,6	40	13040040	1,178	15
DN50	47,6	50	13040050	1,714	15
DN63	60,6	63	13040063	2,326	9

⊠	M	IEC 61386	⊠	⊠	⊠	⊠	⊠
AC	5557	5 (4000N)	5 (20J)	5 (-45°)/7 (+400°)	54	OK	

ETIM: EC001173

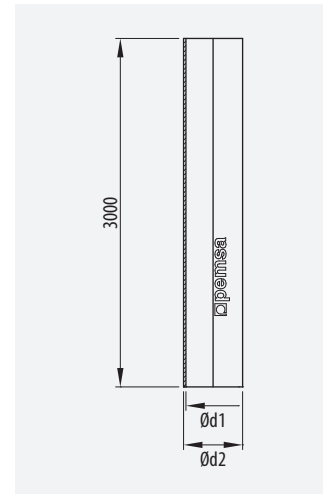

Tubo Rígido RR

RR Rigid Conduit



DN	⊠	Ød1	Ød2	G	EZ	kg/m	⊠
16	M16	13,6	16	15	13030016	0,462	51
20	M20	17,6	20	15	13030020	0,579	51
25	M25	22,6	25	20	13030025	0,73	30
32	M32	29,6	32	20	13030032	1,094	21
40	M40	37	40	20	13030040	1,374	15
50	M50	47	50	20	13030050	1,714	15
63	M63	60	63	20	13030063	2,629	9

⊠	M	IEC 61386	⊠	⊠	⊠	⊠	⊠
AC	5557	5 (4000N)	5 (20J)	5 (-45°)/7 (+400°)	54	OK	

ETIM: EC001173

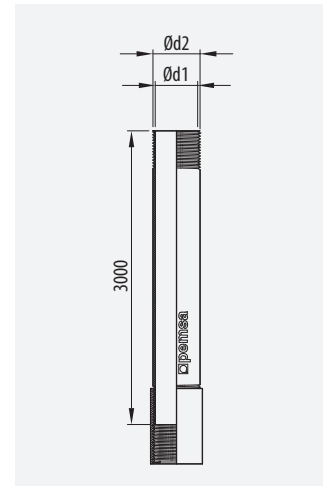

Manguito RL

RL Coupler



DN	Ød2	G	L	EZ	kg/u	⊠
DN16	18,1	21	45	55006016	0,022	100
DN20	22,1	24	50	55006020	0,030	50
DN25	27,1	26	55	55006025	0,040	25
DN32	34,1	31	65	55006032	0,091	20
DN40	42,5	34	70	55006040	0,121	12
DN50	52,5	45	90	55006050	0,190	6
DN63	65,5	51	105	55006063	0,275	3

⊠	M	⊠	⊠	⊠	⊠
AC		-45/+400°	54	OK	

ETIM: EC000937

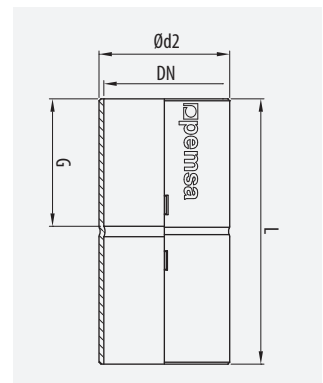

Manguito RR

RR Coupler



DN	⊠	Ød2	L	EZ	kg/u	⊠
16	M16	18,5	30	55004016	0,020	50
20	M20	22,5	35	55004020	0,030	50
25	M25	27,5	40	55004025	0,040	50
32	M32	34,5	43	55004032	0,060	25
40	M40	42,5	43	55004040	0,070	20
50	M50	52,5	52	55004050	0,120	10
63	M63	65,5	63	55004063	0,150	6

⊠	M	⊠	⊠	⊠	⊠
AC		-45/+400°	54	OK	

ETIM: EC000937

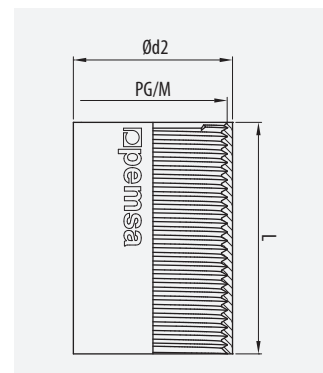



Curva 90° RL

90° RL Bend

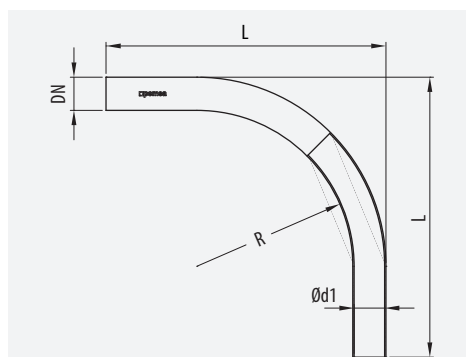

DN	Ød1	R	L	EZ	kg/u	📦
DN16	14,0	97	173	55015016	0,111	10
DN20	18,0	93	173	55015020	0,140	10
DN25	23,0	117	198	55015025	0,202	10
DN32	29,6	129	232	55015032	0,366	10
DN40	37,6	145	287	55015040	0,578	5
DN50	47,6	160	351	55015050	0,879	5
DN63	60,6	296	541	55015063	1,722	3

📄	Ⓜ	IEC 61386	🔧	🔧	🔧	🛡️	🚫
AC	5557	5 (4000N)	5 (20J)	5 (-45°/7 (+400°))	54	OK	

ETIM: EC000937



Curva 90° RR

90° RR Bend

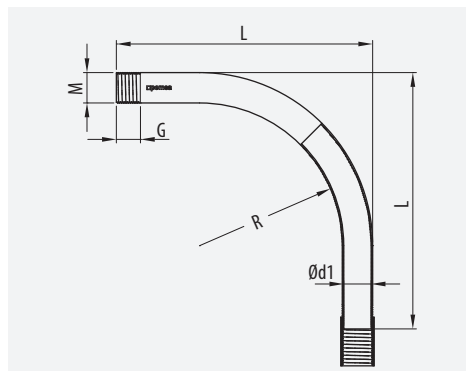

DN	Thread	Ød1	R	G	L	EZ	kg/u	📦
16	M16	13,6	97	15	173	55014016	0,152	10
20	M20	17,6	93	15	180	55014020	0,194	10
25	M25	22,6	117	20	198	55014025	0,28	10
32	M32	29,6	129	20	232	55014032	0,426	10
40	M40	37,0	145	20	287	55014040	0,787	5
50	M50	57,0	160	20	351	55014050	1,237	5
63	M63	60,0	296	20	541	55014063	2,273	3

📄	Ⓜ	IEC 61386	🔧	🔧	🔧	🛡️	🚫
AC	5557	5 (4000N)	5 (20J)	5 (-45°/7 (+400°))	54	OK	

ETIM: EC000937



Manguito Acoplamiento

Connection Coupler

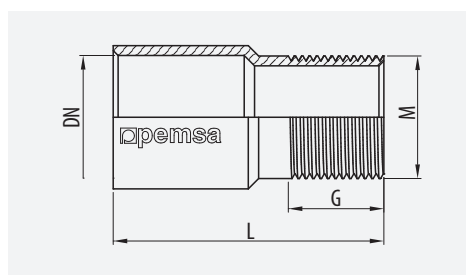

DN	Thread	G	L	EZ	kg/u	📦
DN16	M16	15	44	55007016	0,035	50
DN20	M20	15	48	55007020	0,048	50
DN25	M25	20	55	55007025	0,070	25
DN32	M32	20	63	55007032	0,104	25
DN40	M40	20	68	55007040	0,142	15
DN50	M50	20	83	55007050	0,216	6
DN63	M63	20	95	55007063	0,312	6

📄	Ⓜ	🔧	🛡️	🚫
AC		-45/+400°	44	OK

ETIM: EC000937



Racor RMT

RMT Coupler

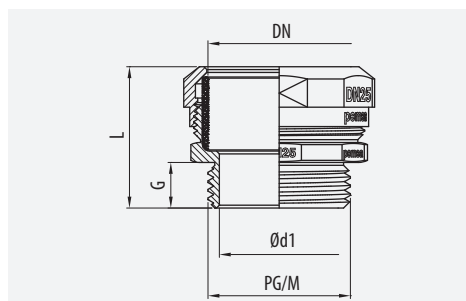

DN	Thread	Ød1	G	L	LN	kg/u	📦	
DN16	M16	12,0	6	18	24	37031160	0,018	100
DN20	M20	14,0	7	20	28	37031201	0,025	100
DN25	M25	21,0	8	20	32	37031250	0,034	50
DN32	M32	27,0	8	24	40	37031320	0,059	25
DN40	M40	35,0	9,5	29	48	37031400	0,094	20
DN50	M50	41,2	11	37	60	37031500	0,170	10
DN63	M63	63,0	15	47	76	37031630	0,301	5

📄	Ⓜ	🔧	🛡️	🚫
LN		-15/+90°	54	OK

ETIM: EC000937





metal

pemsa

Tubo Rígido RLGC Galvanizado en Caliente
RLGC Hot Dip Galvanised Conduit

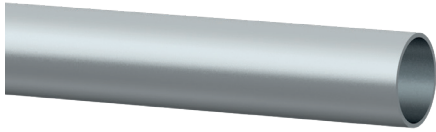

DN	Ød1	Ød2	GC	kg/m	m
DN16	14,0	16	13040116	0,428	30
DN20	18,0	20	13040120	0,536	30
DN25	22,6	25	13040125	0,674	30
DN32	29,6	32	13040132	1,036	21
DN40	37,6	40	13040140	1,296	15
DN50	47,6	50	13040150	1,885	15
DN63	60,6	63	13040163	2,559	15

M	IEC 61386	IP	RoHS III
AC	4457	4 (1250N)	4 (6J)
		5 (-45°)/7 (+400°)	54
			OK

ETIM: EC001173

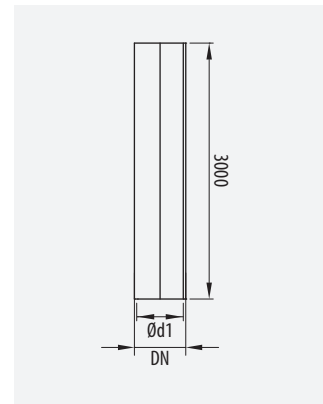

Tubo Rígido RRGC Galvanizado en Caliente
RRGC Hot Dip Galvanised Conduit

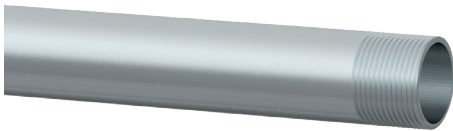

DN	Thread	Ød1	Ød2	G	GC	kg/m	m
16	M16	13,2	16	15	13030116	0,508	30
20	M20	16,8	20	15	13030120	0,637	30
25	M25	21,8	25	20	13030125	0,803	30
32	M32	28,8	32	20	13030132	1,203	21
40	M40	36,8	40	20	13030140	1,511	15
50	M50	46,8	50	20	13030150	1,885	15
63	M63	59,4	63	20	13030163	2,892	15

M	IEC 61386	IP	RoHS III
AC	5557	5 (4000N)	5 (20J)
		5 (-45°)/7 (+400°)	54
			OK

ETIM: EC001173

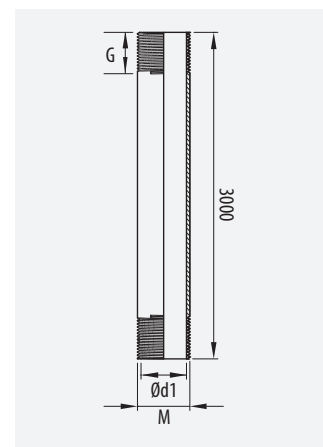

Manguito RLGC
RLGC Coupler



DN	Ød2	G	L	GC	kg/u	u
DN16	18,0	19	43	55006116	0,028	25
DN20	22,3	23	51	55006120	0,035	50
DN25	27,6	27	58	55006125	0,046	50
DN32	34,7	31	68	55006132	0,102	50
DN40	42,8	34	75	55006140	0,137	25
DN50	52,7	43	95	55006150	0,219	10
DN63	65,7	47	102	55006163	0,323	5

M	IP	RoHS III
AC	-45/+400°	54
		OK

ETIM: EC000937

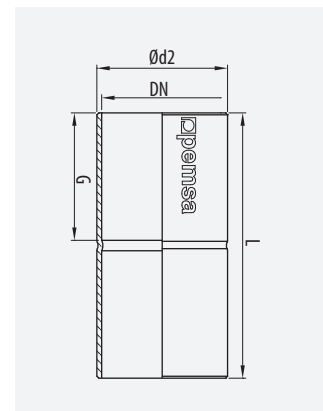

Manguito RRGC
RRGC Coupler



DN	Thread	Ød2	L	GC	kg/u	u
16	M16	18,5	27	55004116	0,026	25
20	M20	22,3	30	55004120	0,035	50
25	M25	27,6	37	55004125	0,046	50
32	M32	35,0	40	55004132	0,068	50
40	M40	44,1	50	55004140	0,081	25
50	M50	54,7	55	55004150	0,142	10
63	M63	65,7	55	55004163	0,185	5

M	IP	RoHS III
AC	-45/+400°	54
		OK

ETIM: EC000937

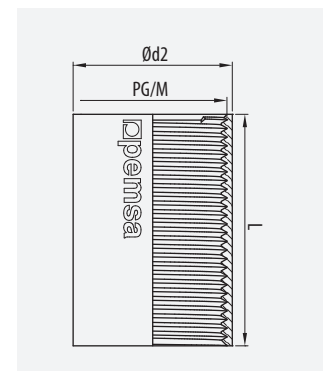



Flexibl

Tubos flexibles para aplicaciones generales e industriales

Flexible conduits for general and industrial applications

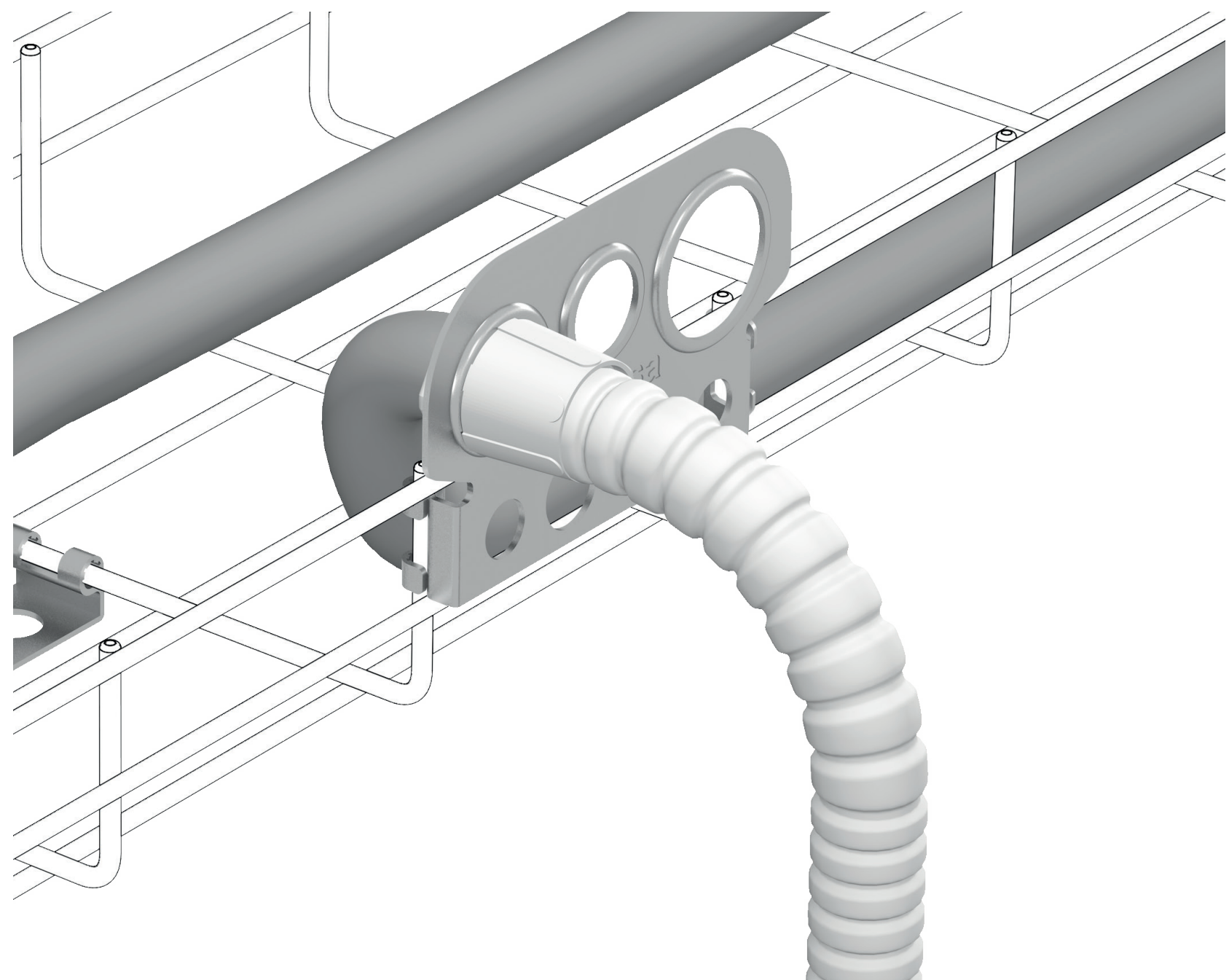



flexible

pemsa

Tubo Flexible TFA

TFA Flexible Conduit

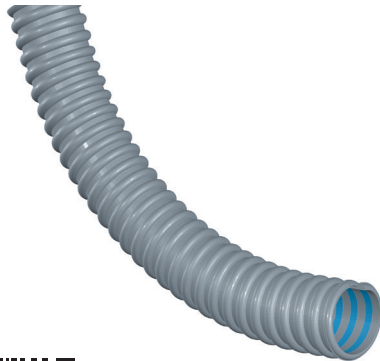

DN	Ød1	Ød2	$\frac{1}{r}$ mm	RAL 7011	kg/m	$\frac{1}{m}$
DN 7	10,0	13,3	14	10011007	0,055	25
DN 9	11,8	15,7	16	10011009	0,070	25
DN11	14,7	18,7	20	10011011	0,078	25
DN13	16,8	20,7	22	10011013	0,105	25
DN16	18,1	22,8	24	10011016	0,120	25
DN21	23,6	28,9	30	10011021	0,165	25
DN29	30,5	37,0	38	10011029	0,250	25
DN36	40,0	47,2	48	10011036	0,380	25
DN48	53,1	60,0	60	10011048	0,415	20

PG + PVC	2421	2 (320N)	4 (6J)	-5/+60°	65	OK	

ETIM: EC001177

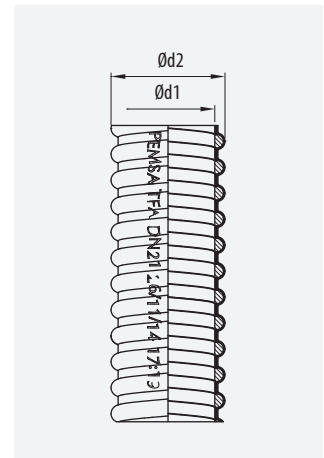

Tubo ECOFLEX

ECOFLEX flexible Conduit

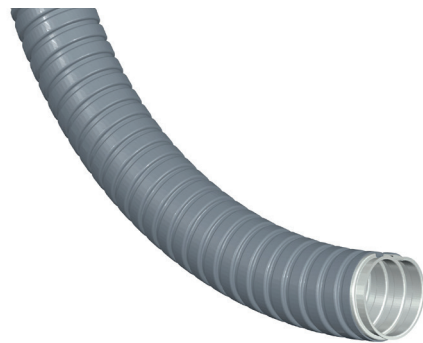

DN	Ød1	Ød2	$\frac{1}{r}$ mm	RAL 7031	kg/m	$\frac{1}{m}$
DN 7	9,7	12,7	24	11060107	0,096	50
DN 9	11,5	14,7	31	11060109	0,101	50
DN11	15,3	18,3	35	11060111	0,145	50
DN13	17,1	20,3	37	11060113	0,157	50
DN16	19,3	22,5	41	11060116	0,182	50
DN21	23,4	27,8	56	11060021	0,367	25
DN29	30,7	34,7	73	11060029	0,471	25
DN36	39,8	44,8	91	11060036	0,614	25
DN48	52,7	57,7	107	11060048	0,874	20

AC+PVC	3421	3 (750N)	4 (6J)	2 (-5°)/ 1 (+60°)	65	OK	

ETIM: EC001177

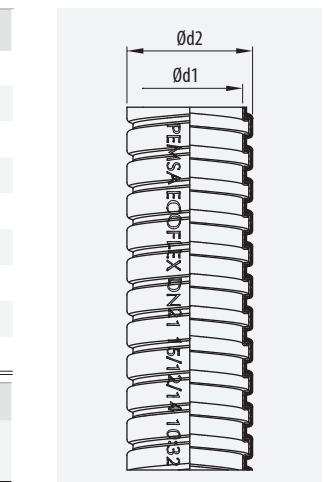

Tubo TM-PVC

TM-PVC flexible Conduit

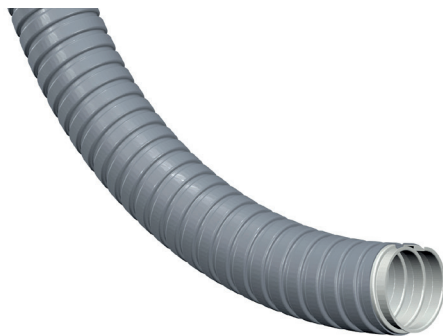

DN	Ød1	Ød2	$\frac{1}{r}$ mm	RAL 7031	kg/m	$\frac{1}{m}$
DN 7	9,7	12,7	31	11020107	0,102	50
DN 9	11,5	14,7	37	11020109	0,108	50
DN11	15,3	18,3	52	11020111	0,154	50
DN13	17,1	20,3	55	11020113	0,165	50
DN16	19,3	22,5	60	11020116	0,217	50
DN21	23,4	27,8	71	11020021	0,390	25
DN29	30,7	34,7	76	11020029	0,500	25
DN36	39,8	44,8	103	11020036	0,690	25
DN48	52,7	57,7	114	11020048	1,013	20

AC+PVC	4421	4 (1250N)	4 (6J)	2 (-5°)/ 1 (+60°)	65	OK	

ETIM: EC001177

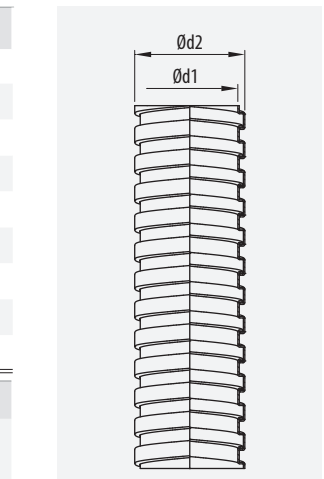



Racor P
P Connector

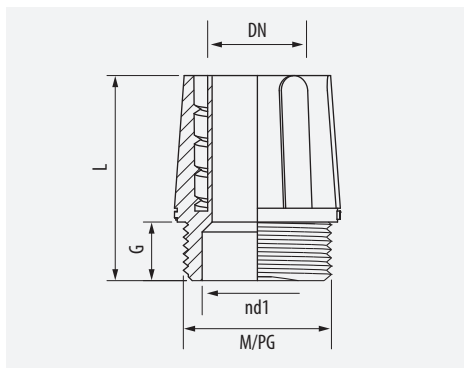

DN	Thread	Ød1	G	L	RAL 7001	kg/u	Box
DN 7	PG 7	8,1	9,1	27,2	30010007	0,002	100
DN 9	PG 9	10,6	9,1	28,2	30010009	0,003	100
DN11	PG11	14,1	9,7	31,9	30010011	0,005	50
DN13	PG13	15,7	10,2	33,4	30010013	0,006	50
DN16	PG16	17,2	10,6	34,2	30010016	0,007	25
DN21	PG21	21,8	12	40,0	30010021	0,011	25
DN29	PG29	26,0	13	47,5	30010029	0,021	10
DN36	PG36	37,0	13,5	51,5	30010036	0,030	8
DN48	PG48	59,3	16	59,3	30010048	0,052	5
DN 9	M16	11,0	9,1	28,2	30011160	0,003	100
DN11	M20	15,0	9,7	31,9	30011200	0,005	50
DN13	M20	15,0	10,2	33,4	30011201	0,006	50
DN16	M25	20,0	10,6	34,2	30011250	0,007	25
DN21	M32	26,0	12	40,0	30011320	0,010	25
DN29	M40	28,3	13	54,0	30011400	0,024	10
DN36	M50	36,6	13,5	59,0	30011500	0,033	8
DN48	M63	50,0	15	66,0	30011630	0,050	5

Material	PA6	Temperature	-25/+105°	IP	44	RoHS	OK
----------	-----	-------------	-----------	----	----	------	----

ETIM: EC001178



Racor RGp Giratorio
RGp Swivel Connector

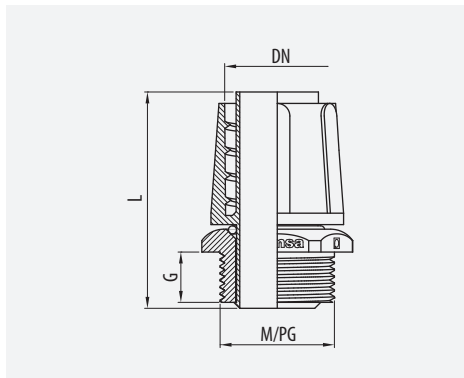

DN	Thread	G	L	Wrench	RAL 7001	kg/u	Box
DN 7	PG 7	8	36	18	35010007	0,005	100
DN 9	PG 9	10	39	21	35010009	0,007	100
DN11	PG11	10	42	25	35010011	0,010	50
DN13	PG13	10	44	27	35010013	0,011	50
DN16	PG16	11	47	30	35010016	0,016	25
DN21	PG21	11	52	36	35010021	0,022	25
DN29	PG29	12,5	66	44	35010029	0,043	10
DN36	PG36	12,5	67	54	35010036	0,058	8
DN48	PG48	15	76	69	35010048	0,090	5
DN 9	M16	10	39	21	35011160	0,006	100
DN11	M20	10	42	25	35011200	0,008	50
DN13	M20	10	44	25	35011201	0,009	50
DN16	M25	11	47	30	35011250	0,013	25
DN21	M32	11	52	36	35011320	0,018	25
DN29	M40	12,5	66	44	35011400	0,033	10
DN36	M50	12,5	67	54	35011500	0,044	8
DN48	M63	15	76	69	35011630	0,067	5

Material	PA6	Temperature	-25/+105°	IP	65	RoHS	OK
----------	-----	-------------	-----------	----	----	------	----

ETIM: EC001178





flexible

pemsa

Racor RGm Giratorio RGm Swivel Connector



PA6+LN	-25/+105°	65	OK

ETIM: ECO01178

DN		Ød1	G	L	Wrench	RAL 7000	kg/u	U
DN 7	PG 7	7,2	6,0	32,2		35020007	0,014	100
DN 9	PG 9	9,2	6,0	34,0		35020009	0,019	100
DN11	PG11	12,2	7,0	38,6		35020011	0,028	50
DN13	PG13	14,3	7,0	40,1		35020013	0,032	50
DN16	PG16	15,8	8,0	42,2		35020016	0,040	25
DN21	PG21	21,0	8,2	48,5		35020021	0,058	25
DN29	PG29	28,5	10,0	58,4		35020029	0,108	10
DN36	PG36	37,0	13,5	66,1		35020036	0,171	8
DN48	PG48	49,7	16,0	74,2		35020048	0,255	5
DN 7	M12	7,2	6,0	32,2		35021120	0,015	100
DN 9	M16	9,2	6,0	34,0		35021160	0,020	100
DN11	M20	12,2	7,0	38,6		35021200	0,027	50
DN13	M20	14,3	7,0	40,1		35021201	0,032	50
DN16	M25	15,8	8,0	42,2		35021250	0,042	25
DN21	M32	21,0	8,2	48,5		35021320	0,063	25
DN29	M40	28,5	10,0	58,4		35021400	0,109	10
DN36	M50	37,0	13,5	66,1		35021500	0,170	8
DN48	M63	49,7	16,0	74,2		35021630	0,253	5

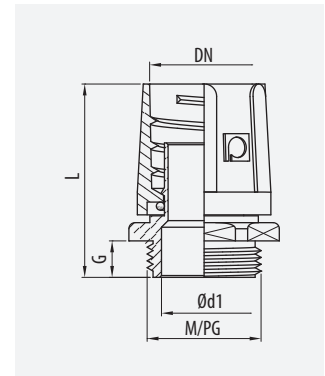

Racor RM RM Connector



LN	-25/+90°	54	OK

ETIM: ECO01178

DN		Ød1	G	L	Wrench	LN	kg/u	U
DN 7	PG 7	7,5	5	24	18	37020007	0,012	100
DN 9	PG 9	9,3	6	25	20	37020009	0,016	100
DN11	PG11	12,1	6,5	26,1	24	37020011	0,021	100
DN13	PG13	13,6	6	26,1	26	37020013	0,024	50
DN16	PG16	15,5	8,5	31,8	28	37020016	0,029	50
DN21	PG21	20,2	8	33,5	34	37020021	0,045	25
DN29	PG29	26,7	9,5	36,3	45	37020029	0,087	20
DN36	PG36	34,8	10	41	56	37020036	0,173	10
DN48	PG48	45,0	15	54,8	70	37020048	0,299	5
DN 7	M12	7,5	5	24	18	37021120	0,012	100
DN 9	M16	9,3	6	25	20	37021160	0,016	100
DN11	M20	12,1	6,5	26,1	24	37021200	0,021	100
DN13	M20	13,6	7	27,1	26	37021201	0,025	50
DN16	M25	15,5	8	31,8	28	37021250	0,029	50
DN21	M32	20,2	8	33,5	34	37021320	0,045	25
DN29	M40	26,7	8	36,3	45	37021400	0,084	20
DN36	M50	34,8	9	41	56	37021500	0,167	10
DN48	M63	45,0	14	54,8	70	37021630	0,289	5

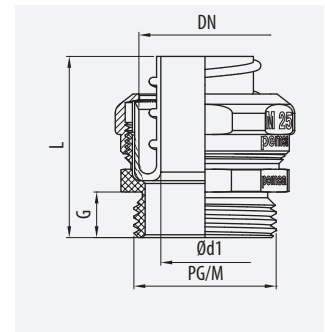

Racor Hembra RMH RMH Female Coupler



DN		G	Ød1	L	Wrench	LN	kg/u	U
DN 7	M12	6	7,5	24	18	37041120	0,015	100
DN 9	M16	7	9,3	27	20	37041160	0,02	100
DN11	M20	7,5	12,1	28,6	24	37041200	0,027	100
DN13	M20	8	13,6	29,1	26	37041201	0,032	50
DN16	M25	9	15,5	32,8	28	37041250	0,034	50
DN21	M32	9	20,2	35	34	37041320	0,056	25
DN29	M40	9	26,7	39,3	45	37041400	0,093	20
DN36	M50	10	34,8	40	56	37041500	0,188	10
DN48	M63	15	45	48,8	70	37041630	0,346	5

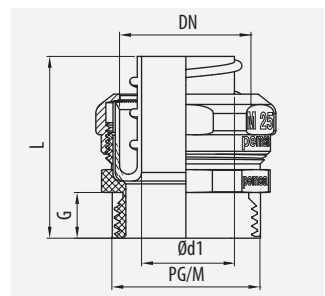

ETIM: ECO01178





Racor RMM

RMM Coupler



	LN	-45°/+150°	54	OK

DN		G	$\odot d_1$	L		LN	kg/u	
DN 7	PG 7	5	8	21,5	18	37025007	0,017	100
DN 9	PG 9	6	9,8	22	20	37025009	0,024	100
DN11	PG11	6,5	12,7	22,5	24	37025011	0,033	100
DN13	PG13	6	14,5	23	26	37025013	0,039	50
DN16	PG16	8,5	16,2	26	28	37025016	0,046	50
DN21	PG21	8	21	28	34	37025021	0,071	25
DN29	PG29	9,5	28,6	31	45	37025029	0,141	20
DN36	PG36	10	37,5	38	56	37025036	0,275	10
DN48	PG48	15	48,8	50	70	37025048	0,496	5
DN 7	M12	5	8	21,5	18	37026120	0,017	100
DN 9	M16	6	9,8	22	20	37026160	0,024	100
DN11	M20	6,5	12,7	22,5	24	37026200	0,033	100
DN13	M20	7	14,5	23	26	37026201	0,04	50
DN16	M25	8	16,2	26	28	37026250	0,046	50
DN21	M32	8	21	28	34	37026320	0,071	25
DN29	M40	8	28,6	31	45	37026400	0,138	20
DN36	M50	9	37,5	38	56	37026500	0,269	10
DN48	M63	14	48,8	50	70	37026630	0,486	5

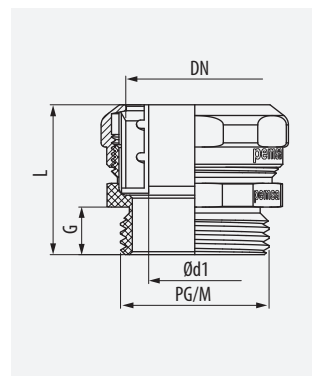

Casquillo RP

RP Plug



	PP	-25/+90°	54	OK

DN	$\odot d_1$	$\odot d_2$	L	RAL 7035	kg/u	
DN 7	7,5	14,8	16,0	37003107	0,001	100
DN 9	9,3	18,1	18,0	37003109	0,001	100
DN11	12,1	21,9	19,1	37003111	0,002	100
DN13	13,6	24,0	19,1	37003113	0,002	50
DN16	15,5	25,5	21,8	37003116	0,002	50
DN21	20,2	32,2	24,0	37003121	0,004	25
DN29	26,7	42,2	25,3	37003129	0,007	20
DN36	34,8	53,0	30,0	37003136	0,013	10
DN48	45,0	65,7	38,3	37003148	0,022	5

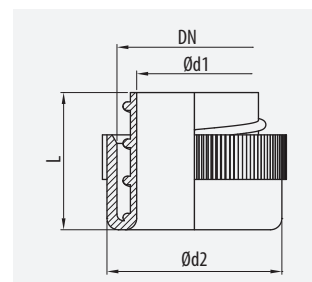

ETIM: EC000519

Tuerca TCP

TCP Nut

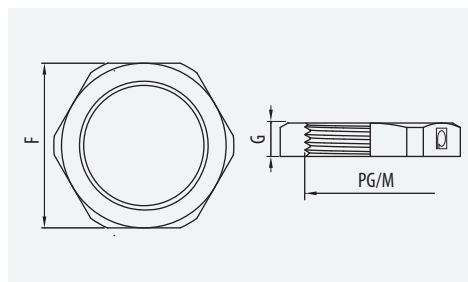
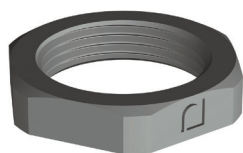

ETIM: EC000129



	G		RAL 7001	RAL 7035	RAL 9005	kg/u	
PG 7	5	19	40026007	40020007	40024007	0,001	100
PG 9	5	22	40026009	40020009	40024009	0,002	100
PG11	5	24	40026011	40020011	40024011	0,001	100
PG13	6	27	40026013	40020013	40024013	0,002	100
PG16	6	30	40026016	40020016	40024016	0,003	100
PG21	7	36	40026021	40020021	40024021	0,003	100
PG29	7	46	40026029	40020029	40024029	0,006	50
PG36	8	60	40026036	40020036	40024036	0,013	25
PG48	8	70	40026048	40020048	40024048	0,014	25
M12	5	18	40027120	40021120	40025120	0,001	100
M16	5	22	40027160	40021160	40025160	0,001	100
M20	6	26	40027200	40021200	40025200	0,002	100
M25	6	32	40027250	40021250	40025250	0,005	100
M32	7	41	40027320	40021320	40025320	0,005	50
M40	7	50	40027400	40021400	40025400	0,007	25
M50	8	60	40027500	40021500	40025500	0,010	25
M63	8	75	40027630	40021630	40025630	0,016	25

	PA6	-25/+100°	OK



flexible

pemsa

Tuerca TCM

TCM Nut

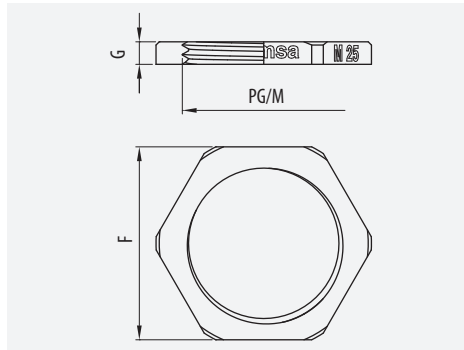

Ø	G	W	LN	kg/u	U
PG 7	2,8	15	40010007	0,002	100
PG 9	2,8	18	40010009	0,002	100
PG11	3,0	21	40010011	0,003	100
PG13	3,0	23	40010013	0,003	100
PG16	3,0	26	40010016	0,005	100
PG21	3,5	32	40010021	0,007	100
PG29	4,0	41	40010029	0,013	50
PG36	5,0	51	40010036	0,021	25
PG42	5,0	60	40010042	0,030	25
PG48	5,5	64	40010048	0,034	25

Ø	M	M	IP
LN	-45/+150°	OK	

ETIM: E000129



Ø	G	W	LN	kg/u	U
M12	2,8	15	40011120	0,002	100
M16	2,8	19	40011160	0,003	100
M20	3,0	24	40011200	0,004	100
M25	3,5	30	40011250	0,009	100
M32	4,0	36	40011320	0,011	50
M40	5,0	46	40011400	0,019	25
M50	5,0	60	40011500	0,026	25
M63	6,0	70	40011630	0,055	25



Junta Exterior

Flat Ring

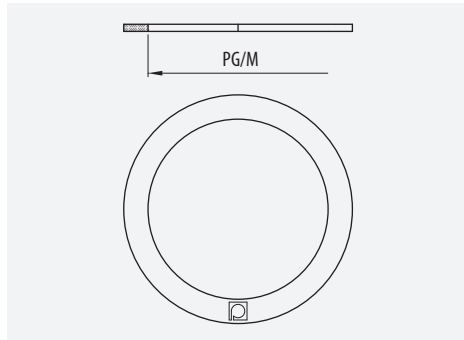

Ø	RAL 5024	kg/u	U
PG 7	39092007	0,001	100
PG 9	39092009	0,001	100
PG11	39092011	0,001	100
PG13	39092013	0,001	50
PG16	39092016	0,001	50
PG21	39092021	0,001	50
PG29	39092029	0,001	30
PG36	39092036	0,001	20
PG48	39092048	0,002	10

Ø	RAL 5024	kg/u	U
M12	39092112	0,000	50
M16	39092116	0,000	50
M20	39092120	0,001	50
M25	39092125	0,001	50
M32	39092132	0,001	30
M40	39092140	0,002	10
M50	39092150	0,003	10
M63	39092163	0,002	10

Ø	M	T	IP
NBR	-25/+105°	68	OK

ETIM: EC000098



Junta Tórica

O-RING

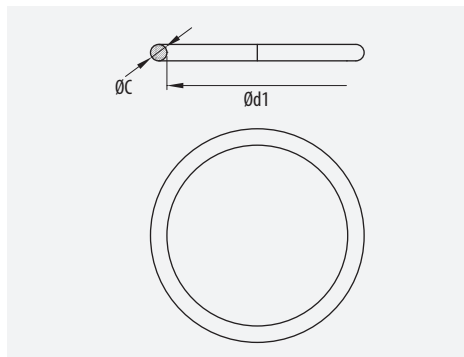

Ø	Ød2	C	RAL 9005	kg/u	U
PG 7	9,0	1,5	39096007	0,001	500
PG 9	12,0	1,5	39096009	0,001	500
PG11	16,0	1,5	39096011	0,001	500
PG13	17,2	1,8	39096013	0,001	100
PG16	22,0	2,0	39096016	0,002	500
PG21	29,0	2,0	39096021	0,003	500
PG29	33,0	2,0	39096029	0,004	250
PG36	43,0	2,0	39096036	0,006	100
PG48	55,0	2,0	39096048	0,007	50

Ø	Ød2	C	RAL 9005	kg/u	U
M12	9,0	1,5	39096112	0,001	500
M16	12,0	1,5	39096116	0,002	500
M20	17,2	1,8	39096120	0,002	500
M25	22,0	2,0	39096125	0,003	500
M32	29,0	2,0	39096132	0,004	250
M40	35,0	2,0	39096140	0,005	50
M50	43,0	2,0	39096150	0,066	50
M63	55,0	2,0	39096163	0,007	50

Ø	M	T	IP
NBR	4 (-25°) / 4 (+120°)	68	OK

ETIM: EC000098





Pemsaflex

Tubos flexibles para aplicaciones industriales

Flexible conduits for industrial applications

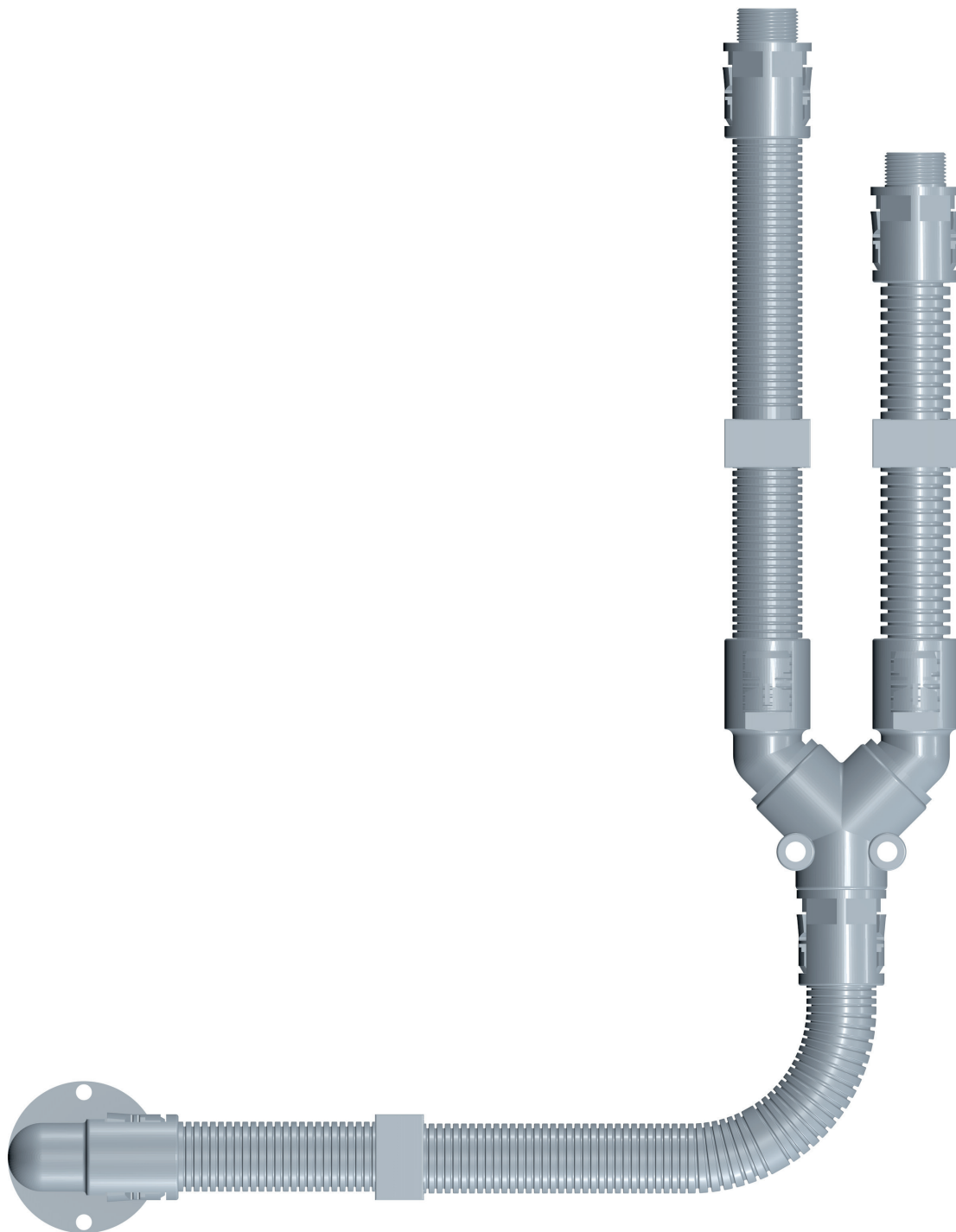



pemsaflex

pemsa

Tubo Flexible LG-PA

LG-PA Flexible Conduit

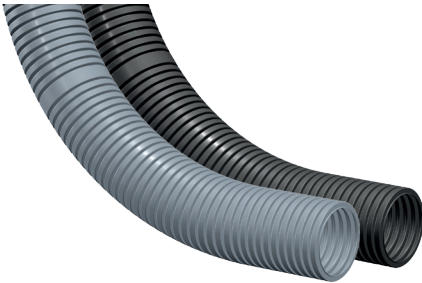

DN	Ød1	Ød2	R	RAL 7011	RAL 9005	kg/m	mm
DN 7	6,8	10,0	15	10042007	10043007	0,022	50
DN10	9,8	13,0	20	10042010	10043010	0,025	50
DN12	12,2	15,8	30	10042012	10043012	0,033	50
DN14	14,6	18,7	35	10042014	10043014	0,052	50
DN17	17,2	21,7	35	10042017	10043017	0,056	50
DN23	23,4	28,5	45	10042023	10043023	0,090	50
DN29	28,6	34,4	50	10042029	10043029	0,122	25
DN36	35,7	42,5	60	10042036	10043036	0,145	25
DN48	48,0	54,7	70	10042048	10043048	0,190	20

PA6	2423	2 (320N)	4 (6J)	-40°/+105°	67 OK

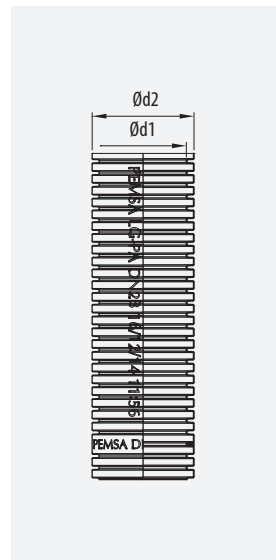

ETIM: EC001175



Tubo Flexible ST-PA

ST-PA Flexible Conduit

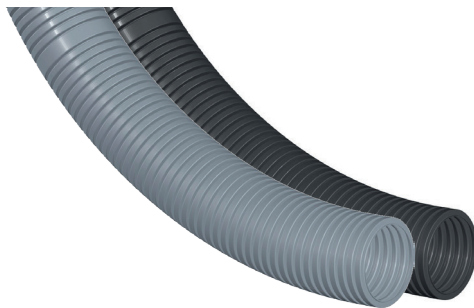

DN	Ød1	Ød2	R	RAL 7011	RAL 9005	kg/m	mm
DN 7	6,6	10	15	10040007	10041007	0,024	50
DN10	9,5	13	20	10040010	10041010	0,030	50
DN12	12,0	15,8	30	10040012	10041012	0,040	50
DN14	14,4	18,7	35	10040014	10041014	0,056	50
DN17	16,9	21,7	35	10040017	10041017	0,065	50
DN23	23,3	28,5	45	10040023	10041023	0,105	50
DN29	28,2	34,4	50	10040029	10041029	0,135	25
DN36	35,5	42,5	60	10040036	10041036	0,175	25
DN48	47,7	54,7	70	10040048	10041048	0,240	20

PA6	2423	2 (320N)	4 (6J)	-40°/+105°	67 OK

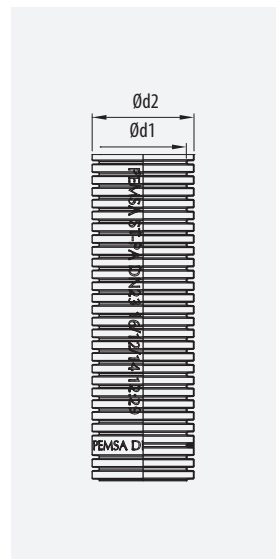

ETIM: EC001175



IDEA

Prensaestopas
Cable Gland

IRIS



68

UK CA CE



PA6

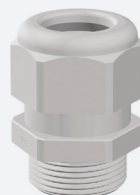

26



Racor REP
REP Connector

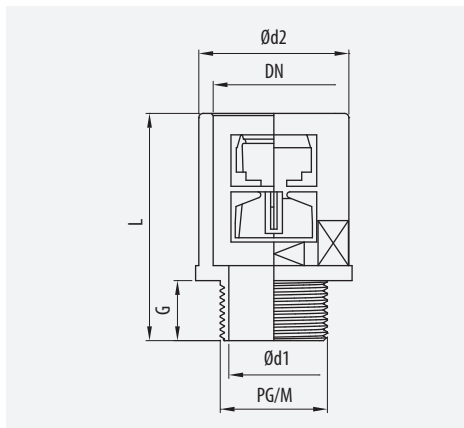

IP 67 con Junta interior

IP 67 with Internal joint

27



DN		$\varnothing d1$	$\varnothing d2$	G	L		RAL 7011	RAL 9005	kg/u	
DN 7	PG 7	7,0	17,5	8,2	34,5	15	31010007	32010007	0,003	50
DN 7	PG 9	7,0	18,5	9,7	36,0	15	31010009	32010009	0,004	50
DN 7	PG11	7,0	21,5	9,7	36,0	15	31010011	32010011	0,005	50
DN 7	PG13	7,0	24,0	9,7	36,0	15	31010013	32010013	0,005	50
DN10	PG 7	8,5	18,0	12,0	36,0	15	31010107	32010107	0,003	50
DN10	PG 9	10,8	20,0	12,0	36,0	15	31010109	32010109	0,003	50
DN10	PG11	11,0	23,5	12,0	36,0	15	31010111	32010111	0,004	50
DN10	PG13	11,0	25,5	12,0	36,0	15	31010113	32010113	0,005	50
DN12	PG 9	11,4	20,8	12,5	36,5	17	31010209	32010209	0,004	50
DN12	PG11	13,1	21,0	12,5	36,5	17	31010211	32010211	0,004	50
DN12	PG13	12,4	23,0	12,5	36,5	17	31010213	32010213	0,005	50
DN17	PG13	12,4	26,5	9,0	37,0	24	36010013	32010413	0,008	50
DN17	PG11	13,7	27,0	12,5	40,5	24	31010411	32010411	0,007	50
DN17	PG13	16,0	27,0	13,0	41,0	24	31010413	32010413	0,007	50
DN17	PG16	15,4	27,0	13,0	41,0	24	31010416	32010416	0,008	50
DN17	PG21	17,5	33,0	12,5	41,5	24	31010421	32010421	0,009	50
DN23	PG16	17,3	35,0	14,0	53,0	32	31010516	32010516	0,015	30
DN23	PG21	22,0	35,0	14,0	53,0	32	31010521	32010521	0,016	30
DN29	PG29	30,2	42,0	14,0	54,0	38	31010629	32010629	0,021	30
DN36	PG29	31,0	52,0	14,0	57,5	46	31010729	32010729	0,027	10
DN36	PG36	38,0	51,5	14,0	57,5	46	31010736	32010736	0,033	10
DN48	PG48	49,0	64,5	14,5	62,0	60	31010848	32010848	0,052	10
DN 7	M12	6,8	18,5	10,0	36,3	15	31012012	32012012	0,003	50
DN 7	M16	7,0	22,5	10,0	36,3	15	31012016	32012016	0,003	50
DN 7	M20	7,0	24,5	10,0	36,3	15	31012020	32012020	0,003	50
DN10	M12	8,0	18,5	9,5	33,5	15	31012112	32012112	0,004	50
DN10	M16	10,8	21,0	12,0	36,2	15	31012116	32012116	0,004	50
DN10	M20	10,9	26,5	12,0	36,5	15	31012120	32012120	0,004	50
DN12	M16	12,1	21,8	9,5	33,5	17	31012216	32012216	0,004	50
DN12	M20	12,8	27,0	12,5	36,5	17	31012220	32012220	0,005	50
DN17	M20	16,0	27,5	13,0	41,0	24	31012420	32012420	0,008	50
DN17	M25	17,9	29,0	12,0	40,0	24	31012425	32012425	0,007	50
DN17	M32	17,8	35,0	12,0	40,0	24	31012432	32012432	0,01	50
DN23	M25	21,0	36,5	14,0	53,0	32	31012525	32012525	0,016	30
DN23	M32	22,7	38,5	14,0	53,0	32	31012532	32012532	0,015	30
DN29	M32	26,9	42,0	14,0	54,0	38	31012632	32012632	0,021	30
DN29	M40	29,0	46,5	14,0	54,0	38	31012640	32012640	0,021	30
DN36	M40	34,3	52,5	14,0	57,5	46	31012740	32012740	0,029	10
DN36	M50	38,3	56,5	14,0	57,5	46	31012750	32012750	0,029	10
DN48	M50	44,2	65,5	14,0	62,0	60	31012850	32012850	0,047	10
DN48	M63	49,5	69,0	13,5	61,0	60	31012863	32012863	0,047	10

	PA6			
		-25/+105°	54	OK

ETIM: ECo01176



Racor PA6

PA6 Connector

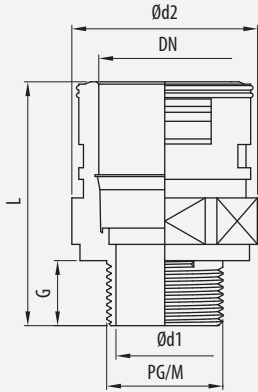
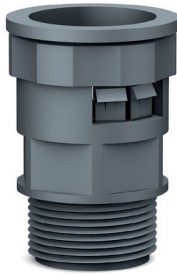

ETIM: EC001176



DN	Symbol	Ød1	Ød2	G	L	Wrench	RAL 7011	RAL 9005	kg/u	Box
DN 7	PG 7	6.9	18.7	11	37	15	31014007	32014007	0,005	100
DN10	PG 7	8	21.7	11	37	18	31014107	32014107	0,005	100
DN10	PG 9	10.3	21.7	11	37	18	31014109	32014109	0,006	100
DN10	PG11	10.6	21.7	11	37	18	31014111	32014111	0,006	100
DN10	PG13	10.6	21.7	11	37	18	31014113	32014113	0,007	100
DN12	PG 9	11.8	26	11	37.5	20	31014209	32014209	0,007	100
DN12	PG11	13.3	26	11	37.5	20	31014211	32014211	0,007	100
DN12	PG13	13	26	11	37.5	20	31014213	32014213	0,007	100
DN17	PG13	15.9	32	13	46	27	31014413	32014413	0,013	100
DN17	PG16	16.6	32	13	46	27	31014416	32014416	0,013	100
DN23	PG21	22.3	39.5	16	55	34	31014521	32014521	0,020	50
DN29	PG29	31.7	46.5	16	59	40	31014629	32014629	0,028	25
DN36	PG36	40.5	55.5	16	61.5	50	31014736	32014736	0,041	10
DN48	PG48	51.7	67.5	16	63.5	62	31014848	32014848	0,054	5
DN 7	M12	6.9	18.7	11	37	15	31015012	32015012	0,004	100
DN10	M12	8	21.7	11	37	18	31015112	32015112	0,006	100
DN10	M16	10.8	21.7	11	37	18	31015116	32015116	0,006	100
DN10	M20	10.5	21.7	11	37	18	31015120	32015120	0,006	100
DN12	M16	10.9	26	11	37.5	20	31015216	32015216	0,007	100
DN12	M20	13	26	11	37.5	20	31015220	32015220	0,008	100
DN17	M20	15.2	32	13	46	27	31015420	32015420	0,013	100
DN17	M25	18.6	32	13	46	27	31015425	32015425	0,014	50
DN23	M25	18.7	39.5	16	55	34	31015525	32015525	0,020	50
DN23	M32	26.8	39.5	16	55	34	31015532	32015532	0,017	25
DN29	M32	25.7	46.5	16	59	40	31015632	32015632	0,029	25
DN29	M40	32.6	46.5	16	59	40	31015640	32015640	0,030	10
DN36	M40	32.7	55.5	16	61.5	50	31015740	32015740	0,041	10
DN36	M50	40.2	55.5	16	61.5	50	31015750	32015750	0,042	5
DN48	M50	43.1	67.5	16	63.5	62	31015850	32015850	0,057	5
DN48	M63	51.4	67.5	16	63.5	62	31015863	32015863	0,058	5

PA6	-25/+105°	IP 67	OK
-----	-----------	-------	----

Racor PA6 90°

PA6 90° Connector

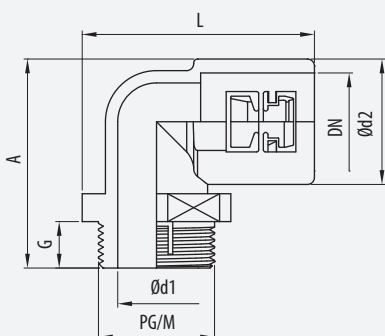
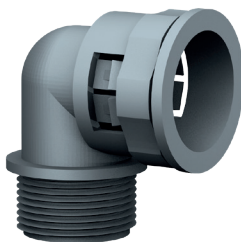

DN	Symbol	Ød1	Ød2	G	L	A	RAL 7011	RAL 9005	kg/u	Box
DN 7	PG 7	8.2	18.7	11	36.3	36.3	31043007	32043007	0,007	75
DN10	PG 9	10.3	21.7	11	37.3	43.8	31043109	32043109	0,009	50
DN12	PG11	13.3	26	11	41	43.8	31043211	32043211	0,014	50
DN14	PG13	15.3	28	11	44	46	31043313	32043313	0,019	50
DN17	PG16	16.6	32	13	51.5	51	31043416	32043416	0,022	40
DN23	PG21	22.4	39.5	16	61.2	64.3	31043521	32043521	0,035	25
DN 7	M12	8.2	18.7	11	36.3	35.7	31044012	32044012	0,008	75
DN10	M16	10.8	21.7	11	37.3	38.5	31044116	32044116	0,010	50
DN12	M16	10.9	26	11	41	43.8	31044216	32044216	0,014	50
DN14	M20	14.7	28	11	44	46	31044320	32044320	0,013	50
DN17	M20	15.2	32	13	51.5	51	31044420	32044420	0,015	40
DN23	M25	18.7	39.5	16	61.2	64.3	31044525	32044525	0,037	25

PA6	-25/+105°	IP 54	OK
-----	-----------	-------	----

ETIM: EC001176





Racor RREP
RREP Connector

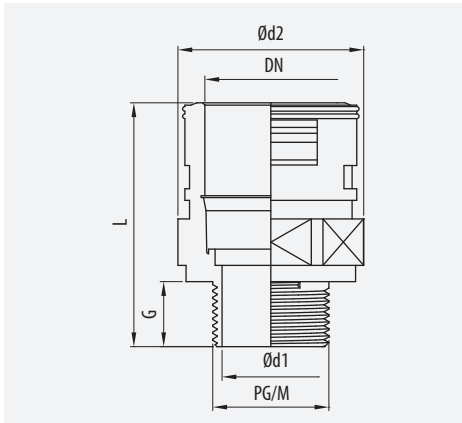

DN	PG	Ød1	Ød2	G	L	Wrench	RAL 7011	RAL 9005	kg/u	Box
DN10	PG 7	8,5	21,1	12,0	36,5	19	31100107	32100107	0,005	50
DN10	PG 9	11,0	21,1	12,0	36,5	19	31100109	32100109	0,005	50
DN10	PG11	10,0	21,1	12,0	36,5	19	31100111	32100111	0,006	50
DN10	PG13	11,0	23,5	12,0	37,0	19	31100113	32100113	0,006	50
DN12	PG 9	11,4	24,0	12,5	38,0	22	31100209	32100209	0,006	50
DN12	PG11	13,1	24,0	12,5	38,0	22	31100211	32100211	0,007	50
DN12	PG13	12,4	24,0	12,5	38,0	22	31100213	32100213	0,007	50
DN17	PG11	15,4	30,4	12,5	42,0	27	31100411	32100411	0,011	50
DN17	PG13	17,5	30,4	13,0	42,5	27	31100413	32100413	0,011	50
DN17	PG16	15,4	30,4	13,0	42,5	27	31100416	32100416	0,011	50
DN17	PG21	17,5	33,0	12,5	42,0	27	31100421	32100421	0,012	50
DN23	PG16	17,3	40,0	14,0	52,5	36	31100516	32100516	0,021	30
DN23	PG21	22,0	40,0	14,0	52,5	36	31100521	32100521	0,021	30
DN29	PG29	30,2	46,0	14,0	53,5	41	31100629	32100629	0,027	30
DN36	PG29	31,0	57,0	14,0	59,0	50	31100729	32100729	0,041	10
DN36	PG36	38,0	57,0	14,0	59,0	50	31100736	32100736	0,065	10
DN48	PG48	49,0	73,0	14,5	64,5	65	31100848	32100848	0,084	10
DN10	M12	8,0	21,1	9,5	34,0	19	31101112	32101112	0,006	50
DN10	M16	10,2	21,1	9,5	34,0	19	31101116	32101116	0,006	50
DN10	M20	10,9	26,5	12,0	37,0	19	31101120	32101120	0,006	50
DN12	M16	12,1	24,0	9,5	35,0	22	31101216	32101216	0,007	50
DN12	M20	12,8	24,0	12,5	38,0	22	31101220	32101220	0,007	50
DN17	M20	16,0	30,4	13,0	42,5	27	31101420	32101420	0,012	50
DN17	M25	17,9	30,4	12,0	41,5	27	31101425	32101425	0,011	50
DN23	M25	17,8	35,5	12,0	41,5	27	31101525	32101525	0,021	30
DN23	M32	22,7	40,0	14,0	52,5	36	31101532	32101532	0,02	30
DN29	M32	26,9	46,0	14,0	53,5	41	31101632	32101632	0,027	30
DN29	M40	29,0	46,5	14,0	53,5	41	31101640	32101640	0,027	30
DN36	M40	34,3	57,0	14,0	59,0	50	31101740	32101740	0,065	10
DN36	M50	38,3	57,0	14,0	59,0	50	31101750	32101750	0,065	10
DN48	M50	44,2	73,0	14,0	64,5	65	31101850	32101850	0,084	10
DN48	M63	49,5	73,0	13,5	63,5	65	31101863	32101863	0,084	10



	M				
	PAG		-25/+105°	67	OK

ETIM: ECO01176

IDEA

HSK-K Prensa-estopas Industriales

Industrial Cable Glands

ATEX II 2G 1D

UL CERTIFIED SAFETY IN E305904

33



Racor RA 90°

RA 90° Connector

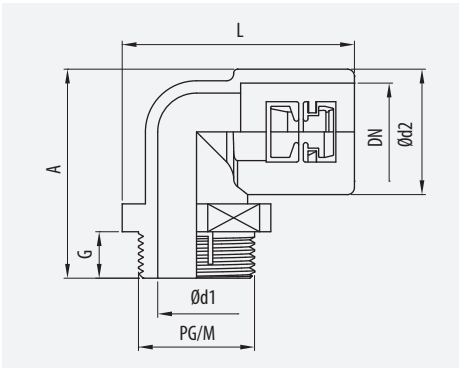
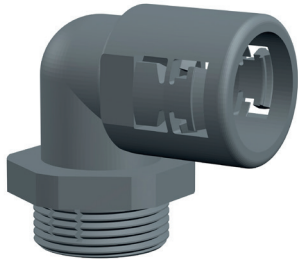

DN	PG	Ød1	Ød2	G	L	A	RAL 7011	RAL 9005	kg/u	☐
DN 7	PG 7	7,0	17,2	8,0	44,5	29,6	31040007	32040007	0,006	50
DN10	PG 7	8,4	18,0	10,5	38,3	33,5	31040107	32040107	0,007	50
DN10	PG 9	11,0	18,0	10,5	39,3	33,5	31040109	32040109	0,007	50
DN10	PG11	11,0	18,0	10,5	39,3	33,5	31040111	32040111	0,008	50
DN10	PG13	10,9	18,0	11,0	41,3	34,5	31040113	32040113	0,008	50
DN12	PG 9	11,7	20,8	11,0	42,0	36,5	31040209	32040209	0,009	50
DN12	PG11	13,0	20,8	11,0	43,0	36,5	31040211	32040211	0,009	50
DN12	PG13	15,0	20,8	11,0	43,3	36,5	31040213	32040213	0,008	50
DN17	PG13	16,0	27,0	13,0	47,5	45,0	31040413	32040413	0,013	50
DN17	PG16	17,2	27,0	13,0	47,5	45,0	31040416	32040416	0,013	50
DN23	PG21	22,1	35,0	14,0	65,0	54,0	31040521	32040521	0,023	30
DN29	PG29	30,3	41,8	14,0	73,8	60,9	31040629	32040629	0,036	30
DN36	PG36	38,0	51,0	14,0	86,3	70,0	31040736	32040736	0,062	10
DN48	PG48	49,7	63,8	14,0	102,5	82,3	31040848	32040848	0,095	10
DN 7	M12	6,9	17,2	10,0	44,5	42,8	31042012	32042012	0,009	50
DN 7	M16	7,0	17,2	10,0	46,5	42,8	31042016	32042016	0,009	50
DN 7	M20	7,0	17,2	10,0	47,5	42,8	31042020	32042020	0,009	50
DN10	M16	8,3	21,1	9,0	56,0	37,5	31042116	32042116	0,007	50
DN10	M20	10,0	21,1	9,0	58,0	37,5	31042120	32042120	0,008	50
DN12	M16	7,0	17,2	8,0	44,5	29,6	31042216	32042216	0,009	50
DN12	M20	12,0	23,9	9,0	59,0	41,2	31042220	32042220	0,009	50
DN17	M20	16,0	27,0	13,0	47,5	45,0	31042420	32042420	0,013	50
DN23	M25	20,3	35,0	14,0	65,5	54,0	31042525	32042525	0,026	30
DN29	M32	27,0	41,8	14,0	73,3	60,9	31042632	32042632	0,036	30
DN36	M40	33,5	51,0	14,0	86,3	70,0	31042740	32042740	0,061	10
DN48	M50	42,3	63,8	14,0	102,5	82,3	31042850	32042850	0,094	10

☐	M	PA6	°C	IP	OK
			-25/+105°	54	OK



ETIM: EC001176

Soporte Tubo

Conduit Clips

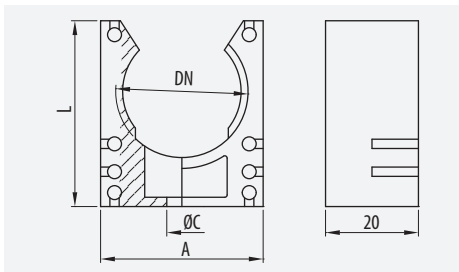

DN	L	A	RAL 7011	RAL 9005	kg/u	☐
DN 7	18	20	31095000	32095000	0,004	100
DN10	23	20	31095100	32095100	0,005	100
DN12	26	22	31095200	32095200	0,006	50
DN14	33	28	31095300		0,007	50
DN17	33	28	31095400	32095400	0,008	50
DN23	40	35	31095500	32095500	0,012	50
DN29	45	43	31095600	32095600	0,011	30
DN36	53	54	31095700	32095700	0,016	20
DN48	66	68	31095800	32095800	0,020	20

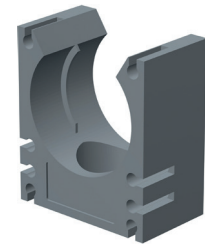

ETIM: EC002320

☐	M	PA6	°C	OK
			-25/+105°	OK

Tapa Soporte

Clip Lid

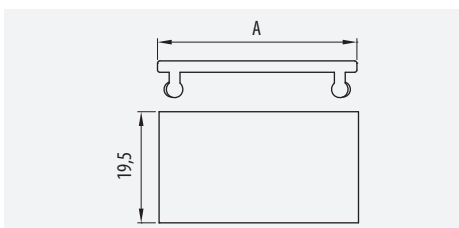

DN	A	RAL 7011	RAL 9005	kg/u	☐
DN7/10	20	31096000	32096000	0,001	100
DN12	22	31096200	32096200	0,001	50
DN14/17	28	31096400	32096400	0,001	50
DN23	35	31096500	32096500	0,001	50
DN29	43	31096600	32096600	0,002	30
DN36	54	31096700	32096700	0,002	20
DN48	68	31096800	32096800	0,003	20

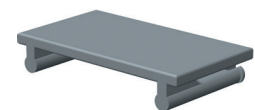

ETIM: EC000455

☐	M	PA6	°C	OK
			-25/+105°	OK



Soporte Tubo PA6

PA6 Conduit Clips

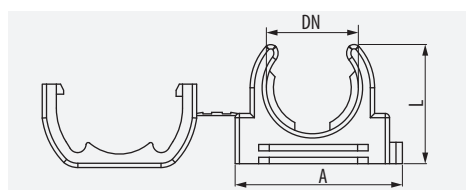

DN	L	A	RAL 7011	RAL 9005	kg/u	📦
DN 7	15	24.5	31094000	32094000	0,005	100
DN10	15	24.5	31094100	32094100	0,005	50
DN12	21	30	31094200	32094200	0,005	50
DN14	24	34	31094300	32094300	0,007	50
DN17	28	39	31094400	32094400	0,008	50
DN23	37	51	31094500	32094500	0,011	25
DN29	45.5	62	31094600	32094600	0,016	25
DN36	55.5	74.5	31094700	32094700	0,019	25
DN48	71	95.5	31094800	32094800	0,029	10



ETIM: EC002320

Junta Exterior

Flat Ring

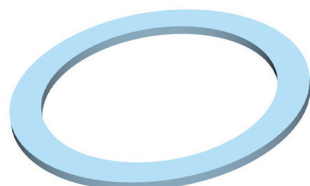

PG	RAL 5024	kg/u	📦
PG 7	39092007	0,001	100
PG 9	39092009	0,001	100
PG11	39092011	0,001	100
PG13	39092013	0,001	50
PG16	39092016	0,001	50
PG21	39092021	0,001	50
PG29	39092029	0,001	30
PG36	39092036	0,001	10
PG48	39092048	0,002	10
M12	39092112	0,000	50
M16	39092116	0,000	50
M20	39092120	0,001	50
M25	39092125	0,001	50
M32	39092132	0,001	30
M40	39092140	0,002	10
M50	39092150	0,003	10
M63	39092163	0,002	10

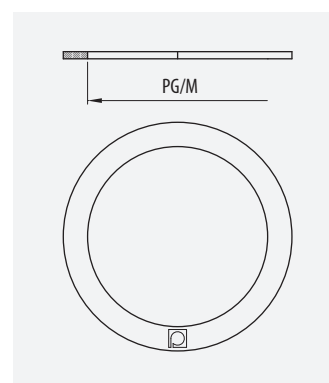

ETIM: EC000098

Junta Interior

Internal Joint



DN	RAL 9010	kg/u	📦
DN7	39091000	0,001	50
DN10	39091100	0,001	50
DN12	39091200	0,001	50
DN17	39091400	0,001	50
DN23	39091500	0,001	30
DN29	39091600	0,001	30
DN36	39091700	0,001	10
DN48	39091800	0,001	10

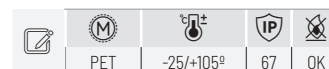
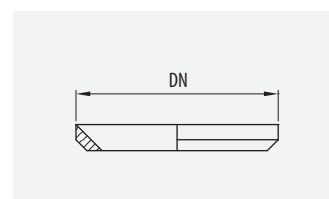

ETIM: EC000098

Abrazadera I

Clamp I



DN	A	B	C	EZ	kg/u	📦
DN 7	25	12,5	4,2	39095000	0,035	100
DN10	27	12,5	4,2	39095100	0,040	100
DN12	30	12,5	4,2	39095200	0,042	100
DN17	40	15,5	5,5	39095400	0,093	100
DN23	48	15,5	5,5	39095500	0,114	50
DN29	60	18	6,2	39095600	0,233	30
DN36	74	18	6,3	39095700	0,283	20
DN48	86	18,5	6,2	39095800	0,342	20

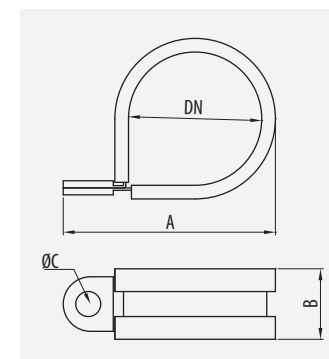

ETIM: EC000464





Prensaestopas

Prensaestopas plásticos y metálicos

Plastic and metal cable glands

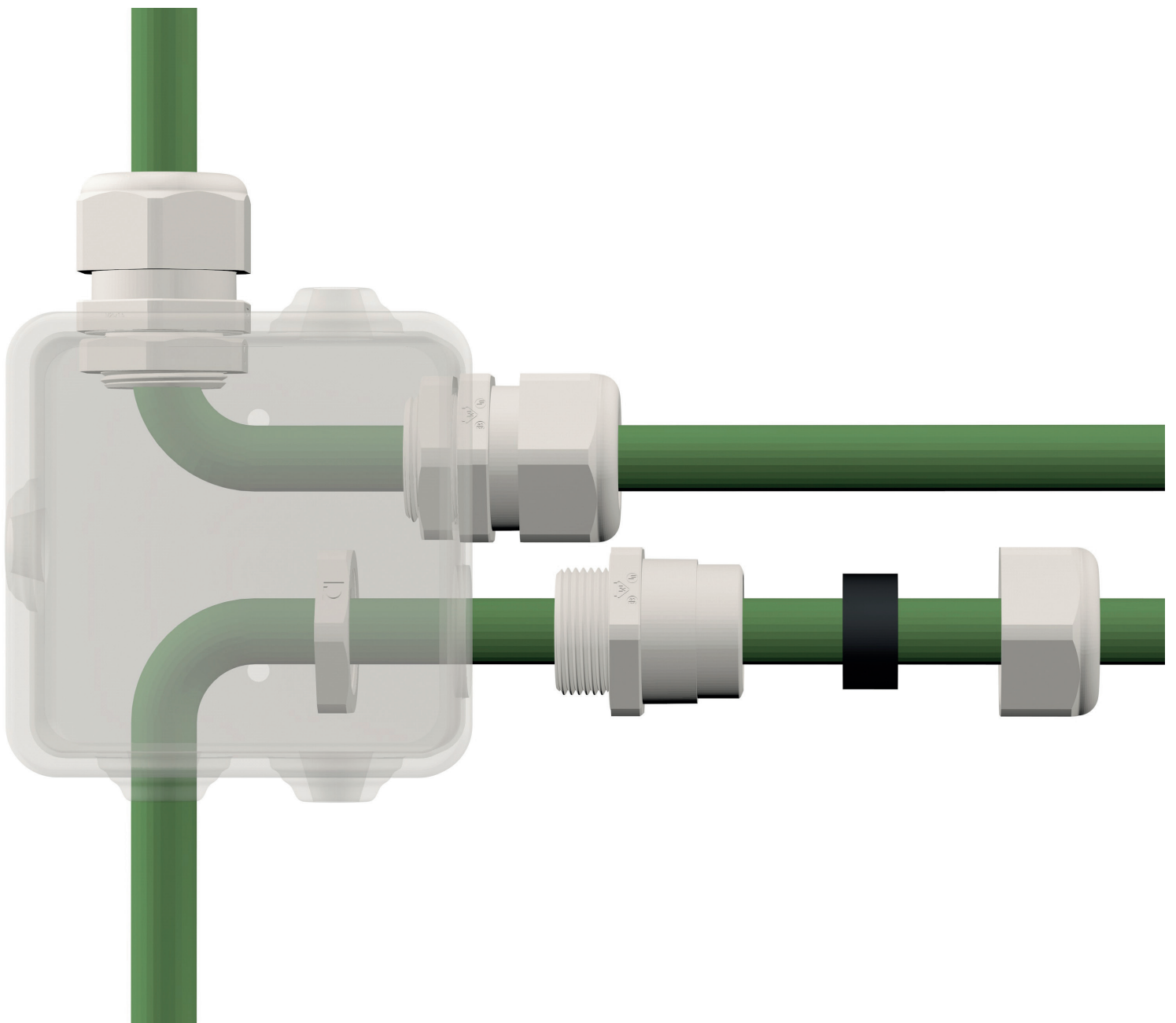



Prensaestopas HEXADIN-P
HEXADIN-P Cable Gland



DN		G	L		RAL 7035	kg/u	
3,5/6	PG 7	8	29	15	20010007	0,004	50
4,5/7	PG 9	8	30	19	20010009	0,006	50
6/9	PG11	8	30	22	20010011	0,008	50
9/12	PG13	9	35	24	20010013	0,009	50
11/14	PG16	10	38	27	20010016	0,011	50
14/18	PG21	11	43	33	20010021	0,019	50
18/25	PG29	11	46	42	20010029	0,034	25
25/32	PG36	13	62	53	20010036	0,061	10
3,5/6	M12	8	29	15	20011120	0,004	50
4,5/7	M16	8	30	19	20011160	0,006	50
6/9	M16	8	30	22	20011161	0,008	50
9/12	M20	9	35	24	20011200	0,009	50
11/14	M20	10	38	27	20011201	0,011	50
14/18	M25	11	43	33	20011250	0,019	50

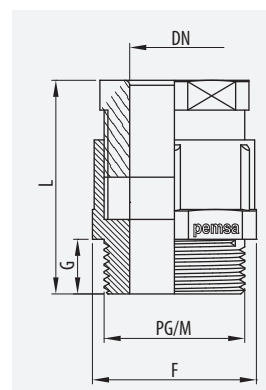

PA6+NBR		-25°/+60°	54	OK



ETIM:EC000441

Prensaestopas IRIS-P
IRIS-P Cable Gland



DN		G	L		RAL 7035	RAL 7001	RAL 9005	kg/u	
3/6,5	PG 7	8	32	15	21040007	21060007	21050007	0,003	50
4/8	PG 9	8	36	19	21040009	21060009	21050009	0,005	50
5/10	PG11	8	37	22	21040011	21060011	21050011	0,008	50
6/12	PG13	9	38	24	21040013	21060013	21050013	0,010	50
10/14	PG16	9	42	27	21040016	21060016	21050016	0,013	50
13/18	PG21	11	49	33	21040021	21060021	21050021	0,021	50
18/25	PG29	11	52	42	21040029	21060029	21050029	0,036	25
22/32	PG36	13	64	53	21040036	21060036	21050036	0,064	10
30/38	PG42	13	66	60	21040042	21060042	21050042	0,078	5
34/44	PG48	14	69	65	21040048	21060048	21050048	0,089	5
3/6,5	M12	8	32	15	21041120	21061120	21051120	0,003	50
4/8	M16	8	36	19	21041160	21061160	21051160	0,006	50
5/10	M16	10	39	22	21041161	21061161	21051161	0,006	50
6/12	M20	10	39	24	21041200	21061200	21051200	0,010	50
10/14	M20	10	43	27	21041201	21061201	21051201	0,010	50
13/18	M25	10	48	33	21041250	21061250	21051250	0,021	50
18/25	M32	10	51	42	21041320	21061320	21051320	0,039	25
22/32	M40	10	61	53	21041400	21061400	21051400	0,078	10
32/38	M50	18	71	60	21041500	21061500	21051500	0,100	5
37/44	M63	18	73	70	21041630	21061630	21051630	0,140	5

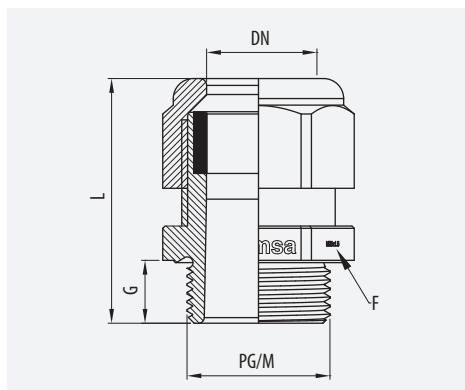

PA 6+TPV		-20°/+100°	68	OK



ETIM:EC000441



Prensaestopas IRIS-P Long
IRIS-P Long Cable Gland



DN		G	L	⚙	RAL 7035	kg/u	📦
3/6,5	PG7	24	15	15	21044007	0,004	100
4/8	PG9	28	15	19	21044009	0,007	100
5/10	PG11	29	15	22	21044011	0,008	100
6/12	PG13	29	15	24	21044013	0,010	100
10/14	PG16	33	15	27	21044016	0,013	100
13/18	PG21	38	15	33	21044021	0,022	50
3/6,5	M12	24	15	15	21045120	0,005	100
4/8	M16	28	15	19	21045160	0,011	100
5/10	M16	29	15	22	21045161	0,009	100
6/12	M20	29	15	24	21045200	0,011	100
10/14	M20	33	15	27	21045201	0,014	100
13/18	M25	38	15	33	21045250	0,022	50
18/25	M32	41	18	42	21045320	0,038	25
22/32	M40	51	18	53	21045400	0,070	10

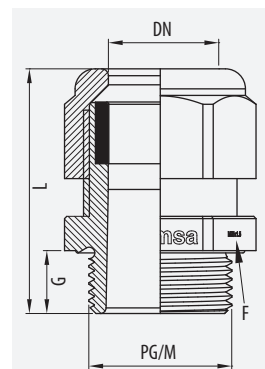

📄	Ⓜ	🔥	🛡	🚫
PA 6+TPV		-20°/+100°	68	OK

ETIM:EC000441

Prensaestopas HSK-K
HSK-K Cable Gland



DN		G	L	⚙	RAL 7035	RAL 9005	kg/u	📦
3/ 6,5	PG 7	8	29	15	22010007	22012007	0,005	50
4/ 8	PG 9	8	30	19	22010009	22012009	0,006	50
5/10	PG11	8	33	22	22010011	22012011	0,008	50
6/12	PG13	9	36	24	22010013	22012013	0,009	50
10/14	PG16	10	38	27	22010016	22012016	0,013	50
13/18	PG21	11	42	33	22010021	22012021	0,022	50
18/25	PG29	11	49	42	22010029	22012029	0,040	25
22/32	PG36	13	61	53	22010036	22012036	0,058	10
37/44	PG48	14	63	65	22010048	22012048	0,099	5
3/ 6,5	M12	8	29	15	22011120	22013120	0,005	50
4/ 8	M16	8	30	19	22011160	22013160	0,006	50
5/10	M16	8	33	22	22011161	22013161	0,007	50
6/12	M20	9	36	24	22011200	22013200	0,009	50
10/14	M20	9	37	27	22011201	22013201	0,013	50
13/18	M25	11	42	33	22011250	22013250	0,022	50
18/25	M32	11	50	42	22011320	22013320	0,040	25
22/32	M40	13	61	53	22011400	22013400	0,070	10
32/38	M50	13	62	60	22011500	22013500	0,090	5
37/44	M63	14	63	65	22011630	22013630	0,099	5

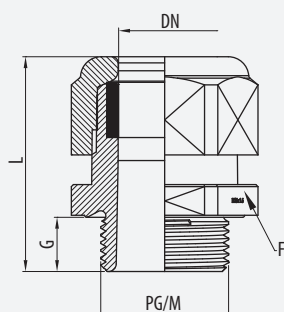

📄	Ⓜ	🔥	🛡	🚫
PA 6+NBR		-40°/+100°	68	OK

ETIM: EC000441





Prensaestopas Hexadin-M

Hexadin-M Cable Gland



LN+NBR	-25°/+60°	54	OK	

ETIM:EC000441

DN		G		LN	kg/u	
6 / 8	PG 7	5,0	14	20050007	0,009	50
4/10	PG 9	6,0	18	20050009	0,013	50
6,5/12	PG11	6,0	20	20050011	0,018	50
6,5/13,5	PG13	6,5	22	20050013	0,024	50
6,5/16	PG16	6,5	24	20050016	0,029	50
9/20	PG21	7,0	30	20050021	0,045	25
17/28	PG29	8,0	40	20050029	0,085	25
23/34	PG36	9,0	50	20050036	0,137	10
35/46	PG48	10,0	64	20050048	0,278	5
5/ 7	M12	7,0	14	20051120	0,013	50
4/ 9,5	M16	7,0	18	20051160	0,018	50
6/13	M20	7,0	22	20051200	0,024	50
6/15	M25	8,0	27	20051250	0,029	50
9/20	M32	8,5	33	20051320	0,045	25
15/27	M40	8,5	40	20051400	0,085	10
21/33	M50	9,5	50	20051500	0,137	5
30/45	M63	10,5	65	20051630	0,278	5

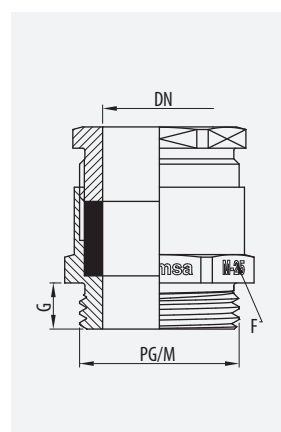

Prensaestopas Hexadin-M-L

Hexadin-M-L Cable Gland

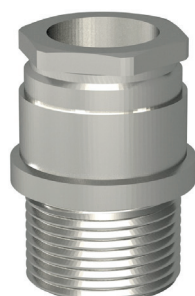

DN		G		LN	kg/u	
6/8	PG 7	15,0	14	20060007	0,011	50
4/10	PG 9	15,0	18	20060009	0,016	50
6,5/12	PG11	15,0	20	20060011	0,024	50
6,5/13	PG13	15,0	22	20060013	0,028	50
6,5/16	PG16	15,0	24	20060016	0,036	50
9/20	PG21	15,0	30	20060021	0,054	25
17/28	PG29	15,0	40	20060029	0,101	25
23/34	PG36	15,0	50	20060036	0,153	10
35/46	PG48	15,0	64	20060048	0,305	5

LN+NBR		-25°/+60°	54	OK

ETIM:EC000441

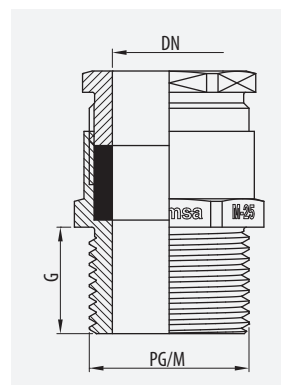

Prensaestopas IRIS-M

IRIS-M Cable Gland



ETIM:EC000441

DN		G	L		LN	kg/u	
3/ 6,5	PG 7	6,0	28,0	14	21030007	0,017	50
4/ 8	PG 9	6,0	29,0	17	21030009	0,024	50
5/10	PG11	6,0	30,5	20	21030011	0,027	50
6/12	PG13	6,5	33,0	22	21030013	0,030	50
10/14	PG16	6,5	34,5	24	21030016	0,037	50
13/18	PG21	7,0	38,5	30	21030021	0,057	50
18/25	PG29	8,0	46,0	40	21030029	0,120	25
22/32	PG36	10,0	53,0	50	21030036	0,202	10
30/38	PG42	12,0	59,0	57	21030042	0,235	5
34/44	PG48	14,0	62,0	64	21030048	0,347	5
3/ 6,5	M12	6,0	28,0	14	21031120	0,015	50
4/ 8	M16	7,0	30,0	18	21031160	0,025	50
6/12	M20	8,0	45,0	22	21031200	0,041	50
10/14	M25	8,0	36,0	27	21031250	0,056	25
13/18	M32	9,0	40,5	34	21031320	0,098	25
18/25	M40	9,0	47,0	43	21031400	0,155	10
22/32	M50	9,0	52,0	55	21031500	0,286	5
34/44	M63	14,0	62,0	68	21031630	0,390	5

NBR		-20°/+100°	68	OK

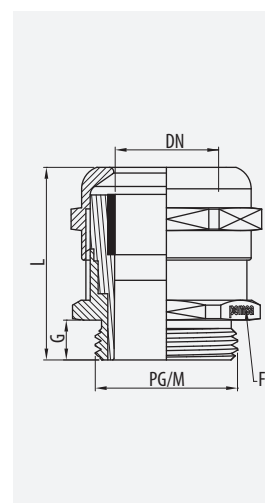



Prensaestopas IRIS-M EMC

IRIS-M EMC Cable Gland

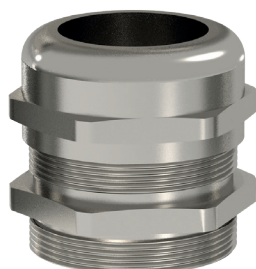

LN+NBR	-20°/+100°	68	OK	

ETIM:EC000441

DN		L	G		LN	kg/u	
3/6,5	PG7	22	10	25	21034007	0,017	100
4/8	PG9	23	10	27	21034009	0,019	50
5/10	PG11	24,5	10	28	21034011	0,025	50
6/12	PG13	26,5	10	29,5	21034013	0,030	50
10/14	PG16	28	10	30,5	21034016	0,037	50
13/18	PG21	31,5	12	32	21034021	0,063	25
18/25	PG29	38	12	39	21034029	0,120	20
22/32	PG36	43	14	47	21034036	0,234	10
30/38	PG42	47	18	49	21034042	0,253	5
34/44	PG48	48	18	52	21034048	0,347	5
3/6,5	M12	22	6	14	21035120	0,013	100
4/8	M16	23	7	18	21035160	0,019	50
6/12	M20	26,5	8	22	21035200	0,027	50
10/14	M25	28	8	27	21035250	0,042	25
13/18	M32	31,5	9	36	21035320	0,073	20
18/25	M40	38	9	46	21035400	0,146	10
22/32	M50	43	9	55	21035500	0,257	5
34/44	M63	48	14	70	21035630	0,398	5

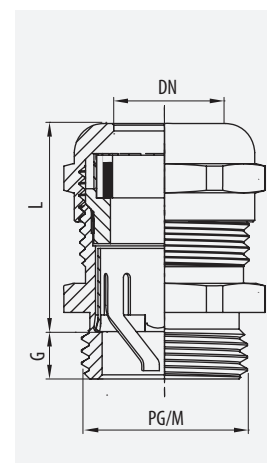

Prensaestopas HSK-M

HSK-M Cable Gland



LN+NBR	-40°/+100°	68	OK	

ETIM:EC000441

DN		G	L		LN	kg/u	
3/6,5	PG 7	5,0	24,0	14	22050007	0,011	50
4/8	PG 9	6,0	27,0	17	22050009	0,018	50
5/10	PG11	6,0	28,0	20	22050011	0,024	50
6/12	PG13	6,5	30,5	22	22050013	0,029	50
10/14	PG16	6,5	29,5	24	22050016	0,032	50
13/18	PG21	7,0	31,0	30	22050021	0,052	25
18/25	PG29	8,0	37,0	40	22050029	0,097	25
22/32	PG36	8,0	43,0	50	22050036	0,159	10
37/44	PG48	10,0	48,0	64	22050048	0,300	5
3/ 6,5	M12	6,5	25,5	14	22051120	0,018	50
4/ 8	M16	6,0	27,0	17	22051160	0,018	50
5/10	M16	6,0	28,0	20	22051161	0,018	50
6/12	M20	6,0	29,0	22	22051200	0,029	50
10/14	M20	6,0	30,0	24	22051201	0,029	50
13/18	M25	7,0	33,0	30	22051250	0,052	25
18/25	M32	8,0	39,0	40	22051320	0,097	25
22/32	M40	8,0	45,0	50	22051400	0,167	10
32/38	M50	9,0	46,0	57	22051500	0,218	5
37/44	M63	10,0	48,0	64	22051630	0,290	5

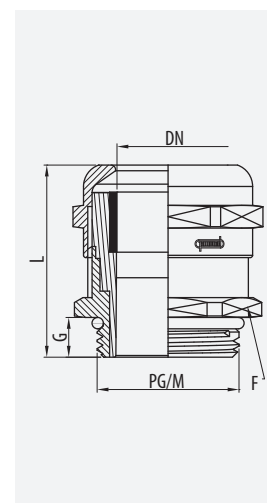

Tuerca TCP

TCP Nut

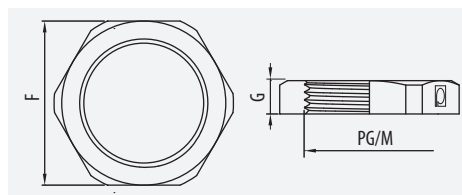

ETIM:EC000129

PA6	-25°/+105°	OK	

	L		RAL 7001	RAL 7035	RAL 9005	kg/u	
PG 7	5	19	40026007	40020007	40024007	0,001	100
PG 9	5	22	40026009	40020009	40024009	0,002	100
PG11	5	24	40026011	40020011	40024011	0,001	100
PG13	6	27	40026013	40020013	40024013	0,002	100
PG16	6	30	40026016	40020016	40024016	0,003	100
PG21	7	36	40026021	40020021	40024021	0,003	100
PG29	7	46	40026029	40020029	40024029	0,006	50
PG36	8	60	40026036	40020036	40024036	0,013	25
PG48	8	70	40026048	40020048	40024048	0,014	25
M12	5	18	40027120	40021120	40025120	0,001	100
M16	5	22	40027160	40021160	40025160	0,001	100
M20	6	26	40027200	40021200	40025200	0,002	100
M25	6	32	40027250	40021250	40025250	0,005	100
M32	7	41	40027320	40021320	40025320	0,005	50
M40	7	50	40027400	40021400	40025400	0,007	25
M50	8	60	40027500	40021500	40025500	0,010	25
M63	8	75	40027630	40021630	40025630	0,016	25



Tapón TPK

TPK Cap

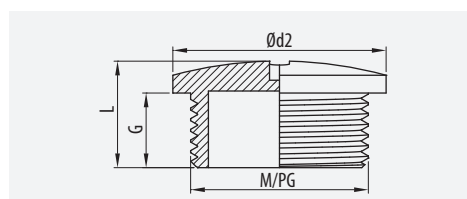

	Ød2	G	L	RAL 7035	kg/u	
PG 7	15	6	8,0	44020007	0,001	100
PG 9	19	6	9,0	44020009	0,002	100
PG11	22	6	9,0	44020011	0,002	100
PG13	25	6	8,5	44020013	0,002	100
PG16	27	6	8,5	44020016	0,003	100
PG21	33	8	12,0	44020021	0,005	100
PG29	44	8	12,0	44020029	0,007	50
PG36	55	10	15,0	44020036	0,013	25
M12	15	6	8,5	44021120	0,001	100
M16	20	7	10,0	44021160	0,002	100
M20	24	7	10,0	44021200	0,005	100
M25	30	10	14,0	44021250	0,007	100
M32	37	10	14,0	44021320	0,013	50
M40	48	10	15,0	44021400	0,018	50
M50	56	13	18,5	81000215	0,015	25
M63	69	15	19,0	81000216	0,010	10

	M PA6		-25°/+90°		IP 54		OK
--	-------	--	-----------	--	-------	--	----

ETIM: EC002316

Reducción R-H

R-H Reducer

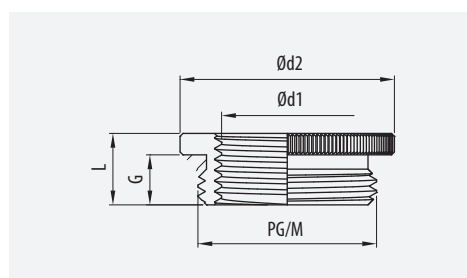

	Ød1	Ød2	G	L	LN	kg/u	
M16	M12	18,0	6,0	8,5	42001612	0,010	100
M20	M16	24,0	6,5	9,0	42002016	0,007	100
M25	M16	30,0	7,0	10,0	42002516	0,030	50
M25	M20	30,0	7,0	10,0	42002520	0,020	50
M32	M20	39,0	8,0	11,5	42003220	0,050	50
M32	M25	39,0	8,0	11,5	42003225	0,030	50
M40	M25	43,0	8,0	11,5	42004025	0,040	25
M40	M32	43,0	9,0	12,5	42004032	0,040	25
M50	M32	57,0	10,0	14,0	42005032	0,120	10
M50	M40	57,0	10,0	14,0	81000213	0,094	10
PG 9	PG 7	17,0	6,0	8,5	81000194	0,006	100
PG11	PG 7	20,0	6,0	8,5	81000195	0,010	100
PG11	PG 9	20,0	6,0	8,5	81000196	0,005	100
PG13	PG 9	22,0	6,5	9,0	81000197	0,011	100
PG13	PG11	22,0	6,5	9,0	81000198	0,004	100
PG16	PG 9	24,0	6,5	9,5	81000199	0,007	100
PG16	PG11	24,0	6,5	9,5	81000200	0,010	100
PG16	PG13	24,0	6,5	9,5	81000201	0,006	100
PG21	PG11	30,0	7,0	10,0	81000202	0,028	50
PG21	PG13	30,0	7,0	10,0	81000203	0,024	50
PG21	PG16	30,0	7,0	10,0	81000204	0,019	50
PG29	PG16	39,0	8,0	11,5	81000205	0,065	50
PG29	PG21	39,0	8,0	11,5	81000206	0,042	50
PG36	PG21	50,0	9,0	12,5	81000207	0,117	25
PG36	PG29	50,0	9,0	12,5	81000208	0,070	25
PG42	PG29	57,0	10,0	14,0	81000209	0,146	10
PG42	PG36	57,0	10,0	14,0	81000210	0,070	10
PG48	PG36	64,0	10,0	14,0	81000211	0,074	10
PG48	PG42	64,0	10,0	14,0	81000212	0,065	10

	M LN		-45°/+150°		IP 54		OK
--	------	--	------------	--	-------	--	----

ETIM: EC000938



Tuerca TCM

TCM Nut



PG	G	Wrench	LN	kg/u	Box
PG 7	2,8	15	40010007	0,002	100
PG 9	2,8	18	40010009	0,002	100
PG11	3,0	21	40010011	0,003	100
PG13	3,0	23	40010013	0,003	100
PG16	3,0	26	40010016	0,005	100
PG21	3,5	32	40010021	0,007	100
PG29	4,0	41	40010029	0,013	50
PG36	5,0	51	40010036	0,021	25
PG42	5,0	60	40010042	0,030	25
PG48	5,5	64	40010048	0,034	25
M12	2,8	15	40011120	0,002	100
M16	2,8	19	40011160	0,003	100
M20	3,0	24	40011200	0,004	100
M25	3,5	30	40011250	0,009	100
M32	4,0	36	40011320	0,011	50
M40	5,0	46	40011400	0,019	25
M50	5,0	60	40011500	0,026	25
M63	6,0	70	40011630	0,055	25

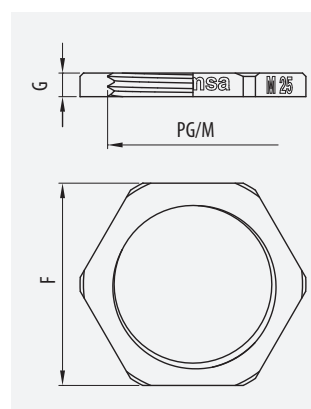

LN	-45°/+150°	OK
----	------------	----

ETIM:EC000129

Ampliación E-MS

E-MS Enlarger

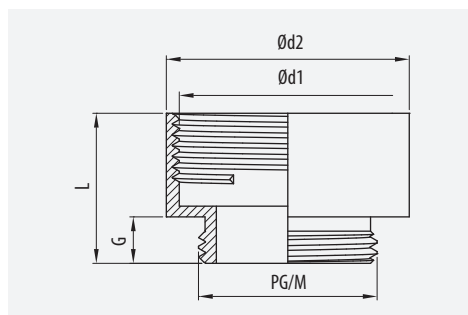

PG	Ød1	Ød2	G	L	LN	kg/u	Box
PG 7	PG 9	17	5,0	15,0	42020709	0,007	100
PG 9	PG11	20	6,0	16,5	42020911	0,009	100
PG 9	PG13	22	6,0	17,5	42020913	0,010	100
PG11	PG13	22	6,0	17,5	42021113	0,012	100
PG11	PG16	24	6,0	18,5	42021116	0,013	100
PG13	PG16	24	6,5	19,0	42021316	0,012	100
PG16	PG21	30	6,5	21,0	42021621	0,024	50
PG21	PG29	39	7,0	23,0	42022129	0,038	50
PG29	PG36	50	8,0	28,0	42022936	0,077	25
M12	M16	18	5,0	15,0	42051216	0,010	100
M16	M20	22	6,0	17,5	42051620	0,010	100
M20	M25	27	6,5	19,0	42052025	0,020	50
M25	M32	34	8,0	20,5	42052532	0,030	50
M32	M40	42	7,0	23,0	42053240	0,050	25
M40	M50	53	9,0	31,0	42054050	0,160	10
M50	M63	65	9,5	24,0	42055063	0,160	10



LN	-45°/+150°	OK
----	------------	----

ETIM:EC000938

Adaptador RE-MS

RE-MS Adaptor

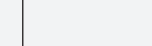
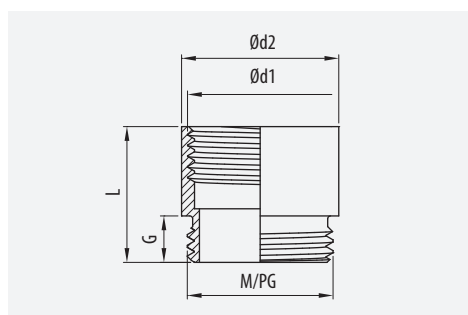

PG	Ød1	Ød2	G	L	LN	kg/u	Box
M16	PG 9	20	6,0	16,5	43001609	0,020	100
M20	PG11	22	6,5	19,0	43002011	0,020	100
M20	PG13	22	6,5	19,0	43002013	0,010	100
M20	PG16	24	6,5	19,0	43002016	0,020	100
M25	PG16	28	6,5	19,0	43002516	0,050	50
M25	PG21	30	6,5	21,0	43002521	0,020	50
M32	PG21	35	7,0	21,0	81000214	0,045	100
M32	PG29	39	7,0	23,0	43003229	0,050	25
PG 9	M16	20	6,0	16,5	43010916	0,020	100
PG11	M20	22	6,5	19,0	43011120	0,020	100
PG13	M20	22	6,5	19,0	43011320	0,020	100
PG16	M25	27	6,5	21,0	43011625	0,040	50



LN	-45°/+150°	OK
----	------------	----

ETIM:EC000938



Tapón TPM

TPM Cap

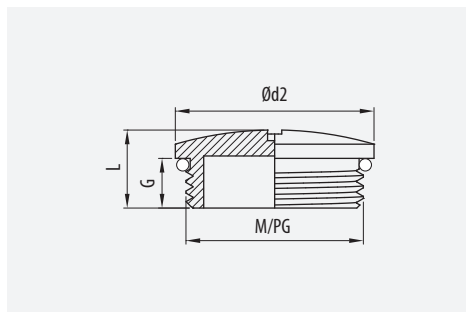

	Ød2	G	L	LN	kg/u	
PG 7	14	5,25	8,0	44010007	0,004	100
PG 9	17	6,00	9,0	44010009	0,005	100
PG11	20	6,00	9,0	44010011	0,008	100
PG13	22	6,50	9,5	44010013	0,009	100
PG16	24	6,50	9,5	44010016	0,013	100
PG21	30	7,00	11,0	44010021	0,024	100
PG29	39	8,00	12,0	44010029	0,036	50
PG36	50	9,00	15,0	44010036	0,082	25
PG42	57	10,00	16,0	44010042	0,107	25
PG48	64	10,00	16,0	44010048	0,119	10
M12	14	5,00	7,0	44011120	0,005	100
M16	18	6,00	8,0	44011160	0,008	100
M20	22	6,50	8,5	44011200	0,013	100
M25	27	7,00	10,0	44011250	0,024	100
M32	34	8,00	11,0	44011320	0,050	50
M40	44	9,00	13,0	44011400	0,093	25
M50	54	10,00	14,5	44011500	0,136	25
M63	67	10,00	15,0	44011630	0,190	10



	M	°C	IP	
LN		-25 ⁰ /+150 ⁰ C	68	54



ETIM:EC002316

Junta Plana

Flat Ring

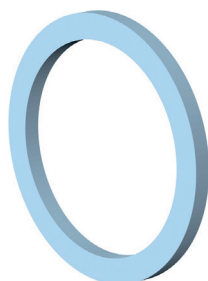

	Ød2	L	RAL 5024	kg/u	
PG 7	16,5	2	39090007	0,001	500
PG 9	19	2	39090009	0,001	500
PG11	22,5	2	39090011	0,002	500
PG13	25	2	39090013	0,003	500
PG16	27	2	39090016	0,003	500
PG21	33,5	2	39090021	0,005	500
PG29	43,5	2	39090029	0,009	250
PG36	55	2	39090036	0,018	100
PG48	69	2	39090048	0,025	50
M12	16	2	39090112	0,001	500
M16	20	2	39090116	0,002	500
M20	25	2	39090120	0,003	500
M25	31	2	39090125	0,003	500
M32	38	2	39090132	0,005	250
M40	48	2	39090140	0,009	100
M50	58	2	39090150	0,018	50
M63	72	2	39090163	0,025	50

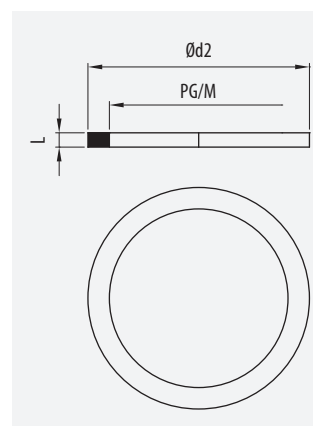

	M	°C	IP	
NBR		-25 ⁰⁰ /+120	68	OK



ETIM:EC000098



Junta Tórica

O-Ring



	$\odot \varnothing 2$	C	RAL 9005	kg/u	
PG 7	9,0	1,5	39096007	0,001	500
PG 9	12,0	1,5	39096009	0,001	500
PG11	16,0	1,5	39096011	0,001	500
PG13	17,2	1,8	39096013	0,001	100
PG16	22,0	2,0	39096016	0,002	500
PG21	29,0	2,0	39096021	0,003	500
PG29	33,0	2,0	39096029	0,004	250
PG36	43,0	2,0	39096036	0,006	100
PG48	55,0	2,0	39096048	0,007	50
M12	9,0	1,5	39096112	0,001	500
M16	12,0	1,5	39096116	0,002	500
M20	17,2	1,8	39096120	0,002	500
M25	22,0	2,0	39096125	0,003	500
M32	29,0	2,0	39096132	0,004	250
M40	35,0	2,0	39096140	0,005	50
M50	43,0	2,0	39096150	0,066	50
M63	55,0	2,0	39096163	0,007	50

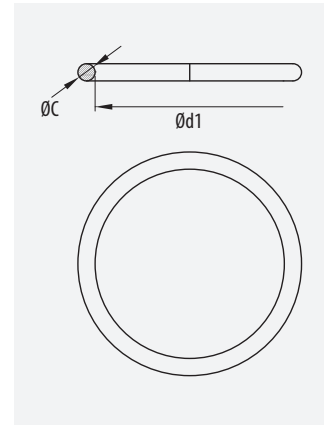

	NBR	-25°/+120°	68	OK

ETIM:EC000098

Cinta Helicoidal

Spiral Tape

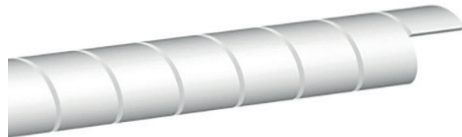

	DN	$\odot \varnothing 1$	$\odot \varnothing 2$	RAL 9010	RAL 9005	kg/u	
3/12	2,5	4	91011030	91012030	0,007	500	
6/40	4	6	91021060	91022060	0,014	250	
8/60	5,4	8	91031080	91032080	0,026	125	
10/90	9,2	12	91041109	91042109	0,039	50	

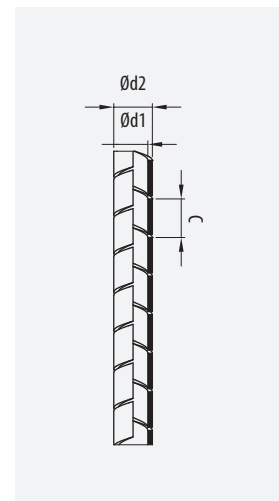

	PE	-45°/+90°	OK

ETIM:EC002604





GUÍA DE SOLUCIONES
VERTICALES SECTORIALES
VERTICAL SOLUTIONS GUIDE BY SECTOR





soluciones
solutions

pemsa



Terciario Construcción Tertiary Building

Aplicaciones / Applications



Edificios de Oficinas, Aeropuertos, Estaciones, Hospitales, Centros Educativos, Centros comerciales, de ocio, Teatros.

Office buildings, airports, railway stations, hospitals, educational centres, shopping centres, leisure centres, theatres.

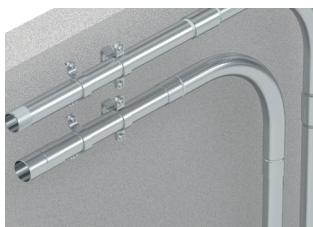

Instalaciones de tubos en superficie con altos requisitos de mecánicos de protección según ITC-BT 21

Surface conduit installations with high requirements for mechanical protection.

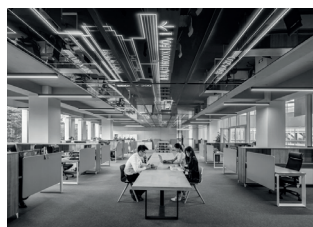

Instalaciones en falsos techos, huecos de la construcción o empotradas, según ITC-BT 21

Installations in false ceilings, holes in the building, or recessed in the wall.



Instalación de Pública concurrencia con altos requisitos de seguridad, Libre de halógenos, según ITC-BT 28

Public facilities with high safety requirements, halogen-free, etc

Ventajas / Advantages

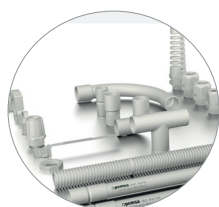

Amplia gama de producto y accesorios que complementan la instalación.

Wide range of products and accessories that complement the installation.

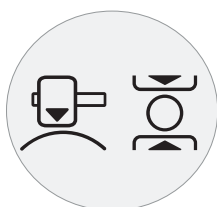

Materiales con altos requisitos mecánicos, Compresión e Impacto.

Materials with high mechanical requirements compression and impact strengths

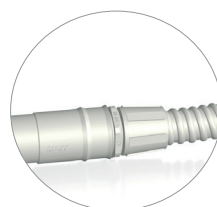

Gama completa en Gris Claro RAL 7035. Alta Componente estética.

Complete range in Light Grey RAL 7035. High Aesthetic Component.



Materiales Libres de Halógenos para altos requisitos de seguridad.

Halogen free raw materials for high safety requirements.

Sistema de tubos <i>Conduit system</i>	DN		Color		Racor adecuado <i>Suitable connector</i>		Color	
---	----	--	-------	--	---	--	-------	--

Tubo RPVC 1250 / RPVC 1250 Conduit

DN16-DN63	PVC	RAL 7035	09
-----------	-----	----------	----



Manguito RPVC / RPVC Coupler

DN16-DN63	PVC+ABS	RAL 7035	36
-----------	---------	----------	----

Racor a Cajas RPVC

DN16-DN63	PVC+ABS	RAL 7035	37
-----------	---------	----------	----

Tubo RLH 1250 / RLH 1250 Conduit

DN16-DN63	PC+ABS	RAL 7035	10
-----------	--------	----------	----



Manguito RLH / RLH Coupler

DN16-DN63	PC+ABS	RAL 7035	08
-----------	--------	----------	----

**Racor a Cajas RLH IP65 /
RLH IP 65 Coupler Boxes**

DN16-DN63	PC+ABS	RAL 7035	
-----------	--------	----------	--

Tubo CLH / CLH Conduit

DN16-DN63	PP	RAL 7035	10
-----------	----	----------	----

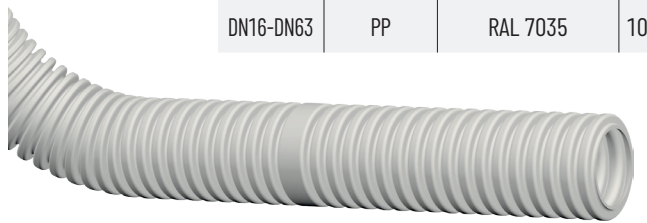

Racor Cajas RLH / RLH Coupler Boxes

DN16-DN63	PC+ABS	RAL 7035	09
-----------	--------	----------	----

Derivación T RLH / RLH Tee

DN16-DN63	PC+ABS	RAL 7035	
-----------	--------	----------	--

Tubo TFA y TM-PVC RAL 7035 / TFA & TM-PVC RAL 7035 Conduit

DN7-DN48	PVC + PG	RAL 7035 RAL 7011	
----------	----------	----------------------	--

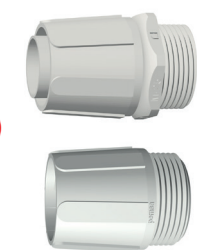
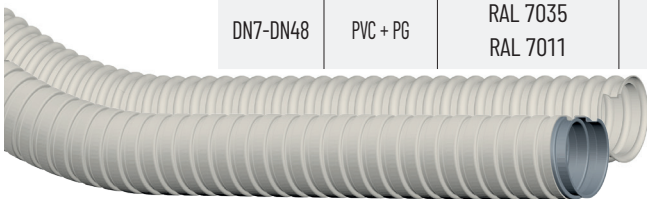

Racor RGp 7035 / RGp 7035 Coupler Boxes

M12-M63 PG07-PG48	PA6	RAL 7035 RAL 7001	
----------------------	-----	----------------------	--

Racor P 7035 / P 7035 Coupler Boxes

M12-M63 PG07-PG48	PA6	RAL 7035 RAL 7001	
----------------------	-----	----------------------	--

Tubo RL / RL Conduit

DN16-DN63	EZ	Metal	14
-----------	----	-------	----

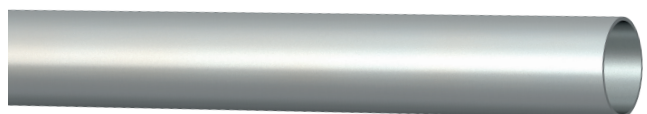

Manguito RL / RL Coupler

DN16-DN63	EZ	Metal	14
-----------	----	-------	----

**Manguito Acoplamiento RL /
Connection Coupler**

DN16-DN63	EZ	Metal	15
-----------	----	-------	----

Amplia Gama de Accesorios / Wide range of accessories

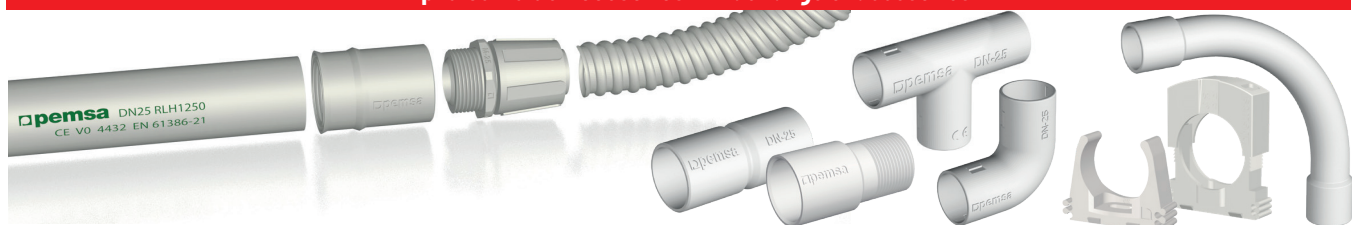



soluciones
solutions

pemsa



Industria General
General Industry

Aplicaciones / Applications



Protección de cableado para conexión de máquinas.
Cable protection for machine connections.

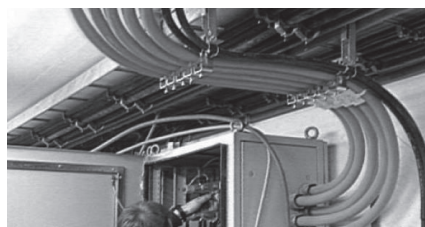

Instalaciones generales de potencia y datos en fábrica.
General power and data installations in the factory

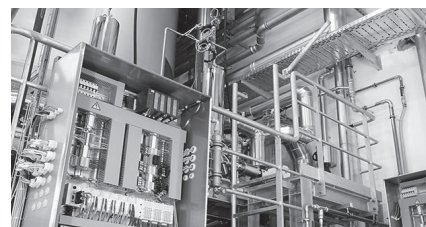

Instalaciones industriales con requisitos de mecánicos y amplio rango de temperaturas.
Industrial installations with mechanical requirements and a wide temperature range.

Ventajas / Advantages



Amplia gama de producto.
Wide range of accessories.

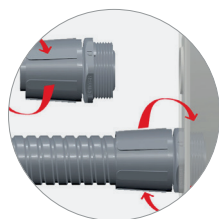

Racores tipo giratorio que facilitan la instalación de los tubos.
Swivel-type fittings that facilitate the installation of the conduits.



Protección y alta estanqueidad en equipos, IP68 IP65.
Protection and high grade of sealing, IP68, IP65, IP54.

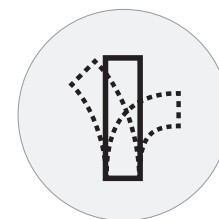

Alta flexibilidad que se adapta a partes móviles en la fabricación.
High flexibility that adapts to moving parts in manufacturing.

Sistema de tubos <i>Conduit system</i>	DN		Color		Racor adecuado <i>Suitable connector</i>			Color	
---	----	--	-------	--	---	--	--	-------	--

Tubo TFA / TFA Conduit

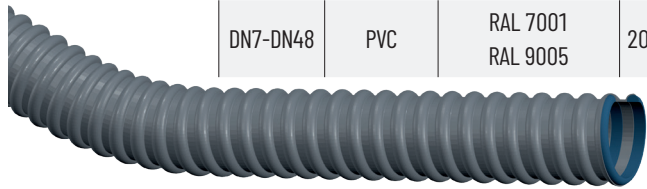

DN7-DN48	PVC	RAL 7001 RAL 9005	20
----------	-----	----------------------	----



Racor P / P Connector

M12-M63 PG07-PG48	PA6	RAL 7001	21
----------------------	-----	----------	----



Racor RGp Giratorio / RGp Swivel Connector

M12-M63 PG07-PG48	PA6	RAL 7001	21
----------------------	-----	----------	----

Tubo TM-PVC / TM-PVC Conduit

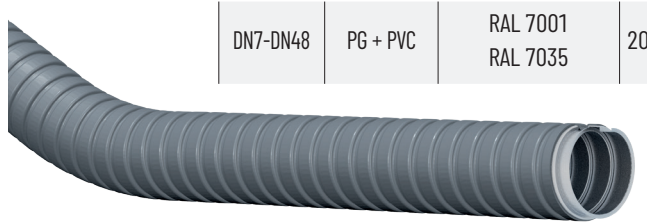

DN7-DN48	PG + PVC	RAL 7001 RAL 7035	20
----------	----------	----------------------	----



Racor RM / RM Connector

M12-M63 PG07-PG48	LN	Metal	22
----------------------	----	-------	----

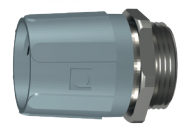

Racor RGm / RGM Swivel Connector

M12-M63 PG07-PG48	PA6	RAL 7001	22
----------------------	-----	----------	----

Tubo ECOFLEX / ECOFLEX Conduit

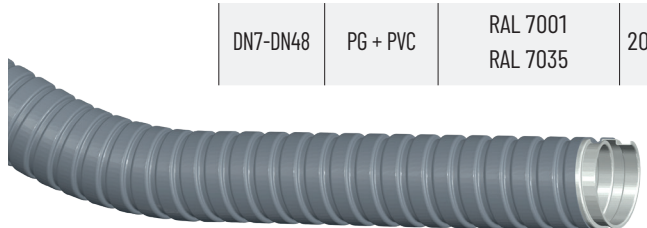

DN7-DN48	PG + PVC	RAL 7001 RAL 7035	20
----------	----------	----------------------	----



Racor RM / RM Connector

M12-M63 PG07-PG48	LN	Metal	22
----------------------	----	-------	----



Racor RGp Giratorio / RGp Swivel Connector

M12-M63 PG07-PG48	PA6	RAL 7001	21
----------------------	-----	----------	----

Tubo LG-PA / LG-PA Conduit

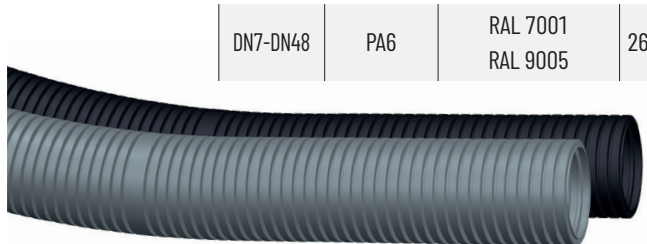

DN7-DN48	PA6	RAL 7001 RAL 9005	26
----------	-----	----------------------	----



Racor PA6 / PA6 Connector

M12-M63 PG07-PG48	PA6	RAL 7001	28
----------------------	-----	----------	----

Tubo RL / RL Conduit



DN16-DN63	EZ	Metal	14
-----------	----	-------	----

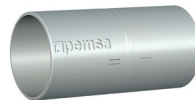

Manguito RL / RL Coupler

DN16-DN63	EZ	Metal	14
-----------	----	-------	----



Manguito Acomplamiento RL / Connection Coupler

DN16-DN63	EZ	Metal	15
-----------	----	-------	----

		Color	
--	--	-------	--

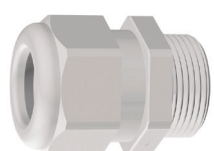

Prensaestopas IRIS-P / IRIS-P Cable Gland

M12-M63 PG07-PG48	PA6 + TPV	RAL 7035 RAL 7001 RAL 9005	35
----------------------	-----------	----------------------------------	----

		Color	
--	--	-------	--



Prensaestopas IRIS-M / IRIS-M Cable Gland

M12-M63 PG07-PG48	LN + TPV	Metal	36
----------------------	----------	-------	----



soluciones
solutions

pemsa



Fotovoltaica
Autoconsumo
Renovables
Photovoltaic/
Renewables

Aplicaciones / Applications

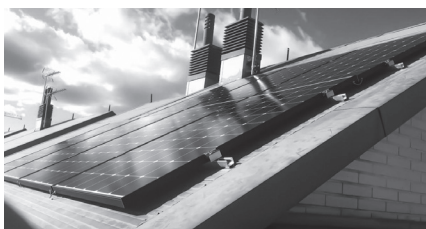

Protección y conducción de cableado en instalaciones de Cubiertas Fotovoltaicas y Autoconsumo.

Cable management and protection in solar roofs and self-consumption installations.



Protección y conducción de cableado en Plantas Solares de Estructura fija o Seguidores de Eje.

Management and protection of cables in Solar Fixed Structure plants or Shaft Trackers.



Instalaciones y aplicaciones en Generadores Eólicos, Centrales Termosolares, Biomasa, etc.

Installations and applications in Wind turbines, Solar Thermal Power Plants, Biomass, etc.

Ventajas / Advantages

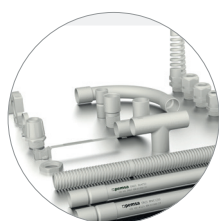

Amplia gama de producto.
Wide range of accesories.



Excelente comportamiento frente a la Radiación Ultravioleta y la Intemperie
Excellent performance against UV radiation and outdoor applications



Protección y alta estanqueidad, IP68, IP65, IP54
Protection and high grade of sealing, IP68, IP65, IP54.



Alto grado de protección mecánica y Resistencia a la corrosión
High range of mechanical protection and corrosion resistance

Sistema de tubos <i>Conduit system</i>	DN		Color	
---	----	--	-------	--

Tubo Poliamida LG-PA y ST-PA / LG-PA & ST-PA Flexible Conduit

	DN7-DN48	PA6	RAL 7001 RAL 9005	26
--	----------	-----	----------------------	----

Racor adecuado <i>Suitable connector</i>			Color	
---	--	--	-------	--

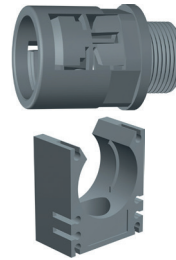

Racor REP / Connector REP

M12-M63 PG07-PG48	PA6	RAL 7001	27
----------------------	-----	----------	----

Soporte Tubo / Conduit Clips

M12-M63 PG07-PG48	PA6	RAL 7001	30
----------------------	-----	----------	----

Tubo RPVC 1250 / RPVC 1250 Conduit

	DN16-DN63	PVC	RAL 7035	09
--	-----------	-----	----------	----



Manguito RPVC / RPVC Coupler

DN16-DN63	PVC+ABS	RAL 7035	09
-----------	---------	----------	----

Racor a Cajas RPVC / Coupler Boxes RLH

DN16-DN63	PVC+ABS	RAL 7035	09
-----------	---------	----------	----

Tubo RLH 1250 / RLH 1250 Conduit

	DN16-DN63	PC+ABS	RAL 7035	08
--	-----------	--------	----------	----



Manguito RLH / RLH Coupler

DN16-DN63	PC+ABS	RAL 7035	10
-----------	--------	----------	----

**Racor a Cajas RLH IP65 /
RLH IP 65 Coupler Boxes**

DN16-DN63	PC+ABS	RAL 7035	
-----------	--------	----------	--

Tubo RRG y RLGC / RRG & RLGC Conduit

	DN16-DN63	PG	Metal	16
--	-----------	----	-------	----



Manguito RRG / RRG Coupler

M16-M63	PG	Metal	17
---------	----	-------	----

Manguito RLGC / RLGC Coupler

DN16-DN63	PG	Metal	16
-----------	----	-------	----

		Color	
--	--	-------	--

Prensaestopas IRIS-P / IRIS-P Cable Gland

	M12-M63 PG07- PG48	PA6 + TPV	RAL 7035 RAL 7001 RAL 9005	35
--	--------------------------	-----------	----------------------------------	----

		Color	
--	--	-------	--

Prensaestopas IRIS-M / IRIS-M Cable Gland

	M12-M63 PG07- PG48	LN + TPV	Metal	36
--	--------------------------	----------	-------	----

Prensaestopas HSK-K / HSK-K Cable Gland

	M12-M63 PG07- PG48	PA6 + NBR	RAL 7035 RAL 9005	35
--	--------------------------	-----------	----------------------	----

Prensaestopas HSK-M / HSK-M Cable Gland

	M12-M63 PG07- PG48	LN + NBR	Metal	37
--	--------------------------	----------	-------	----

Iconografía / Iconography / Iconographie / Iconografía
Características de Tubos / Conduits features

DN Diámetro Nominal / <i>Nominal Width</i>	Codificación según Norma internacional de Tubos IEC 61386 <i>International Standard of Conduits Code IEC 61386</i>	Clasificación IP / <i>IP Classification</i>
$\varnothing d_1$ Diámetro interior / <i>Inside diameter</i>	Resistencia a la Compresión <i>Compression Strength</i>	No propagador de la llama <i>Flame retardant</i>
$\varnothing d_2$ Diámetro exterior / <i>Outside diameter</i>	Resistencia al Impacto <i>Impact Strength</i>	Comportamiento Radiación Ultra Violeta <i>Ultra Violet Radiation behaviour</i>
Radio de Curvatura / <i>Bending radius</i>	Temperaturas de trabajo. <i>Working temperature range</i>	Flexibilidad / <i>Flexibility</i>
Tipo de Rosca / <i>Thread Size</i>		Reduce el tiempo de instalación un 45% / <i>45% Time Savings</i>
Llave de apriete necesaria <i>Torque wrench</i>		

Homologaciones / Approvals

Norma Internacional de Tubos IEC 61386 / <i>Conduit International Standard IEC 61386</i>	Conformidad con Directiva RoHS 2002/95/CE / <i>Compliance with Directive RoHS 2002/95/CE</i>	Certificación UL Certified <i>UL Certified Approval</i>
Marcado N de AENOR <i>AENOR N Mark</i>	Ensayo Resistencia al Fuego E90 según DIN 4102-12 <i>E90 Fire Resistance Test acc. to DIN 4102-12 Standard</i>	Certificación Canadiense CSA <i>CSA Canadian Approval</i>
Conforme NEMA VE-1 <i>Acc. to NEMA VE-1 Standard</i>	Certificación según Norme Française <i>Approval acc. to Norme Française</i>	Certificación Alemana VDE <i>VDE German Approval</i>
Conformidad CE con Directiva 2006/95 CE <i>Acc. to Directive 2006/95 CE</i>	Homologación Deutsche Bahn <i>Deutsche Bahn Approval</i>	Certificación Germanischer Lloyd <i>Germanischer Lloyd Approval</i>
	Certificación Aplicaciones Marinas DNV <i>Marine applications DNV Approval</i>	Certificación Rusa GOST <i>Russian GOST Approval</i>
Certificación Retie <i>Retie approval</i>	Certificación UL Listed <i>UL Listed Approval</i>	Certificación Áreas explosivas ATEX <i>ATEX Hazardous Areas Approval</i>
Libre de Halógenos según EN 50267-2-1 <i>Halogen free acc. to EN 50267-2-1</i>		



Pemsa Cable Management, S.A.



Tel.: +34 91 802 01 20



info@pemsa-rejiband.com



C/ Galileo Galilei 22 - 24. P.E. La Garena
28806, Alcalá de Henares. Madrid. España



UK



1 Sussex Avenue
Leeds LS10 2LF
Tel.: +44 113 277 9090
sales@pemsa.co.uk
www.pemsa.co.uk

Portugal



Estrada de Polima, 1007 - 2ªK
2785-543 São Domingos de
Rana. Portugal
Tel.: +351 21 4445725
pemsa.portugal@pemsa-
rejiband.com

France



12, Rue de la Closerie, ZI de
Clos aux pois
Bat G. 91090 LISSES. France
Tel.: +33 01 60 86 75 65
service-client@pemsa.fr
www.pemsa.fr

LATAM



Via Funza - Siberia, Km 1,5
Parque Ind. VIC - Bodega 1.
FUNZA (Bogotá) - COLOMBIA
Tel.: +57 1 823 7502
customerservice@pemsa.com
www.pemsa.com.co