



The Architect's Guide

to Sun Control Products

LEADERSHIP IN ENERGY AND ENVIRONMENTAL DESIGN™

LEED® GUIDE

Ruskin® engineer aluminum sunshades that can contribute to LEED® certification.

LEED® EA Credit 1, Optimize Energy Performance

Preserving energy includes reducing solar heat gain in the summer months and directing sunlight to be used effectively in the winter months.

LEED® MR Credits 4.1 and 4.2, Recycled Content

Ruskin manufactures aluminum sunshades that contain high percentages of both post-consumer and pre-consumer recycled content. Contact Ruskin for up-to-date recycled content.

LEED® MR Credits 5.1 and 5.2, Regional Materials

These credits are applicable to job locations within the 500 mile radius of a Ruskin factory. Sunshades can be transported beyond the 500 mile radius without credit qualification. Contact Ruskin for manufacturing locations.

LEED® IEQ Credits 8.1 and 8.2, Daylight and Views

Ruskin sunshades control glare and increase lighting quality while still creating a connection to the outdoor space.



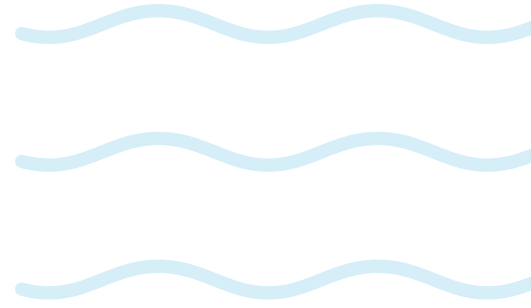

CONTENT

02	LEED® Guide
04	Frequently asked questions
06	Designing a sunshade
08	How to shade correctly
10	Projects
20	Curved blades
21	Installation brackets
22	Mitered corners
23	<i>Ruskin</i> ® finishes
23	Specifications

FREQUENTLY ASKED QUESTIONS

Q: Can a *Ruskin*® sunshade benefit my design by making it more sustainable?

A: Not only are sunshades a great way to put your mark on a building as an architect, but they are also an ideal way to accumulate LEED® points.

Q: Does Ruskin offer AIA continuing education courses online?

A: Yes, visit www.ruskin.com for the latest continuing education information.

Q: What finish types are available on sunshades?

A: Ruskin offers endless possibilities of color in standard 2-coat 50 percent polyvinylidene fluoride (PVDF) and 70 percent PVDF, as well as our Pearledize 50 and 70 (2-coat mica). Clear and Color Anodize finishes are also available, but highly discouraged due to the variation in metal alloys.

Q: What if I would like to incorporate a design not shown in this brochure?

A: Please contact Ruskin for help with your specifications in relation to our designs.

Q: What are intermediate outriggers?

A: Intermediate outriggers are a great solution when blades span a distance beyond their maximum structural limits. To function correctly, they require front and rear fascias.

Q: What does Ruskin recommend with regard to attachment brackets?

A: Ruskin has set configurations that will save time and money but can design an attachment to fit most any need

Q: Welding vs. Mechanical Fastening, which is better?

A: Ruskin's standard manufacturing practice is to use mechanical fasteners. This is a cost saving to our customers.

Q: Can Ruskin provide stamped, structural calculations by a professional engineer in my state?

A: Yes we can! We have design engineers in-house that perform the calculations for review by a professional engineer in the applicable state to check and stamp. Please call your local representative from Ruskin for more details.



DESIGNING A SUNSHADE

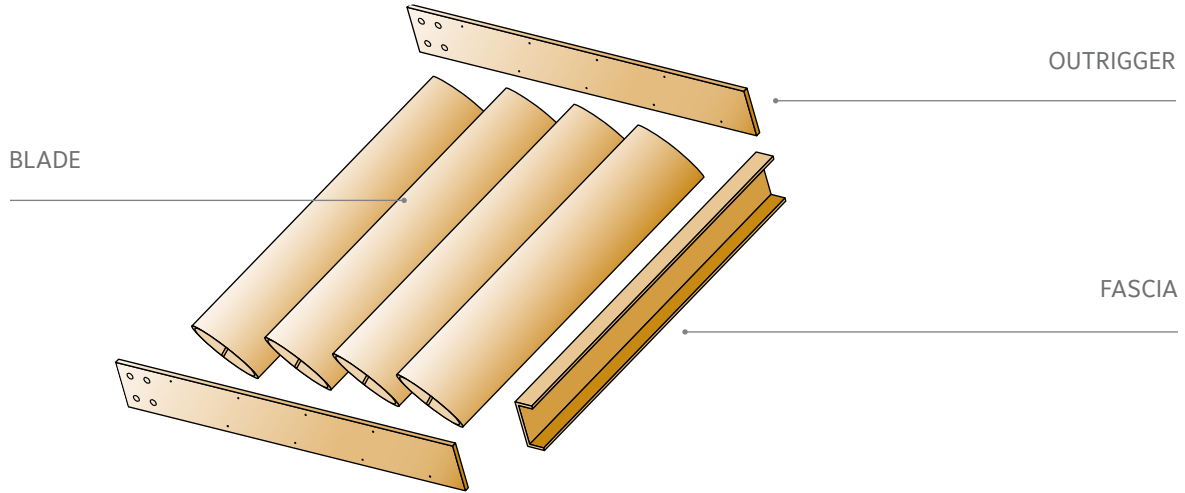

STEP 1 BLADE

Blades are the most crucial part of the sunshade. The blade profile determines shading, the spans between outriggers, and a large portion of the cost. Manipulating blade spacing and angle is the easiest way to dictate the effectiveness of the sunshade.

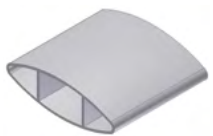

Airfoil Blade
4", 6", 8"



Rectangular Tube Blade
4", 6", 8", 10"



Z Blade
4" - 6"



The following table provides the maximum unsupported span for the Z Blade. Blade deflection is limited to $L/120$. When ship sections equal to or less than blade span only, outriggers are required. If blade span is less than the section width, false outriggers and fascia members are required.

Z Blade	Design Vertical Load (PSF)							
	30	40	50	60	70	80	90	100
4"	76	68	63	60	57	54	52	50
6"	81	74	68	65	61	58	56	54

STEP 2 FASCIA (FRONT, REAR, BOTH)



Rectangular Tube



Channel



Round Fascia



The fascia is the front and/or back edge of the sunshade. Front fascia designs can have a bigger effect on appearance than a blade design. When choosing a fascia profile, keep in mind the span has to be greater than or equal to the span of the blade chosen.

STEP 3 OUTRIGGER

Outriggers are the arms that extend out from the building. They provide the connection to the building, and therefore when choosing an outrigger type, loading should be factored into any calculations. The profile of the outrigger dictates how far they can cantilever from the wall. The thicker the outrigger, the greater weight it can support.



Rounded End Tapered



Channel



Rectangular Tube



Wedge



Rounded End



Flat Bar

STEP 4 FINISH TYPE

- ▶ Standard 2-coat 50 percent and 70 percent PVDF
- ▶ Pearledize 50 and Pearledize 70 (2-coat mica flake)
- ▶ Three-coat metallic or exotic finishes are available on special order
- ▶ Anodize finishes are available - for more information, consult *Ruskin*® about the correct application of each coating

HOW TO SHADE CORRECTLY

STEP 1

Find the Solar Altitude of the building during peak heating seasons (for example, January) and the Solar Altitudes during the heating and cooling swap seasons (for example, April/September).

Example: In Kansas City, the altitude on January 20th at noon is 30.75 degrees. The average altitude of April and September 20th at noon is 57.25 degrees.

SOLAR ALTITUDE the angular height of the sun measured from the horizon. When the sun is directly in the center of the sky, it has a solar altitude of 90 degrees.

STEP 2

Draw a section view of the wall and window.

STEP 3

Draw the altitude angle of the peak heating season starting at the top of the window. On our example this is a 30.75 degree line.

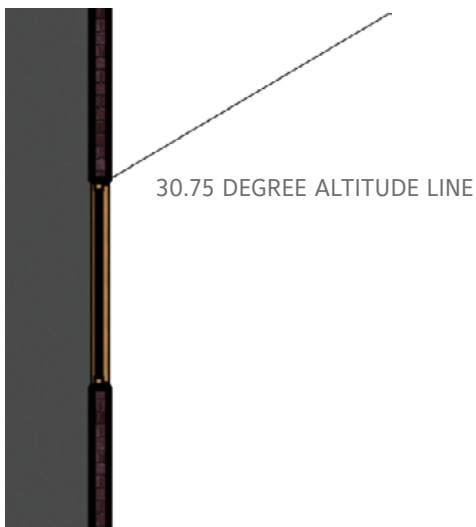

STEP 4

Draw the altitude angle of the heating and cooling swap seasons starting at the bottom of the window. On our example this is a 57.25 degree line.

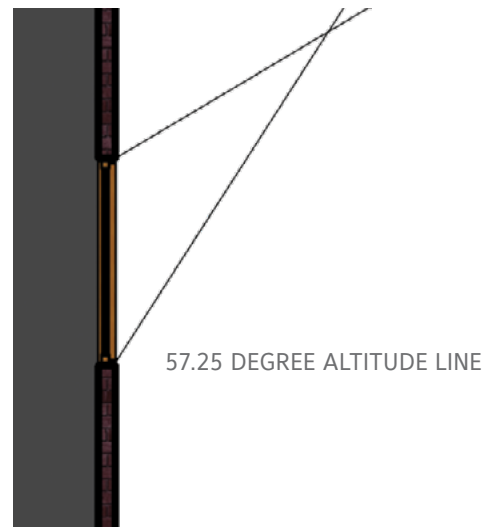

* This shading technique is best used for south elevations

STEP 5

The altitude lines will intersect. Draw a line from the intersection to the wall. This line represents the most effective projection dimension, as well as the location of the bottom of the sunshade. On our model, this dimension is 4'-1". This line also tells us where to mount the sunshade above the window. On this example, this dimension is 2'-5" above the top of the window.

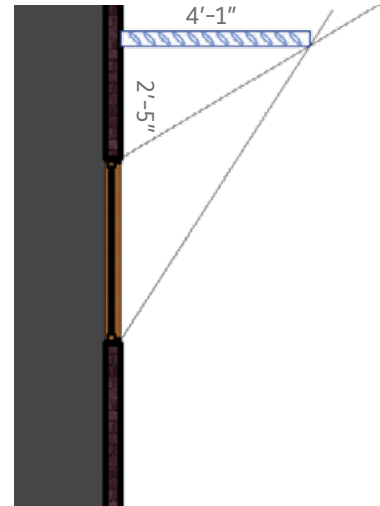

BENEFITS OF SHADING CORRECTLY

Sunshades diffuse or block sunlight, reducing the cooling energy a building uses. They eliminate the need for expensive tinted glass and associated maintenance costs. Each unit is custom-built for a unique exterior building design. Crucially, a reduction of direct sunlight and glare increases the comfort of living and work spaces.

Sunshades can be adapted to almost any structure in sunny, warm climates. They are particularly useful in housing projects, offices, and administration buildings.

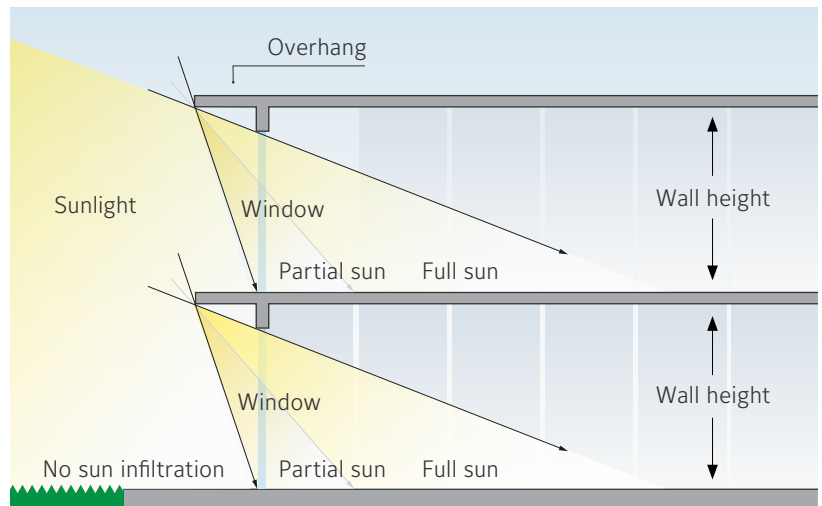

AIRFOIL BLADE TRELLIS

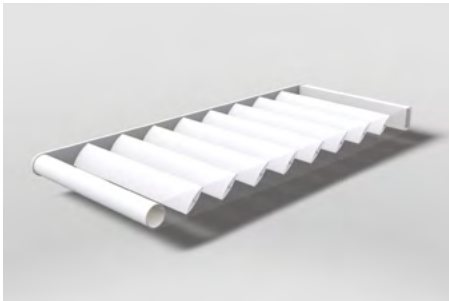

Saint Louis Science Center's 13,000 square foot exhibition hall addition was completed to provide better accommodations for traveling exhibitions and special events. Purely architectural in use, this project uses the *Ruskin*® sunshade to boldly enhance the appearance of the entire addition.



PROJECT
SAINT LOUIS
SCIENCE CENTER



LOCATION
SAINT LOUIS, MO



DESIGNER
PGAV DESTINATIONS

AIRFOIL BLADE



The renovation of Stephen F. Austin High School included uniquely mounted sunshades above the windows. It was designed to have an architectural wall bearing plate that connected to a bracket holding the sunshade outrigger. This design alleviated the contractor from connecting into the window mullion during the retrofit. This product contributed to earning the school a 3-Star Austin Energy Green Build program rating.



Star Austin Energy
Green Build Program Rating



PROJECT
STEPHEN F. AUSTIN
HIGH SCHOOL



LOCATION
AUSTIN, TX



DESIGNER
BLGY ARCHITECTURE

AIRFOIL BLADE



A simple and effective design shades windows along the entrance side to this free-standing medical building in San Antonio, TX. The finish is a 2-coat 70% PVDF that mimics a clear anodized coating. This finish type and color was chosen to avoid the difference in color that can occur with anodizing different aluminum alloys. Since the outriggers are aluminum plate, and the other components are extrusions, there is a risk of color variance with anodizing. The 2-coat sprayed and baked-on PVDF finish comes with a standard 20 year finish warranty, as well as the comfort of knowing there will be consistent color throughout the different aluminum alloys.



PROJECT

GEVIGA
MEDICAL CENTER



LOCATION

SAN ANTONIO, TX



DESIGNER

PHIL LLOYD SHOOP,
JR. AIA ARCHITECT

AIRFOIL BLADE



Hampton Roads Transit used Ruskin sun control devices as part of an 18-month renovation and new construction project for the bus maintenance and administration buildings. As part of the design process, the HRT maintenance building was planned and registered with the certification goal of LEED® Gold. The sunshades wrap around a 43,689 square foot administration building that finished the four-building project.



 **PROJECT**
HAMPTON ROADS TRANSIT
BUS MAINTENANCE AND
ADMINISTRATION BUILDING

 **LOCATION**
NORFOLK, VA

 **DESIGNER**
PARSONS BRINCKERHOFF

RECTANGULAR TUBE BLADE

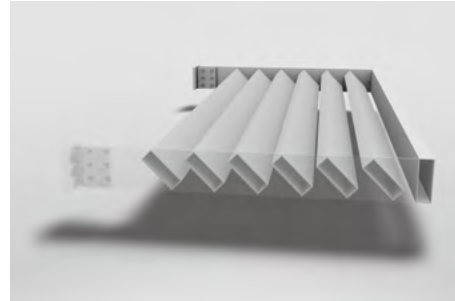

After Simonsdale Elementary School was approved to be rebuilt and expanded to include another local elementary school, the decision was made to incorporate sustainable designs that would save on long-term energy costs. Ruskin's sun control systems were installed over windows that were otherwise uncovered, providing protection from the sun on those elevations. Sustainable design changes helped to make the 81,165 square foot elementary school register with a LEED® Gold certification goal.



PROJECT
SIMONSDALE
ELEMENTARY SCHOOL



LOCATION
PORTSMOUTH, VA



DESIGNER
TYMOFF AND MOSS
ARCHITECTS

AIRFOIL BLADE

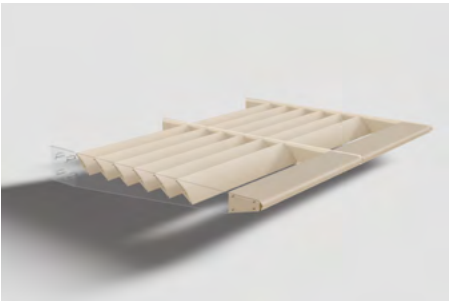

Built for the City of San Jose, the Educational Park Branch Library is an 18,057 square foot building that incorporates Ruskin's SSAFH6 design over the south elevation windows. The project goal was to achieve LEED® Silver certification, but the project exceeded those requirements and actually achieved LEED® Gold certification.



-  **PROJECT**
EDUCATIONAL PARK
BRANCH LIBRARY
-  **LOCATION**
SAN JOSE, CA
-  **DESIGNER**
ANDERSON BRULE
ARCHITECTS

RECTANGULAR TUBE BLADE



For its full renovation, Treanor Architects designed a trellis for the entrance of Emporia State University's Memorial Union. Using a Ruskin rectangular tube sunshade along with a unique tube outrigger, the trellis updates the eighth oldest student union entryway in the United States, and gives reprieve from precipitation to people walking underneath by having plexiglass placed over spider brackets at the top.



PROJECT
EMPORIA STATE
MEMORIAL UNION



LOCATION
EMPORIA, KS



DESIGNER
TREANOR ARCHITECTS

RECTANGULAR TUBE BLADE



As part of a multi-phase, 280,000 square foot addition and renovation project for Iowa State University, Ruskin custom tube sunshades were added to the Small Animal Hospital Facilities in Ames, IA. The goals for the university included having more access to natural light, and decreased annual operational costs across the campus. With the help of these custom sunshades, they were able to achieve this goal, as well as others due to major updates. The second phase of the total update and renovation is a LEED® registered project with the certification goal of LEED® Gold.



 **PROJECT**
IOWA STATE UNIVERSITY
SMALL ANIMAL
HOSPITAL FACILITY

 **LOCATION**
AMES, IA

 **DESIGNER**
INVISION ARCHITECTURE

BLADE SPAN/CANTILEVER DESIGN



INTERMEDIATE OUTRIGGERS

When do I use them?

If a blade is greater than the unsupported width then specify intermediate outriggers.

STRUCTURAL CALCULATIONS/ DELEGATED DESIGN SUBMITTALS

Ruskin® offers in-house calculations for your convenience.

Ruskin suggests you order stamped, structural calculations performed by a Professional Engineer corresponding to the state of the job site. Ruskin's in-house engineers have many years of experience calculating forces specifically applicable to sun control devices. These calculations will ensure that your sunshade will be supported, taking into account the following loads: wind, snow, live, and ice. An S1 drawing is required before calculations can begin.

Support **Outriggers** connect directly to the building

Intermediate Outriggers do not connect to building

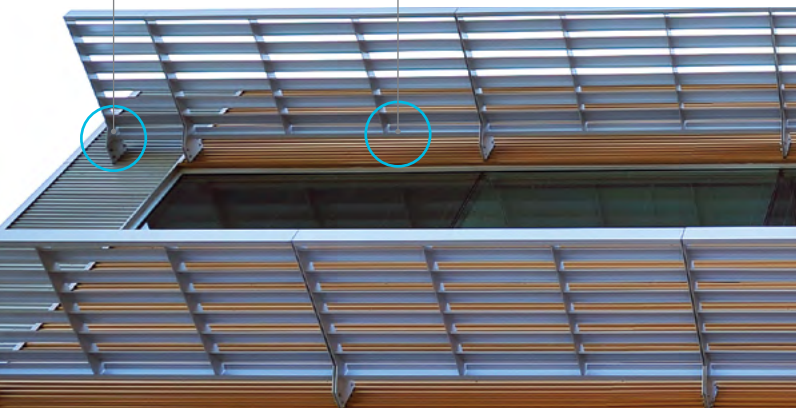

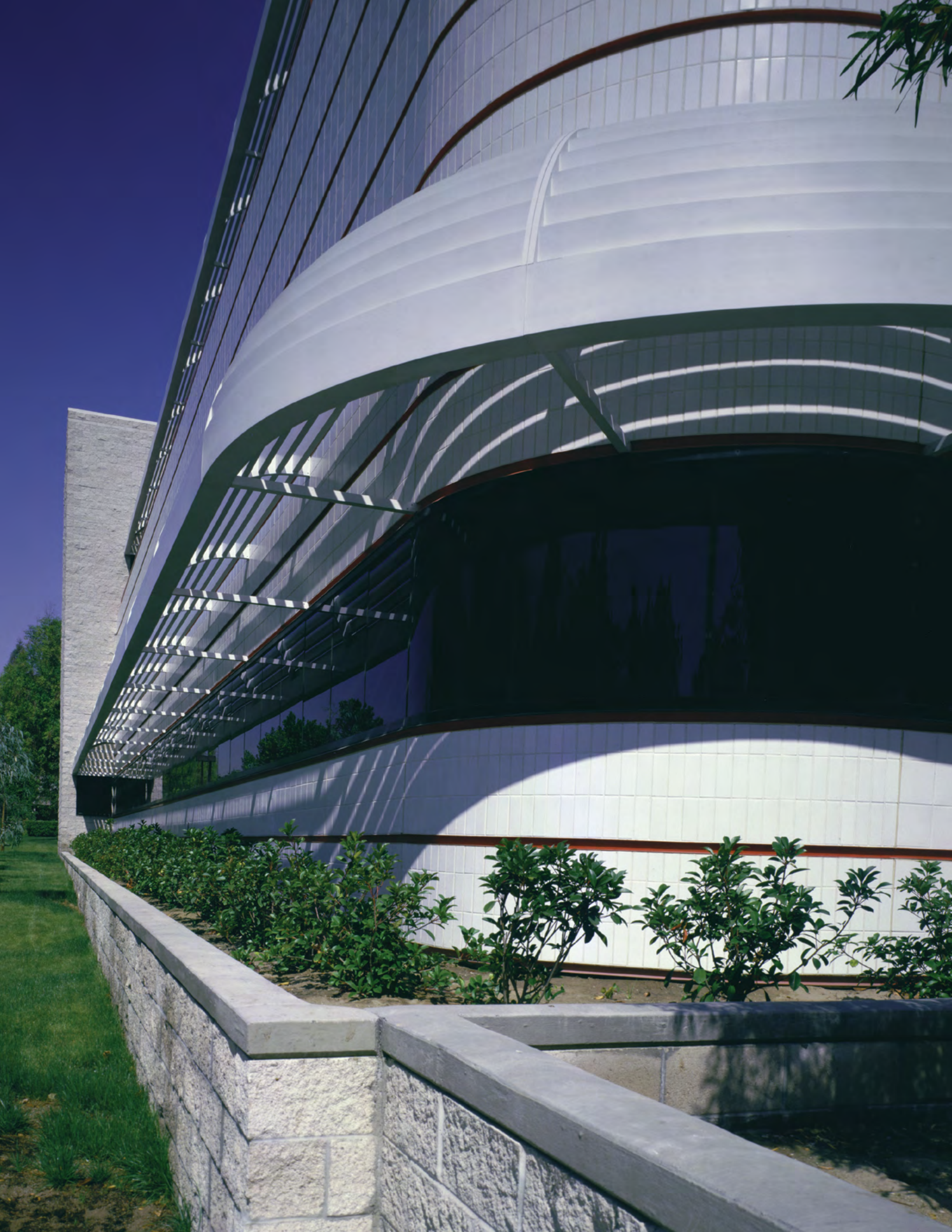

CURVED BLADES



CAN I INCORPORATE CURVED BLADES INTO MY SUNSHADE

Ruskin® can curve blades and fascias to match the curve of a building, however, the most economical design is to curve the front fascia piece, while segmenting straight blades (as shown in the photo). That will give the overall appearance of a curved sunshade without adding the cost to curve every blade.

WANT TO AVOID CURVED BLADES ALTOGETHER?

Eliminate curving costs altogether by segmenting the fascia and blades into smaller sections. The sunshade wraps around the building with ease, appearing to be curved from the outside.

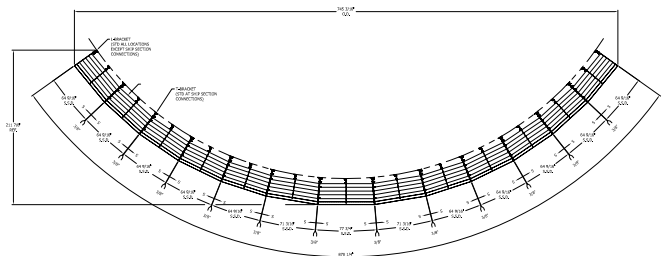
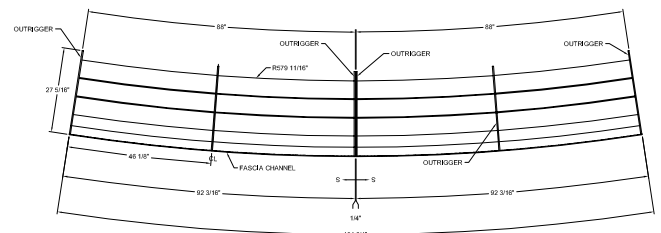

INSTALLATION BRACKETS

INCLUDE ALL ACCESSORIES FOR
YOUR *RUSKIN*® SUNSHADE



Bolted connection to steel



Bolted through concrete block



Concrete anchor connection

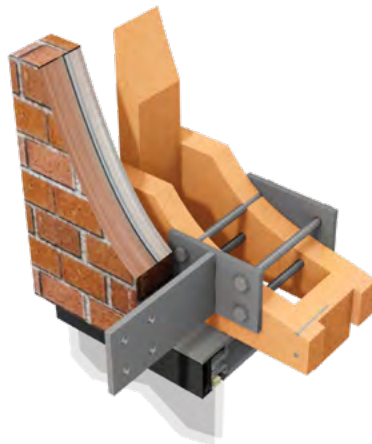

Bolted through wood connection



Curtain Wall Connection

Consult Ruskin for connection option details

MITERED CORNERS



MAKE YOUR CORNERS LOOK POLISHED

Sun Control products from *Ruskin*® wrap around the unique shape of your building. Ruskin's state-of-the-art miter saw makes any corner angle available. Ruskin can easily help design the connection at the corner.

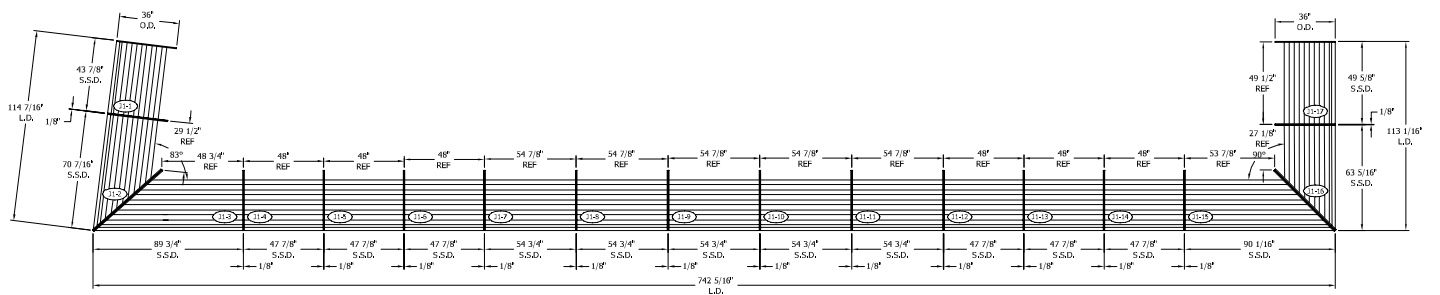
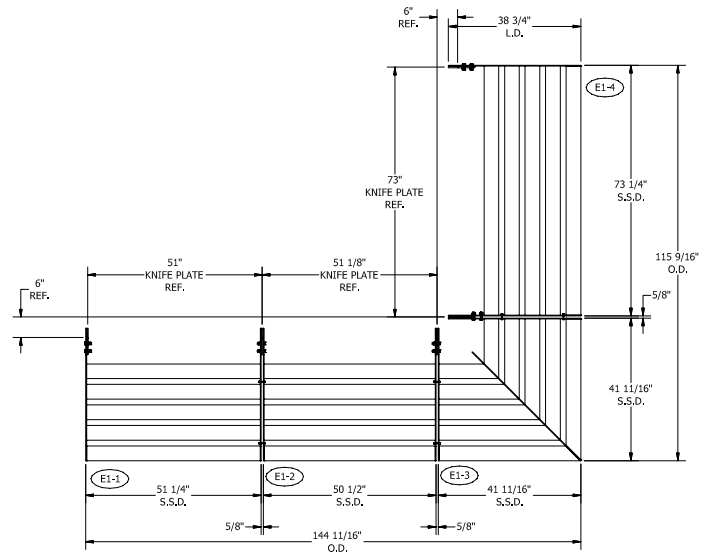

FOR LOUVERS AND SUNSHADES

IN-HOUSE PAINTED ARCHITECTURAL FINISHES

- ▶ 70 percent PVDF coatings meet or exceed American Architectural Manufacturers Association (AAMA) 2605 requirements
- ▶ 50 percent PVDF coatings meet or exceed AAMA 2604 requirements
- ▶ 50 percent and 70 percent Pearledize Finishes (Mica) to match clear and color anodize
- ▶ Numerous Standard Pearledize Colors available with optional custom color matches
- ▶ In-house Color Matching System
- ▶ Automated Finish System meets all ISO 14001 standards
- ▶ 10-year warranty on 50 percent PVDF and Pearledize 50
- ▶ 20-years warranty on 70 percent PVDF and Pearledize 70

IN-HOUSE ANODIZED ARCHITECTURAL FINISHES

- ▶ Meets or exceeds all AMCA 611 performance specifications
- ▶ 204-R1* Clear Coat
AAMA AA-C22A31 .04 mils minimum depth
- ▶ 215-R1** Clear Coat
AAMA AA-C22A41 .07 mils minimum depth
- ▶ Color Anodize AAMA AA-C22A44** is available for louvers or sunshades***

* 3 year warranty

** 5 year warranty

*** 70% PVDF Finishes are recommended for Sunshade Systems to ensure durable and consistent finish for varying component alloys.

SPECIFICATIONS

WHERE CAN I FIND SPECIFICATIONS FOR RUSKIN'S SUN CONTROL PRODUCTS?

If you need a quick specification, *Ruskin*® has a three-part Construction Specification Institute (CSI) set of specifications ready for use located in our online product catalog.

If you want a custom specification, Ruskin has a new Sun Control preview tool with a specification writer built-in. Visit www.ruskin.com/category/481-Sun-Control-Sunshades to get a glance at the sunshade with your chosen components and write a specification by clicking the **Download Spec** button.

Ruskin® Sun Control products provide optimal shading to promote lower energy costs and to cut down the glare on your buildings. These sun control solutions create comfortable environments and increase lifespans of mechanical equipment, resulting in higher productivity and sustainability.

