



# PANORAMA

- Busbar Energy Distribution Systems / • Support Systems / • Cable Tray Systems /
- Trolley Busbar Systems / • Fit-Out Solution

# EAE GROUP IN NUMBERS



## Since 1973

EAE Group of Companies started its journey in the electrical sector in 1973 with the establishment of EAE Elektrik. Since its founding, EAE has grown rapidly, expanding its production and areas of operation by incorporating EAE Lighting in 1983, EAE Machinery in 1996, EAE Electrotechnics in 2004, and EAE Technology in 2009.

EAE carries out its production activities in accordance with ISO 9001 Quality Management, ISO 14001 Environmental Management, ISO 14064-1 Greenhouse Gas Management System, ISO 45001 Occupational Health and Safety Management, ISO 10002 Customer Satisfaction Management, ISO 50001 Energy Management System, and ISO 27001 Information Security Management System standards.



**50+**  
Years Experience



**8**  
Active Factories



**370.000m<sup>2</sup>**  
Enclosed Space



**3**  
R&D Centers



**150+**  
Countries Exported To

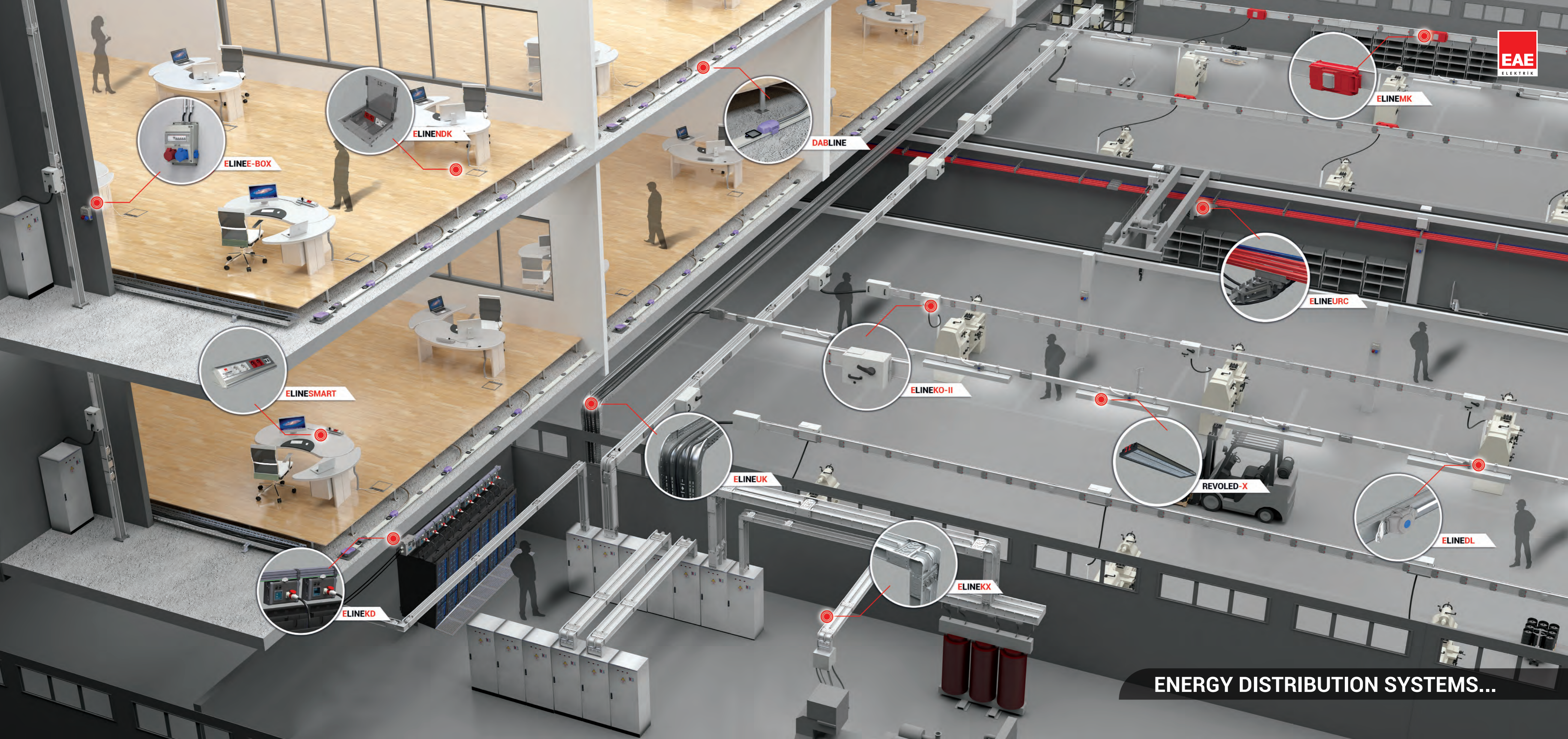

ELINEE-BOX

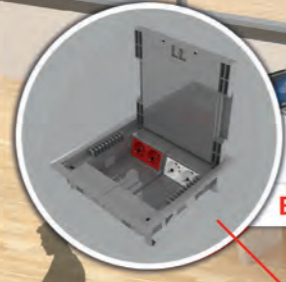

ELINENDK



DABLINE



ELINEMK

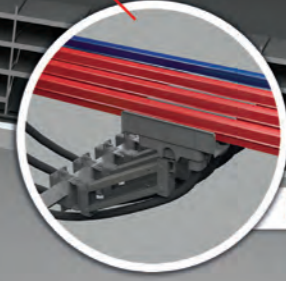

ELINEURC

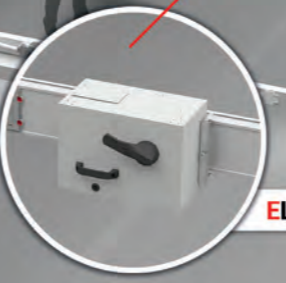

ELINEKO-II



ELINEUK



REVOLVED-X



ELINEDL

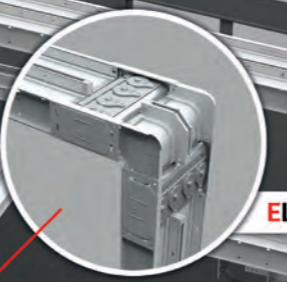

ELINEKX



ELINESMART

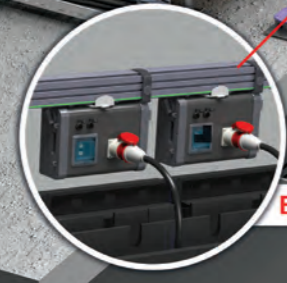

ELINEKD

ENERGY DISTRIBUTION SYSTEMS...

# BUSBAR ENERGY DISTRIBUTION SYSTEMS

## E-LINE KX

Compact Busbar Distribution Systems 400A...6300A

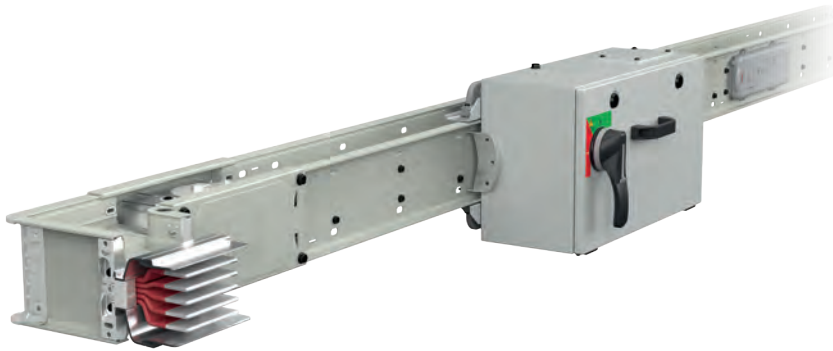

### Overview

The EAE E-Line KX Series compact busbar system is designed for use in projects requiring high power distribution, and is rated from 400A to 6300A using the latest technology.

### Features

- Modular structure
- Ability to supply energy either from the joints or from the tap-off points (Bolt-on or Plug-in)
- High electrical and mechanical strength
- The compact structure offers many benefits in the installation.
- Fast, easy and reliable installation with single bolt joint construction.
- Output units allow a significant saving about panel and system cost.
- Special design for minimal voltage drop
- Tin plated aluminium or copper conductors
- IP55 protection degree
- Aluminium housing
- Epoxy insulation
- Fire resistance as per IEC 60331

### Applications

- Production areas in factories
- Textile factories
- Furniture factories
- Automotive and automotive sub-industries
- Malls
- Exhibition areas
- High rise buildings
- Hotels
- Hospitals
- Business centres

### Advantages of E-Line KX Compact Busbar

- High short circuit resistance due to compact construction
- Less voltage drop in comparison to cable systems
- Special alloy metal enclosure provides higher mechanical strength and causes less electromagnetic interference
- Better cooling capability
- High resistance to fire
- Seismic resistance
- Protection Degree (IP55 standard and IP67 optional)
- Requires less space in comparison to cable systems



# BUSBAR ENERGY DISTRIBUTION SYSTEMS

## E-LINE CCR

Compact Busbar Distribution Systems 600A...6300A



### Overview

The body of the E-Line CCR busbar is formed using DURACOMP, a composite material of epoxy resin and pure silicon with Aluminium housing body which gives protection against arduous environments and high impact.

### Features

- CCRC Current ranges for Copper conductor series; 650A / 850A / 1000A / 1250A / 1600A / 2000A / 2500A / 3200A / 3400A / 4000A / 4500A / 5000A / 5750A / 6300A
- CCRA Current ranges for Aluminum conductor series; 600A / 800A / 1000 / 1250A / 1600A / 2000A / 2500A / 3000A / 3300A / 3600A / 4000A / 4500A / 5000A / 5400A
- IP68 protection degree
- 3, 4, 4,5 and 5 conductor options
- Clean earth option

### Applications

- Outdoor Environments
- Oil and gas plants
- Nuclear plants
- Cement plants
- Power plants
- Harbours and shipyards
- Food processing plants
- Tunnels and underpasses

### Fire and Earthquake Resistance

IEC 60331-1, 3 hours of continuous current under fire condition  
2 hours current continuity according to BS 8602 standard  
Seismic Resistance as per IEC 60068-3-3 / 60068-2-57 and IEEE 693



II 2G Ex mb IIC Gb  
II 2D IIIC Db

### EX - Protected

ATEX according to EN 60079-0:2009, EN 60079-18:2009, EN60079-31:2009

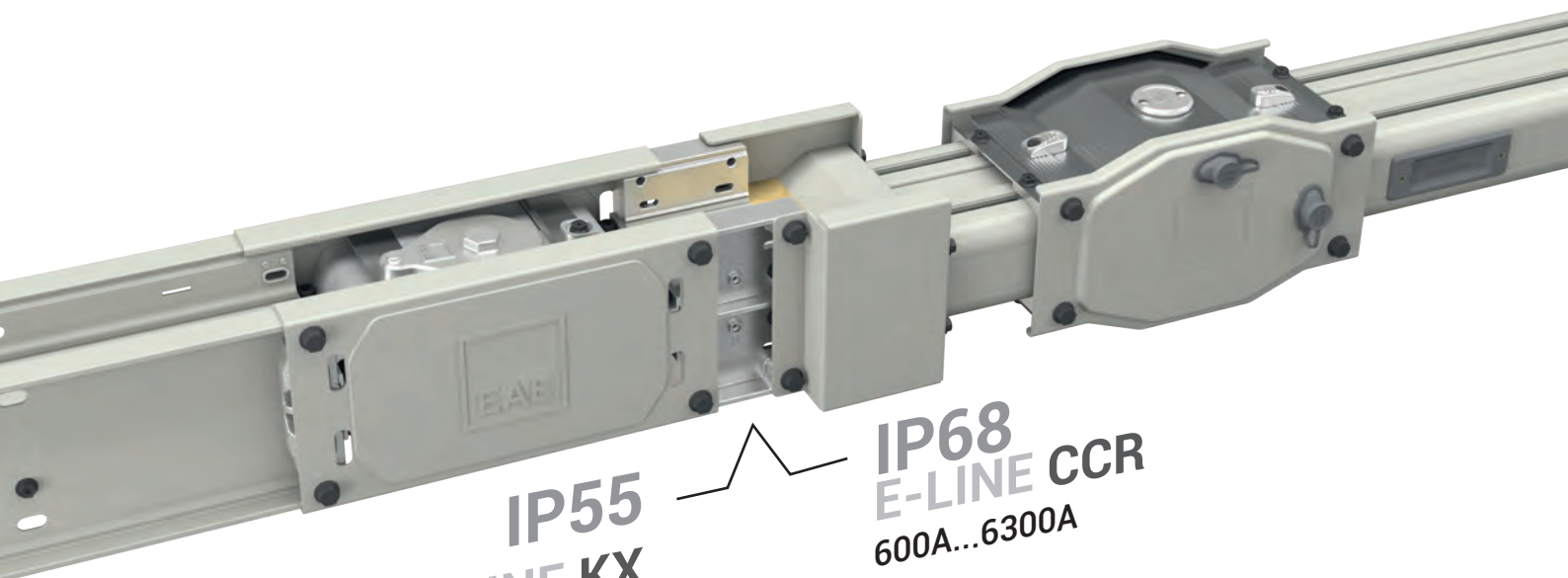

**IP55**  
**E-LINE KX**  
400A...6300A

**IP68**  
**E-LINE CCR**  
600A...6300A

### E-LINE CCR-KX

CCR-KX transition module offers the possibility of reducing time and cost with direct installation.

# BUSBAR ENERGY DISTRIBUTION SYSTEMS

## E-LINE CR

Compact Busbar Distribution Systems 630A...6300A

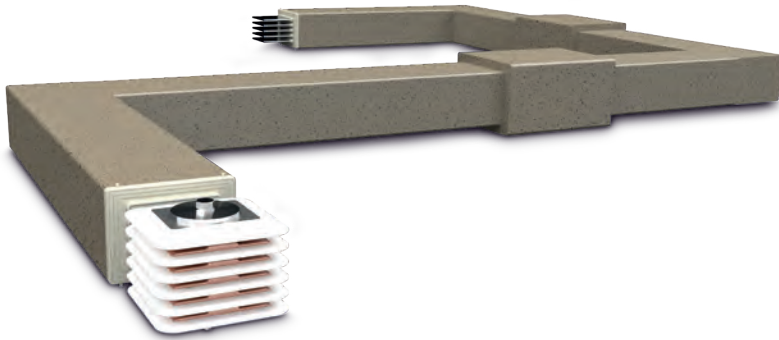

### Overview

The body of the E-Line CR busbar is formed using DURACOMP, a composite material of epoxy resin and pure silicon which gives protection against arduous environments and high impact.

### Features

- Current ranges for CRA Aluminium conductor series; 630A / 800A / 1000A / 1250A / 1600A / 2000A / 2250 A / 2500A / 3000A / 3200A / 3600A / 4000A / 5000A
- Current ranges for CRC Copper conductor series; 800A / 1000A / 1250A / 1600A / 2000A / 2500A / 3000A / 3200A / 3600A / 4000A / 5000A / 6300A
- IP68 protection degree
- 3, 4, 5 and 6 conductor options
- Clean earth option

### Fire and Earthquake Resistance

IEC 60331-1, 3 hours of continuous current under fire condition

Seismic Resistance as per IEC 60068-3-3 / 60068-2-57 and IEEE 693

### EX - Protected

ATEX according to EN 60079-0:2009, EN 60079-18:2009, EN60079-31:2009

### Applications

- Links between transformers and switchboards
- Oil and gas plants
- Nuclear plants
- Cement plants
- Power plants
- Harbours and shipyards
- Food processing plants
- Tunnels and underpasses

### DIN 4102-12

System Integrity Under Fire

E60 = Standard

E120 = External Protection Support

## E-LINE MV

Medium Voltage Busbar Distribution Systems 950A...5000A

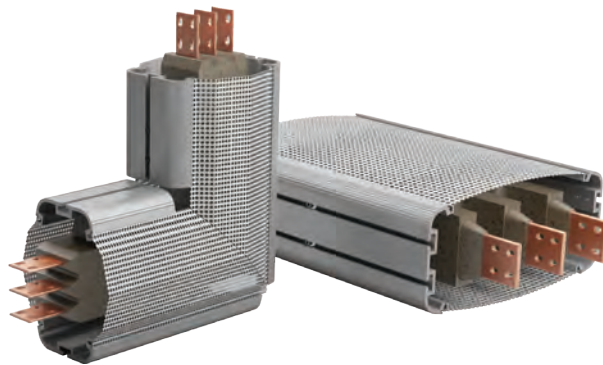

### Overview

The E-Line MV Series Busbar Systems, as the newest addition to the busbar product range, is offered with 12 kV and 17,5 kV variants. It offers safe and efficient power transmission. MV CR is manufactured in a single body with Cu conductors embedded in DURACOMP insulation which is a composite material of epoxy and pure silicon.

### Features

- 12 kV and 17,5 kV variants
- DURACOMP composite body
- Ex-proof
- IP68 protection degree

### Applications

- Outdoors
- Industrial buildings
- Petrochemical Industry
- Areas with flood risk
- Oil and natural gas Industry
- Power Generation Industry
- Data centers

# BUSBAR ENERGY DISTRIBUTION SYSTEMS

## E-LINE KL

Busbar Distribution Systems 160A...1250A



### Features

- Modular structure
- Plug-in tap off outlets at every 25cm
- Aluminium or copper conductors
- 4 or 5 conductors
- Tin plated conductors
- Dust cover on outlet points
- IP55 protection class

### Overview

The "E-Line KL Series" medium-range busbar systems are used in medium-sized buildings or industrial facilities, providing suitable solutions for electrical transmission and distribution in horizontal or vertical applications.

They offer significant cost savings by using fuse-switch disconnectors/MCCBs (Molded Case Circuit Breakers) with metal boxes or plastic boxes compatible with MCB (Miniature Circuit Breaker) switches for smaller currents, according to specific needs.

### Applications

- Production areas in factories
- Textile plants
- Furniture plants
- Automotive plants
- Automotive sub-industry
- Shopping centres
- Exhibition centres
- High-rise buildings
- Hotels
- Hospitals
- Business centres
- Data centres

## E-LINE KO-II

Busbar Distribution Systems 160A...800A

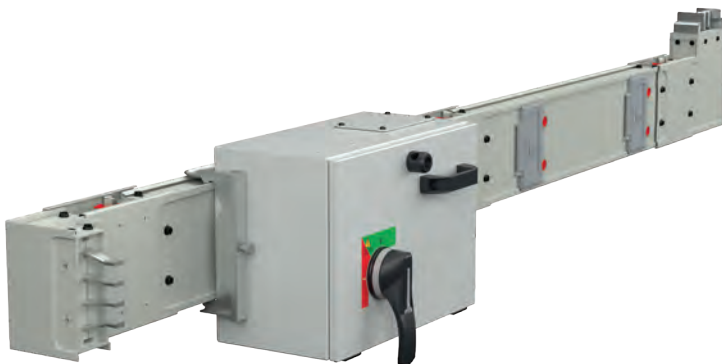

### Features

- Modular structure
- Plug-in tap off outlets at every 25cm
- Aluminium or copper conductors
- 4, 4,5 or 5 conductors
- Tin plated conductors
- Dust cover on outlet points
- IP55 protection class

### Overview

"E-Line KO Series" medium range busbar systems provide suitable solutions for electricity transmission and distribution in medium-sized buildings or industrial facilities. They can be used in horizontal or vertical applications. Tap off box solutions comprise sheet metal boxes with circuit breakers, or plastic boxes for small currents which are compatible with Miniature Circuit Breakers.

### Applications

- Production areas in factories
- Textile plants
- Furniture plants
- Automotive plants
- Automotive sub-industry
- Shopping centres
- Exhibition centres
- High-rise buildings
- Hotels
- Hospitals
- Business centres
- Data centres

# BUSBAR ENERGY DISTRIBUTION SYSTEMS

## E-LINE KD

Data Rack Busbar Systems 160A...1000A



### Overview

To power the mission critical IT infrastructures, EAE offers a highly flexible Busbar Systems for reliable and energy efficient operations in your Healthcare System's Data Centers.

### Features

- Plug-n-play anywhere along the bar
- Protected Tap-Off Contacts
- Tap-Off contacts with heat cycle testing
- Al and Cu conductor options
- Safe Alignment mechanism ensures correct installation and operation
- Special interlock mechanism enabling to carry the weight of the plug-in box and cables by the busbar housing
- Up to 6 conductor option
- IP23D protection

### Applications

- Data Center
- White space general usage
- White space points which requires high density usage of tap-off boxes

## E-LINE MK

Busbar Distribution Systems 100-160-225-250A



### Overview

The small power range busbar systems of "E-Line MK Series" provide flexible and cost-effective solutions for the transmission and distribution of electricity in small-sized enterprises, workshops and industrial facilities.

### Features

- Modular structure
- Plug-in tap off outlets at every 25cm on both side
- Tin plated aluminium or copper conductors
- 4 or 5 conductors
- Hinged and lockable dust cover on outlet points
- Installation without using a torque wrench (shearhead bolts)
- IP55 protection class
- Flexible elbows and expansion modules

### Applications

- Small enterprises
- Local production areas in factories
- Workshops
- Textile plants
- Automotive plants
- Automotive sub-industries
- Small-sized industrial plants
- Shopping centres
- Large markets
- Data centres

# BUSBAR ENERGY DISTRIBUTION SYSTEMS

## E-LINE KY-S

Lighting & Low Power Distribution Systems 25-40-63A



### Overview

KY-S Busbar System is suitable for all kinds of lighting, sockets and low power circuits with 25-40-63A current levels. Also within the scope of lighting automation, DALI and DIM circuits can be used to transmit the emergency lighting kit reference voltage.

### Features

- 3 and 4m standard busbar length, plug-in points every 1m,
- At all joint and plug-in points, the contacts are plated with silver,
- Copper conductors are covered with full length tin and copper oxide formation is prevented,
- Simple joint structure that prevents deflection and stretching.

### Applications

- Offices
- Business centers
- Banks
- Schools
- Conference centers
- Car Park

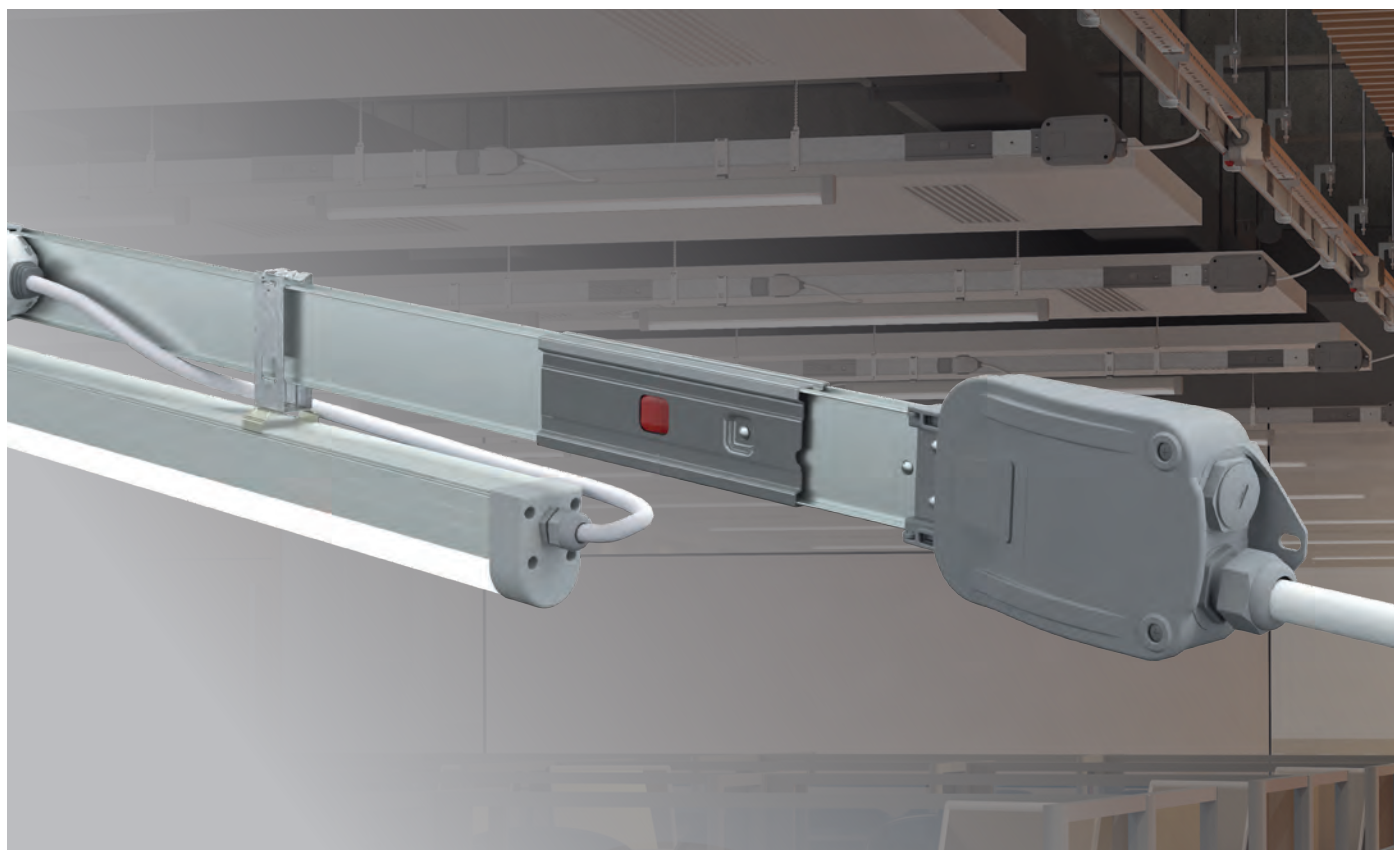

# BUSBAR ENERGY DISTRIBUTION SYSTEMS

## E-LINE DL/SL

Multi-conductor Lighting Busbar Systems 25-32-40A

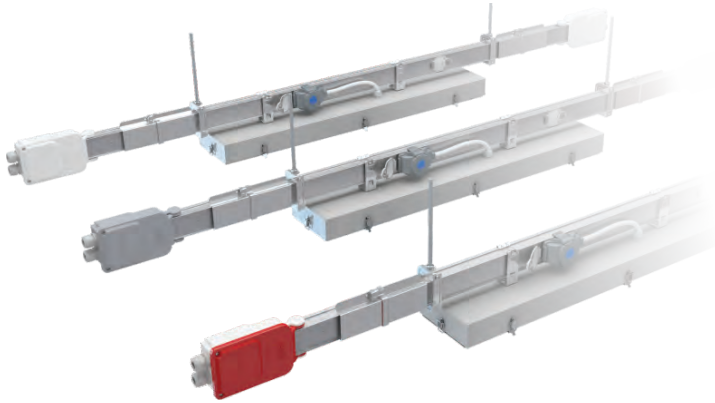

### Features

- Choice of conductor configurations up to 10 conductors with 5+5 form
- Fast, easy and reliable installation
- Tap-off plugs are available in different colours to indicate the phases
- Strong body structure which can support all types of luminaires
- Double-sided 8 output points on busbar (DL)
- IP 55 protection class
- Clean Earth "CE" conductor for UPS circuit
- SL Busbar offers an affordable solution with the option to draw current from a total of 4 tap off points per 3m length.
- The Emergency Kit (ACK) supply and the Dali signal are fed through the same busbar and tap off plug negating the need for extra cabling.

### Overview

The E-Line DL range of busbar systems are used in buildings on lighting and socket circuits where 25A, 32A or 40A Three-phase or Single-phase power is required. 10-16A plugs or 25A tap-off boxes with a cartridge fuse or miniature circuit breaker are specially designed to supply lighting and power circuits as per the specifications.

### Applications

- Offices
- Business centres
- Banks
- Schools
- Congress halls

## E-LINE KAP

Plug-in Busbar Distribution Systems 40A-63A



### Features

- Conductors are electrolytic copper tin plated and insulated along their full length with a self-extinguishing plastic sleeve. (formation of copper oxide is inhibited)
- Fast, easy and reliable installation
- Standard 4 or 5 conductor.
- Tap-off plugs are available in different colours to indicate the phases
- Plugs and tap-off boxes are designed with different contact sequences to avoid interchangeability problems
- The joint contacts are silver plated and highly oversized in comparison with the nominal current to withstand in total safety possible short term current peaks
- One plug-in output point at standard 75cm intervals
- Manufactured in accordance with IEC 61439-6 standard. It has DEKRA and TSE certifications
- Offering output from from tap off plugs or boxes with 16A and 32A cylinder fuse or miniature circuit breaker (MCB) and connectors

### Overview

The E-Line KAP small power busbar range offers extremely economical solutions for the distribution of power in small enterprises and confection plants. The KAP range is ideally suited to supply low power machinery such as sewing machines, hand tools and machine tools.

### Applications

- Production and storage areas in factories
- Workshops
- Confection plants
- Parking areas
- Raised floors in offices
- Logistics warehouses
- Large markets
- Malls

# SUPPORT SYSTEMS

## E-LINE A-A

### Support - Accessories Systems

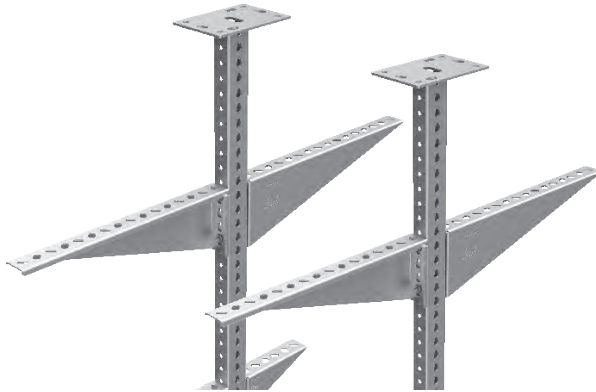

#### Overview

E-LINE A-A series and E-Line Seismic suspension systems are used in buildings and factories; in concrete or steel structures to carry Busbar, Conduit, Cable Ladder, etc. Systems appropriately. Service and light service-type suspension types diversities are available according to the weight of the system to be carried.

#### Features

- Certified seismic suspension range
- Light service-type and heavy service-type suspension types
- Produced with a wall thickness of 2mm to 6mm. (Only AT3 and KT types are produced with 1.5mm thickness)
- Pre-galvanized and hot-dip alternatives
- Hot-dip production in all welded supports
- Load deflection graphs where carrying capacities of all supports are shown
- Plating which is durable against 400 hour salt test to avoid corrosion of consumable connection elements such as rod, bolt, nut, etc.
- Customized support production
- Supports with fire resistance certificate (E30, E60, E90)

## MFIX

### Electro-Mechanical Support and Suspension Systems



#### Overview

MFIX offer the most convenient and professional solutions for mechanical installation suspension project by their high quality and practicability. While ensuring fast and easy assembly features through their modular structure, also prevent formation of applications that might yield adverse outcomes. Our products are ensured to have long service life by being exposed to hot-dipping process. Suspension parts can be coated by special coating methods in accordance with customer requirements.

#### Features

- Pre-galvanized and Hot-Dipping alternatives
- Suspension system varieties of Light, Medium and Heavy-Duty type
- Coating resistant to salt test of 400 hours for the purpose of corrosion prevention of products such as Stem Bar, Bolt and Nuts of switch material fittings
- Mechanical suspension solutions specific to customer requirements.
- Design programs and expert engineering support is available specific to electromechanical suspension systems.

#### Applications

- High-rise buildings
- Hotels, shopping malls
- Industrial buildings
- Hospitals
- Petro-chemical plants
- Subways, tunnels

# SUPPORT SYSTEMS

## E-LINE BINRAK

### E-LINE Binrak (G Profile) Tray Series

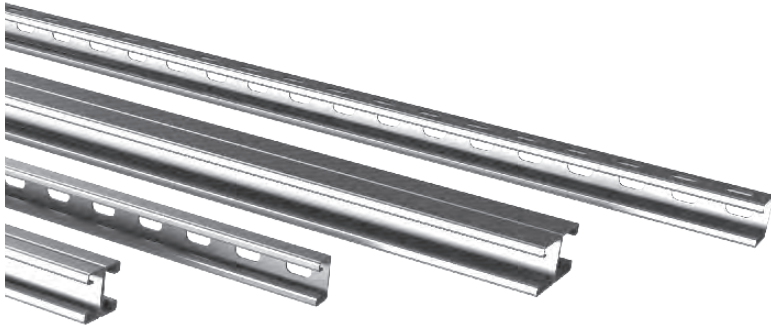

#### Overview

E-LINE Binrak Trays Series are produced Pregalvanized in Standard heavy service type in TSE and ISO 10143 standard, hot-dip in TS EN ISO 1461 standard and with 3m length with Stainless steel (304, 304L, 316, 316L) as standard. It is designed to carry the support systems in facilities and buildings as well as mechanical, electrical and industrial products.

#### Features

- In Heavy Service Type
- In 41x21 mm and 41x41mm sizes as standard
- Standard t = 1,5/2/2,5 thicknesses are produced.
- In 1.5/2/2,5 thicknesses
- Welding different surfaces of Binraks to each other to create stronger structures and brackets
- Large range of connection accessories and connection parts with
- 6 mm thickness (Production of standard connection accessories in special dimensions)

- Quick assembly convenience from each point on railed surface
- Possibility of using with suspension systems in mechanical, electrical and industrial areas
- Quick assembly with conduits, cable ladders, pipe supporting systems without requiring welding or boring thanks to its perforated structure
- Standard productions in hot-dip and then special protective plating on hot-dip special to EAE in TS EN ISO 1461 standard; galvanized option complying with TS EN 10143 standards (pre-galvanized) and Stainless steel (304, 304L, 316, 316L)

## E-LINE RSP

### Industrial Rectangular Profile Systems

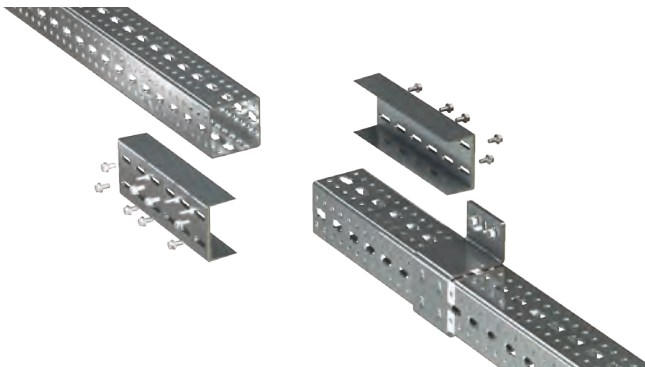

#### Overview

E-Line RSP Rectangular Profile System is a specially designed solution to meet your industrial connection needs. With the unique advantages of the tapered threaded bolts used in this system, it offers significant gains in terms of labor, cost, and performance.

#### Features

- Provides a 4-fold time advantage in assembly speed compared to traditional manufacturing
- Allows for creative and flexible applications due to its modular structure and accessories
- The use of intelligent bolts at connection points eliminates the need for nuts and washers
- Does not require welding and painting, offering material and labor advantages.
- Provides high-capacity solutions for long span openings and heavy-load conditions
- Optional Hot-Dip Galvanizing and Stainless Steel material choices are available for corrosive environments

#### Applications

- High-rise buildings
- Hotels, shopping malls
- Industrial buildings
- Hospitals
- Petro-chemical plants
- Data center
- Subways, tunnels

# SUPPORT SYSTEMS

## E-LINE SEISMIC

### Seismic Bracing Systems



#### Overview

EAE Seismic suspension systems offer rigid solutions for earthquake protection for busbar trunking, cabling and other building services installations that are designed for steel supports and spaceframe connections offer fast and easy mounting.

#### Faster

Up to 50% mounting cost savings and fast installation compared to non-rigid systems.

#### Maximum Application

Since connection from one location is sufficient, maximum compatibility with existing installations.

#### Can be Installed at a Later Time

It can be installed in active facilities on the current cabling system without any dismantling.

#### Seismic Support Systems Product and Service Groups

- E-Line Seismic supports
- E-Line Seismic rod reinforcements
- E-Line steel beam supports
- E-Line pipe beam supports
- E-Line seismic technical supports

#### Solutions

- Busbar, cable trays, cable pipe installations seismic protection systems
- Mechanical and hygienic installations seismic protection systems
- Ventilation ducts seismic protection systems
- Suspended equipment seismic protection systems

## E-LINE SOLAR MOUNTING SYSTEMS

### PV Module Support Systems

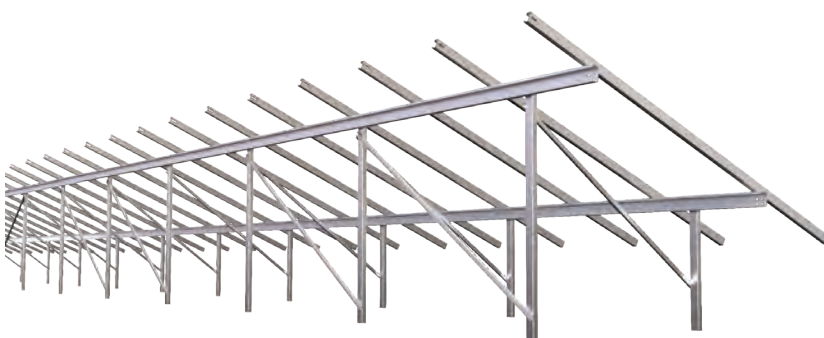

#### Overview

E-Line Solar Mounting Systems offers reliable and fast assembly on site and roof applications with its high quality, project-specific design, patented and special assembly system. EAE reflects its manufacturing, design and market experience of 50 years and manufacturing and service policy without compromising from quality to Solar Power sector applications. The corporation therefore has the capability of performing project-specific design and manufacturing for domestic and overseas projects to accomplish and adopt new technologies in renewable energy.

#### Features

- Ability to perform the entire process in a single plant
- Tested and approved model frameworks
- Project based flexible special design and manufacturing facilities
- Expedited and quality manufacturing
- Domestic Goods Certificate for all products

# CABLE TRAY SYSTEMS

## E-LINE UKE

### Cable Tray Systems

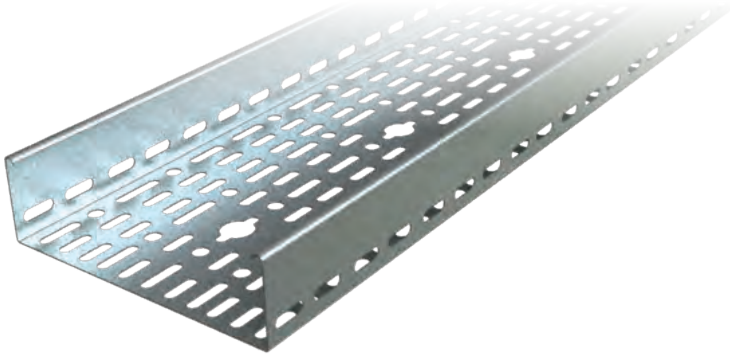

#### Features

- Heavy duty type
- Standard 40/50/60/75/100mm heights produced
- 50/100/150/200/250/300/400/500/600mm widths
- 0,8/1/1,2/1,5/2mm thickness
- 3000/4000/5000/6000mm lengths
- According to the TS EN 10346 and TS EN 10143 standards galvanized option (pregalvanized)
- Possibility to connect the various accessories that 20,5 diametres hole in the middle of the tray
- Wide range of accessories
- Fire resistance certificates (E30-E60-E90)
- Galvanized steel painted finish available on request (epoxy, epoxy polyester, polyester)

#### Overview

The E-Line UKE series pre-galvanized cable trays are produced in a standard heavy-duty type according to TSE (Turkish Standards Institution), TS EN 10346, and ISO 10143 standards. Manufactured through the "Roll Forming" method, they are produced as a single piece up to a length of 6m. The standard length is 3m. They are designed to carry cable installations in internal environments within facilities and buildings.

#### Applications

- Warehouses
- Workshops
- Car parking areas
- Markets
- Business centres
- Industrial plants
- Similar work places and spaces

## E-LINE UKFG

### Cable Tray Systems

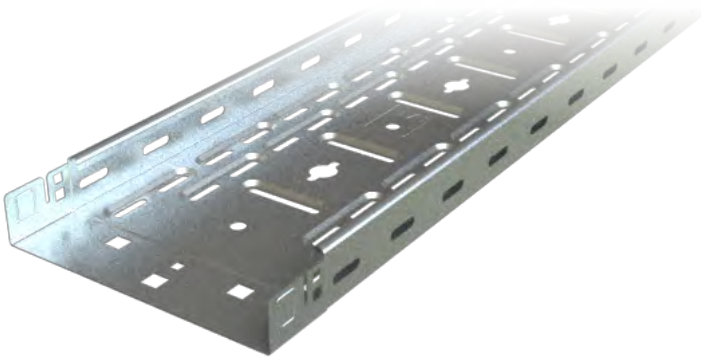

#### Features

- Heavy duty type
- 40/50/60/75/100mm heights
- 100/200/300/400/500/600mm widths
- 100/200/300mm widths 0,7mm and 400/500/600mm widths 0,9mm thicknesses
- Thanks to special forming of the edges of the tray lengths, it can bear the load equal to the products with standard thickness
- Thanks to its snap on system, easily mounted without the need for additional elements
- Wide range of accessories
- Fire resistance certificates (E30-E60-E90)

#### Overview

E-LINE UKFG systems can be connected with a bolt without the need for any an additional equipment thanks to its snap on system on the edges. It offers the greatest savings with minimum installation time thanks to its minimum thickness and minimum costs and simple installation on site.

#### Applications

- Parking areas
- Hotels, housing
- Factory and industrial plants
- Food processing plants

# CABLE TRAY SYSTEMS

## E-LINE KM

### Pre-galvanized Foldable Cable Ladders



#### Features

- Heavy duty type
- 40/50/60/75/100/125/150mm heights
- 100/200/300/400/500/600 widths (700-800-900-1000 special widths on request)
- 3000mm length (6000mm special length on request)
- TS EN ISO 1461 standard hot-dip and TS EN 10346, TS EN 10143 standart pre-galvanized production.
- Load carrying capacity can be increased by giving shape to the sheet iron.
- Products can be used along the side walls in horizontal suspended application. Thereby provides a significant cost advantage.
- 300mm equally spaced traverse structure
- More cable space than traditional ladders with special traverse height
- Fire resistance certificates (E30-E60-E90)

#### Overview

E-Line KM pre-galvanized foldable cable ladders are featured with one-way folding. Thanks to this, they take up much less space than the E-Line KC series cable ladders. This reduces shipment and storage costs.

#### Applications

- Suitable for internal and external environment
- Industrial plants
- Skyscrapers
- Textile and confection plants
- Automotive plants
- Shopping centres
- Hospitals
- Conference centres
- Parking areas
- Oil & Gas plants
- Tunnels; rail systems, bridges, underpasses

## E-LINE TKS

### Pre-galvanized and Hot-dip Trunking Systems



#### Features

- Heavy duty covers and locked non perforated structure
- 3 locking points every 3m
- Possibility of the quick lock cover
- H:50-75-100-150 and 200mm heights
- 50/75/100/150/200/300mm widths
- 1mm, 1,2mm and 1,5mm thickness
- Providing resistance to the passage of the grounding continuity reducer coupling (which is important for data and telephone cables)
- 3000mm lenghts
- TS EN ISO 1461 standard hot-dip and TS EN 10346, TS EN 10143 standart pre-galvanized production
- Wide range of accessories

#### Overview

E-Line TKS series trunking cover cable trays systems are used for cabling in indoor environments. They are manufactured as pre-galvanized or Hot dip. The cover is easily mounted thanks to the special lock system. Mounting the modules on trays is quick and simple.

#### Applications

- Acceptable internal environment
- Connection between machines
- Banks (IT centres)
- Required mechanical and UV protection areas

# CABLE TRAY SYSTEMS

## E-LINE KME

### Hot-dip Galvanized Cable Ladders

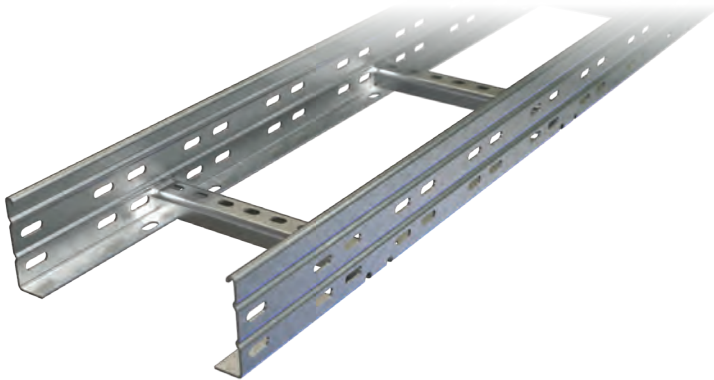

#### Features

- Heavy duty type
- 40/50/60/75/100/125/150mm heights
- 50/100/150/200/250/300/400/500/600mm widths
- With Binrak traverse with 700/800/900 width options, high bearing capacity (KME)
- 1,2/1,5/2mm thickness
- Load carrying capacity can be increased by giving shape to the sheet iron.
- 300mm equally spaced traverse structure
- TS EN ISO 1461 standard hot-dip production
- Wide range of accessories
- Fire resistance certificates (E30-E60-E90)
- Galvanized steel painted finish available on request (epoxy, epoxy polyester, polyester)

#### Overview

E-Line KME cable ladders are designed to route the cabling in facilities and buildings in internal or external environments on vertical shafts thanks to its high load bearing capacity.

#### Applications

- Suitable for internal and external environment
- Industrial plants
- Skyscrapers
- Textile and confection plants
- Automotive plants
- Shipyards
- Malls, hospitals
- Conference centres
- Car parking areas
- Oil&Gas plants
- Tunnels; rail systems, bridges, underpasses

## E-LINE CT

### Hot-dip Galvanized Cable Tray Systems

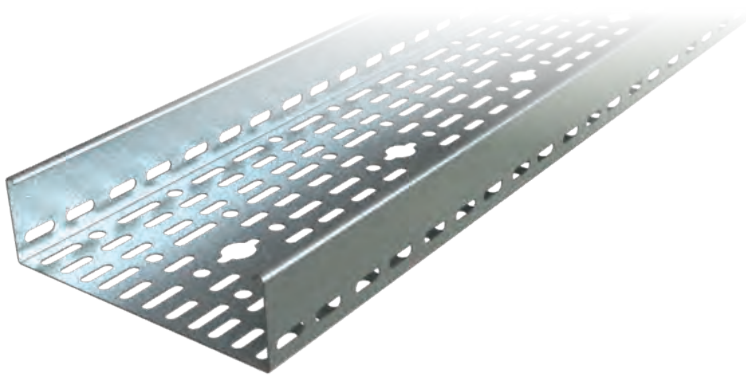

#### Features

- Heavy duty and regular types
- 40/50/60/75/100/125/150mm tray heights
- 50/100/150/200/250/300/400/500/600 widths (700-800-900 special widths on request)
- 0,8/1/1,2/1,5/2mm thickness
- 3000mm length (6000mm special length on request)
- TS EN ISO 1461 standard hot-dip and after special EAE protective coating over hot dip
- Possibility to connect the various accessories that 20,5 diametres hole in the middle of the tray
- Wide range of accessories
- Fire resistance certificates (E30-E60-E90)
- Galvanized steel painted finish available on request (epoxy, epoxy polyester, polyester)

#### Overview

E-Line CT series hot-dip galvanized cable trays are designed to carry the cabling in indoor or outdoor installations internally or externally in factories and buildings, especially in humid or vaporous environments. They can also be manufactured as pre-galvanized upon request.

#### Applications

- Suitable for internal and external environment
- Industrial plants
- Skyscrapers
- Textile and confection plants
- Automotive plants
- Shipyards, airports
- Malls, hospitals
- Conference centres
- Car parking areas
- Oil&Gas plants
- Tunnels; rail systems, bridges, underpasses

# CABLE TRAY SYSTEMS

## E-LINE CTK

### Hot-dip Snap On Covered Cable Duct Systems



#### Features

- Heavy duty type
- 60 / 75 / 100mm heights
- Thickness: 1.5mm for 100/150/200/250/300mm 2mm for 400/500/600mm
- 3000mm length (6000mm special length on request)
- Plug cover structure
- TS EN ISO 1461 standard hot-dip and after special EAE protective coating over hot dip
- Possibility to connect the various accessories that 20,5 diametres hole in the middle of the tray (Allows fast mounting for devices such as lighting panel, fire detector etc.)
- Wide range of accessories
- Fire resistance certificates (E30-E60-E90)
- Galvanized steel painted finish available on request (epoxy, epoxy polyester, polyester)

#### Overview

E-Line CTK series hot dip snap on cover cable tray systems can be easily mounted without the need for cover fixings thanks to the special bends on the cover and the tray.

#### Applications

- Parking areas
- Chemical plants
- Factory and industrial facilities
- Food plants
- Power plants

## E-LINE TLS

### Wire Mesh Cable Trays



#### Features

- 35-55-85-100mm heights
- 4-5mm thicknesses of horizontal and vertical wires
- Product structure is formed by a combination of wires from 100mm in the vertical direction, 50mm in the horizontal direction
- Electro-galvanized and stainless production (hot-dip on request)
- Possibility of ready to turn components, external cutting-combining methods and modules
- 3000mm length

#### Overview

E-line TLS series wire mesh cable trays allows for downward outputs and to the right or left between the wires to be easily made thanks to the cage structure of wire mesh tray systems. Products are produced as stainless steel or electro-galvanized plated options.

#### Applications

- Food plants
- Data computing rooms
- Raised floor applications

# CABLE TRAY SYSTEMS

## E-LINE KCA - CTA GRP

Pultruded Fiberglass Reinforced Polyester

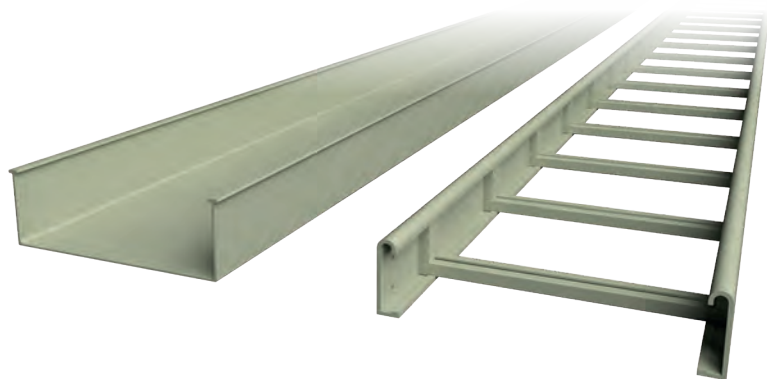

### Overview

KCA GRP; It sets the industry standard for cable support systems around the world. It has a unique combination of high strength, flexibility and lightweight design. Designed for highest load strength in its class, high resistance to impacts and environmental forces.

### Features

- Non-flammable material (Class I – ASTM E84)
- Self-extinguishing (UL 94 "V0" Classified)
- When exposed to flame, No toxic fumes.
- Zero halogen
- Low flame spread index
- Low smoke density
- Insulating
- Extremely-light weight

### Applications

- Tunnels
- Mining industry
- Thermal power plants
- Chemical power plants
- Geothermal power plants
- Hydroelectric power plants
- Nuclear power plants
- Heavy industrial manufacturing facilities
- Refineries
- Oil platforms
- LNG terminals and pump stations
- Urea and ammonia production facilities
- FSRU projects
- Floating power plants

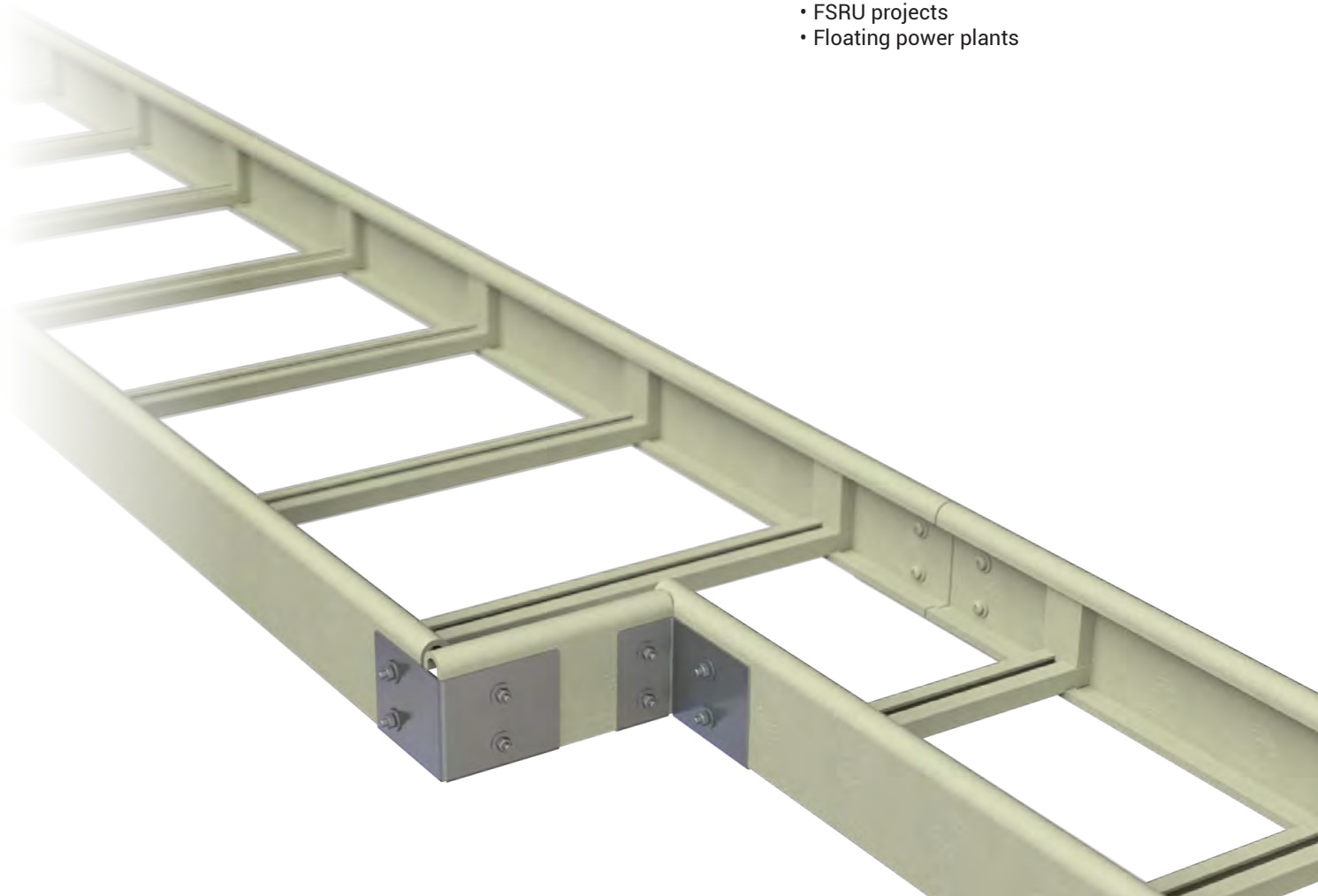

# CABLE TRAY SYSTEMS

## E-LINE KCA OG

### Cable Ladder Systems

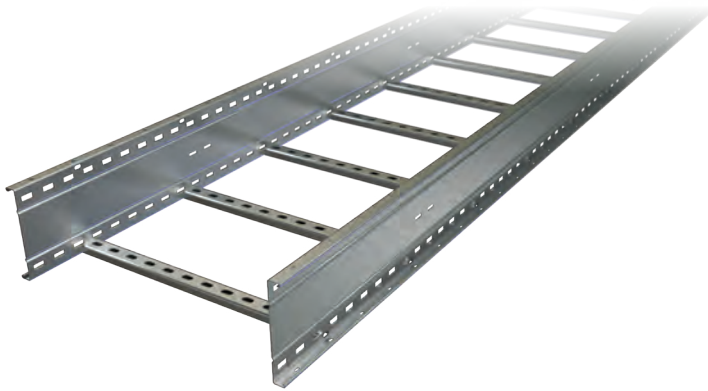

#### Features

- 6mt the is standard length and construction of the ladder is in accordance with 6mt suspension ranges
- NEMA VE 1 Standard compliance and certification
- Maximum cable bearing with Extra Heavy Duty Type Structure
- High quality raw material selection (Corten A - SS 316L)
- High Production Capacity
- Fast Track delivery period
- Flexible Production against different specifications
- With the special form of the side rail, cable bearing capacity is upgraded
- Tested for hazardous conditions
- According to DIN4102-12 standard, it was tested at a temperature of 1000 °C for 90 minutes
- It has successfully passed the -70 °C degree test

#### Overview

E-Line KCA OG has a reputation for setting the industry standard for cable support systems across all around world. E-Line KCA OG has a unique combination of high strength, resilience, and lightweight design. E-Line KCA OG Cable Ladder range is engineered for the ultimate load bearing strength in its class, high resistance to impact and environmental forces, while also achieving all weight reductions possible.

#### Applications

- Thermal Power plants
- Combine Cycle Power Plants
- Geothermal Power Plants
- Nuclear Power Plants
- Production Facilities (Glass, Steel, Cement etc.)
- Refineries
- Oil Platforms
- LNG Terminals and Pumping Stations
- Urea and Amonium Plants

## E-LINE KCA AL

### Aluminium Cable Ladder Systems

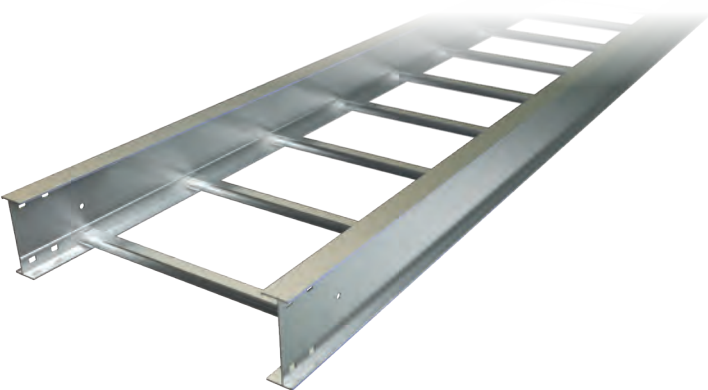

#### Features

- 6mt the is standard length and construction of the ladder is in accordance with 6mt suspension ranges
- NEMA VE 1 Standard compliance and certification
- Maximum cable bearing with Extra Heavy Duty Type Structure
- Material: Extruded Aluminum Alloy 6063-T6 (Also called marine grade Aluminum and copper-free Aluminum)
- High Production Capacity
- Fast Track delivery period
- Flexible Production against different specifications
- With the special form of the side rail, cable bearing capacity is upgraded
- Tested for hazardous conditions

#### Overview

E-Line KCA AL aluminium cable ladder sections are designed to comply with NEMA VE-1 and IEC 61537 load requirements.

#### Applications

- Thermal Power plants
- Geothermal Power Plants
- Hydroelectric Power Plants
- Nuclear Power Plants
- Heavy Industry Production Facilities
- Refineries
- Oil Platforms
- LNG Terminals and Pumping Stations
- Urea and Amonium Plants
- FSRU Projects
- Floating Solar Plants

# TROLLEY BUSBAR SYSTEMS

## E-LINE TROLLEY BUSBAR

Trolley Busbar Systems 35A...250A

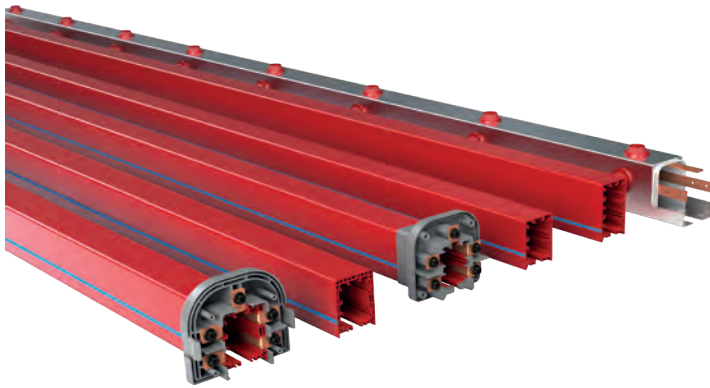

### Features

- 35A...250A current ranges
- Standard 4 or 7 conductors (3, 5, 6 conductors on request)
- Uninterrupted copper conductors
- PVC body
- Standard 4m lengths

### Overview

E-Line TB series and URC series Trolley Busbar Systems are designed to supply power to moving machines. The busbar's current reception carrier has carbon brushes and is mechanically fixed to the moving together with the machine.

### Applications

- Hoists and cranes
- Confection plants
- Moving assembly lines
- Automated warehouses
- Similar places

## E-LINE URC

Trolley Busbar Systems 320A...1000A



### Features

- 320A...1000A current ranges
- Aluminium, copper or galvanized steel conductors
- PVC exterior insulation
- 6m for aluminium conductors and 4m for copper and galvanized steel conductors are standard lengths
- Suitable for indoor and outdoor

### Overview

URC (Uni-Rail Conductor) Busbar systems are the systems where each conductor is installed as a separate line and the current reception cars act together with the machine that will use the energy to realize the continuous power reception.

### Applications

- Port, construction and industrial cranes
- AS/RS storage systems
- Moving playground systems
- Moving door and ceiling systems
- Installation and testing lines
- Monorail systems
- Lift system

# FIT-OUT SOLUTIONS

## DABLINE

Raised Floor Power Distribution Systems 63A-80A



### Features

- Manufactured in accordance with IEC 61439-6 standard. It has DEKRA and TSE certifications
- The body with IP55 protection level includes outputs at every 30 or 60cm
- With completely insulated conductors and silver coated tulip formed enhanced contacts offers perfect and safe utilization
- Each busbar length is equipped with integral adjustable fixing brackets
- With its ultra slim structure and horizontal utilization properties and output plug options, it can be used comfortably beneath a 10cm raised floor

### Overview

DABLINE busbar systems, which has different colour options, is used for raised floor applications in offices. The small size of DABLINE makes it possible to install the system into very narrow places even up to 65mm floor height.

Does not require cable duct, cable, junction and connector. Manufactured in either 63A or 80A current rated versions with tap off plugs rated 13A to 32A.

### Applications

- Banks
- Business centres
- Modern offices
- Hotels
- Hospitals
- Cinema and theatre buildings
- Conference centres
- Courses
- Resorts etc.
- Any other application with a raised floor in the building

## E-LINE NDK

Modular and Compact Solutions For Under Floor and Raised Flooring



### Features

- Socket box options with 3, 8, 16 or 24 module capacity
- Compliant with circuit protection elements such as MCB, RCD and RCDBO
- Manufactured with EN 50085-2:2008 standard compliance, has DEKRA and TSE certificates
- All plastic parts are "halogen free" and compliant to 960°C glow wire test as per IEC 60965, with V2 flame retardent class as per UL94

### Overview

Stylish, safe and innovative design, modular and compact solutions...

The underfloor and raised floor power distribution systems that save office etc environments from cable stacks and offer streamlined cabling. Can be adapted when offices or work places are moved around or capacity increases.

### Applications

- Banks
- Offices
- Hospitals
- Hotels
- Schools and classrooms
- Malls
- Conference centres
- Call centers
- Trading Rooms
- Cinema and theatre buildings
- Industrial plants
- Tourist facilities

# FIT-OUT SOLUTIONS

## E-LINE MINI

### Mini Series Pop-up and IP66 Outlet Boxes

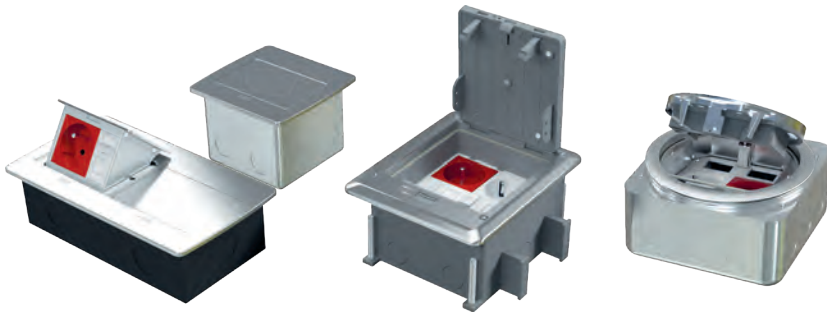

#### Features

##### IP40 Series Products:

- Soft opening covers
- Plastic socket plate for modular type (45x45mm and 22.5x45mm) power, data, telephone and multimedia outlets
- Suitable structure for desk, raised floor and under screed applications
- 3 Modules and 6 Modules options

##### IP66 Series Products:

- Two stage opening cover structure
- Plastic socket plate for modular type (45x45mm and 22.5x45mm) power, data, telephone and multimedia outlets
- Suitable structure for underscreed and raised floor application and back box with pipe entry
- Six (6) modules outlet capacity
- Special locking mechanism on the cover eliminating cable crushes

#### Overview

Add value to your working environment with the pop-up series products. Get power from the nearest point with its accessibility and stylish finish. Can be used in tabletop, under screed or raised floor applications. Select the module (3/6 modules) you need and customize them using the range of available outlets.

#### Applications

- Residential Buildings
- Shopping Centres
- Airports
- Factory / Workshop
- Administrative Buildings Offices
- Hotels
- Hospitals / Health Centres
- Sport Centres

## E-LINE SMART

### Multi-Outlet Extension Blocks



#### Features

- The ELINE SMART range offers comfort, style and functionality for users in living and working environments; available equipped or non- equipped to accept power and data sockets
- Compatible structure with offices, meeting rooms, every desk and in specific work areas and open office furniture
- Energy and low-voltage sockets can be used optional wide cable terminations for today's office needs
- Modular structure and innovative design with anodized aluminium body and polycarbonate covers, 8, 10, 12, 14, 16 and 18 modules are standard production capacity. Aesthetics and high-performance products can be produce optional comfortable with special production opportunities in different sizes and equipment

#### Overview

Products ensure high ease of use, depending on your personal needs and preferences with modular type power and low voltage sockets. Products are 7 different types, according to size in socket needs, universal and modular design makes it suitable to accept any brand of socket. Built-in type or free standing on the office desk and furniture; offers flexible and definitive solution for mains, UPS, data, telephone and multimedia needs.

#### Applications

- Banks
- Business Centres
- Modern offices
- Hotels
- Hospitals
- Conference centres
- Courses
- Resorts etc.

# FIT-OUT SOLUTIONS

## E-LINE E-BOX

### Socket Combination Box



#### Overview

The E-BOX SOCKET COMBINATION BOX series is designed for use in factories, construction sites, workshops, and work environments. It combines sockets and functions as an electrical installation box for circuit protection and distribution...

#### Features

- IP42 Protection Class
- The plastic frame material of the product is PA6, halogen-free, and meets the UL94 standard with a V2 fire resistance rating
- Operating voltage of 230/400V AC
- Various configuration options are available, with a maximum current rating of 63A
- It is suitable for mounting 16A, 240V socket type panels (Schuko) and 63A, 415V CEE standard socket type industrial plugs
- It includes a compartment with 11 modules for miniature circuit breakers (MCB) and/or residual current devices (RCD), featuring breakable plates, a padlock attachment, and a transparent cover

#### Applications

- Factories and workshops
- Construction sites
- Business Centres and offices
- Warehouses
- Car Parks
- Electrical installation areas



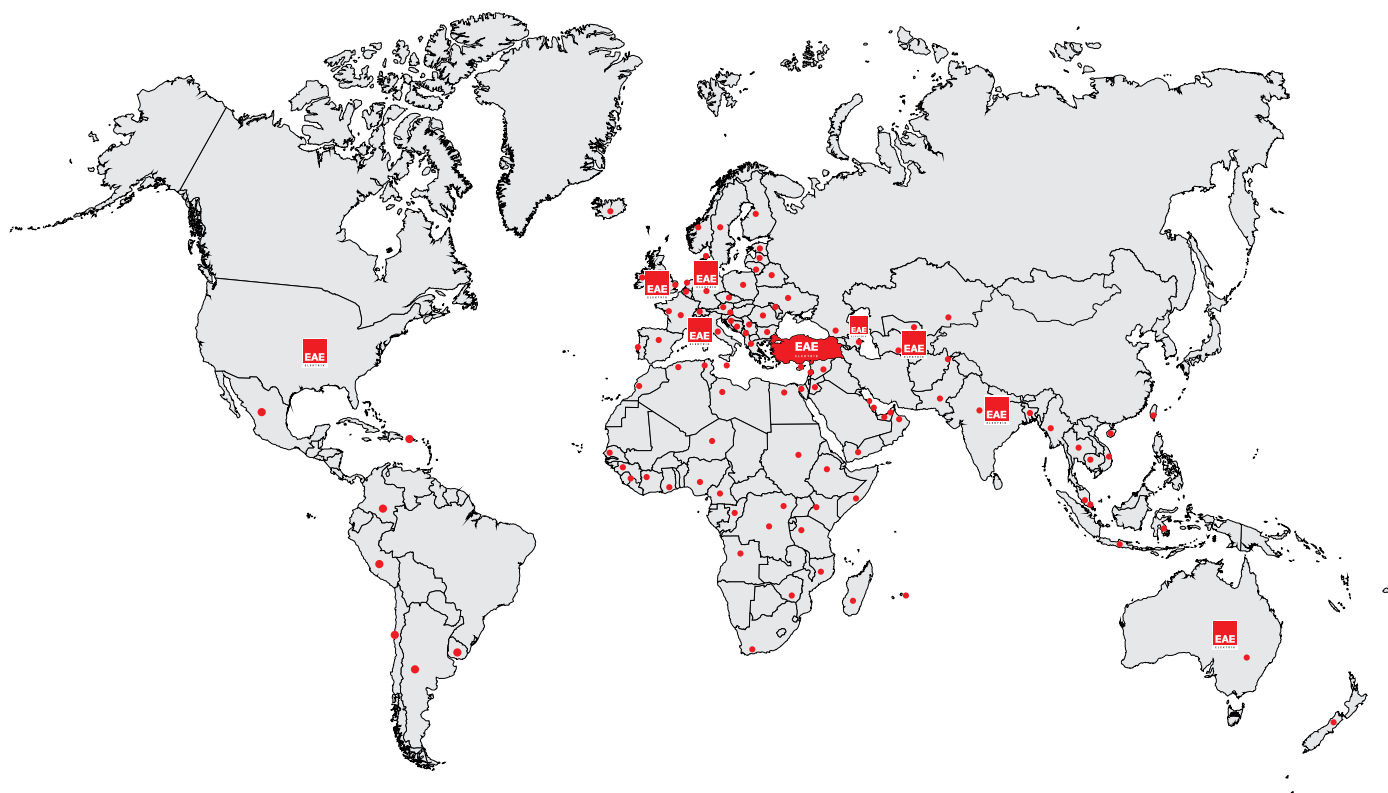

- |                          |                                  |                 |                |
|--------------------------|----------------------------------|-----------------|----------------|
| AFGHANISTAN              | GHANA                            | KOSOVO          | RWANDA         |
| GERMANY                  | GUINEA                           | KUWAIT          | SENEGAL        |
| UNITED STATES OF AMERICA | SOUTH AFRICA                     | NORTH MACEDONIA | SERBIA         |
| ANGOLA                   | SOUTH KOREA                      | LATVIA          | SINGAPORE      |
| ARGENTINA                | GEORGIA                          | LIBERIA         | SLOVAKIA       |
| ALBANIA                  | CROATIA                          | LIBYA           | SLOVENIA       |
| AUSTRALIA                | INDIA                            | LITHUANIA       | SOMALIA        |
| AUSTRIA                  | HOLLAND                          | LEBANON         | SRI LANKA      |
| AZERBAIJAN               | NETHERLANDS ANTILLES             | LUXEMBOURG      | SYRIA          |
| BAHRAIN                  | HONG KONG                        | HUNGARY         | CHILE          |
| BANGLADESH               | IRELAND                          | MADAGASCAR      | TAJIKISTAN     |
| BELGIUM                  | SPAIN                            | MALAYSIA        | TANZANIA       |
| UAE EMIRATES             | SWEDEN                           | MALTA           | TATARSTAN      |
| UNITED KINGDOM           | SWITZERLAND                      | MAURITIUS       | THAILAND       |
| BOSNIA AND HERZEGOVINA   | ITALY                            | MEXICAN         | TAIWAN         |
| BULGARIA                 | ICELAND                          | EGYPT           | TUNISIA        |
| ALGERIA                  | CAMBODIA                         | MOLDOVA         | TURKMENISTAN   |
| DJIBOUTI                 | CAMEROON                         | MYANMAR         | UKRAINE        |
| CZECHIA                  | MONTENEGRO                       | NEPAL           | OMAN           |
| DENMARK                  | QATAR                            | NIGER           | URUGUAY        |
| INDONESIA                | KAZAKHISTAN                      | NIGERIA         | JORDAN         |
| ESTONIA                  | KENYA                            | NORWAY          | VIETNAM        |
| ETHIOPIA                 | KYRGYZSTAN                       | UZBEKISTAN      | VIRGIN ISLANDS |
| MOROCCO                  | CYPRUS                           | PAKISTA         | YEMEN          |
| IVORY COAST              | COLOMBIA                         | PERU            | NEW ZEALAND    |
| PALESTINE                | CONGO                            | POLAND          | GREECE         |
| FINLAND                  | DEMOCRATIC REPUBLIC OF THE CONGO | PORTUGAL        | ZAMBIA         |
| FRANCE                   |                                  | ROMANIA         | ZIMBABWE       |

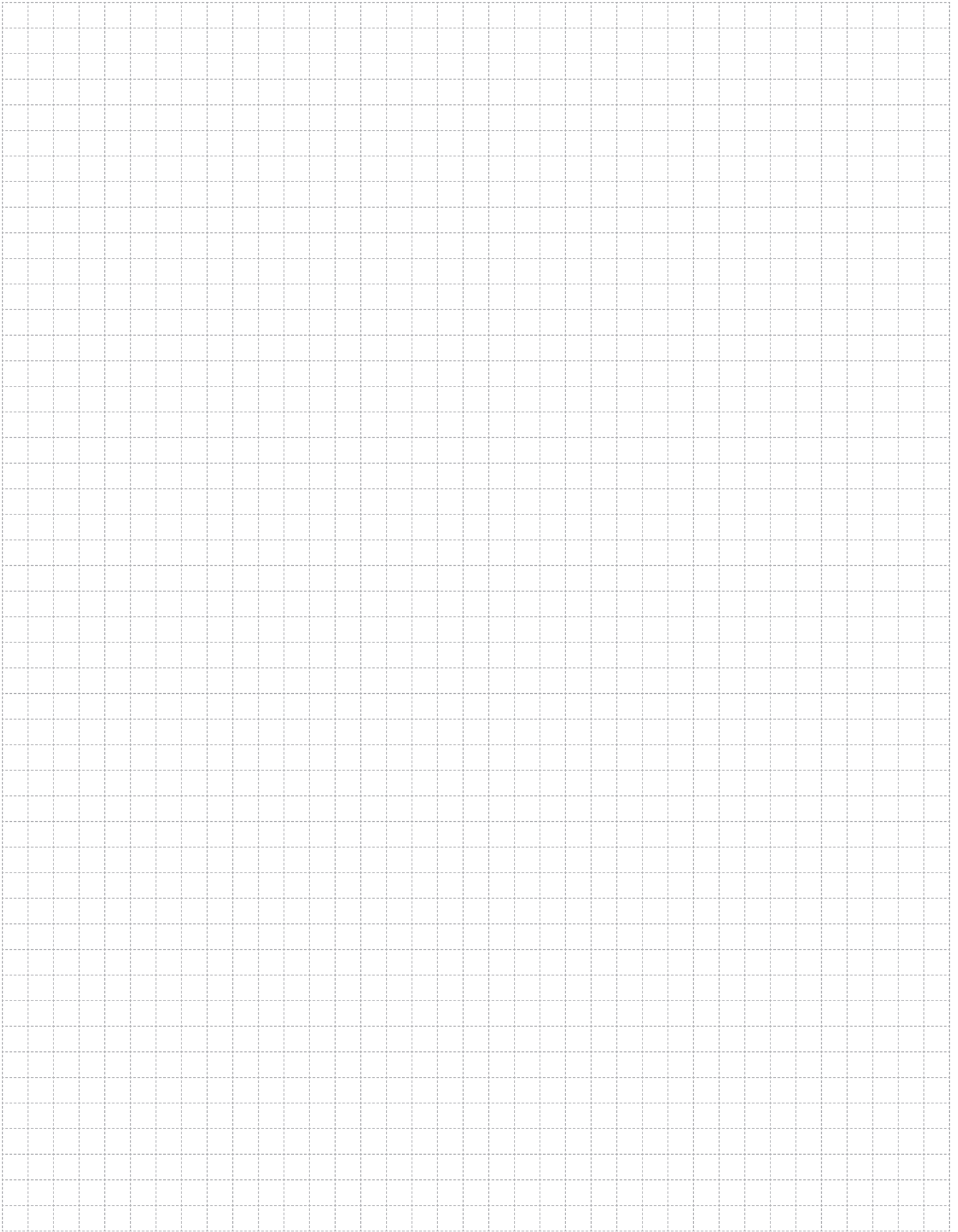

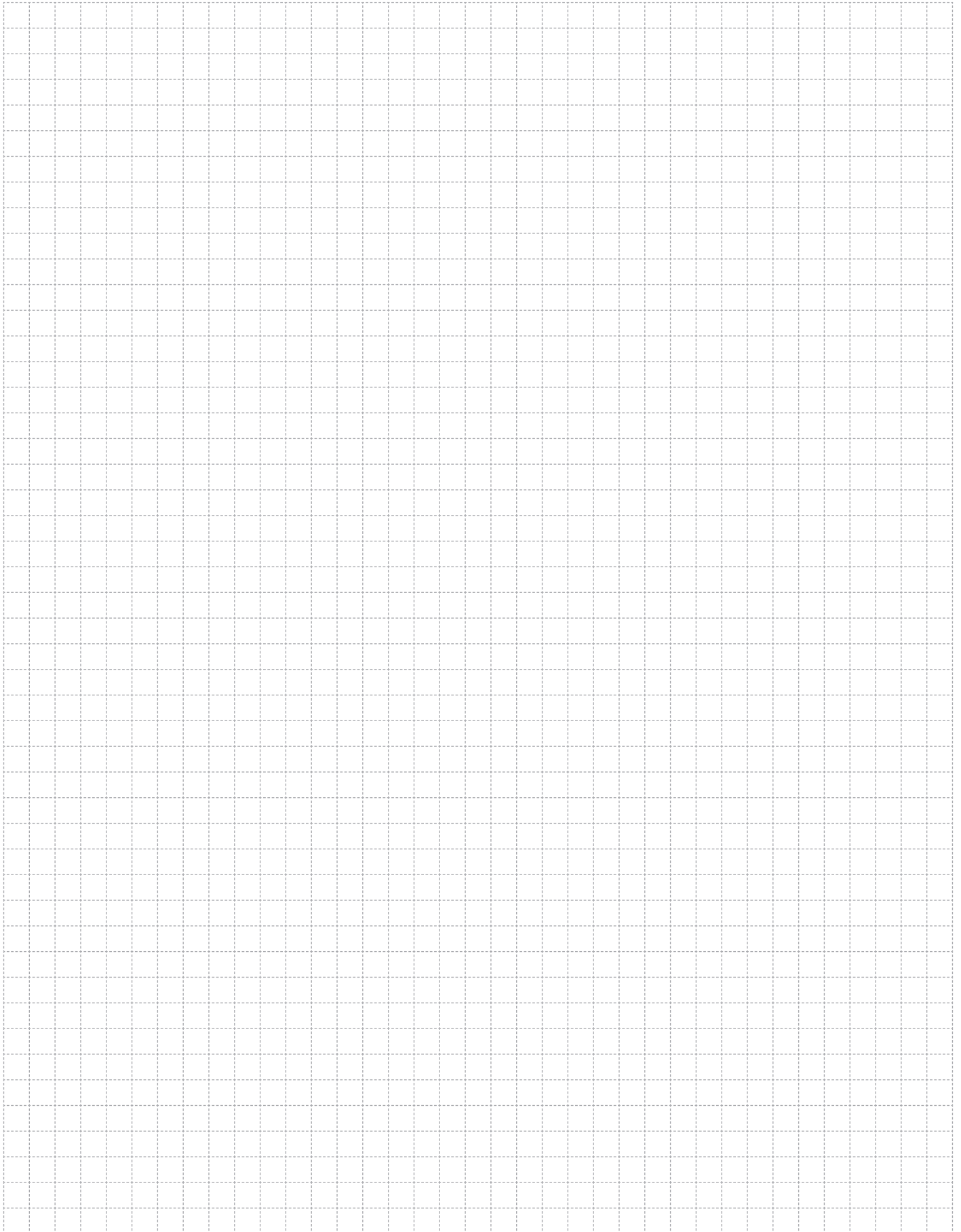

# SUSTAINABLE FUTURE

## Sustainability Management at EAE Elektrik



As part of our goal to support sustainable development and green transformation, measuring, evaluating, and managing all economic, environmental, and social impacts resulting from our sustainability practices is a key governance priority for EAE Elektrik. We act with great care in analyzing, monitoring, and managing the economic, environmental, and social impacts and risks that arise throughout our value chain in both our national and global operations.

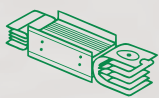

Busbar Systems

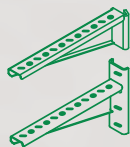

Support Systems

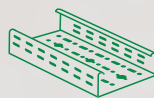

Cable Tray Systems

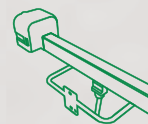

Trolley Busbar Systems



Fit-Out Solutions

*"We are working together with all our stakeholders to develop the electrical technologies that will build the future."*

You can visit our sustainability website at [sustainability.eaeelectric.com](https://sustainability.eaeelectric.com)



**EAE Elektrik**

**Head Office**

Akcaburgaz Mahallesi,  
3114. Sokak, No: 10 34522  
Esenyurt - Istanbul - Turkiye  
Tel: +90 (212) 866 20 00  
Fax: +90 (212) 886 24 20

**EAE DL 1 Factory**

**Cable Tray**

Organize Sanayi Bolgesi Mahallesi,  
6. Cadde, No: 2E, 41455  
Dilovasi - Kocaeli - Turkiye  
Tel: +90 (262) 999 05 55  
Fax: +90 (262) 502 05 70

**EAE DL 3 Factory**

**Busbar**

Organize Sanayi Bolgesi Mahallesi,  
6. Cadde, No: 6A, 41455  
Dilovasi - Kocaeli - Turkiye  
Tel: +90 (262) 999 05 55  
Fax: +90 (262) 502 05 69

**EAE DL 4 Factory**

**Busbar 2**

Organize Sanayi Bolgesi Mahallesi,  
6. Cadde, No: 14/10, 41455  
Dilovasi - Kocaeli - Turkiye  
Tel: +90 (262) 999 05 55  
Fax: +90 (262) 502 01 45



Please visit our website for the updated  
version of our catalogues.  
[www.eaeelectric.com](http://www.eaeelectric.com)



Catalogue 02 - En. / Rev. 12 1000 Pcs. 10/02/2026  
N.G.

EAE has full right to make any revisions or changes on this catalogue without any prior notice.