

# E-LINE TBX-S



• Bridge Cranes



• Monorail Systems

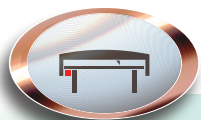

• Textile Cutting and Spreading Tables



• AS/RS Storage Systems



• Moving Ceiling and Door Systems

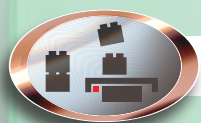

• Assembly and Test Lines

## **E-LINE TBX-S**

---

Trolley Busbar Systems .....	2
Order Code System .....	3
TBX-S Trolley Busbar .....	4
TBX-S Feeder Unit .....	5-6
TBX-S Repair Zone Module .....	7
TBX-S Current Collector .....	8-9
System Components .....	10-11
Voltage Drop, Calculation Of Feeding Points .....	12
TBX-S Trolley Busbar Installation Manual .....	13-14

# E-LINE TBX-S

## Trolley Busbar Systems



- Bridge Cranes
- Monorail Systems
- Textile Cutting and Spreading Tables
- AS/RS Storage Systems
- Moving Ceiling and Door Systems
- Assembly and Test Lines

It consists of copper conductors and current collectors in the C-PVC body. The uninterrupted energy supply and movement of the system is provided by current collectors connected to the system mechanically.

The eliminates the possibilities such as accident, malfunction in energy distribution with suspended and reel cable in conventional systems. Conductors are enclosed in C-PVC housing and personnel safety is maximized.

There is no fixed connection between the conductor housings and the conductors and between the C-PVC housing and the sliding hangers, the necessary expansion opportunity is provided, therefore the expansion element is unrequired.

### Cautions:

If it is used in external environments exposed to rain, it is recommended to protect it with a cover such as a canopy.



# E-LINE TBX-S

## Order Code System

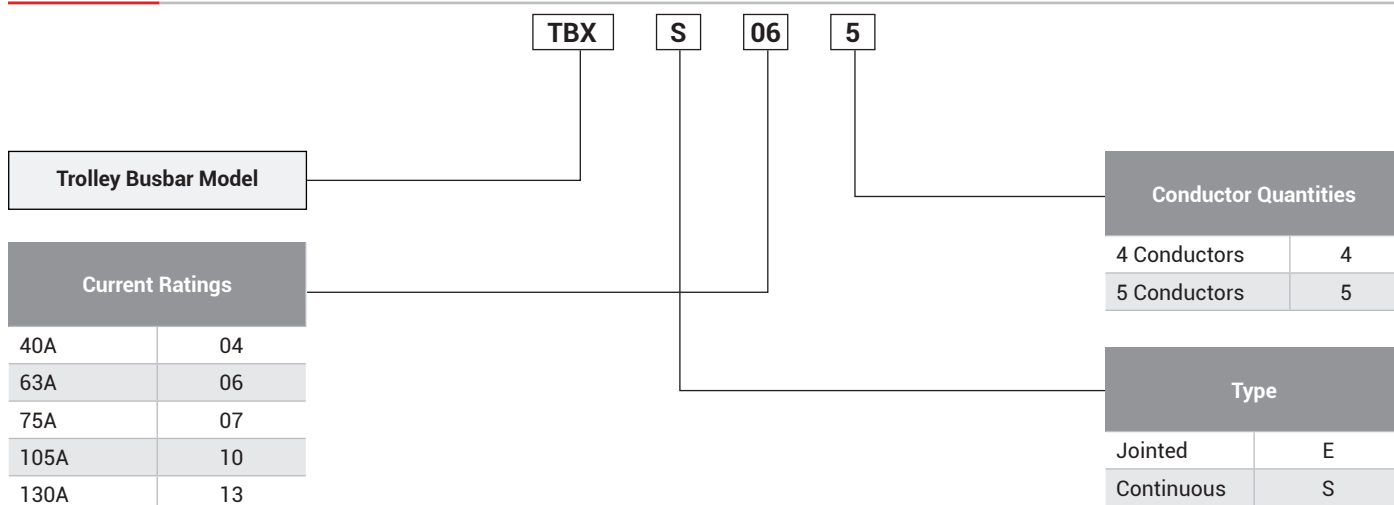

TBX-S

## Technical Features

Rated Current	(A)	40	63	75	105	130
Conductor Quantities	(pcs)	4-5	4-5	4-5	4-5	4-5
Rated Voltage	(AC) (V)	690	690	690	690	690
Dielectric Properties	(kV/mm)	30	30	30	30	30
Frequency	(Hz)	50/60	50/60	50/60	50/60	50/60
Resistance (20°C)	R20 (mΩ/m)	1,300	1,018	1,280	0,800	0,570
Resistance (35°C)	R35 (mΩ/m)	1,420	1,176	1,460	0,920	0,660
Reactance	X (mΩ/m)	0,160	0,447	0,140	0,060	0,250
Impedance	Z (mΩ/m)	1,429	1,258	1,467	0,922	0,706
Standard Length	(m)	4	4	4	4	4

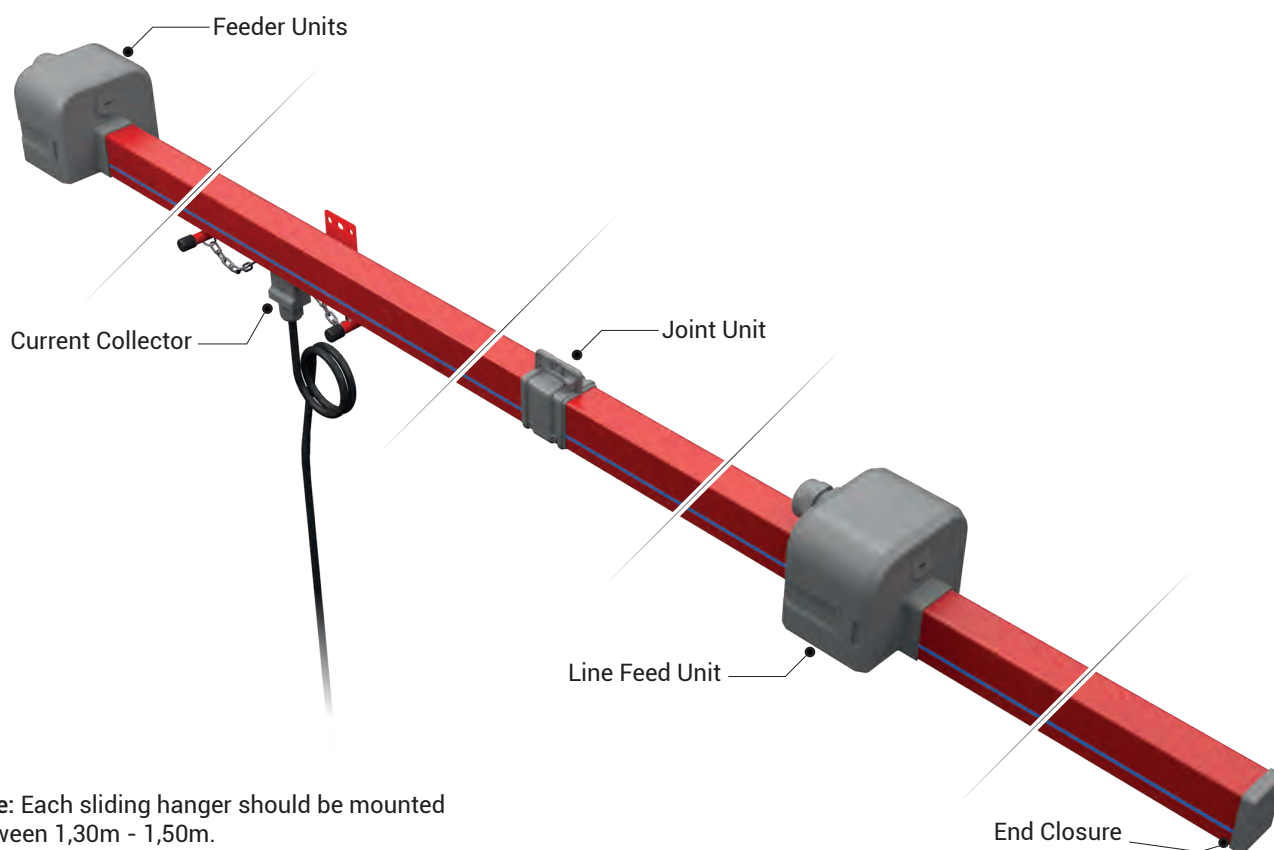

**Note:** Each sliding hanger should be mounted between 1,30m - 1,50m.

## TBX-S Trolley Busbar

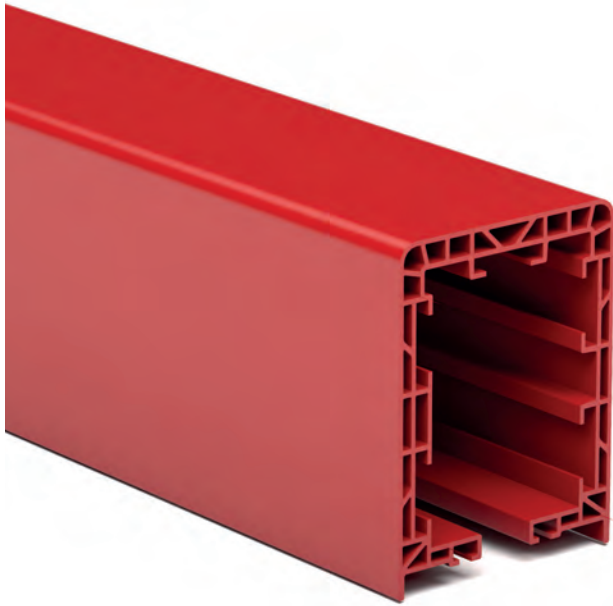

Description	Weight (gr/m)	Order Code
TBX-S Trolley Busbar Housing	820	2067393

The housing has a structure that can use maximum 5 conductors. There is safety system that prevents the current collector to be fixed inversely.

### Continuous Copper Conductors

Electrolytic copper conductors can be applied without interruption at a maximum length of 150m.

- **Number of Conductors:** 4 or 5 conductors
- **Colour:** Red.
- **Temperature range:** -40°C and +55°C.
- **Standard housing length:** 4 meters.
- **Protection:** Standard IP24, Gasket, IP44.
- **Non-Flammable Characteristics:** UL 94 V0
- Housing is made of C-PVC and plastic accessories are made of PA6 raw material.
- There is a neutral line on the housing the neutral conductor.
- Light and durable with double layer structure, TBX provides ease of installation.

### Standard 4 Meters

Model	Conductors Quantity-Current (A)	Weight (gr/m)	Conductor Cross Section (mm <sup>2</sup> )	Order Code
TBX-S 044	4P - 40A	1250	4x11,20	3233922
TBX-S 064	4P - 63A	1300	4x12,80	3135807
TBX-S 074	4P - 75A	1400	4x16,00	3135809
TBX-S 104	4P - 105A	1650	4x24,00	3135811
TBX-S 134	4P - 130A	1950	4x32,00	3135813
TBX-S 045	5P - 40A	1350	5x11,20	3233923
TBX-S 065	5P - 63A	1400	5x12,80	3135808
TBX-S 075	5P - 75A	1500	5x16,00	3135810
TBX-S 105	5P - 105A	1900	5x24,00	3135812
TBX-S 135	5P - 130A	2250	5x32,00	3135814

Joint plastics are not included in the weight values.  
Total weight of the joint plastics and bolts is 100 kg.

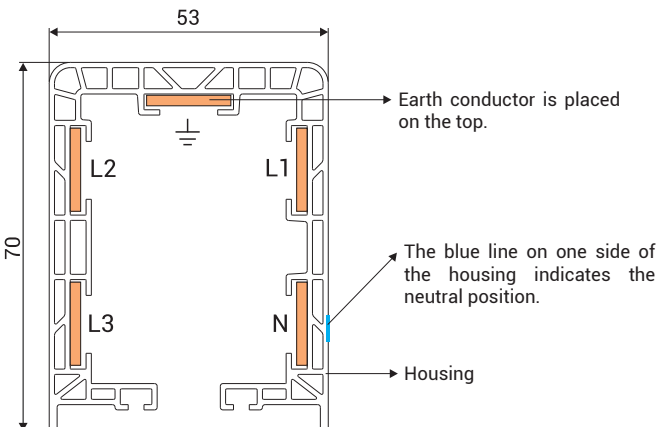
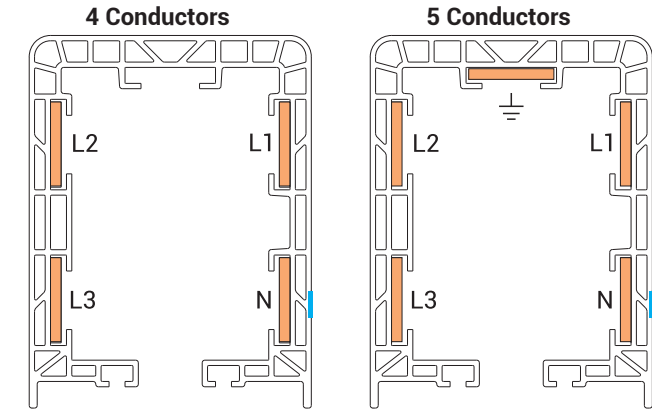

### Radius Trolley Busbar

It has minimum 1,5m radius Trolley Busbar available in vertical axes. Radius Trolley Lines can be applied with maximum 4 conductors.

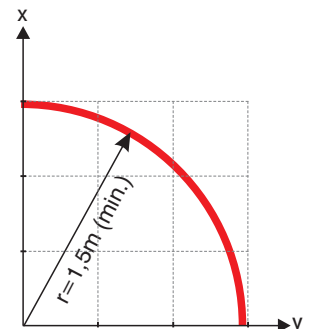

# E-LINE TBX-S



## TBX Feeder Box

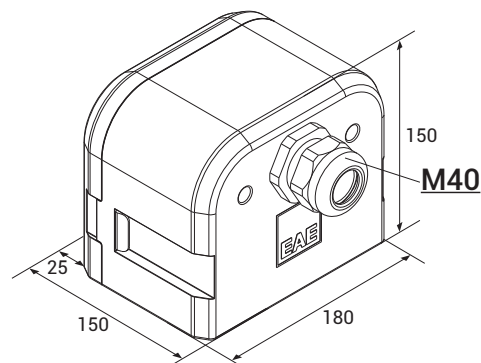

TBX-S

Description	Weight (gr)	Order Code
TBX Feeder Box	750	3135798

Type of the feeding element is selected by calculating the voltage drop and the location of the power supply that shall provide power to the system.

## TBX-S End Closure

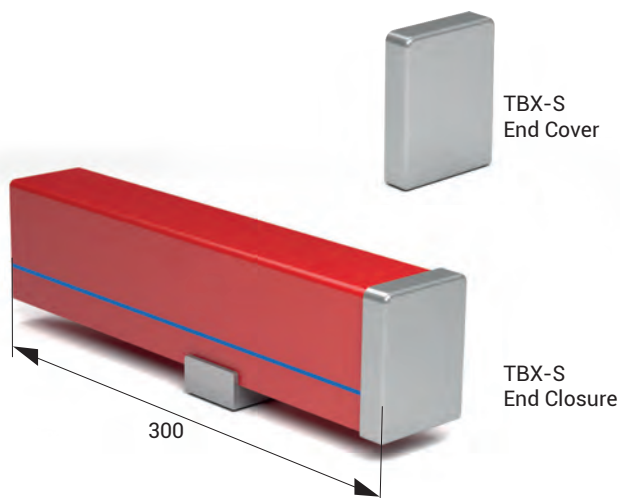

The end closure placed on the end of the busbar line prevents the exposure of the conductors, protects the system, and prevents the current collector from moving out of the housing.

Description	Weight (gr)	Order Code
TBX-S End Closure	450	3135816
TBX-S End Cover	25	1022212

## TBS Joint Unit

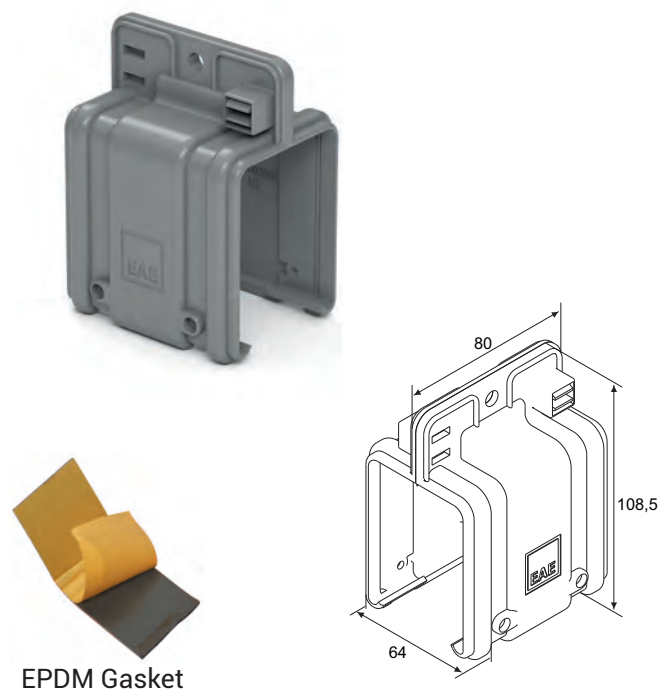

Description	Weight (gr)	Order Code
TBS Joint Unit	90	1003663

# E-LINE TBX-S



## TBX-S Line Feed Unit - Continuous Type

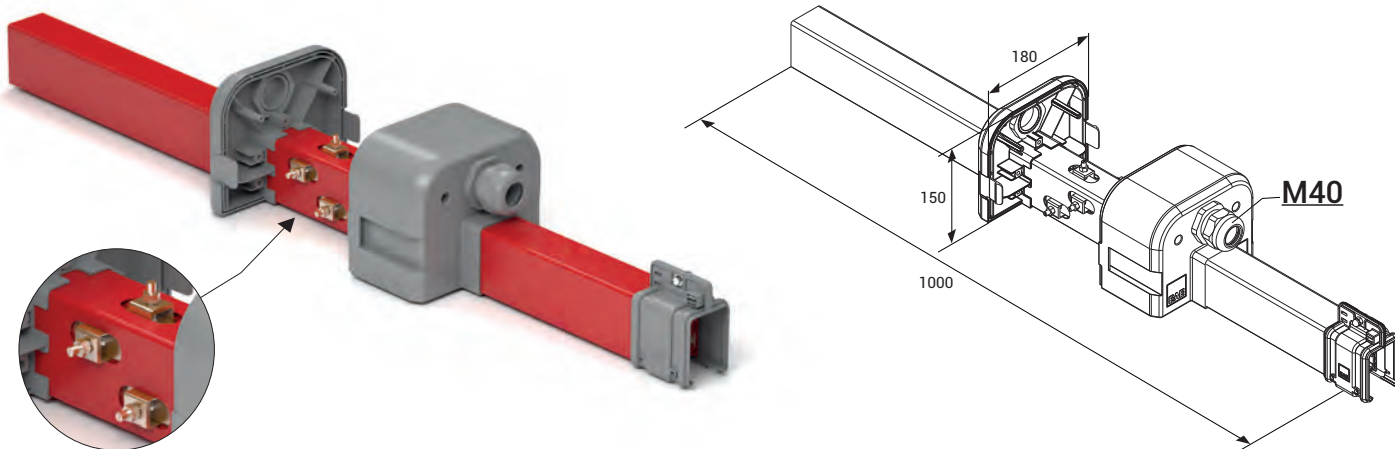

Description	Weight (gr)	Order Code
TBX-S Line Feed Unit - Continuous Type	1650	3136706

Type of the feeding element is selected by calculating the voltage drop and the location of the power supply that shall provide power to the system.

## TBX-S Line Feed Unit - Jointed Type

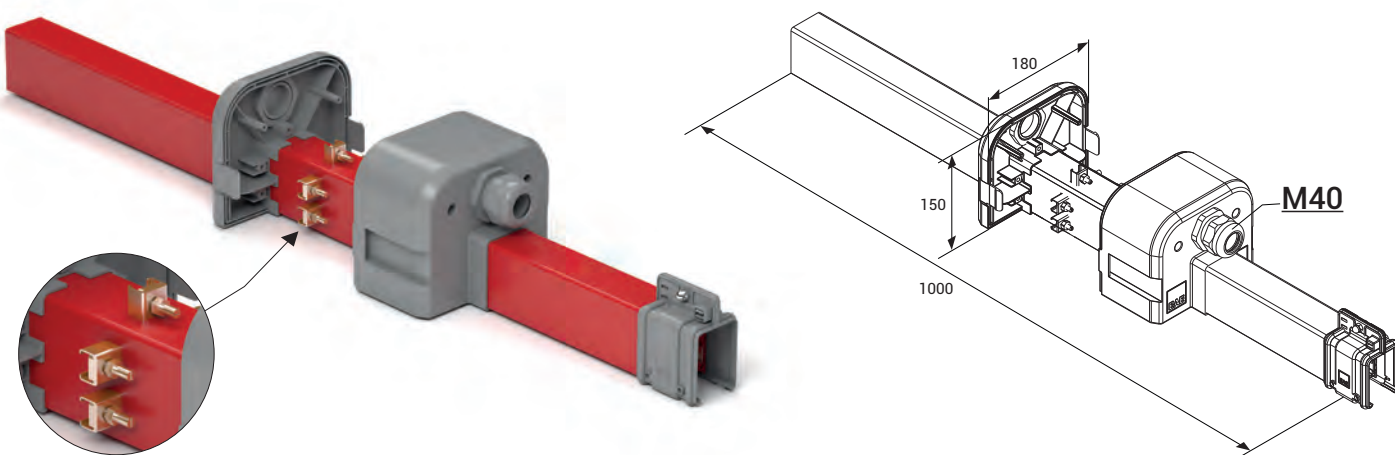

Description	Weight (gr)	Order Code
TBX-S Line Feed Unit - Jointed Type	1650	3135818

Type of the feeding element is selected by calculating the voltage drop and the location of the power supply that shall provide power to the system.

## TBX-S Repair Zone Unit

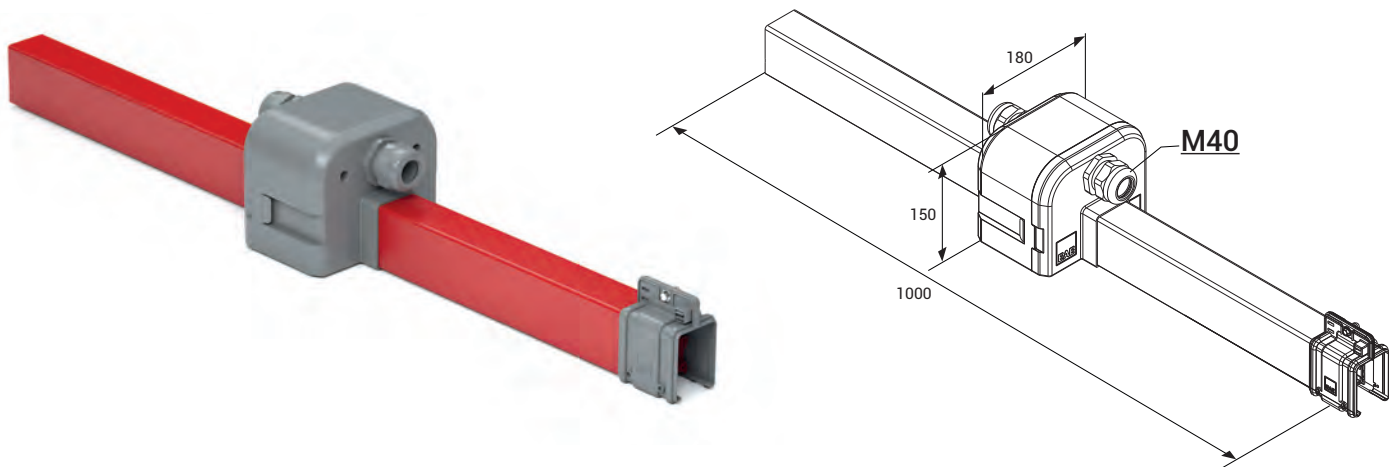

TBX-S

Description	Weight (gr)	Order Code
TBX-S Repair Zone Module	2050	3135817

Current supply shall be cut off when a machine working on the line shall be maintained or repaired. Repair zone module is used to create a currentless area on the busbar so that the other machines operating on the same line may continue to work.

## TBX-S Current Collector Replacement Module

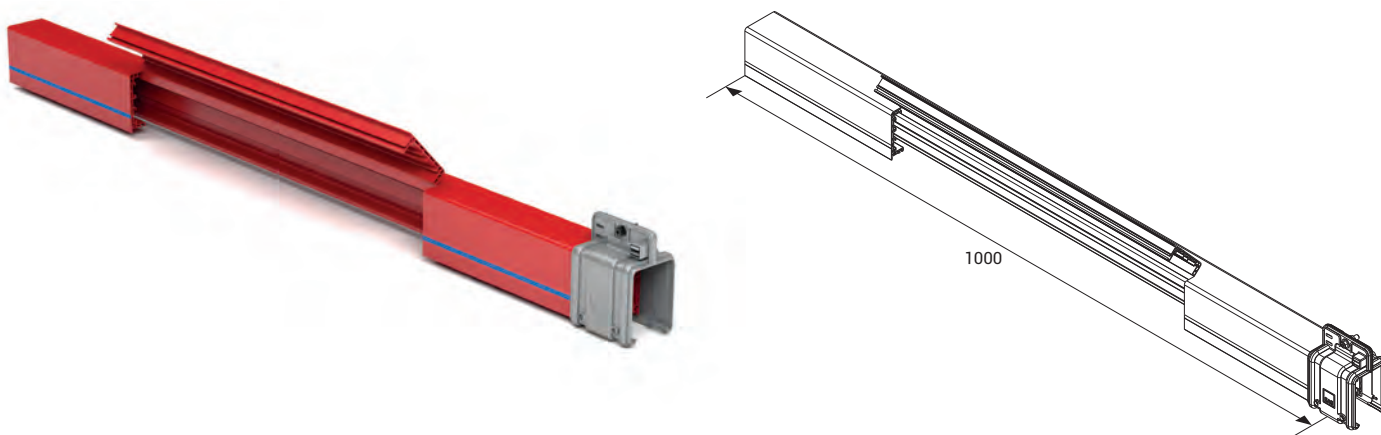

Description	Weight (gr)	Order Code
TBX-S Current Collector Replacement Module	1100	3233921

This unit is used to remove an existing current collector or to add extra trolleys. The unit is obtained by cutting a 50cm section from the PVC housing.

# E-LINE TBX-S



## TB5 Current Collectors With Cable

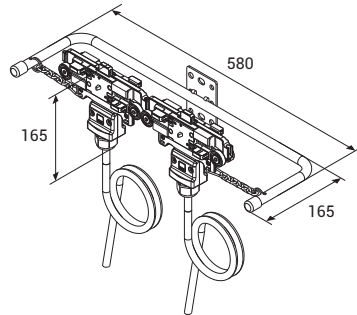
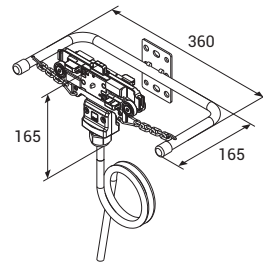

Model	Brushes Number-Current (A)	Weight (gr)	Order Code
TB5	4P - 35A (Single)	1700	3024385
	4P - 70A (Double)	2950	3024386
	4P - 105A (Triple)	4450	3024387
	5P - 35A (Single)	1900	3024376
	5P - 70A (Double)	3250	3024377
	5P - 105A (Triple)	4700	3024378

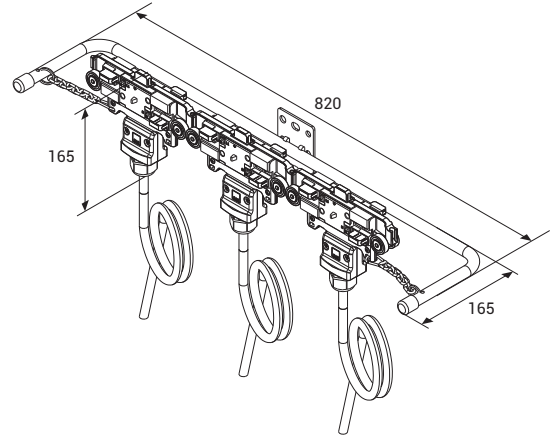

Model	Brushes Number-Current (A)	Weight (gr)	Order Code
TB5	4P - 60A (Single)	2000	3203193
	4P - 120A (Double)	3550	3269558
	5P - 60A (Single)	2200	3203194
	5P - 120A (Double)	3850	3269559

## TB5 Current Collectors With Clip

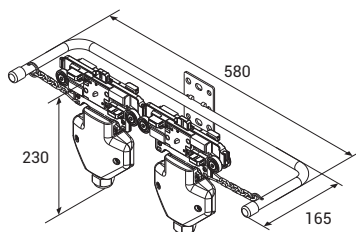
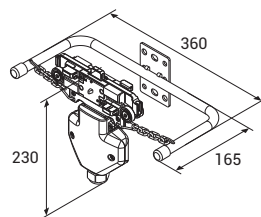
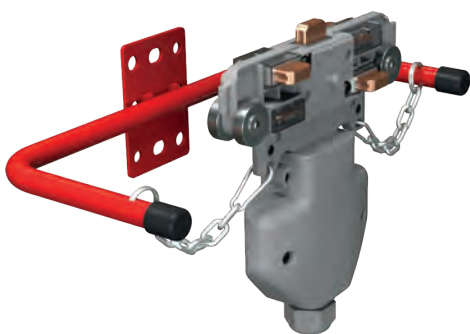

Model	Brushes Number-Current (A)	Weight (gr)	Order Code
TB5	4P - 35A (Single)	1350	3024388
	4P - 70A (Double)	2050	3024389
	4P - 105A (Triple)	3050	3024390
	5P - 35A (Single)	1350	3024379
	5P - 70A (Double)	2250	3024380
	5P - 105A (Triple)	3200	3024381

\*Produced with standard M40 cable gland and 4mm<sup>2</sup> clip.

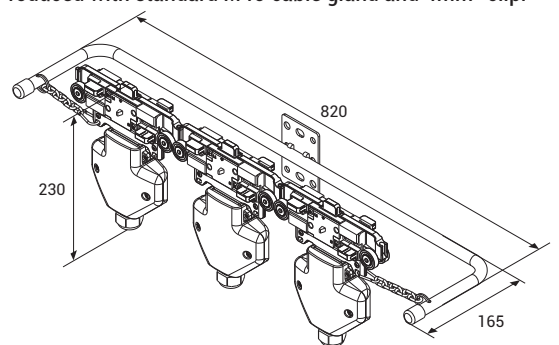

Current collector with clips allow the customers to perform cabling as they desire with the clips they include.

Current collector are the moving elements of the trolley busbar systems. Current collector brushes rub against the conductors and draw continuous current while they move through the busbar line. They adapt to shaky and vibrant conditions thanks to the moving brushes. As current collecting and transfer systems are included in the C-PVC housing, they are protected against human contact.

# E-LINE TBX-S



## TB5 Current Collector With Fuse Box

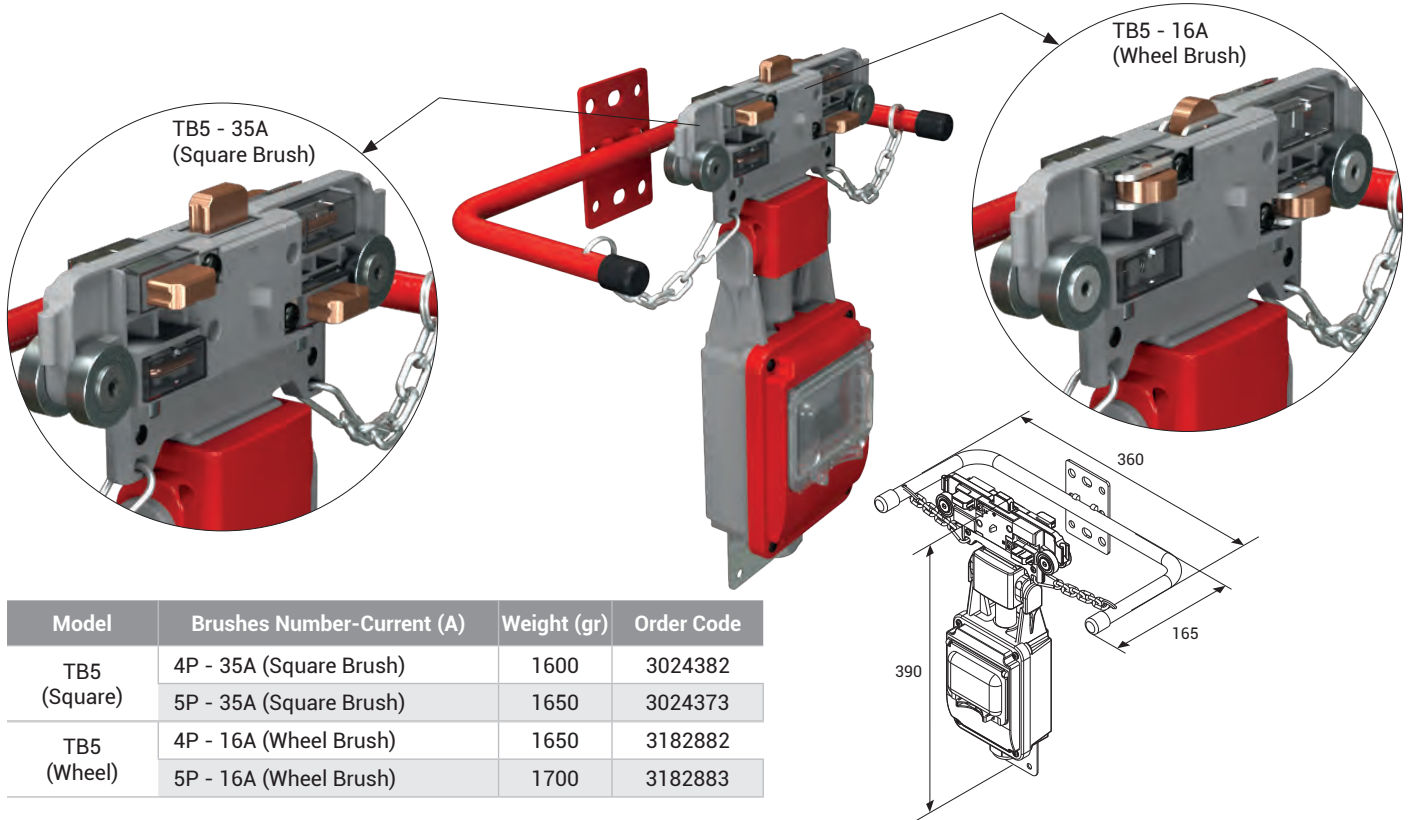

TBX-S

Model	Brushes Number-Current (A)	Weight (gr)	Order Code
TB5 (Square)	4P - 35A (Square Brush)	1600	3024382
	5P - 35A (Square Brush)	1650	3024373
TB5 (Wheel)	4P - 16A (Wheel Brush)	1650	3182882
	5P - 16A (Wheel Brush)	1700	3182883

Fuse boxed with both staff and current receiving area carts current machine's safety can be raised to a higher level. In addition, when it is desired to cut the power of one of the machines on a line, the current is cut off through the fuse, other machines on the line can continue to operate.

Current collector with Wheel Brush simplify the movement of the current collectors inside the busbar by reducing the time at the installation tables when movement is provided by the personnel.

TB5 Current collector models operating speed is max. 100m/min.

## TB5 Current Collector Brushes

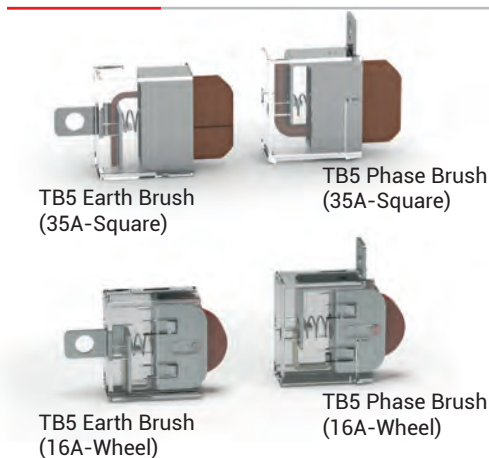

Description	Weight (gr)	Order Code
TB5 Phase Brush (35A-Square)	40	3024371
TB5 Earth Brush (35A-Square)	40	3024372
TB5 Phase Brush (16A-Wheel)	40	3165078
TB5 Earth Brush (16A-Wheel)	40	3165080

## TBX Trolley Transfer Tool

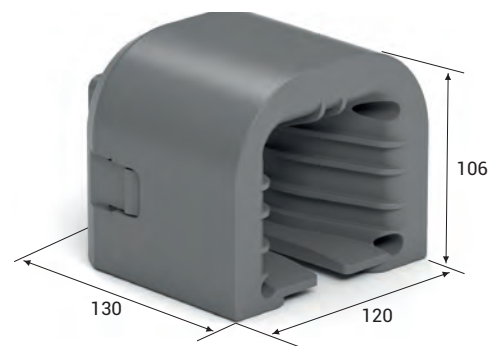

Description	Weight (gr)	Order Code
TBX Trolley Transfer Tool	250	3179529

# E-LINE TBX-S



## TB5 Plastic Sliding Hanger

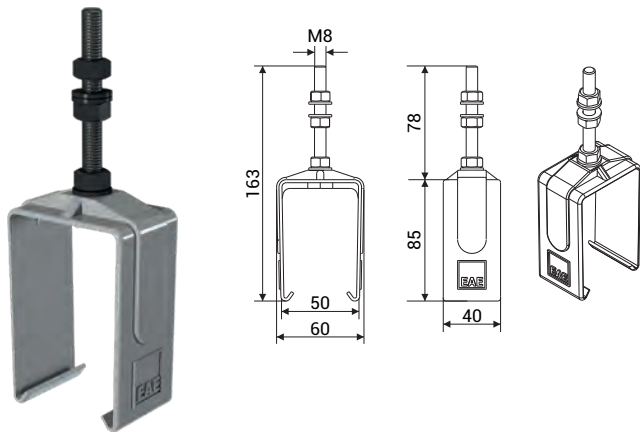

## TB5 Steel Sliding Hanger

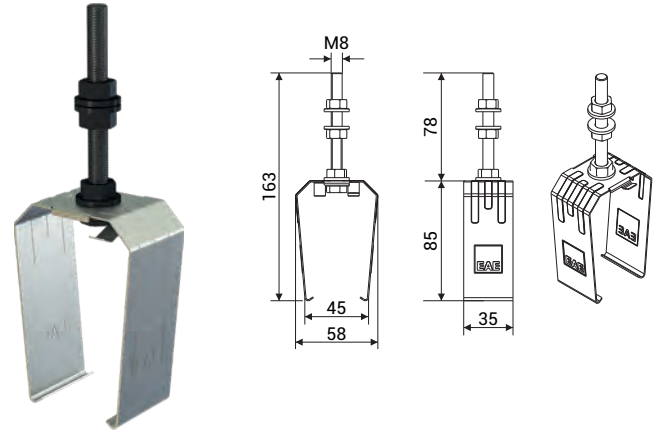

Trolley busbar should be mounted with sliding hangers and each hangers should be between 1,30m - 1,50m. Distance between sliding hanger and other units (joint unit, feeder etc.) should be minimum 300mm.

Description	Weight (gr)	Order Code
TB5 Plastic Sliding Hanger	85	1003664

Description	Weight (gr)	Order Code
TB5 Steel Sliding Hanger	100	1005954

## TB5 Hanger Bracket

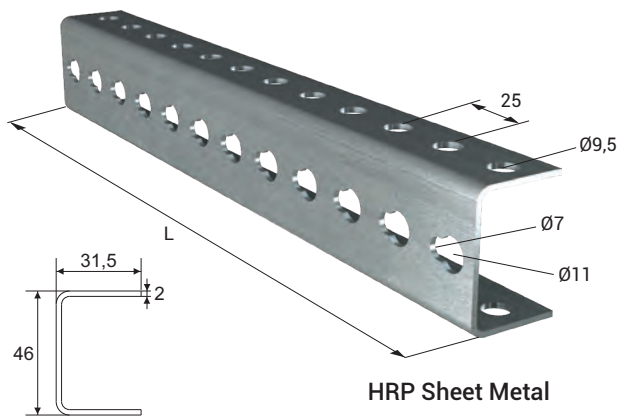

HRP Sheet Metal

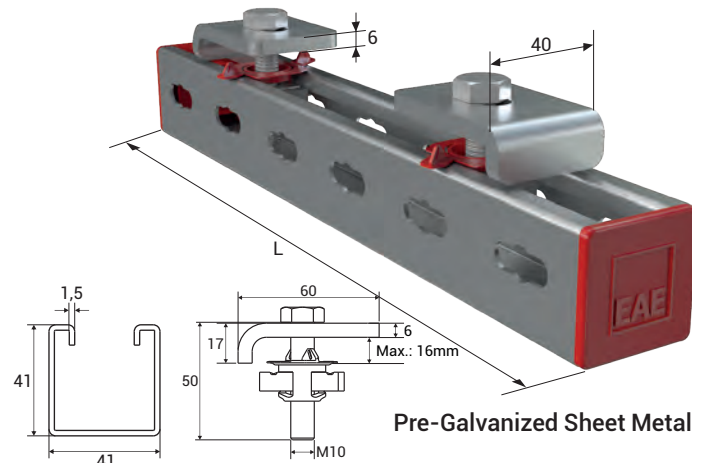

Pre-Galvanized Sheet Metal

Description	L (mm)	Weight (gr)	Order Code
TB Hanger Bracket	250	350	3025153
URC-C/S Hanger Bracket	500	700	3034560
URC-A Hanger Bracket	750	1050	3025382

Description	L (mm)	Weight (gr)	Order Code
TB BR Hanger Bracket Set	300	800	3178916
URC-C/S BR Hanger Bracket Set	600	1250	3178917
URC-A BR Hanger Bracket Set	800	1550	3178918

• Please browse the MFIX catalog to see our various support solutions.

## TBX Extension Element

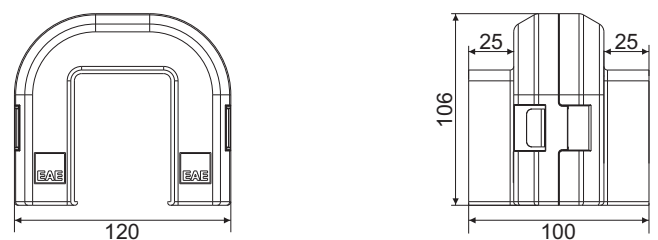

When the busbar line needs to be extended, you may remove the End Closure and install the joint unit to extend.

Description	Weight (gr)	Order Code
TBX Extension Element	280	3136703

# E-LINE TBX-S



## TB5 Current Collector Brushes

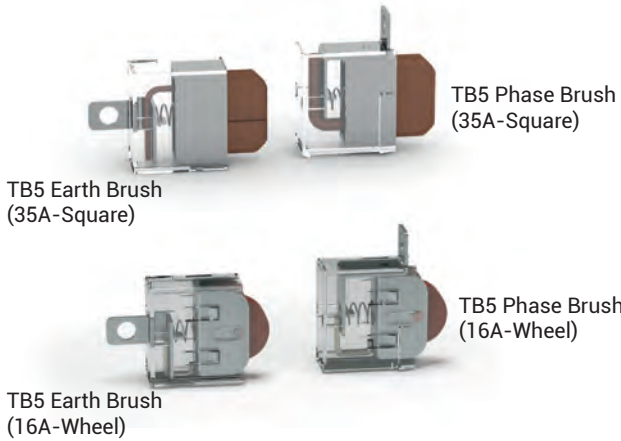

Description	Weight (gr)	Order Code
TB5 Phase Brush (35A-Square)	40	3024371
TB5 Earth Brush (35A-Square)	40	3024372
TB5 Phase Brush (16A-Wheel)	40	3165078
TB5 Earth Brush (16A-Wheel)	40	3165080

## TB5 Copper Conductors



Description (mm x mm)	Order Code
TB5 0.80x16,00 (TB5 Copper)	1003097
TB5 1.00x16,00 (TB5 Copper - 75A)	1002254
TB5 1.50x16,00 (TB5 Copper - 105A)	1002275
TB5 2.00x16,00 (TB5 Copper - 130A)	1003094

## TB Conductor Cassette



Conductor cassette shall be used to prevent damage to the conductors while the copper conductors are installed on the busbar.

Description	Weight (gr)	Order Code
TB Conductor Cassette	6800	3025151

## TB5 Conductor Mounting Tool



Description	Weight (gr)	Order Code
TB5 Conductor Mounting Tool	215	3024456

## TBX Gasket

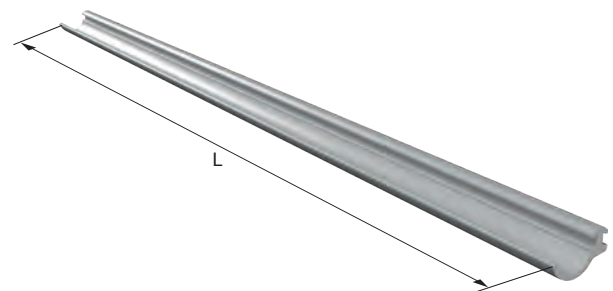

- Continuous length is maximum 300 meters.
- Gasket should be ordered twice the line length.

Description	Weight (gr/m)	Order Code
TBX Gasket Roll (m)	30	1037761

Description	L (mm)	Weight (gr)	Order Code
TBX Gasket Straight Length (Pcs.)	4000	120	1037762

## Voltage Drop

The voltage drop in the busbar lines shall be inspected as per the busbar type selected according to the total current calculated based on the ambient temperature and operating period of the system. Maximum acceptable value for voltage drop is 3%.

### For Direct Current

$$\Delta U = 2 \cdot L_t \cdot I_G \cdot R$$

$\Delta U$  = Voltage Drop [V]

### For Mono-Phase Alternative Current

$$\Delta U = 2 \cdot L_t \cdot I_G \cdot Z$$

$I_G$  = Total current [A]

$R$  = Resistance of the busbar [ $\Omega/m$ ]

### For Three-Phase Alternative Current

$$\Delta U = \sqrt{3} \cdot L_t \cdot I_G \cdot Z$$

$Z$  = Impedance of the busbar [ $\Omega/m$ ]

$L_t$  = Calculated Hole Length [m]

**Note :** Calculation of the current drawn during first start in various motor types;

$I_A$  = Total current drawn in the first start of the motors [A]

For the starting current; Three-phase asynchronous drive in direct start

$I_A$  =  $I_G$  x calculated as 5 to 6

Slip ring rotor motor

$I_A$  =  $I_G$  x calculated as 2 to 3

Frequency converter

$I_A$  =  $I_G$  x 1,20 to 1,50 calculated between.

## Calculation Of Feeding Points

When we take  $L_t$  as the length of the line, feeding points may be selected as shown in the diagrams below to keep the L voltage drop at minimum and it may be used as the hole length for the calculation of  $L_t$  voltage drop.



1 feeding point from the start,  $L_t=L$

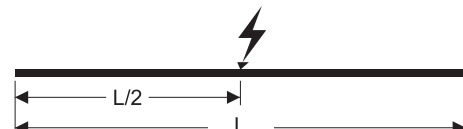

1 feeding point from the center,  $L_t=L/2$



2 feeding points from the start points,  $L_t=L/4$



2 feeding points,  $L_t=L/6$

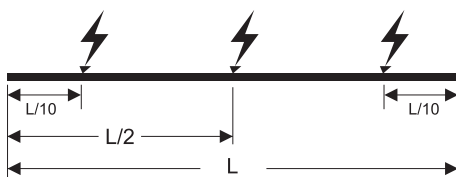

3 feeding points,  $L_t=L/10$

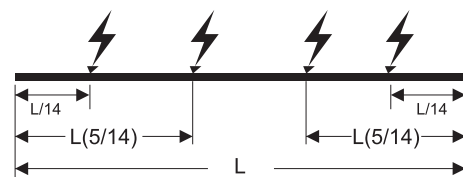

4 feeding points,  $L_t=L/14$

# E-LINE TBX-S

## Installation Manual

### TBX-S - Installation Of Joint Unit

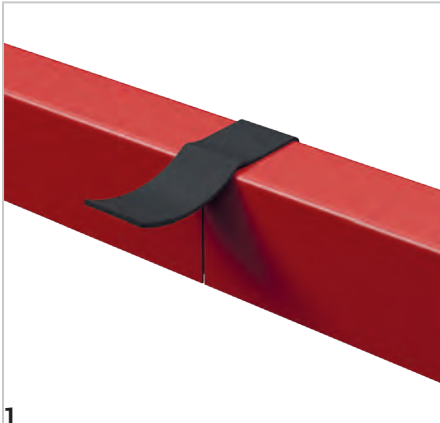

1 The joint point is covered using a self-adhesive EPDM gasket.

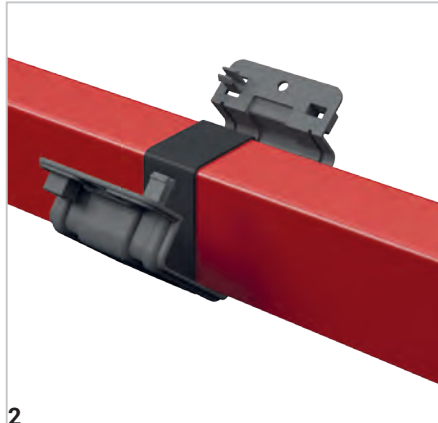

2 Engage the joint unit to the bottom of the busbar and close it.

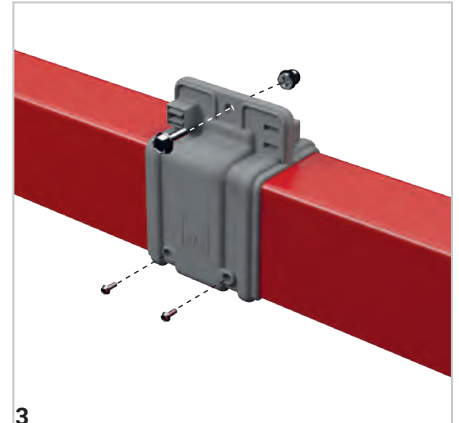

3 Secure it to the housing with screws.

### TBX-S - Feeder Unit

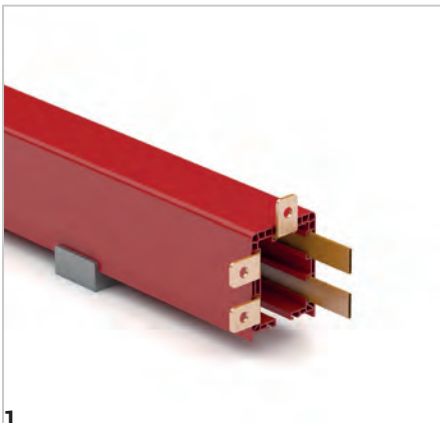

1 Conductors are bend 90° and pushed into the housing.

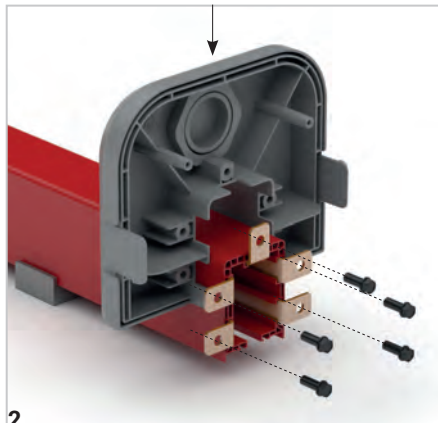

2 Housing and screw them to the feeding module.

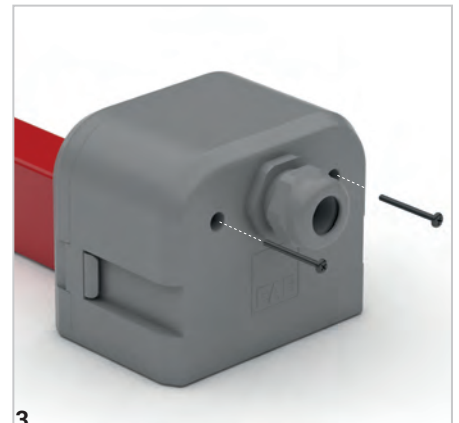

3 Close the module cover and screw it.

### TBX-S - Line Feed Unit - 2 (Jointed Type)

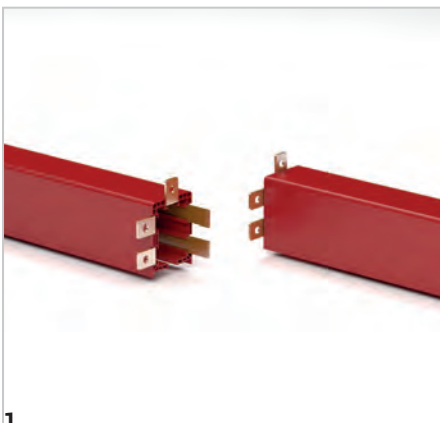

1 Conductors are bend 90 ° and pushed into the housing. The two housing are combined in such a way that the bent conductors remain in the notched area.

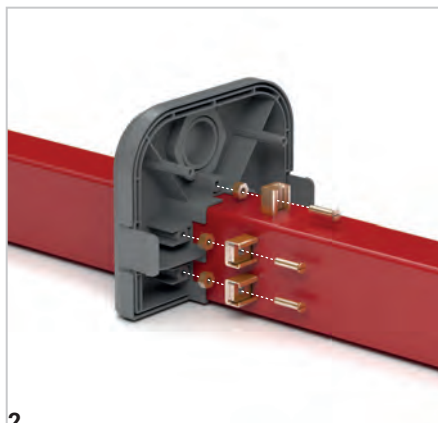

2 Conductors are brought back to back and combined with clips. Supply cables are connected to clips.

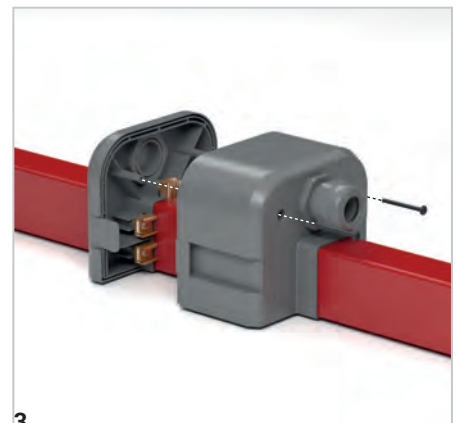

3 Close the module cover and screw it.

# E-LINE TBX-S

## Installation Manual

### TBX-S - Line Feed Unit - 1 (Continuous Type)

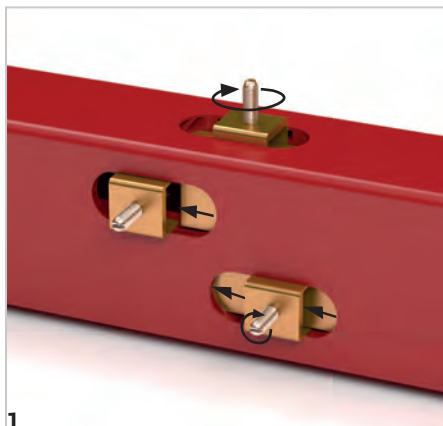

1 Put the conductors through the clips and screw them.

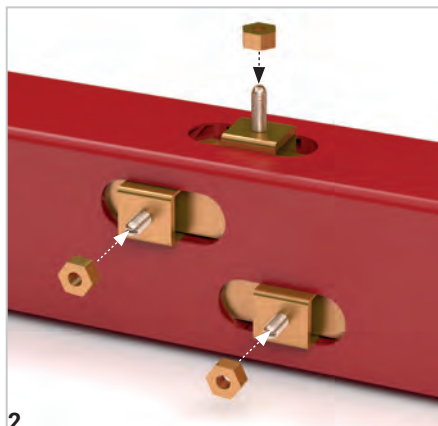

2 Connect the feeding cables to the clips with nuts.

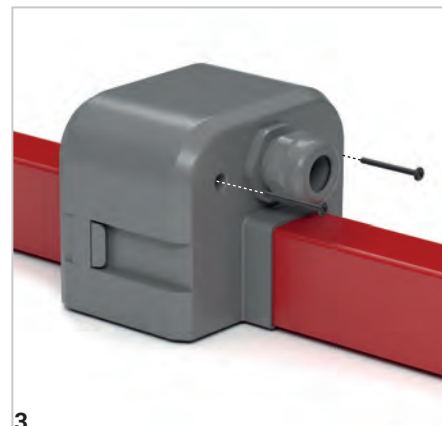

3 Close the module cover and screw it.

### TBX-S - End Closure

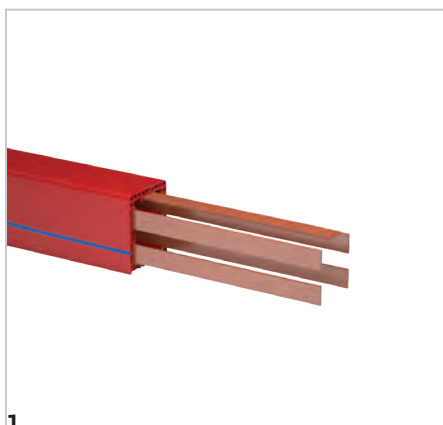

1 Cut the coppers at the end of the line by leaving a extra length of 15 cm.

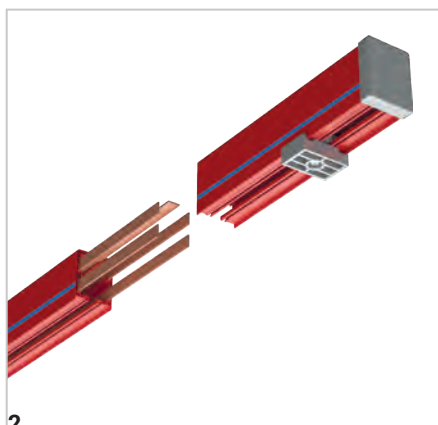

2 After placing the current collector to the system, place the End Closure so that it shall house the coppers.

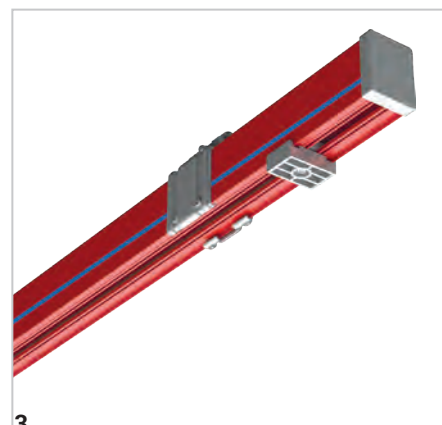

3 Install it on the system as you do while installing the extension.

### TBX-S - Conductor Mounting Tool

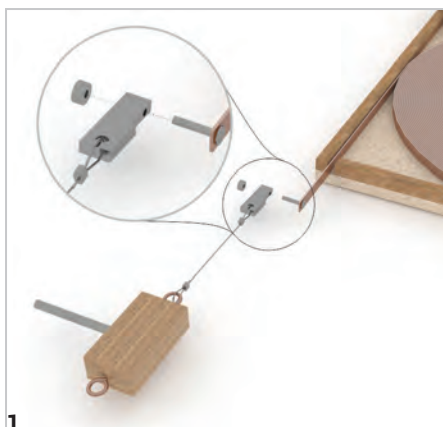

1 Screw the conductor to the conductor mounting tool.

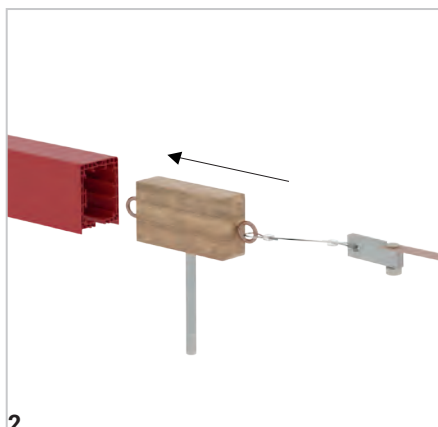

2 Drive the conductor mounting tool along the line.

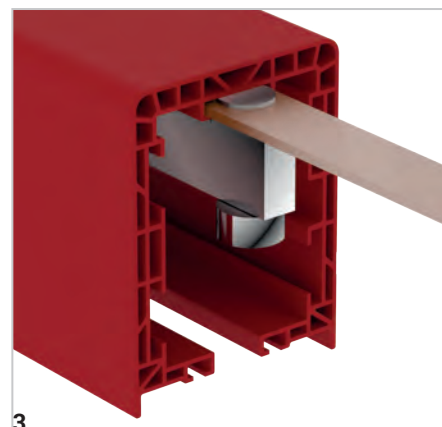

3 Ensure that the conductor is seated.

# E-LINE TBX-S

## Offer Request Form



Date :

Project Name	:	<input type="text"/>
Company	:	<input type="text"/>
Name Surname	:	<input type="text"/>
Tel	:	<input type="text"/>
E-Mail	:	<input type="text"/>
Address	:	<input type="text"/>

### General Data

Track Length	:	<input type="text"/>
Number of Cranes on Track	:	<input type="text"/>
Crane Travel Speed	:	<input type="text"/>

### Environmental Data

Operating Environment	:	<input type="checkbox"/> Indoor	<input type="checkbox"/> Outdoor
Ambient Temperature	:	<input type="text"/> °C min.	<input type="text"/> °C max.
Other Operating Conditions (Humidity, Dust, Chemical Influence, etc.)	:	<input type="text"/>	

### Electrical Data

Operating Voltage	:	<input type="text"/> Volts	<input type="checkbox"/> AC	<input type="checkbox"/> DC			
		<input type="text"/> Phases	<input type="checkbox"/> N	<input type="checkbox"/> PE			
Position and Number of Feeder	:	<input type="text"/> from End	<input type="text"/> from Middle				
Duty Cycle (%)	:	<input type="checkbox"/> 50%	<input type="checkbox"/> 60%	<input type="checkbox"/> 70%	<input type="checkbox"/> 80%	<input type="checkbox"/> 90%	<input type="checkbox"/> 100%

Motor Specifications	Crane - 1		Crane - 2		Crane - 3	
	Power (kW)	Current (A)	Power (kW)	Current (A)	Power (kW)	Current (A)
Hoist motors	<input type="text"/>	<input type="text"/>	<input type="text"/>	<input type="text"/>	<input type="text"/>	<input type="text"/>
Auxiliary motor	<input type="text"/>	<input type="text"/>	<input type="text"/>	<input type="text"/>	<input type="text"/>	<input type="text"/>
Long travel	<input type="text"/>	<input type="text"/>	<input type="text"/>	<input type="text"/>	<input type="text"/>	<input type="text"/>
Cross travel	<input type="text"/>	<input type="text"/>	<input type="text"/>	<input type="text"/>	<input type="text"/>	<input type="text"/>

### Options

Brackets Required	:	<input type="checkbox"/> Yes	<input type="checkbox"/> No
Repair Zone Required	:	<input type="checkbox"/> Yes	<input type="checkbox"/> No
Collector Replacement Required:		<input type="checkbox"/> Yes	<input type="checkbox"/> No
		<input type="text"/> Qty	<input type="text"/> Qty
Descriptions	:	<input type="text"/>	

Please duplicate this page for your own use.

## DECLARATION

# CE DECLARATION OF CONFORMITY

**Product Group** E-Line TB Trolley Busbar Systems  
**Manufacturer** Akcaburgaz Mahallesi, 3114. Sokak,  
No:10 34522 Esenyurt-Istanbul

The objects of the declaration described below is in conformity with the relevant Cable gland harmonisation legislation. This declaration of conformity is issued under the sole responsibility of the manufacturer.

**Standard:**

**TS EN 61439-6**

Low-voltage switchgear and controlgear assemblies - Part 6: Busbar trunking systems

**CE - Directive:**

2014/35/EU "The Low Voltage Directive"

2014/30/EU "(EMC) Electromagnetic Compatibility Directive"

2011/65/EU "RoHS Directive"

**Technical Document Preparation Official:**

EAE Elektrik Asansor End. Insaat San. Tic. A.S.  
Akcaburgaz Mahallesi, 3114. Sokak, No:10 34522 Esenyurt-Istanbul

Mustafa AKÇELİK

**Date**

20.03.2026

**Document Authorized Signatory**

Elif Gamze KAYA OK  
Deputy General Manager



# SUSTAINABLE FUTURE

## Sustainability Management at EAE Elektrik



As part of our goal to support sustainable development and green transformation, measuring, evaluating, and managing all economic, environmental, and social impacts resulting from our sustainability practices is a key governance priority for EAE Elektrik. We act with great care in analyzing, monitoring, and managing the economic, environmental, and social impacts and risks that arise throughout our value chain in both our national and global operations.

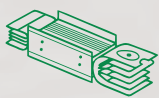

Busbar Systems

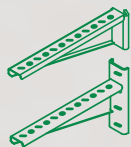

Support Systems

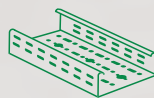

Cable Tray Systems

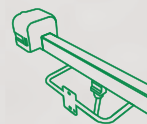

Trolley Busbar Systems



Fit-Out Solutions

*"We are working together with all our stakeholders to develop the electrical technologies that will build the future."*

You can visit our sustainability website at [sustainability.eaeelectric.com](https://sustainability.eaeelectric.com)



#FutureTogether

**EAE Elektrik**  
**Head Office**

Akcaburgaz Mahallesi,  
3114. Sokak, No: 10 34522  
Esenyurt - Istanbul - Turkiye  
Tel: +90 (212) 866 20 00  
Fax: +90 (212) 886 24 20

**EAE DL 4 Factory**  
**Busbar 2**

Organize Sanayi Bolgesi Mahallesi,  
6. Cadde, No: 14/10, 41455  
Dilovasi - Kocaeli - Turkiye  
Tel: +90 (262) 999 05 55  
Fax: +90 (262) 502 01 45



Please visit our website for the updated  
version of our catalogues.  
[www.eaelectric.com](http://www.eaelectric.com)



Catalogue 08 - En. / Rev. 16 0 Pcs. 25/05/2026  
E.U.

EAE has full right to make any revisions or changes on this catalogue without any prior notice.