



DABLINE

Underfloor Busbar Systems (63-80A)

EAE GROUP IN NUMBERS



Since 1973

EAE Group of Companies started its journey in the electrical sector in 1973 with the establishment of EAE Elektrik. Since its founding, EAE has grown rapidly, expanding its production and areas of operation by incorporating EAE Lighting in 1983, EAE Machinery in 1996, EAE Electrotechnics in 2004, and EAE Technology in 2009.

EAE carries out its production activities in accordance with ISO 9001 Quality Management, ISO 14001 Environmental Management, ISO 14064-1 Greenhouse Gas Management System, ISO 45001 Occupational Health and Safety Management, ISO 10002 Customer Satisfaction Management, ISO 50001 Energy Management System, and ISO 27001 Information Security Management System standards.



50+
Years Experience



8
Active Factories



370.000m²
Enclosed Space



3
R&D Centers



150+
Countries Exported To

CONTENTS

Introduction	2
Technical Characteristics	4
Order Code System & Conductor Configuration	5
Standard Straight Length	6
Feeder Boxes & Elbows	7
Tap Off Plugs	8
Tap Off Boxes	9
Joint Installation	10
Plug Installation	11
Feeder Box Installation	12
System Manual	13
Floor "U" Support Installation Manual	14
Application Area & Advantages	15
Product Overview	16
CE Declaration	17
Certificates	18

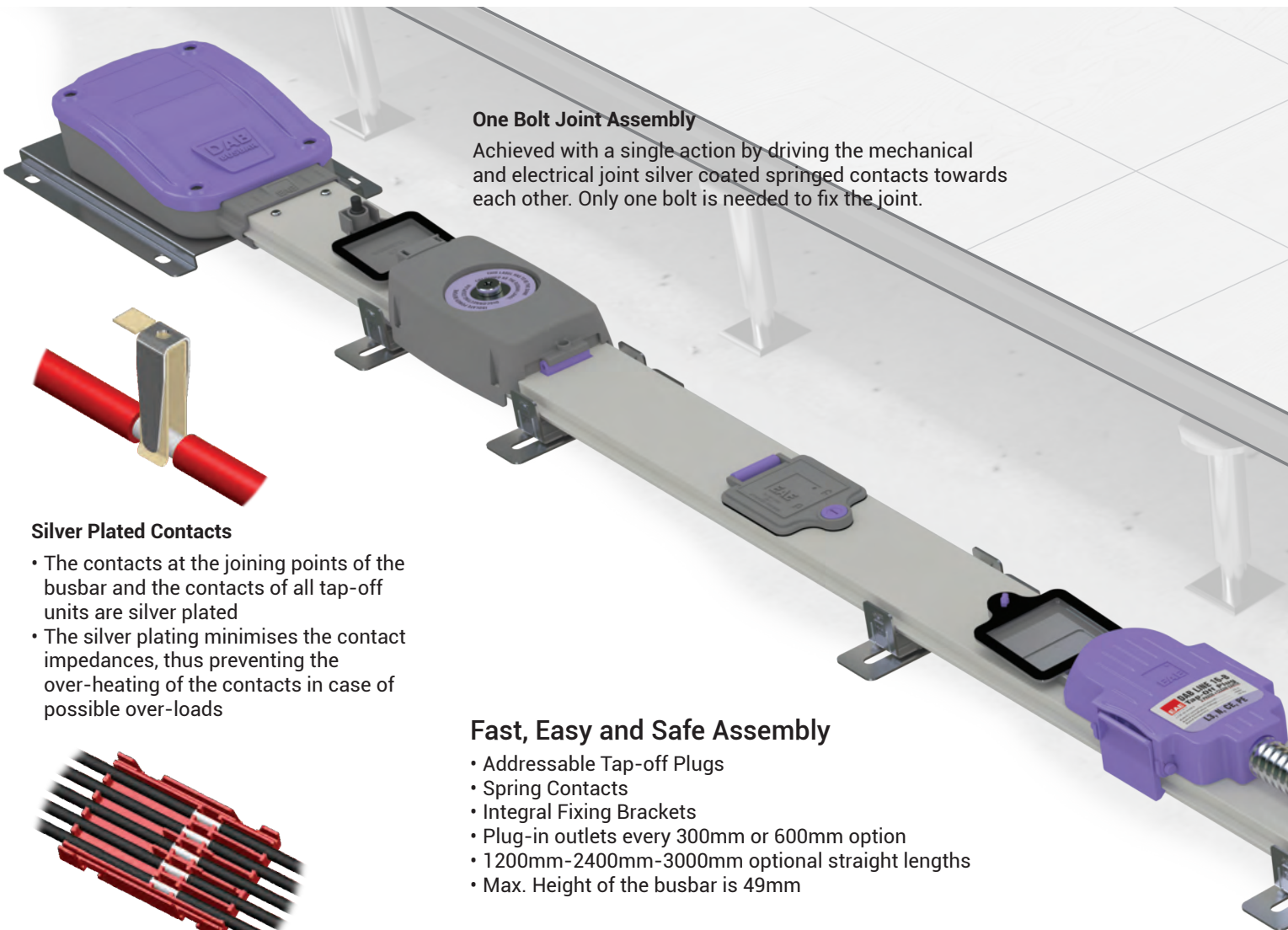

One Bolt Joint Assembly

Achieved with a single action by driving the mechanical and electrical joint silver coated spring coated contacts towards each other. Only one bolt is needed to fix the joint.

Silver Plated Contacts

- The contacts at the joining points of the busbar and the contacts of all tap-off units are silver plated
- The silver plating minimises the contact impedances, thus preventing the over-heating of the contacts in case of possible over-loads

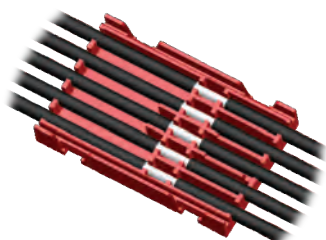

Fast, Easy and Safe Assembly

- Addressable Tap-off Plugs
- Spring Contacts
- Integral Fixing Brackets
- Plug-in outlets every 300mm or 600mm option
- 1200mm-2400mm-3000mm optional straight lengths
- Max. Height of the busbar is 49mm

Tin Plated Conductors

The formation of Copper Oxide is prevented by tin plating the full length of the electrolytic copper conductors. With this process, contact resistances are minimised. The contacts of the tap-off plugs grip the busbar conductors on two surfaces

Maximum Safety

- IP55 Protection Degree
- Single Bolt joints
- Electrical Joints are Silver Plated
- Fully insulated conductors
- Halogen Free plastics up to 960 °C Fire rating
- Keyed Tap-off Plugs
- Different colours for different type busbars

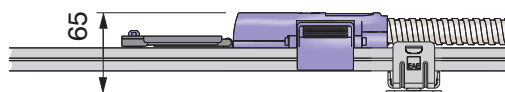
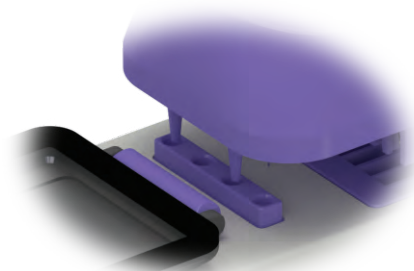

Maximum height 65 mm

Can be used in 65mm floor voids

Coded Tap-off Plugs

Arrangement of DABLINE Busbar Systems are designed with different pins to prevent incorrect assembly

Performance

- Tested according to IEC 61439-6
- Rated up to 80A
- Up to 32A plugs available
- Optional plugs with MCB
- Housing is painted galvanised sheet steel
- High corrosion resistance
- 4 conductors (L1/L2/L3/N/PE (Housing))
- 5 conductors + PE (Housing)(L1/L2/L3/N/CE/PE (Housing))
- Tin plated electrolytic copper conductors
- Plastic Housing Feeder Box

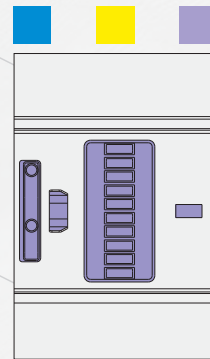

Colour Coded

Each busbar type has a different colour code

Support System

Each busbar length is complete with integral floor fixing brackets.

IP55 Plug-in Outlets

Plug-in outlets have IP55 protection covers with EPDM type gaskets

Rated Current	In	A	63	80
Busbar Code			06	08
Main Standards	IEC 61439-6:2012 Ed.1 ; IEC 61439-1 Ed.2:2011, TS EN 61439-1: 2011			
Rated Isolation Voltage	Ui	V	690	690
Rated Operational Voltage	Ue	V	690	690
Rated Frequency	f	Hz	50	50
Pollution Degree	3			
Protection Degree	Ip55	55		
External Mechanical Impacts (IK Code)*	IK07			
Protection for Safety	Basic Protection (HD 60364-4-41, Clause A1)			
Rated Conditional Short Circuit Current	I _{cc}	kA	16	16
Mechanical Data				
Number of Conductor			3 to 5	3 to 5
Conductor Cross-section		mm ²	8	12,6
Housing Cross-section (Cu equivalent)		mm ²	13	13
Cable Terminal Capacity		mm ²	16	16
Cable Section of 32A Plug		mm ²	4	4
Cable Section of 13A Plug with Fuse		mm ²	1,5 / 2,5	1,5 / 2,5
Flexible Corner Element Cable		mm ²	16	16
Flexible Corner Conduit		mmØ	25	25
Busbar Weight - for 5 conductor		kg/m	1,46	1,57
Material Facility				
Housing			Painted Galvanised Steel	
Busbar Conductor			High Conductivity Copper	
Busbar Isolators			PPx-FR (according to RoHS and REACH standards)	
Busbar Connection / Plug / Feeder Connections			PPx-FR (according to RoHS and REACH standards)	
Socket Outlet Entry Shutters			PPx-FR (according to RoHS and REACH standards)	
Plug Body			PPx-FR (according to RoHS and REACH standards)	
Busbar Cable Connections			Copper	
Plug Connections			Copper	
Plug / Flexible Corner Conduit (Metal)			Galvanised Steel	
Plug (Cable)			LSOH - BS EN 50525-3-41 / TS EN 50525-3-31	
Flexible Corner Connection Cable		mm ²	16	16
Feeder Module / Flexible Connection Box			PPx-FR (according to RoHS and REACH standards)	
Feeder Module Connection Terminal / Earthing Terminal			Brass	
Busbar Fixing Element			Galvanised Steel	
Mean Phase Conductor Characteristics at Rated Current In				
Resistance at a conductor temperature of 20 °C	R ₂₀	mΩ/m	2,293	1,483
Resistance at an ambient air temperature of 35 °C	R	mΩ/m	3,063	1,981
Reactance (Independent from Temperature)	X	mΩ/m	0,422	0,273
Positive and negative sequence impedances at an ambient air temperature of 35°C	Z	mΩ/m	3,092	2,000
Positive and negative sequence impedances at a conductor temperature of 20°C	Z ₂₀	mΩ/m	2,331	1,507
Mean Fault-Loop Characteristics				
Zero-sequence Impedance				
Zero-sequence impedance at a conductor temperature of 20°C	Z _{(0)b20pH} N	mΩ/m	10,125	6,702
Zero-sequence impedance at a conductor temperature of 20°C	Z _{(0)b20pH} PE	mΩ/m	8,951	8,676
Zero-sequence impedance at a conductor temperature of 20°C	Z _{(0)b20pH} CPE	mΩ/m	10,619	6,630
Zero-sequence impedance at an ambient air temperature of 35°C	Z _{(0)bph} N	mΩ/m	13,481	8,883
Zero-sequence impedance at an ambient air temperature of 35°C	Z _{(0)bph} PE	mΩ/m	11,804	11,466
Zero-sequence impedance at an ambient air temperature of 35°C	Z _{(0)bph} CPE	mΩ/m	14,092	8,793
Resistances and Reactances				
Resistance at a conductor temperature of 20 °C	R _{b20pHph}	mΩ/m	4,846	3,151
Resistance at a conductor temperature of 20 °C	R _{b20pH} N	mΩ/m	4,830	3,181
Resistance at a conductor temperature of 20 °C	R _{b20pH} PE	mΩ/m	4,865	4,158
Resistance at a conductor temperature of 20 °C	R _{b20pH} CPE	mΩ/m	4,987	3,206
Resistance at an ambient air temperature of 35 °C	R _{bphph}	mΩ/m	6,475	4,210
Resistance at an ambient air temperature of 35 °C	R _{bph} N	mΩ/m	6,454	4,251
Resistance at an ambient air temperature of 35 °C	R _{bph} PE	mΩ/m	6,501	5,556
Resistance at an ambient air temperature of 35 °C	R _{bph} CPE	mΩ/m	6,664	4,285
Reactance (Independent from temperature)	X _{bphph}	mΩ/m	0,477	0,380
Reactance (Independent from temperature)	X _{bph} N	mΩ/m	0,500	0,531
Reactance (Independent from temperature)	X _{bph} PE	mΩ/m	1,098	1,128
Reactance (Independent from temperature)	X _{bph} CPE	mΩ/m	0,729	0,517

- All phase conductor characteristics had been determined according to Annex BB of IEC 61439-6.
- Fault-loop zero-sequences impedances had been determined according to Annex CC of IEC 61439-6.
- Fault-loop resistances and reactances had been determined according to Annex DD of IEC 61439-6.

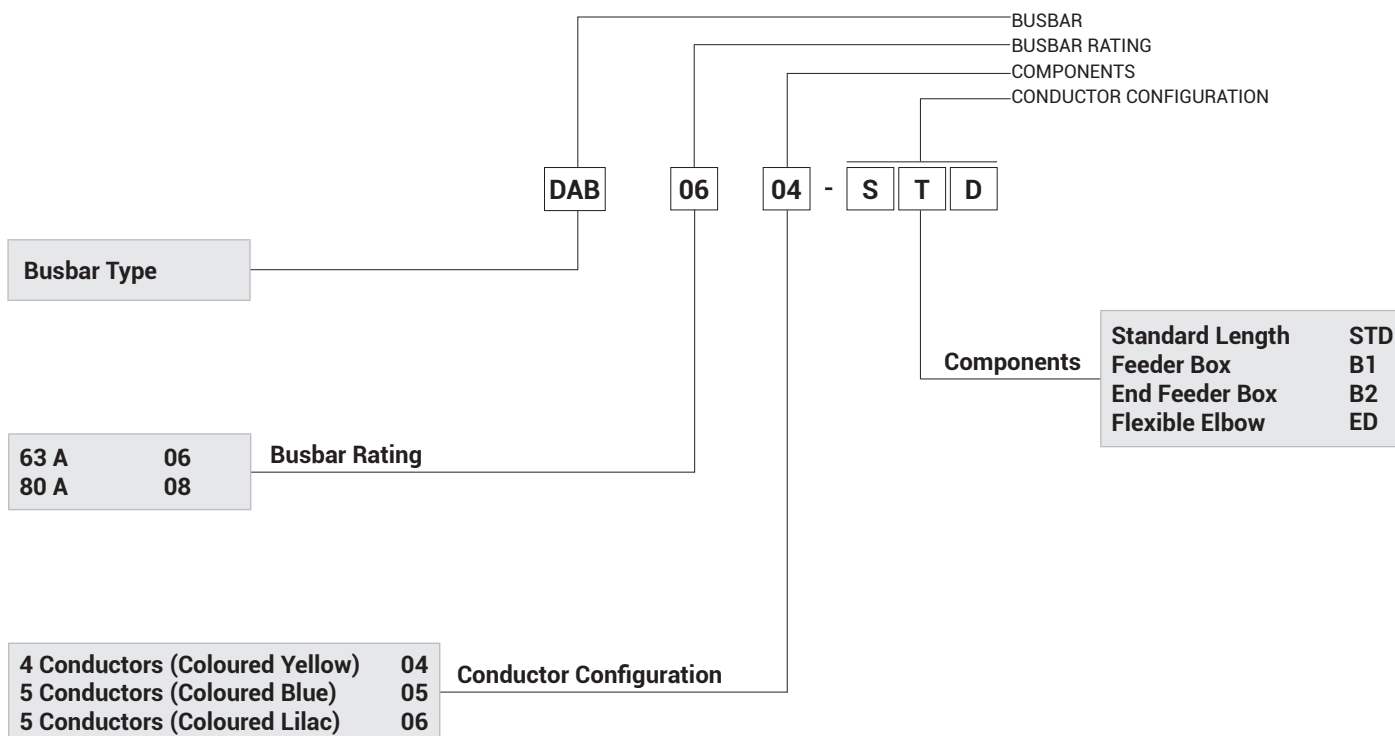

Conductor Configuration

Coloured Yellow - 04

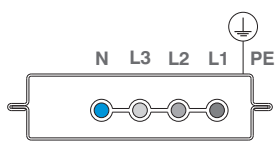

3L+N+PE(Housing)
3 Phase System

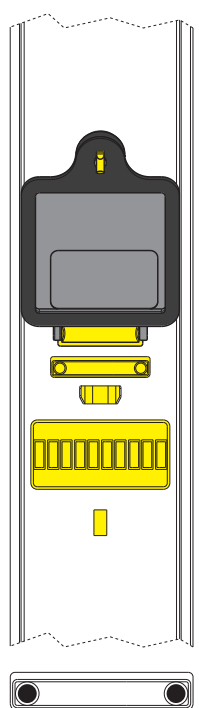

Addressable Pins

Coloured Blue - 05

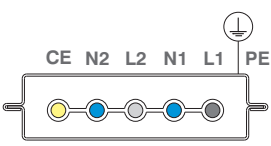

2L+2N+CE+PE(Housing)
Dual Circuit Busbar

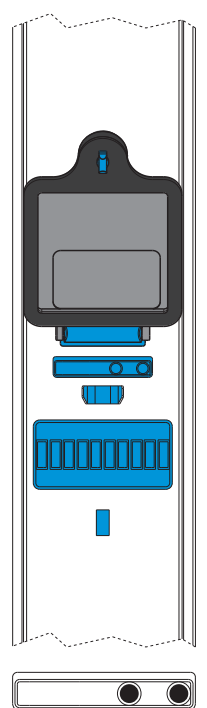

Addressable Pins

Coloured Lilac - 06

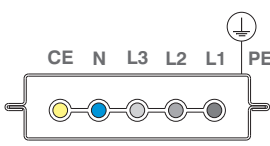

3L+N+CE+PE(Housing)
3 Phase / Clean Earth

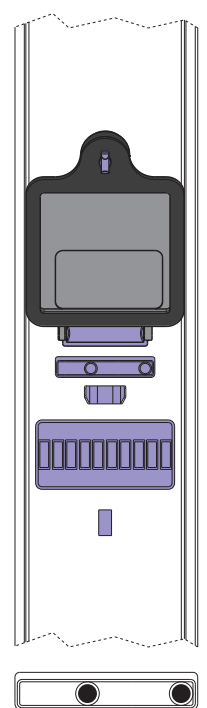

Addressable Pins

Description	Busbar Length (mm)					
	1200		2400		3000	
	Number of Plug-in Points (pc)					
	2	3	4	7	5	9
DAB 0604 - STD Coloured Yellow	3066743	3066744	3066745	3066746	3066747	3066748
DAB 0605 - STD Coloured Blue	3066749	3066750	3066751	3066752	3066753	3066754
DAB 0606 - STD Coloured Lilac	3066755	3066756	3066757	3066758	3066759	3066760

Busbar Systems (80A)

Description	Busbar Length (mm)					
	1200		2400		3000	
	Number of Plug-in Points (pc)					
	2	3	4	7	5	9
DAB 0804 - STD Coloured Yellow	3066773	3066774	3066775	3066776	3066777	3066778
DAB 0805 - STD Coloured Blue	3066779	3066780	3066781	3066782	3066783	3066784
DAB 0806 - STD Coloured Lilac	3066785	3066786	3066787	3066788	3066789	3066790

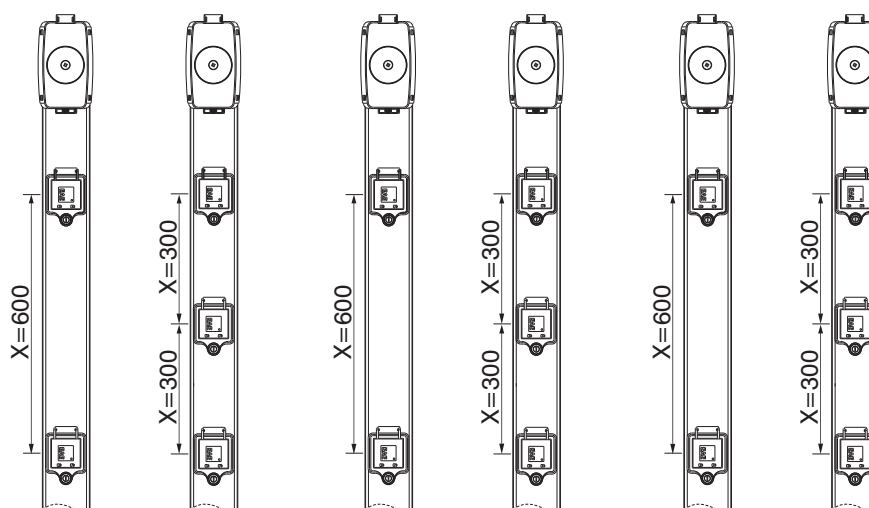

X=Distance between plug-in outlets

Adjustable Fixing Bracket

3 pcs supplied on 1200mm straight length
 5 pcs supplied on 2400mm straight length
 6 pcs supplied on 3000mm straight length

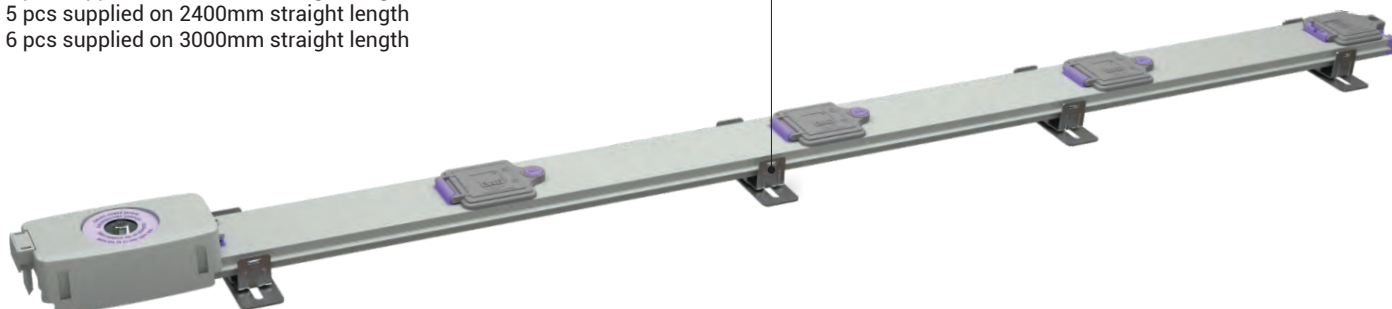

B1 - Feeder Box		Code	
Description		(63A)	(80A)
B1 Coloured Yellow	3L+N+PE (Housing)	3066793	3066813
B1 Coloured Blue	2L+2N+CE+PE (Housing)	3066794	3066814
B1 Coloured Lilac	3L+N+CE+PE (Housing)	3066795	3066815

Attention!

(*) The Feeder Box and Flexible Elbow modules must be used together with the "U" support.

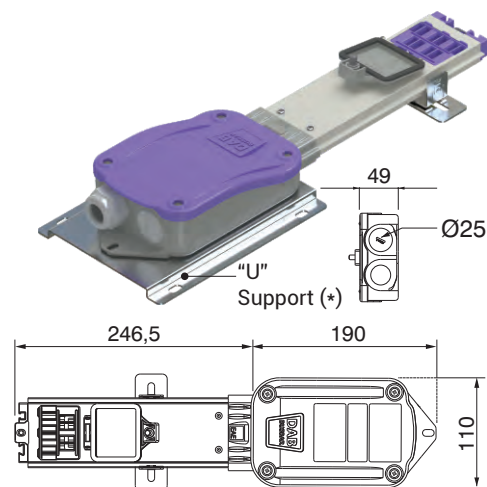

B2 - End Feeder Box		Code	
Description		(63A)	(80A)
B2 Coloured Yellow	3L+N+PE (Housing)	3246703	3246711
B2 Coloured Blue	2L+2N+CE+PE (Housing)	3246704	3246712
B2 Coloured Lilac	3L+N+CE+PE (Housing)	3246705	3246714

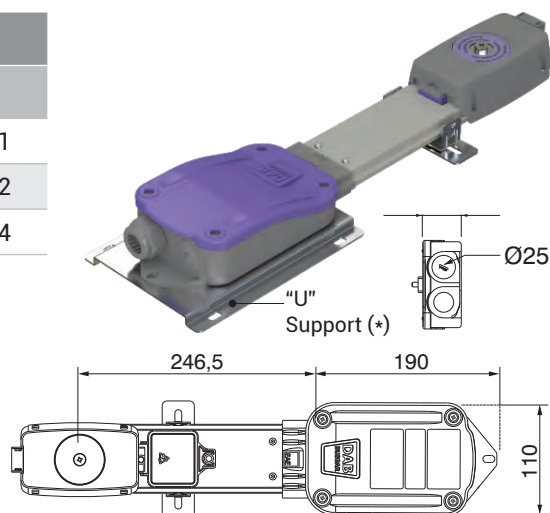

ED - Flexible Elbow

Description	Conduit		Code	
	Steel	Plastic	(63A)	(80A)
ED Coloured Yellow 3L+N+PE(Housing)	✓		3066805	3066825
		✓	3066806	3066826
ED Coloured Blue 2L+2N+CE+PE(Housing)	✓		3066807	3066827
		✓	3066808	3066828
ED Coloured Lilac 3L+N+CE+PE(Housing)	✓		3066809	3066829
		✓	3066810	3066830

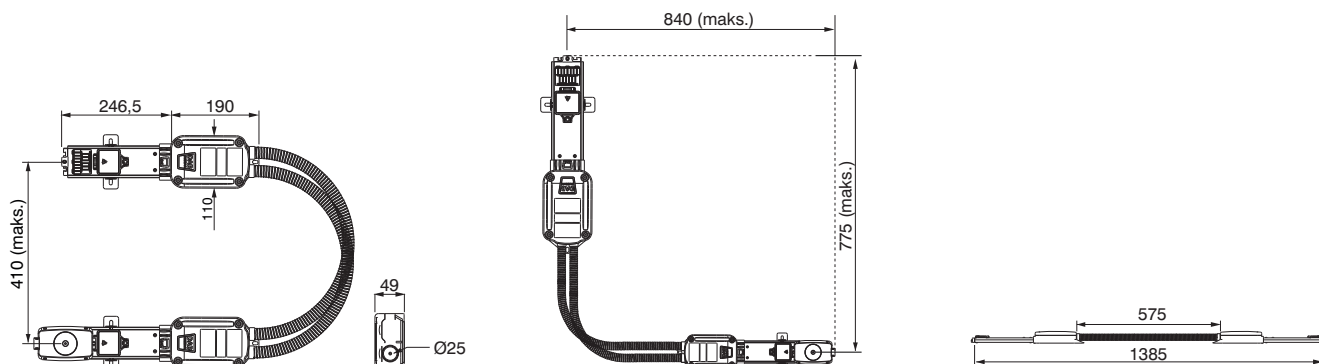
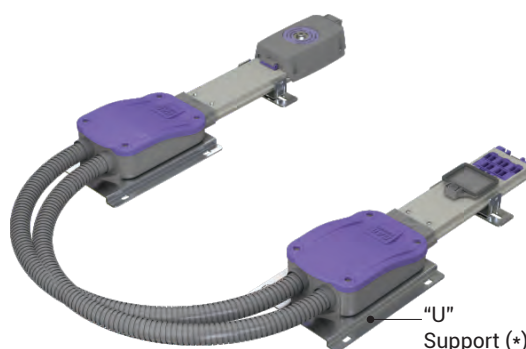

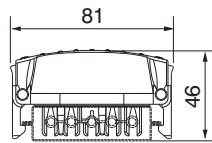
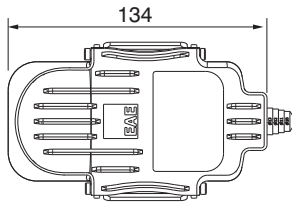

16A Cylindrical Fuse
16A Unfused
32A Unfused

Type	Conductor Configuration ⁽¹⁾	Conduit ⁽²⁾	5m LSF Cable (Cable Section 2,5 mm ²)		Without Cable						
			Unfused	Fused ⁽³⁾	Unfused						
			16A ⁽⁴⁾	16A ⁽⁶⁾	16A ⁽⁶⁾	32A ⁽⁶⁾					
Coloured Yellow 4 conductors	L1	N	PE	-----		3048905	3048906	3048907			
				Steel	3049289						
				Plastic	3049290						
	L2	N	PE	-----		3048908	3048909	3048910			
				Steel	3049291						
				Plastic	3049292						
	L3	N	PE	-----		3048911	3048912	3048913			
				Steel	3049293						
				Plastic	3049294						
	L1	L2	L3	N	PE	-----		3048914	3048915	3048916	
						Steel	3049295				
						Plastic	3049296				
Coloured Blue 5 conductors	L1	N1		PE	-----		3048917	3048918	3048919		
					Steel	3049297					
					Plastic	3049298					
	L2	N	CE	PE	-----		3048920	3048921	3048922		
					Steel	3049299					
					Plastic	3049300					
	L1	N1	L2	N2	CE	PE	-----		3048923	3048924	3048925
						Steel	3049301				
						Plastic	3049302				
	Coloured Lilac 5 conductors	L1		N	CE	PE	-----		3048926	3048927	3048928
							Steel	3049303			
							Plastic	3049304			
L2			N	CE	PE	-----		3048929	3048930	3048931	
						Steel	3049305				
						Plastic	3049306				
L3		N	CE	PE	-----		3048932	3048933	3048934		
						Steel	3049307				
						Plastic	3049308				
L1		L2	L3	N	CE	PE	-----		3048935	3048936	3048937
						Steel	3049309				
						Plastic	3049310				

1- PE = Housing
CE = Isolated Clean Earth
Please call us for non-standard phase sequence.

2- Zinc Plated Steel Conduit
PA6 Halogen Free Plastic Conduit

3- with 16A 8x32 IEC 60269-1,2,3 Cylindrical Fuse

Note: Cylindrical fuse link included.

4- 16A Plug with 2,5mm² Cross Section Cable

5- LSF: Low Smoke&Fume

6- For 16A plug; 2,5mm² connector terminal and Ø16 (mono-phase) and Ø21 (three-phase) fixing hole for cable conduit.
For 32A plug; 4mm² connector terminal and Ø21 fixing hole for cable conduit.

Note: When you supply tap-off plugs without cable and spirals, which it is like used later in construction, you should ground the metal spiral.

DABLINE

Tap Off Boxes

Tap Off Boxes (Unfused and Complete with MCB options)

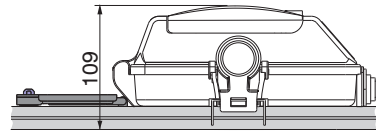
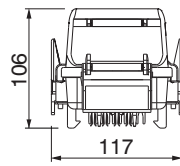
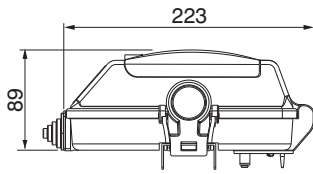

Type	Conductor Configuration ⁽¹⁾						32A ⁽³⁾
							Without Cable
							Unfused ⁽⁶⁾
Coloured Yellow 4 conductors	L1			N		PE	3035924
		L2		N		PE	3035925
			L3	N		PE	3035926
	L1	L2	L3	N		PE	3035927
Coloured Blue 5 conductors	L1	N1				PE	3046701
			L2	N	CE	PE	3046716
	L1	N1	L2	N2	CE	PE	3035928
Coloured Lilac 5 conductors	L1			N	CE	PE	3035984
		L2		N	CE	PE	3035999
			L3	N	CE	PE	3036014
	L1	L2	L3	N	CE	PE	3036285

1- PE = Housing
CE = Isolated Clean Earth
Please call us for non-standard phase sequence.

2- Included DIN rail for MCB mounting.

DABLINE

Joint Coupler Installation

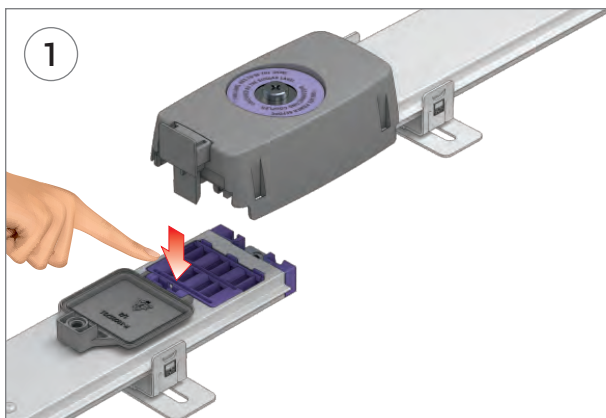

1- To join two busbar lengths as shown in the picture left, the additional module alignment pin should be aligned with the slot in the other window.



2- Push home the Joint Coupler alignment pin into the slot on the other window

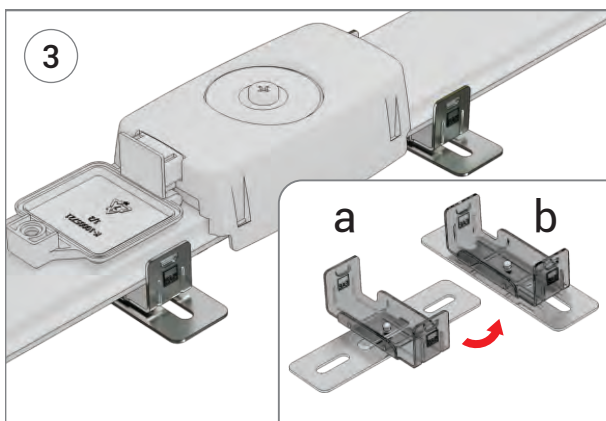

3- Please make sure that adjustable brackets are mounted near to joint points.

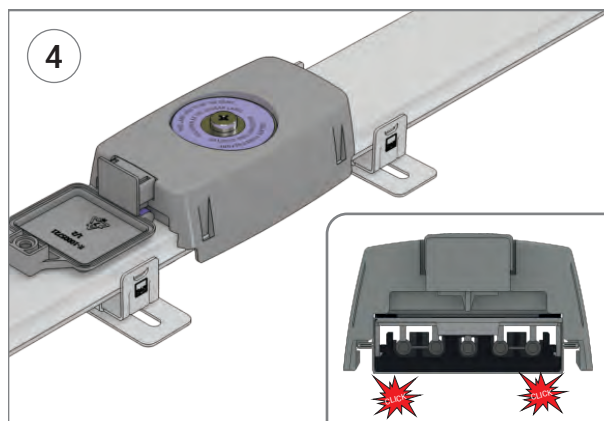

4- Ensure that the Joint Coupler claws, clip over the busbar body. (Joint coupler will not release after being clicked into place)

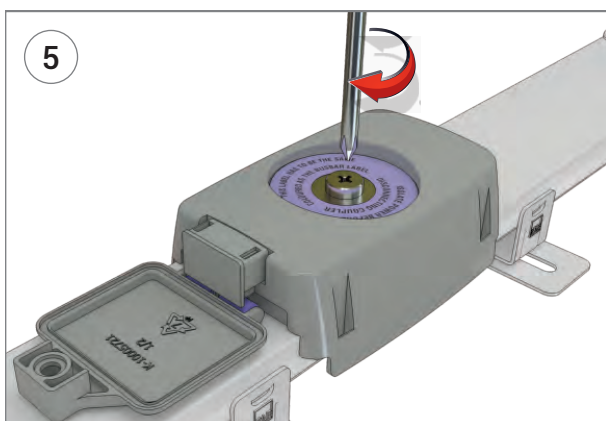

5- Tighten the main bolt of the joint pack to using a cross head screwdriver.

 **Warning:**

* Please do not remove the joint pieces which are sent equipped with the product.

DABLINE

Plug Installation

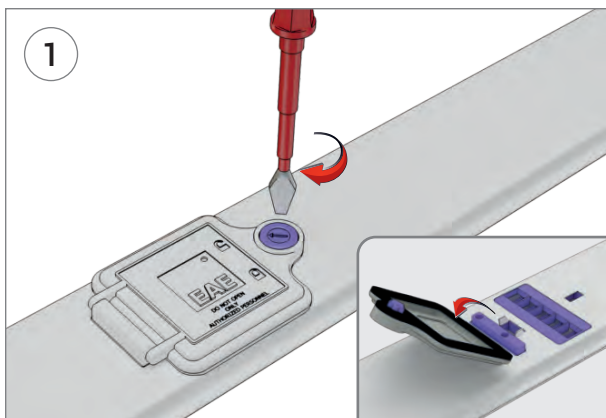

1- Open the socket cover.

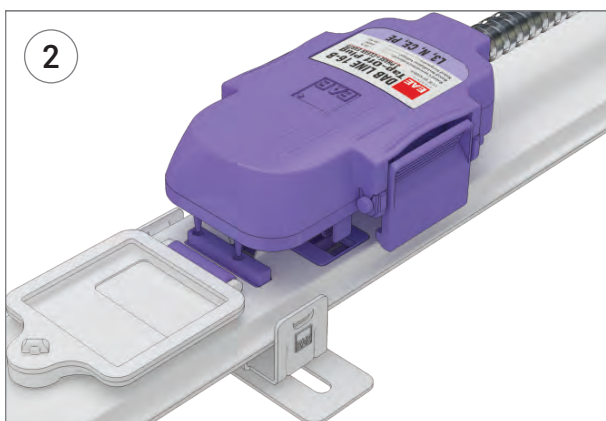

2- Insert the alignment pins of the Plug into the busbar alignment holes.

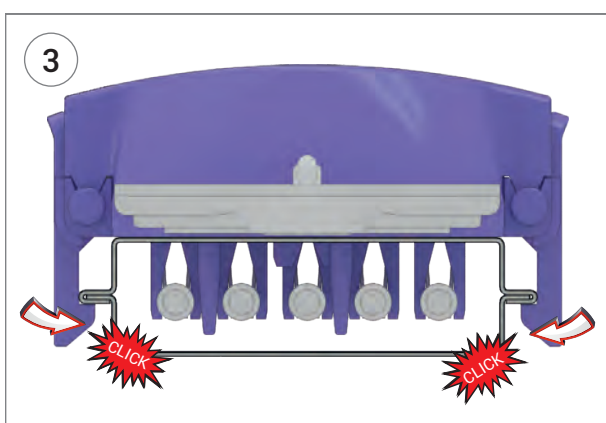
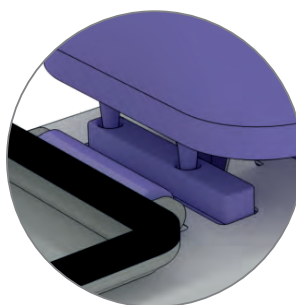

3- Make sure plug gripping parts (lugs) are gripped the channel. You should check, lugs are in the place essential to fully seated, as shown the figure.



Warning:

- * For your safety, do not cut the plug alignment pins, do not remove and do not changed their correct locations.
- * The plug cable connections must be completed before connecting the plug to the busbar.
- * Ensure that the load being supplied is in the "OFF" position.

DABLINE

Feeder Box Installation

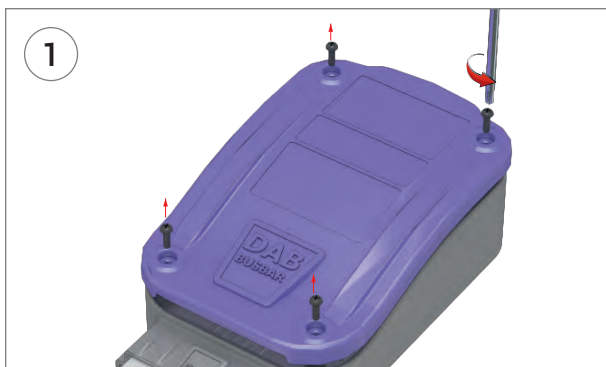

1- Remove the Feed Box cover by undoing the screws.

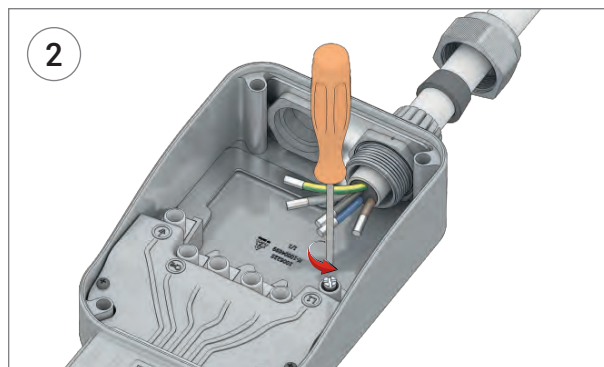

2- Feed cable should be used using the appropriate gland to complete the connection.

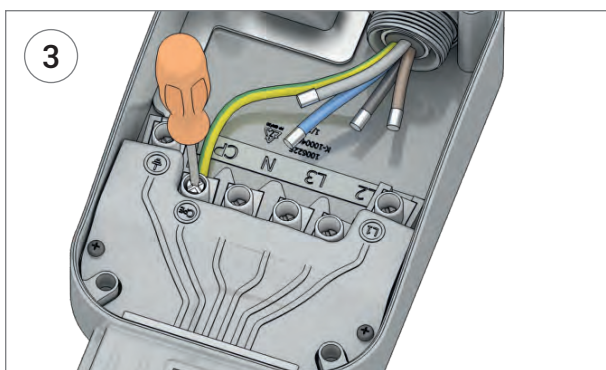

3- Bolts of phase and ground terminals are unscrewed enough for cable entry and screw the bolts to avoid the relocate the cables.

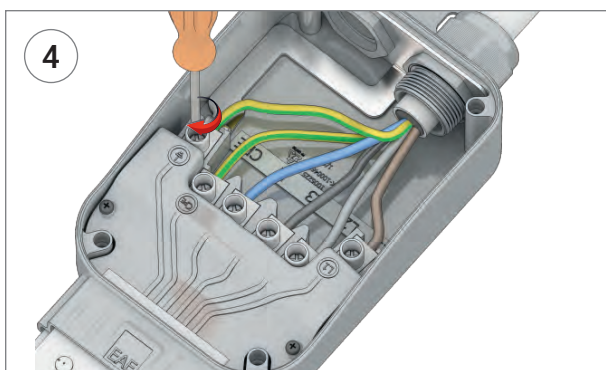
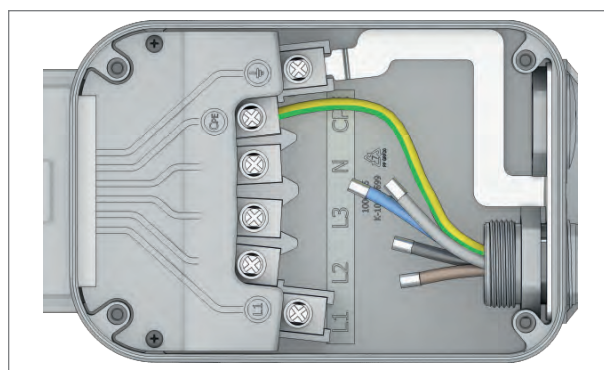

4- Complete the installation process by tightening the cable gland.

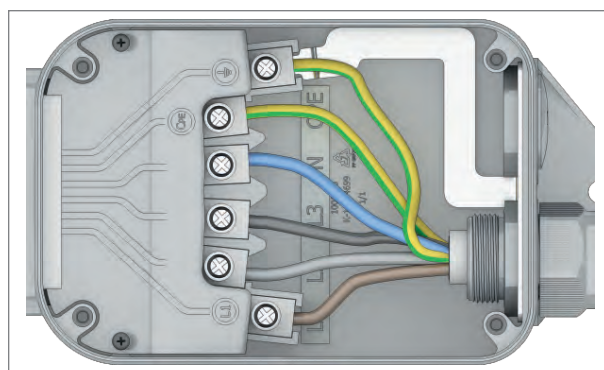

5- Refit the Feed Box cover by replacing the screws as shown. Be sure to use "U" support for the installation.

Warning:

- Ensure that the cable is not energised before starting the installation and the load supplied must be in the "OFF" position.
- Be sure to mount the "U" support under the feed module. The "U" support is included in the package.

DABLINE

Busbar System Installation

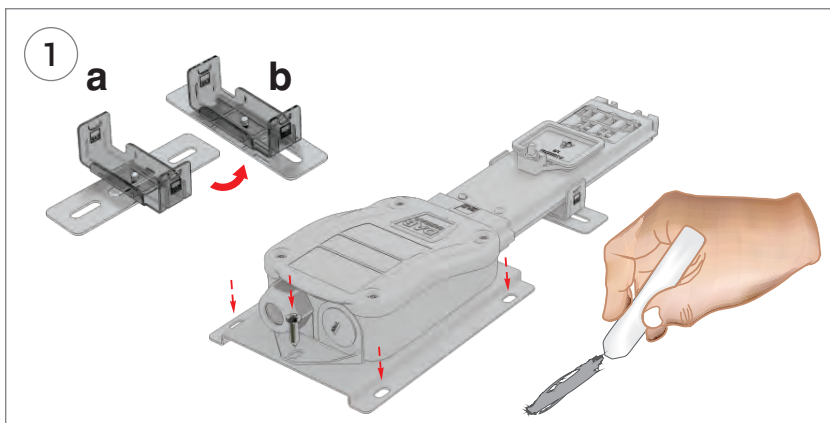

1- Mark out the route of busbar system where it will run . Make sure that, the line is clearly marked. Put a mark where it will be installed instead of the feed module and the end of the system. Fix the "U" support into place using with steel dowel and appropriate screw. Also fix the feed module to the "U" support with the screw included in the package.

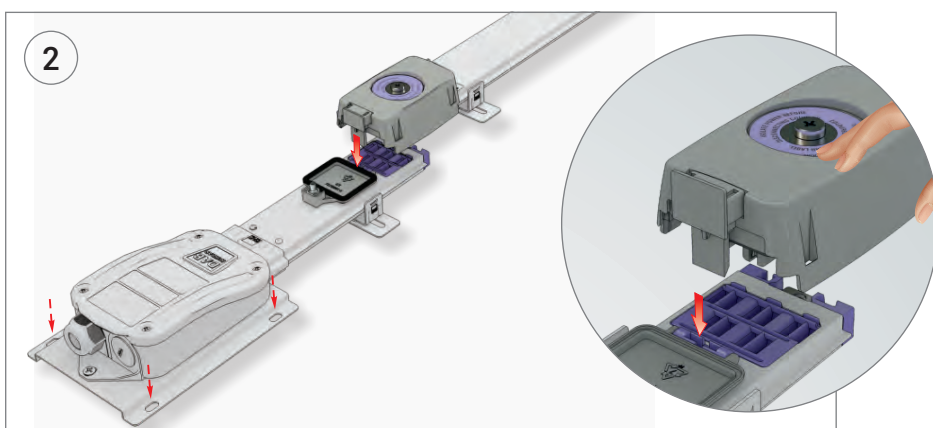

2- To join the two busbar lengths as shown in the picture left, the additional module alignment pin should be aligned with the slot in the other window.

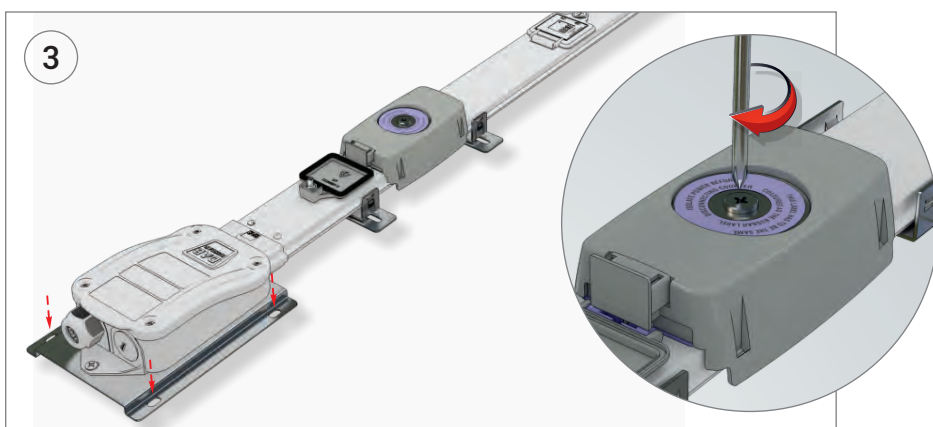

3- Tighten the main bolt of the joint pack to using a cross head screwdriver.

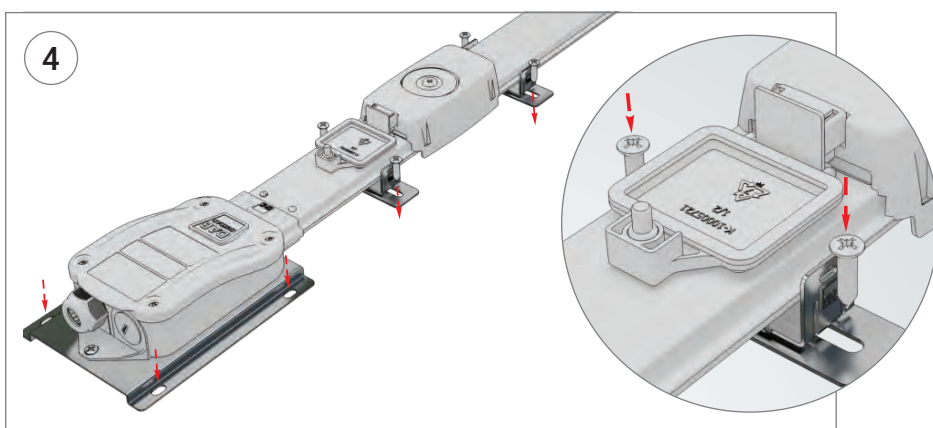

4- Fix the busbar systems to the base with the retractable support system. (Screws and anchors for mounting DABLINE Busbar System on the floor are not supplied by EAE.)

Note: It is suggested to use "U" Support under feeder and flexible modules.

DABLINE

Floor "U" Support Installation Manual

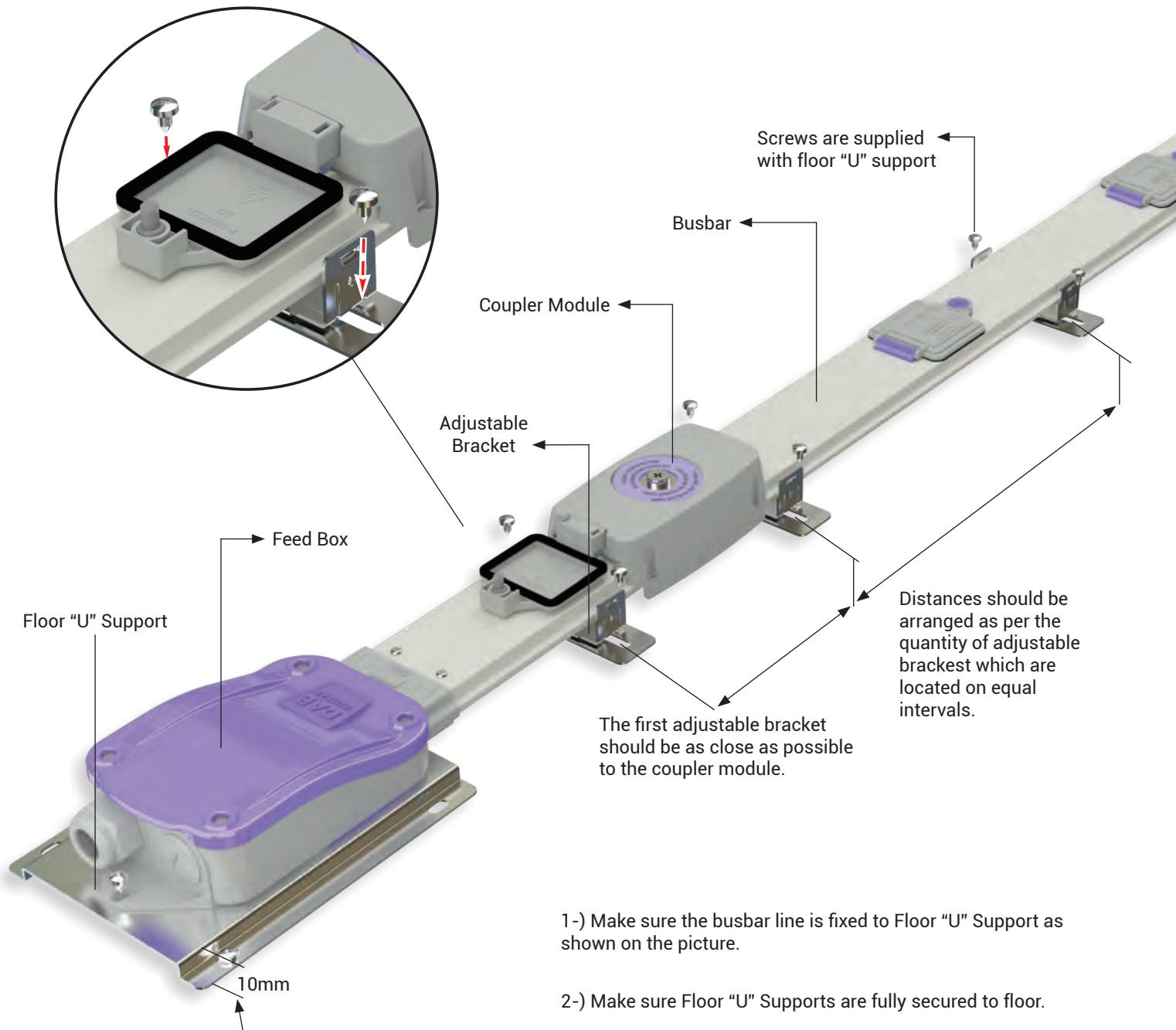

Floor "U" Support Details

(200x150x10mm)
200

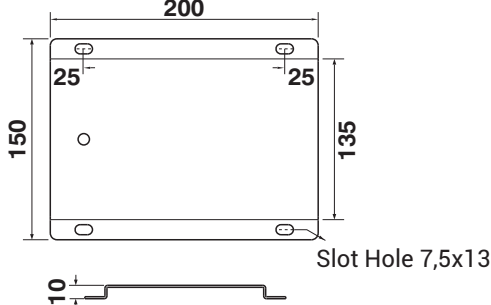

1-) Make sure the busbar line is fixed to Floor "U" Support as shown on the picture.

2-) Make sure Floor "U" Supports are fully secured to floor.

3-) The total height of busbar;

- from ground to feed module is 65mm with Floor "U" Support,
- from ground to coupler is 60mm with adjustable bracket,
- from ground to tap-off plug is 60mm with adjustable bracket,
- from ground to tap-off box is 130mm with adjustable bracket.

4-) Screws and anchors for mounting DABLINE Busbar System on the floor are not supplied by EAE.

5-) Screws for fixing adjustable bracket to floor "U" support are supplied with 2 pieces / floor "U" support by EAE.

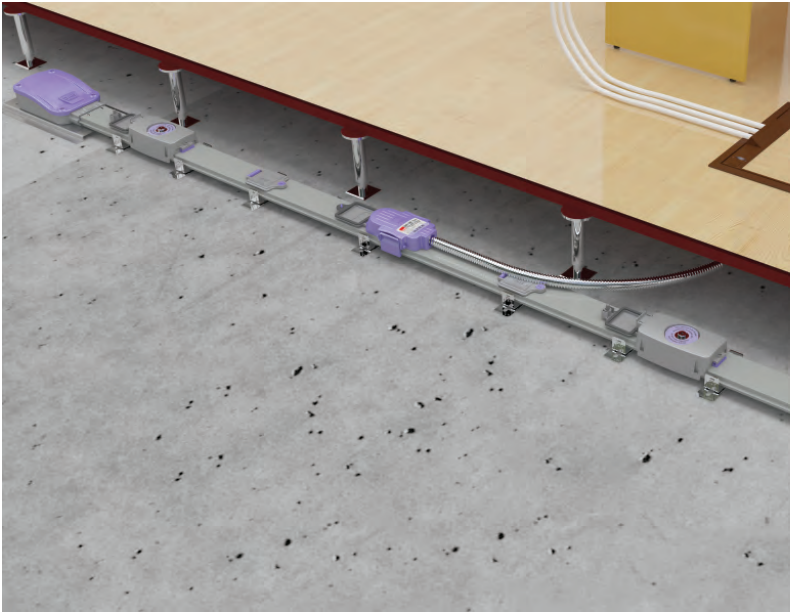

Advantages:

- Can be used in raised floor voids as low as 65mm in Office environments
- Suitable for to use in Data Control systems
- Easy mounting
- Up to 32 A outlet options
- Tek civata ile ek yapma imkânı
- Easy assembly with single bolt joint coupler
- Different Pin Codings for different types of busbar systems
- Different lengths of busbar can be achieved
- The contacts of the Tap-offs are silver plated

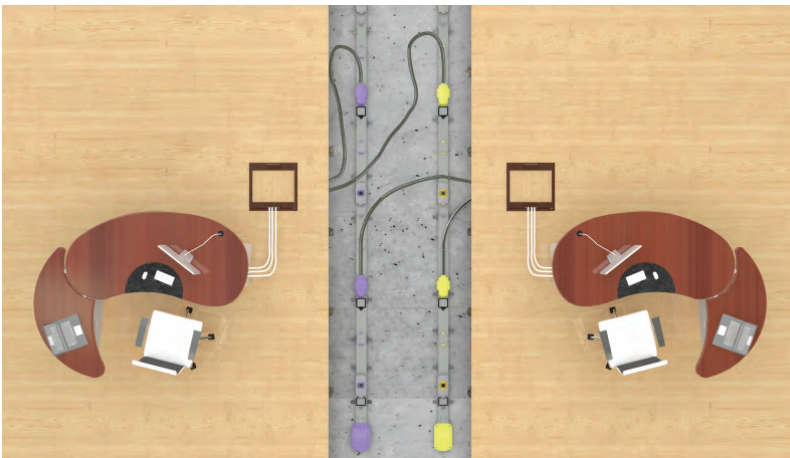

Application Areas:

- Banks
- Shopping Centres
- New Generation Offices
- Hotels
- Hospitals
- Conference Centres
- Educational Buildings
- Cinemas and theatres
- Tourist Facilities etc.

Sample DABLINE Installation

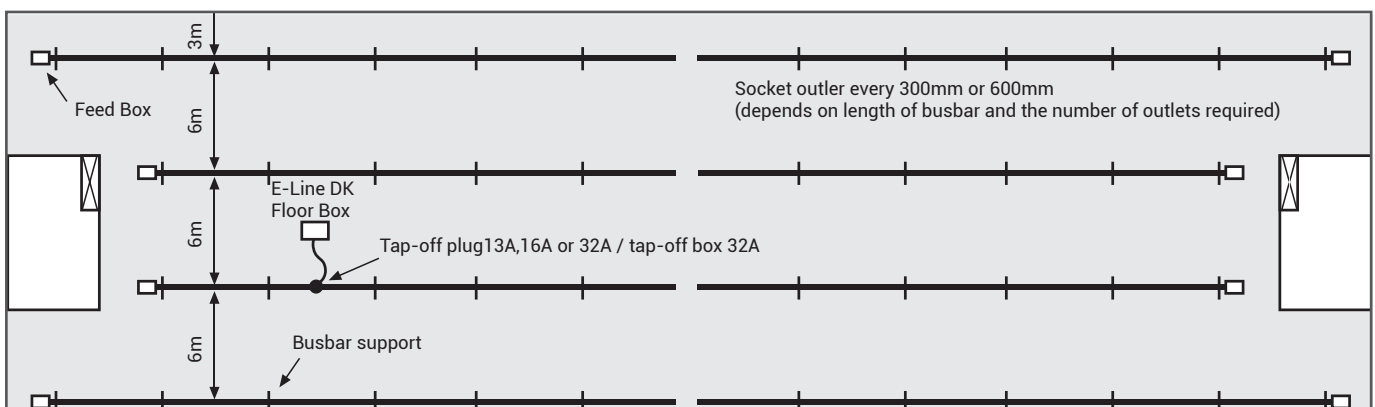

Busbar Systems;

- Shall have a type test report according to IEC 61439-6. The type test reports shall be from an internationally accepted third party laboratory.
- The Plug-in Busbar system shall have one of the following conductor number and configurations;
 - a) 4 conductors : L1 / L2 / L3 / N / PE (Housing) Coloured Yellow
 - b) 5 conductors: L1 / N1 / L2 / N2 / CE / PE (Housing) Coloured Blue
 - c) 5 conductors: L1 / L2 / L3 / N / CE / PE (Housing) Coloured Lilac
 The housing shall be used as the earth conductor
- The rated insulation voltage of the system shall be 690 V, shall have a rated current level of 63 and 80A, 50Hz., shall have tin plated copper conductors.
- Shall be produced as 1.2m, 2.4m and 3m straight lengths and there shall be plug-in outlets every 30cm or 60cm (optional) with IP55 protection plug-in outlet covers.
- IP protection degree of the busbars shall be 55.
- The housing of the busbar shall be manufactured from 0,60mm thick, epoxy painted (RAL 7038), galvanised sheet metal.
- The Support system shall be moveable and suitable for the busbar structure. Adjustable Fixing Bracket system shall be supplied as part of the busbar.
- Total height of the busbar system with all components shall be 65mm.
- The joint contact module shall provide continuous earth protection along the whole busbar line.
- The plug-in outlets shall be colour coded the same as the tap-offs to prevent incorrect connection of different types of busbars.

Busbar Systems Conductors;

- In the housing shall be continuously insulated and only exposed at the plug-in points to create the contact area.
- Shall be of electrolytic copper and continuously tin plated.
- Busbar joint contact points shall be silver plated.

Busbar Systems Outlet Plugs;

- Contacts of the tap-offs shall be of jaw structure, which contacts the conductors on both sides. The contacts shall have springs.
- The Tap-off Cable shall be to BS EN 50525-3-41 or TS EN 50525-3-31.
- The tap-off plugs shall have different colours and be addressable using pins for different types of busbar configuration.

Busbar Systems Dimensions

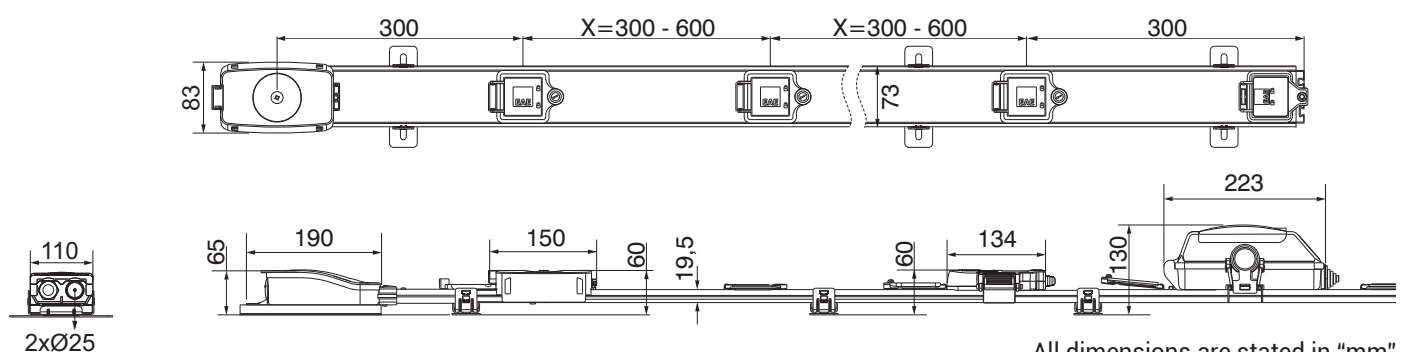

All dimensions are stated in "mm".

CE DECLARATION OF CONFORMITY

Product Group DABLINE Underfloor Busbar Systems

Manufacturer EAE Elektrik Asansor End. Insaat San. ve Tic. A.S.
Akcaburgaz Mahallesi, 3114. Sokak,
No:10 34522 Esenyurt-Istanbul

The objects of the declaration described below is in conformity with the relevant Union harmonisation legislation. This declaration of conformity is issued under the sole responsibility of the manufacturer.

Standard:

EN 61439-6

Low-voltage switchgear and controlgear assemblies - Part 6: Busbar trunking systems

IEC 61439-6

Low-voltage switchgear and controlgear assemblies - Part 6: Busbar trunking systems (busways)

CE - Directive:

2014/35/EU "The Low Voltage Directive"

2014/30/EU "Electromagnetic Compatibility (EMC) Directive"

2011/65/EU "Restriction of the use of certain hazardous substances (RoHS)"

Technical Documentation Preparation Authority

EAE Elektrik Asansor End. İnşaat San. ve Tic. A.S.
Akcaburgaz Mahallesi, 3114. Sokak, No:10, 34522 Esenyurt - İstanbul

Mustafa AKÇELİK

Date

08/03/2025

Document Signing Authority

Elif Gamze KAYA OK
Deputy General Manager



TEST CERTIFICATE

Issued to: EAE Elektrik Asansör Endustrisi
Insaat San. ve Tic. A.S.
Akçaburgaz Mahallesi 3114, Sokak No: 10
34510 Esenyurt / Istanbul
Turkey

For the product: Low-voltage busbar trunking system

Trade name: EAE

Type/Model: DAB Line 0604

Ratings: I_{nc} 63 A, U , 500 V, U_{imp} 6 kV, I_{cc} 16 kA at 400 V, IP55
For more details see annex

Manufactured by: EAE Elektrik Asansör Endustrisi
Insaat San. ve Tic. A.S.
Akçaburgaz Mahallesi 3114, Sokak No: 10
34510 Esenyurt / Istanbul
Turkey

Subject: Design verification

Requirements: IEC 61439-6: 2012
Clauses: 10.2.3, 10.2.6, 10.2.7, 10.2.101, 10.3, 10.4, 10.5, 10.9, 10.10, 10.11
and Annex BB, CC, and DD

Remarks: Date of performance of tests: 2013 and 2015
(see general notes on tests in the report)

This Test Certificate is granted on account of an examination by DEKRA, the results of which are laid down in report no. 2190123.01-INC, dated 9 May 2016.

The examination has been carried out on one single specimen of the product, submitted by the manufacturer. The Attestation does not include an assessment of the manufacturer's production. Conformity of his production with the specimen tested by DEKRA is not the responsibility of DEKRA.

Arnhem, 9 May 2016

Number: 2190123.100

DEKRA Certification B.V.



F.S. Strikwerda
Certification Manager

© Integral publication of this certificate and adjoining reports is allowed

DEKRA Certification B.V. Meander 1051, 6825 MJ Arnhem P.O. Box 5185, 6802 ED Arnhem, The Netherlands
T +31 88 96 83000 F +31 88 96 83100 www.dekra-certification.com Company registration 09085396

TEST CERTIFICATE

Issued to: EAE Elektrik Asansör Endustrisi
Insaat San. ve Tic. A.S.
Akçaburgaz Mahallesi 3114, Sokak No: 10
34510 Esenyurt / İstanbul
Turkey

For the product: Low-voltage busbar trunking system

Trade name: EAE

Type/Model: DAB Line 0804

Ratings: I_{nc} 80 A, U_i 500 V, U_{imp} 6 kV, I_{cc} 16 kA at 400 V, IP55
For more details see annex

Manufactured by: EAE Elektrik Asansör Endustrisi
Insaat San. ve Tic. A.S.
Akçaburgaz Mahallesi 3114, Sokak No: 10
34510 Esenyurt / İstanbul
Turkey

Subject: Design verification

Requirements: IEC 61439-6: 2012
Clauses: 10.2.3, 10.2.6, 10.2.7, 10.2.101, 10.3, 10.4, 10.5, 10.9, 10.10, 10.11
and Annex BB, CC, and DD

Remarks: Date of performance of tests: 2012, 2013 and 2015
(see general notes on tests in the report)

This Test Certificate is granted on account of an examination by DEKRA, the results of which are laid down in report no. 2190123.02-INC, dated 9 May 2016.

The examination has been carried out on one single specimen of the product, submitted by the manufacturer. The Attestation does not include an assessment of the manufacturer's production. Conformity of his production with the specimen tested by DEKRA is not the responsibility of DEKRA.

Arnhem, 9 May 2016

Number: 2190123.101

DEKRA Certification B.V.



F.S. Strikwerda
Certification Manager

© Integral publication of this certificate and adjoining reports is allowed

DEKRA Certification B.V. Meander 1051, 6825 MJ Arnhem P.O. Box 5185, 6802 ED Arnhem, The Netherlands
T +31 88 96 83000 F +31 88 96 83100 www.dekra-certification.com Company registration 09085396

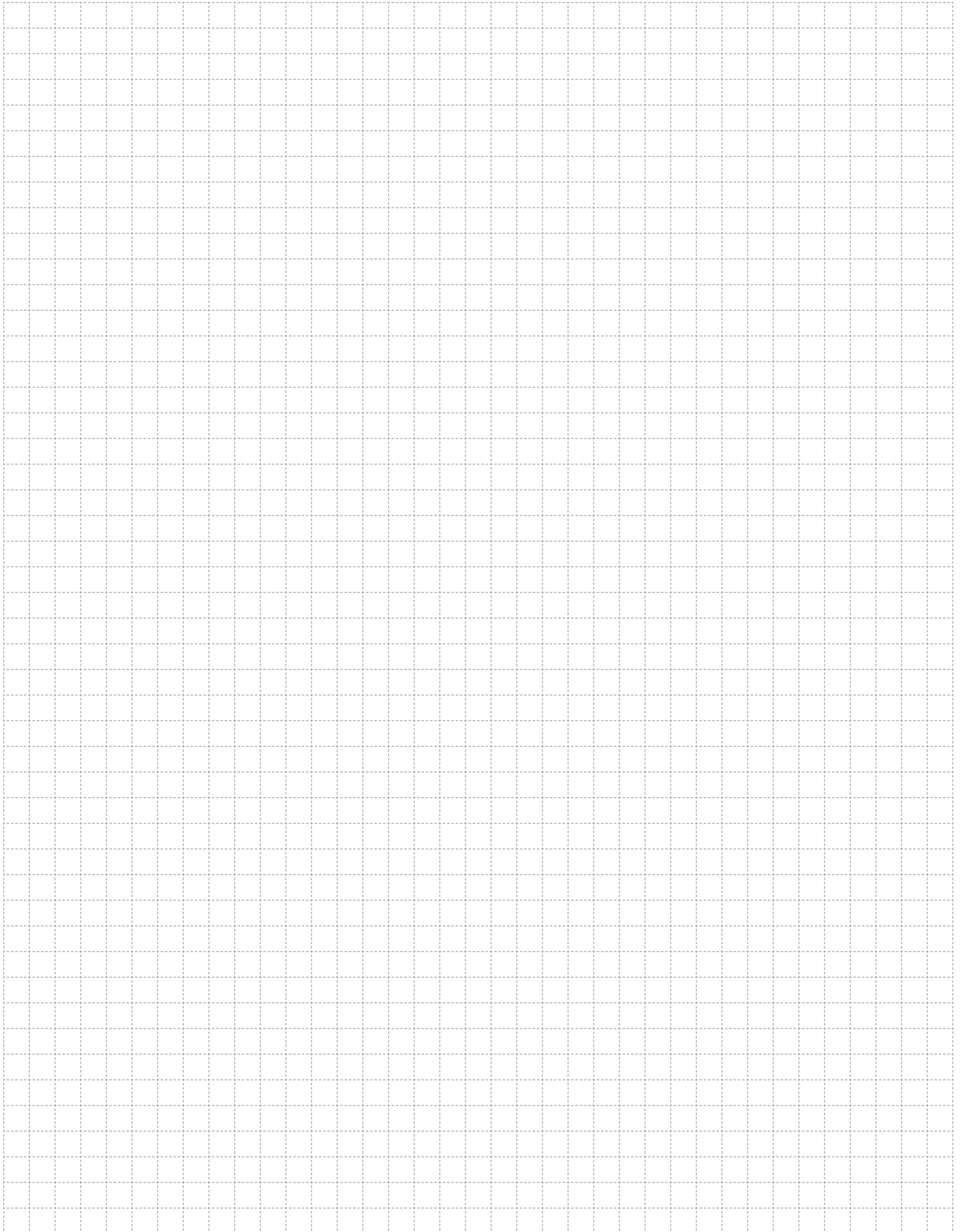

A large grid area for taking notes, consisting of a 20x30 grid of small squares. The grid is formed by dashed lines and occupies the majority of the page.

SUSTAINABLE FUTURE

Sustainability Management at EAE Elektrik



As part of our goal to support sustainable development and green transformation, measuring, evaluating, and managing all economic, environmental, and social impacts resulting from our sustainability practices is a key governance priority for EAE Elektrik. We act with great care in analyzing, monitoring, and managing the economic, environmental, and social impacts and risks that arise throughout our value chain in both our national and global operations.

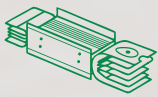

Busbar Systems

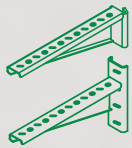

Support Systems

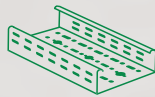

Cable Tray Systems

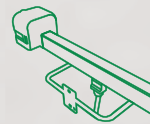

Trolley Busbar Systems



Fit-Out Solutions

"We are working together with all our stakeholders to develop the electrical technologies that will build the future."

You can visit our sustainability website at surdurulebilirik.eae.com.tr



#FutureTogether

EAE Elektrik
Head Office

Akcaburgaz Mahallesi,
3114. Sokak, No: 10 34522
Esenyurt - Istanbul - Turkiye
Tel: +90 (212) 866 20 00
Fax: +90 (212) 886 24 20

EAE DL 4 Factory
Busbar 2

Gebze IV Istanbul Makine ve Sanayicileri
Organize Bolgesi, 6.Cadde,
No:14/10 41455 Demirciler Koyu,
Dilovasi - Kocaeli - Turkiye
Tel: +90 (262) 999 05 55
Fax: +90 (262) 502 01 45



Please visit our website for the updated
version of our catalogues.
www.eaeelectric.com



Catalogue 16 - En. / Rev. 12 1000 Pcs. 22/01/2026
N.G.

EAE has full right to make any revisions or changes on this catalogue without any prior notice.