

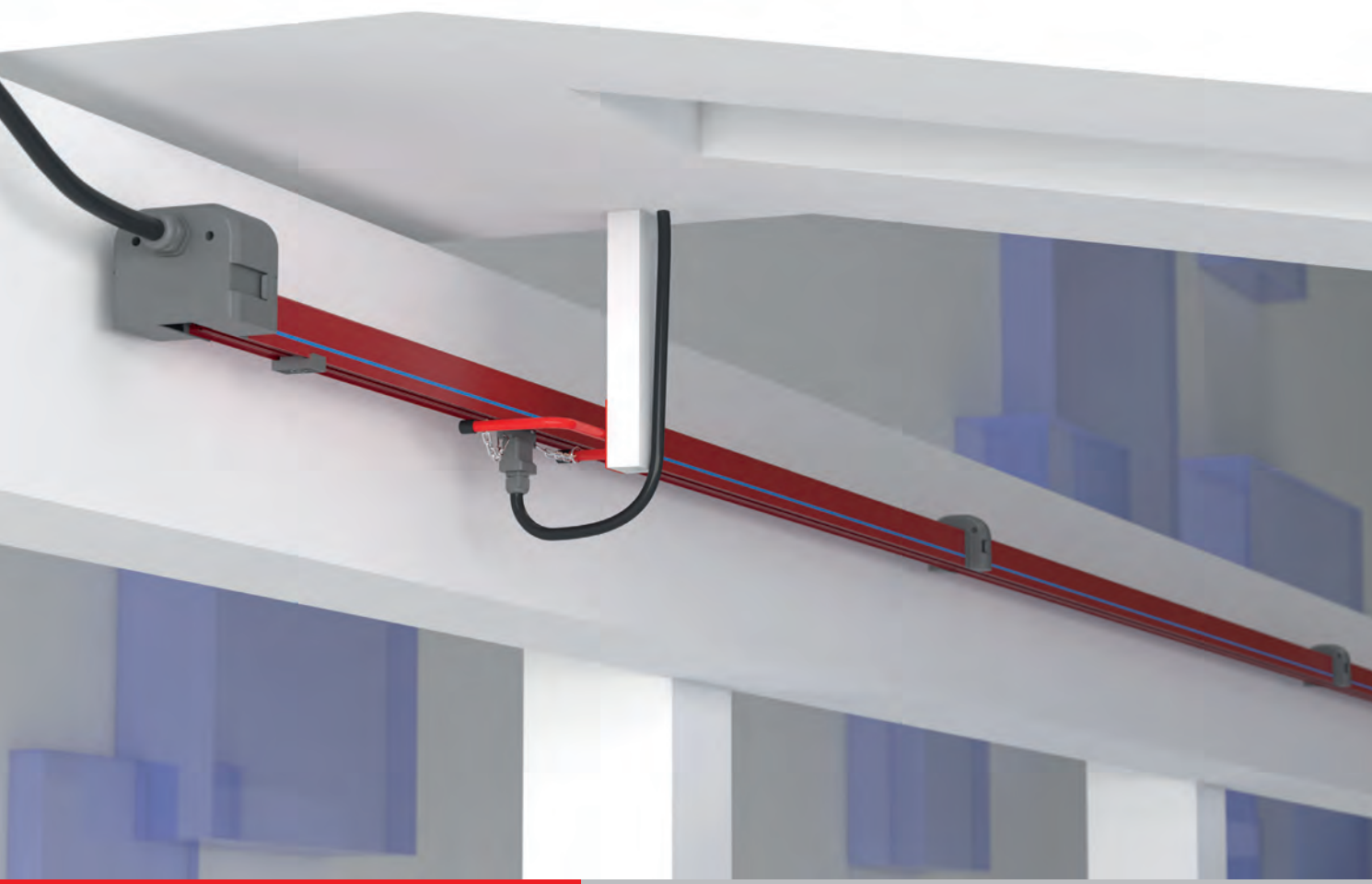

TBX-E



E-LINE TBX-E



• Bridge/Overhead Cranes



• Monorail Systems

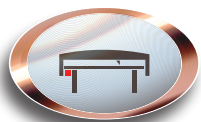

• Textile Cutting and Spreading Tables



• AS/RS Storage Systems



• Moving Ceiling and Door Systems



• Assembly and Test Lines

E-LINE TBX-E

Trolley Busbar Systems	2
Order Code System	3
TBX-E Trolley Busbar	4
TBX-E Feeder Unit	5
TBX-E Repair Zone Module	6
TBX-E Current Collector	7-8
System Components	9
System ComVoltage Drop, Calculation Of Feeding Pointsponents	10
TBX-E Trolley Busbar Installation Manual	11

E-LINE TBX-E

Trolley Busbar Systems



- Bridge/Overhead Cranes
- Monorail Systems
- Textile Cutting and Spreading Tables
- AS/RS Storage Systems
- Moving Ceiling and Door Systems
- Assembly and Test Lines

It consists of copper conductors and current collectors in the C-PVC body. The uninterrupted energy supply and movement of the system is provided by current collectors connected to the system mechanically.

The eliminates the possibilities such as accident, malfunction in energy distribution with suspended and reel cable in conventional systems. Conductors are enclosed in C-PVC housing and personnel safety is maximized.

There is no fixed connection between the conductor housings and the conductors and between the C-PVC housing and the sliding hangers, the necessary expansion opportunity is provided, therefore the expansion element is unrequired.

Cautions:

If it is used in external environments exposed to rain, it is recommended to protect it with a cover such as a canopy.



E-LINE TBX-E

Order Code System



TBX-E

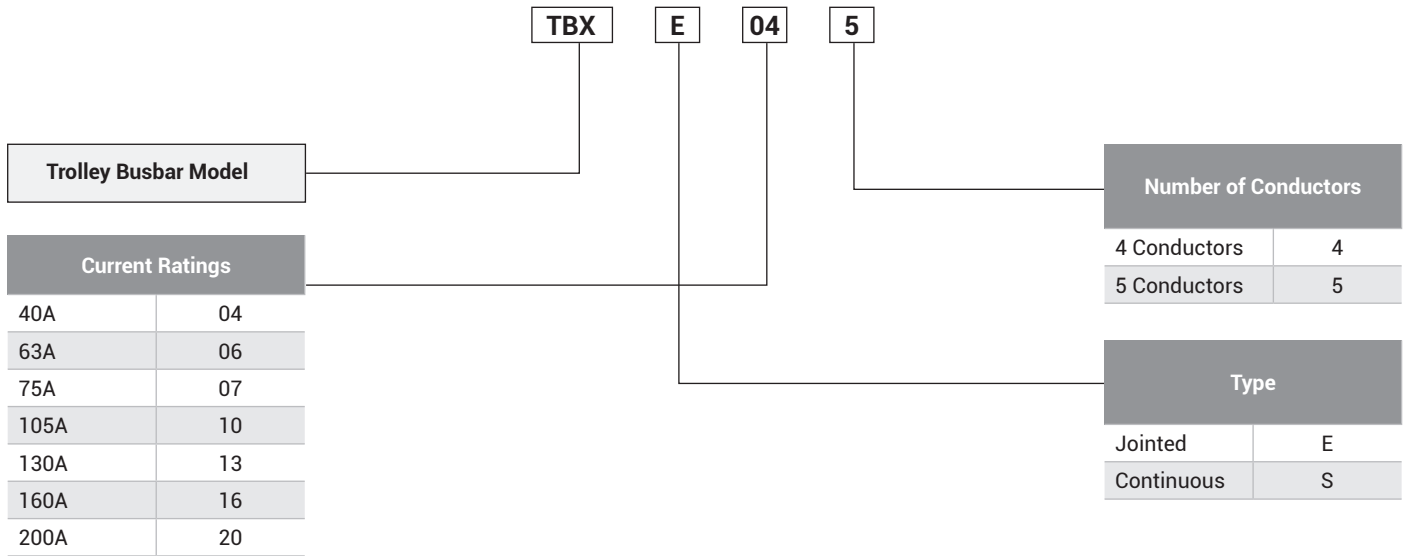

Technical Features

Rated Current	(A)	40	63	75	105	130	160	200
Conductor Quantities	(pcs)	4-5	4-5	4-5	4-5	4-5	4-5	4-5
Rated Voltage	(AC) (V)	690	690	690	690	690	690	690
Dielectric Properties	(kV/mm)	30	30	30	30	30	30	30
Frequency	(Hz)	50/60	50/60	50/60	50/60	50/60	50/60	50/60
Resistance (20°C)	R20 (mΩ/m)	1,440	1,240	1,150	0,780	0,600	0,450	0,400
Resistance (35°C)	R35 (mΩ/m)	1,580	1,425	1,340	0,910	0,700	0,530	0,510
Reactance	X (mΩ/m)	0,120	0,130	0,110	0,130	0,130	0,110	0,140
Impedance	Z (mΩ/m)	1,585	1,431	1,350	0,919	0,712	0,541	0,530
Standard Length	(m)	4	4	4	4	4	4	4

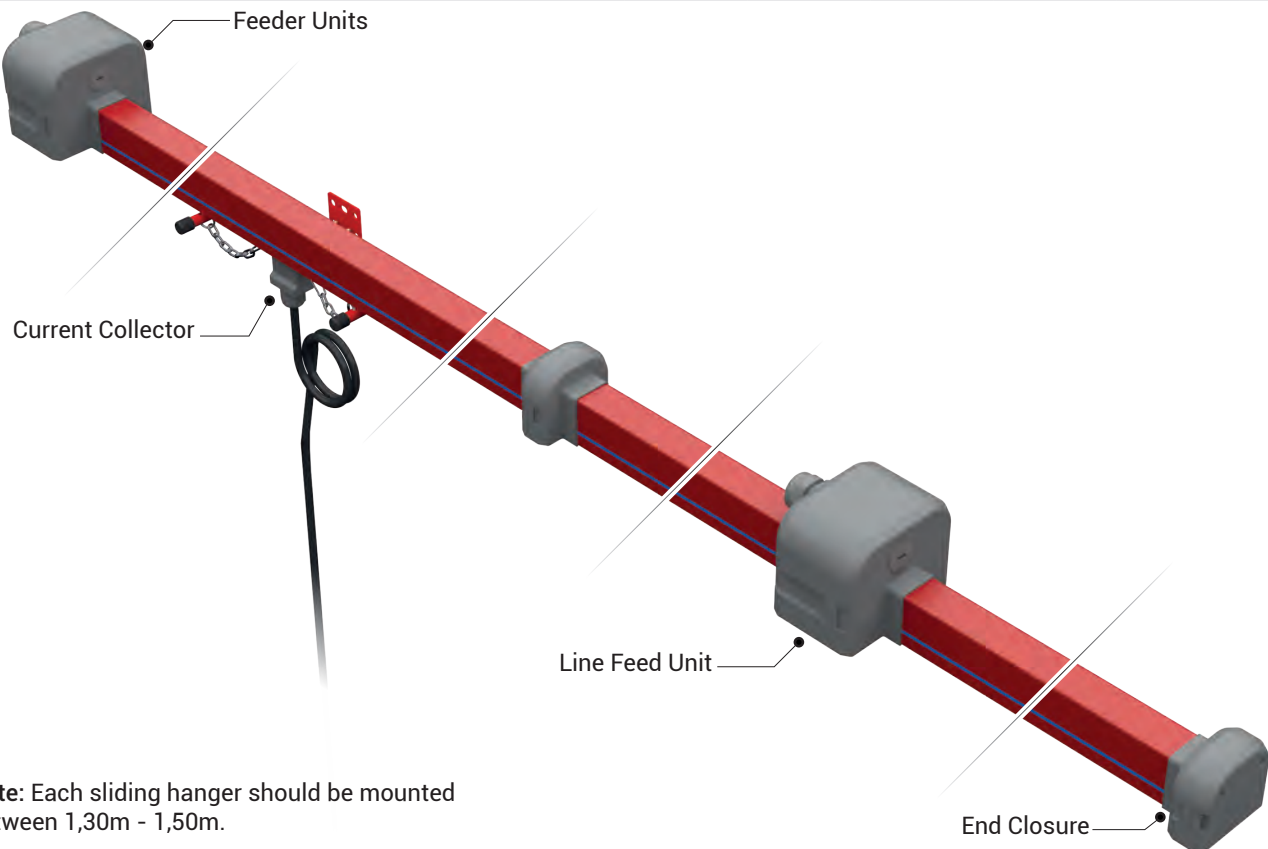

Note: Each sliding hanger should be mounted between 1,30m - 1,50m.

TBX-E Trolley Busbar

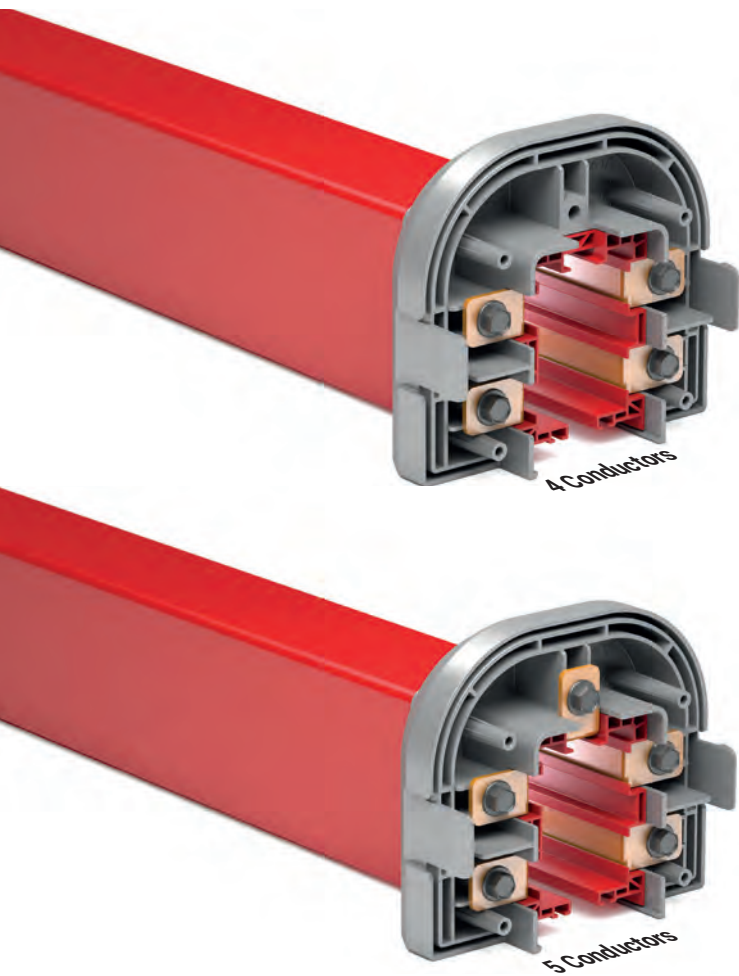

- **Number of Conductors:** 4 or 5 conductors
- **Colour:** Red.
- **Temperature range:** -40°C , +55°C.
- **Standard housing length:** 4 meters.
- **Protection:** Standard IP24, Gasket IP44
- **Non-Flammable Characteristics:** UL 94 V0
- Housing is made of C-PVC and plastic accessories are made of PA6 raw material.
- There is a neutral line on the housing the neutral conductor.
- Light and durable with double layer structure, TBX provides ease of installation.

Standard 4 Meters

Model	Conductors Quantity-Current (A)	Weight (gr/m)	Conductor Cross Section (mm ²)	Order Code
TBX-E 044	4P - 40A	1500	4x11,20	3135783
TBX-E 064	4P - 63A	1550	4x12,80	3179772
TBX-E 074	4P - 75A	1650	4x16,00	3135787
TBX-E 104	4P - 105A	1900	4x24,00	3135791
TBX-E 134	4P - 130A	2200	4x32,00	3135795
TBX-E 164	4P - 160A	2500	4x40,00	3136708
TBX-E 204	4P - 200A	2650	4x45,00	3292921
TBX-E 045	5P - 40A	1650	5x11,20	3135785
TBX-E 065	5P - 63A	1700	5x12,80	3179773
TBX-E 075	5P - 75A	1800	5x16,00	3135789
TBX-E 105	5P - 105A	2100	5x24,00	3135793
TBX-E 135	5P - 130A	2500	5x32,00	3135797
TBX-E 165	5P - 160A	2800	5x40,00	3136710
TBX-E 205	5P - 200A	3000	5x45,00	3292922

Description	Weight (gr/m)	Order Code
TBX-E Trolley Busbar Housing	820	2061764

The housing has a structure that can use maximum 5 conductors. There is safety system that prevents the current collector to be fixed inversely.

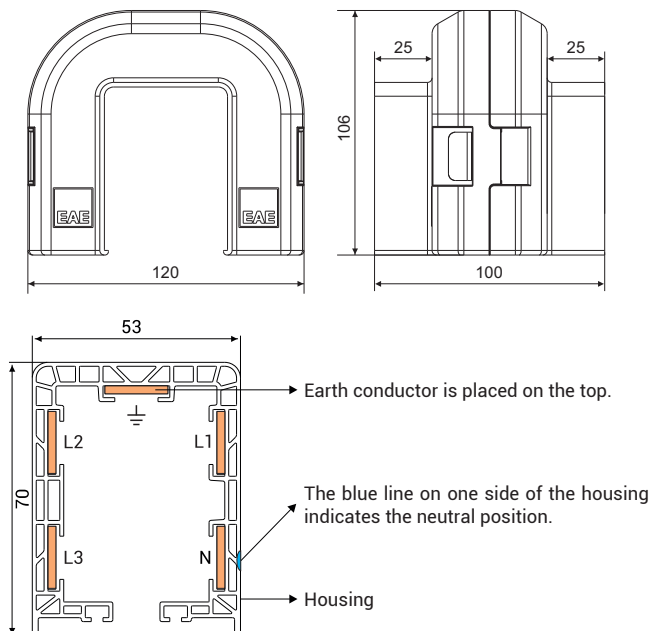

Special Length 1 or 2, 3 Meters

Model	Conductors Quantity-Current (A)	Weight (gr/m)	Conductor Cross Section (mm ²)	Order Code
TBX-E 044	4P - 40A	1500	4x11,20	3135782
TBX-E 064	4P - 63A	1550	4x12,80	3179776
TBX-E 074	4P - 75A	1650	4x16,00	3135786
TBX-E 104	4P - 105A	1900	4x24,00	3135790
TBX-E 134	4P - 130A	2200	4x32,00	3135794
TBX-E 164	4P - 160A	2500	4x40,00	3136707
TBX-E 204	4P - 200A	2650	4x45,00	3292919
TBX-E 045	5P - 40A	1650	5x11,20	3135784
TBX-E 065	5P - 63A	1700	5x12,80	3179777
TBX-E 075	5P - 75A	1800	5x16,00	3135788
TBX-E 105	5P - 105A	2100	5x24,00	3135792
TBX-E 135	5P - 130A	2500	5x32,00	3135796
TBX-E 165	5P - 160A	2800	5x40,00	3136709
TBX-E 205	5P - 200A	3000	5x45,00	3292920

Joint plastics are not included in the weight values.
Total weight of the joint plastics and bolts is 0.28 Kg.

E-LINE TBX-E



TBX-E

TBX-E Feeder Box

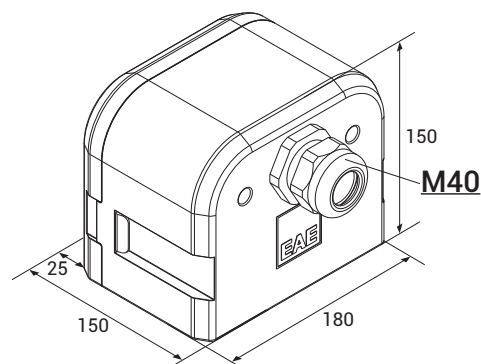

Description	Weight (gr/m)	Order Code
TBX Feeder Box	750	3135798

TBX-E Line Feed Box

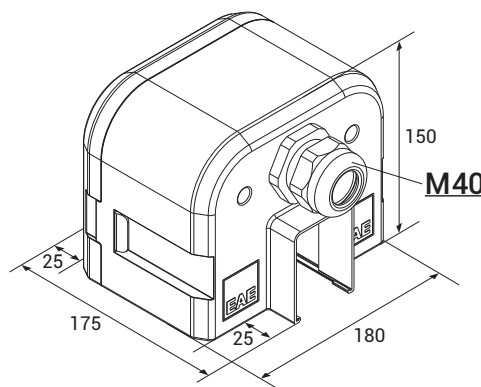

Description	Weight (gr/m)	Order Code
TBX Line Feed Box	750	3135799

Type of the feeding element is selected by calculating the voltage drop and the location of the power supply that shall provide power to the system.

TBX-E End Closure

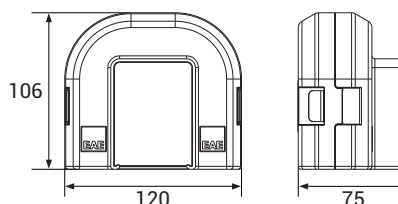

Description	Weight (gr/m)	Order Code
TBX-E End Closure	300	3197966

The end closure placed on the end of the busbar line prevents the exposure of the conductors, and protects the system.

TBX-E Repair Zone Unit

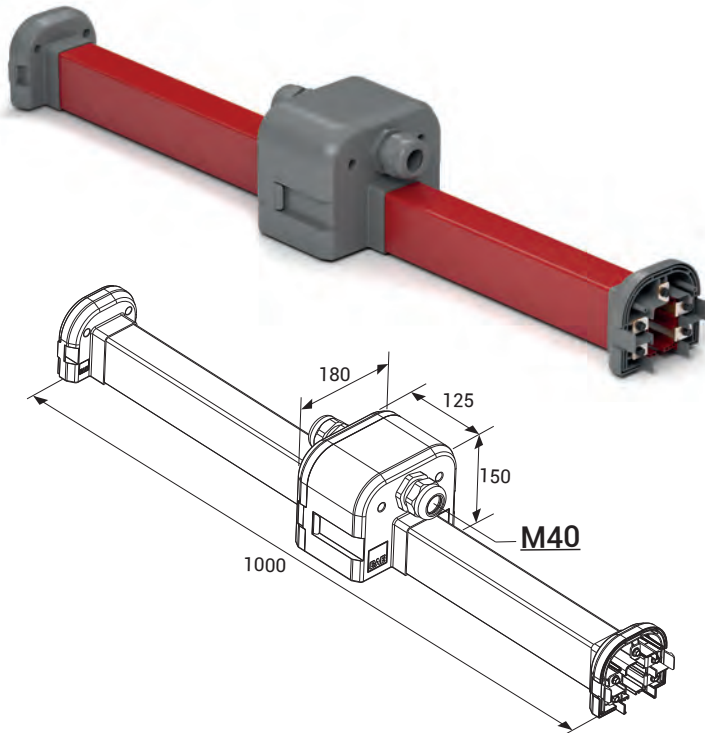

Model	Conductors Quantity-Current (A)	Weight (gr/m)	Conductor Cross Section (mm ²)	Order Code
TBX-E 044	4P - 40A	2450	4x11,20	3135819
TBX-E 064	4P - 63A	2500	4x12,80	3179782
TBX-E 074	4P - 75A	2550	4x16,00	3135821
TBX-E 104	4P - 105A	2850	4x24,00	3135823
TBX-E 134	4P - 130A	3150	4x32,00	3135826
TBX-E 164	4P - 160A	3400	4x40,00	3136711
TBX-E 204	4P - 200A	3550	4x45,00	3292917
TBX-E 045	5P - 40A	2550	5x11,20	3135820
TBX-E 065	5P - 63A	2600	5x12,80	3179783
TBX-E 075	5P - 75A	2700	5x16,00	3135822
TBX-E 105	5P - 105A	3050	5x24,00	3135824
TBX-E 135	5P - 130A	3400	5x32,00	3135827
TBX-E 165	5P - 160A	3750	5x40,00	3136712
TBX-E 205	5P - 200A	3950	5x45,00	3292918

Current supply shall be cut off when a machine working on the line shall be maintained or repaired. Repair zone module is used to create a currentless area on the busbar so that the other machines operating on the same line may continue to work.

TBX-E Current Collector Replacement Module

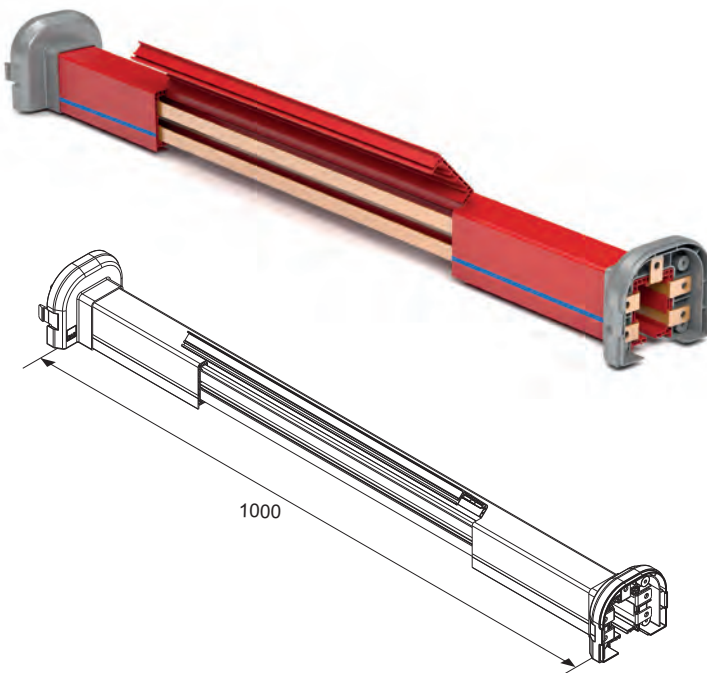

Model	Conductors Quantity-Current (A)	Weight (gr/m)	Conductor Cross Section (mm ²)	Order Code
TBX-E 044	4P - 40A	1700	4x11,20	3233909
TBX-E 064	4P - 63A	1750	4x12,80	3233910
TBX-E 074	4P - 75A	1800	4x16,00	3233911
TBX-E 104	4P - 105A	2100	4x24,00	3233912
TBX-E 134	4P - 130A	2400	4x32,00	3233913
TBX-E 164	4P - 160A	2700	4x40,00	3233914
TBX-E 204	4P - 200A	2850	4x45,00	3292915
TBX-E 045	5P - 40A	1800	5x11,20	3233915
TBX-E 065	5P - 63A	1850	5x12,80	3233916
TBX-E 075	5P - 75A	1950	5x16,00	3233917
TBX-E 105	5P - 105A	2300	5x24,00	3233918
TBX-E 135	5P - 130A	2700	5x32,00	3233919
TBX-E 165	5P - 160A	3000	5x40,00	3233920
TBX-E 205	5P - 200A	3200	5x45,00	3292916

This unit is used to remove an existing current collector or to add extra trolleys. The unit is obtained by cutting a 50 cm section from the PVC housing.

TB5 Current Collectors With Cable

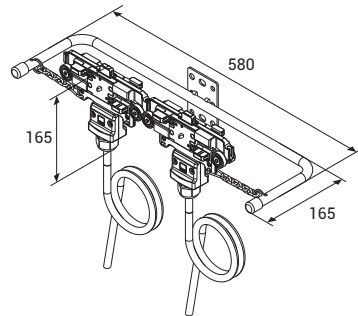
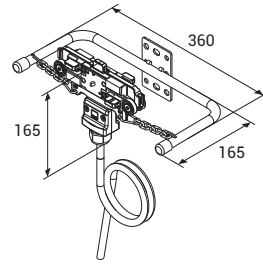

Model	Brushes Number-Current (A)	Weight (gr)	Order Code
TB5	4P - 35A (Single)	1700	3024385
	4P - 70A (Double)	2950	3024386
	4P - 105A (Triple)	4450	3024387
	5P - 35A (Single)	1900	3024376
	5P - 70A (Double)	3250	3024377
	5P - 105A (Triple)	4700	3024378

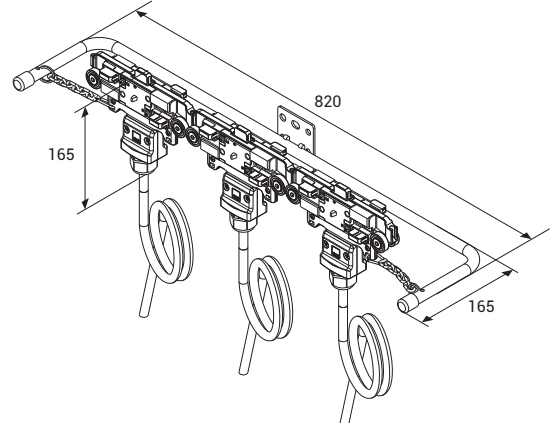

Model	Brushes Number-Current (A)	Weight (gr)	Order Code
TB5	4P - 60A (Single)	2000	3203193
	4P - 120A (Double)	3550	3269558
	5P - 60A (Single)	2200	3203194
	5P - 120A (Double)	3850	3269559

TB5 Current Collectors With Clip

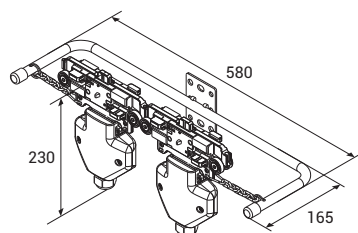
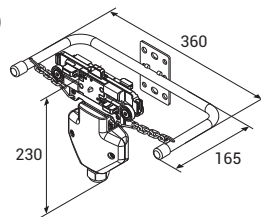
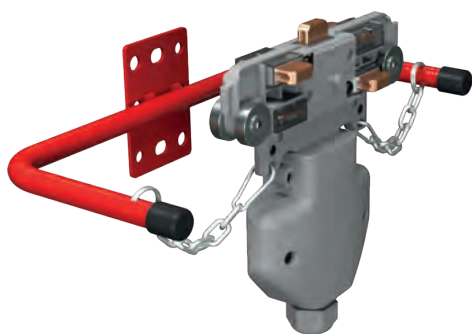

Model	Brushes Number-Current (A)	Weight (gr)	Order Code
TB5	4P - 35A (Single)	1350	3024388
	4P - 70A (Double)	2050	3024389
	4P - 105A (Triple)	3050	3024390
	5P - 35A (Single)	1350	3024379
	5P - 70A (Double)	2250	3024380
	5P - 105A (Triple)	3200	3024381

• Produced with standard M40 cable gland and 4mm² clip.

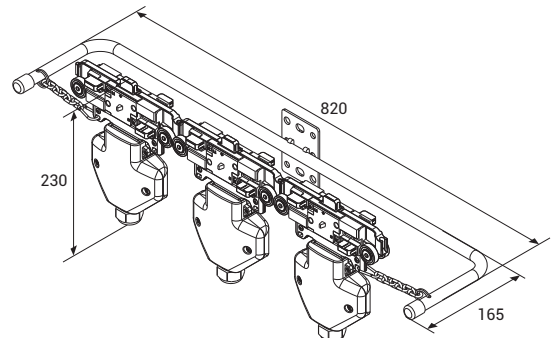

Current collector with clips allow the customers to perform cabling as they desire with the clips they include.

Current collector are the moving elements of the trolley busbar systems. Current collector brushes rub against the conductors and draw continuous current while they move through the busbar line. They adapt to shaky and vibrant conditions thanks to the moving brushes. As current collecting and transfer systems are included in the C-PVC housing, they are protected against human contact.

E-LINE TBX-E



TB5 Current Collector With Fuse Box

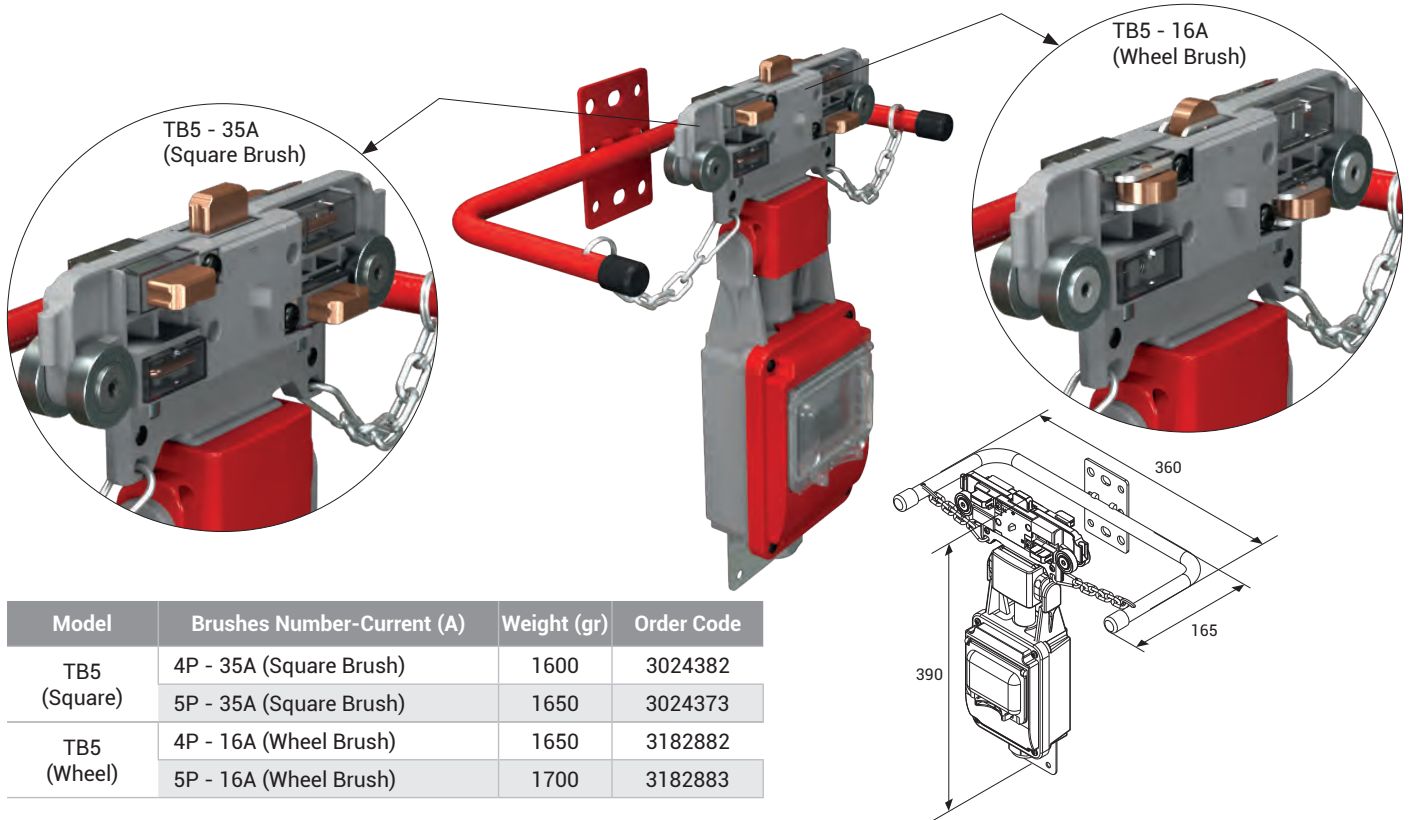

Model	Brushes Number-Current (A)	Weight (gr)	Order Code
TB5 (Square)	4P - 35A (Square Brush)	1600	3024382
	5P - 35A (Square Brush)	1650	3024373
TB5 (Wheel)	4P - 16A (Wheel Brush)	1650	3182882
	5P - 16A (Wheel Brush)	1700	3182883

Fuse boxed with both staff and current receiving area carts current machine's safety can be raised to a higher level. In addition, when it is desired to cut the power of one of the machines on a line, the current is cut off through the fuse, other machines on the line can continue to operate.

Current collector with Wheel Brush simplify the movement of the current collectors inside the busbar by reducing the time at the installation tables when movement is provided by the personnel.

TB5 Current collector models operating speed is max. 100m/min.

TB5 Current Collector Brushes

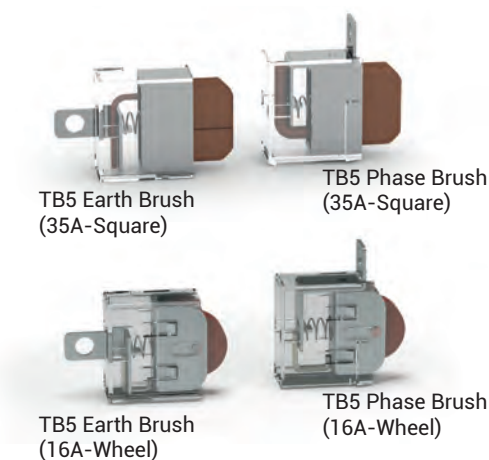

Description	Weight (gr)	Order Code
TB5 Phase Brush (35A-Square)	40	3024371
TB5 Earth Brush (35A-Square)	40	3024372
TB5 Phase Brush (16A-Wheel)	40	3165078
TB5 Earth Brush (16A-Wheel)	40	3165080

TBX Trolley Transfer Tool



Description	Weight (gr)	Order Code
TBX Trolley Transfer Tool	250	3179529

E-LINE TBX-E



TBX-E

TB5 Plastic Sliding Hanger

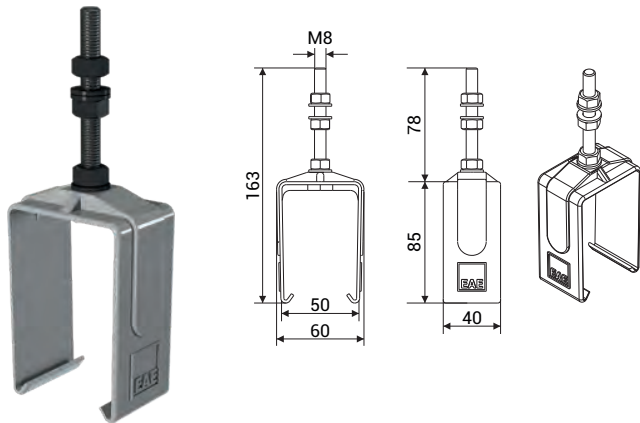

TB5 Steel Sliding Hanger

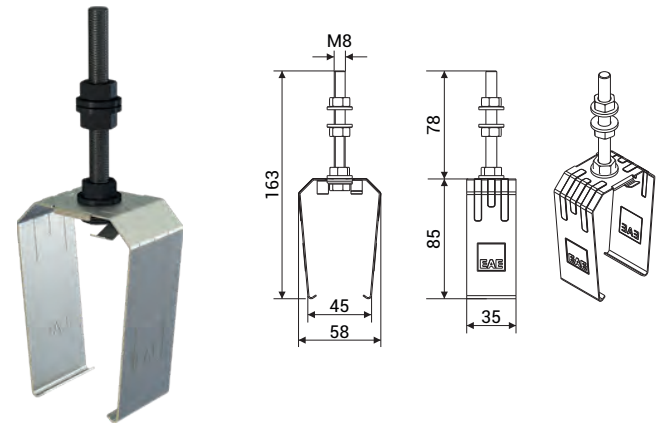

Trolley busbar should be mounted with sliding hangers and each hangers should be between 1,30m - 1,50m. Distance between sliding hanger and other units (joint unit, feeder etc.) should be minimum 300mm.

Description	Weight (gr)	Order Code
TB5 Plastic Sliding Hanger	85	1003664

Description	Weight (gr)	Order Code
TB5 Steel Sliding Hanger	100	1005954

TB Hanger Bracket

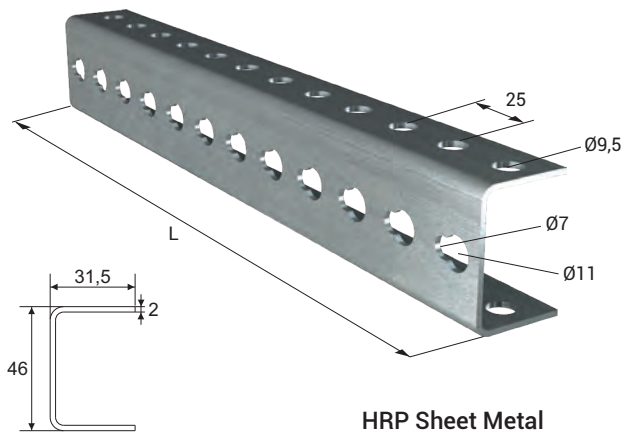

HRP Sheet Metal

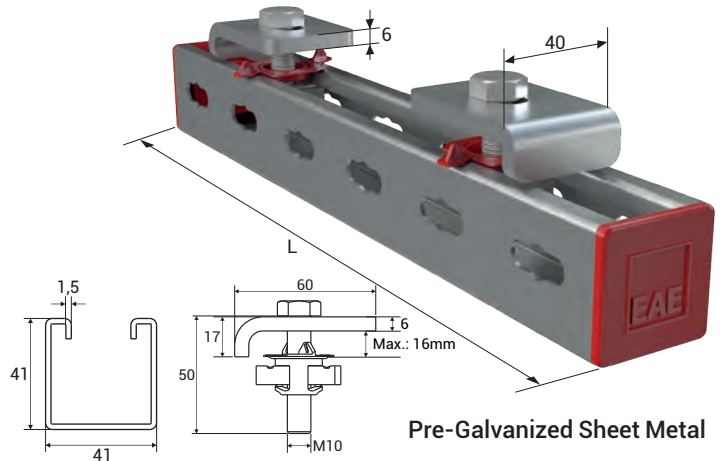

Pre-Galvanized Sheet Metal

Description	L (mm)	Weight (gr)	Order Code
TB Hanger Bracket	250	350	3025153
URC-C/S Hanger Bracket	500	700	3034560
URC-A Hanger Bracket	750	1050	3025382

Description	L (mm)	Weight (gr)	Order Code
TB BR Hanger Bracket Set	300	800	3178916
URC-C/S BR Hanger Bracket Set	600	1250	3178917
URC-A BR Hanger Bracket Set	800	1550	3178918

• Please browse the MFIX catalog to see our various support solutions.

TBX Gasket

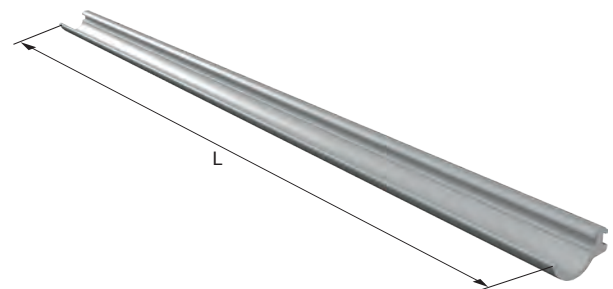

• Continuous length is maximum 300 meters.

• Gasket should be ordered twice the line length.

Description	Weight (gr)	Order Code
TBX Gasket Roll (m)	30	1037761

Description	L (mm)	Weight (gr)	Order Code
TBX Gasket Straight Length (Pcs.)	4000	120	1037762

Voltage Drop

The voltage drop in the busbar lines shall be inspected as per the busbar type selected according to the total current calculated based on the ambient temperature and operating period of the system. Maximum acceptable value for voltage drop is 3%.

For Direct Current

$$\Delta U = 2 \cdot L_t \cdot I_G \cdot R$$

ΔU = Voltage Drop [V]

For Mono-Phase Alternative Current

$$\Delta U = 2 \cdot L_t \cdot I_G \cdot Z$$

I_G = Total current [A]

R = Resistance of the busbar [Ω/m]

For Three-Phase Alternative Current

$$\Delta U = \sqrt{3} \cdot L_t \cdot I_G \cdot Z$$

Z = Impedance of the busbar [Ω/m]

L_t = Calculated Hole Length [m]

Note : Calculation of the current drawn during first start in various motor types;

I_A = Total current drawn in the first start of the motors [A]

For the starting current; Three-phase asynchronous drive in direct start

I_A = I_G x calculated as 5 to 6

Slip ring rotor motor

I_A = I_G x calculated as 2 to 3

Frequency converter

I_A = I_G x 1,20 to 1,50 calculated between.

Calculation Of Feeding Points

When we take L_t as the length of the line, feeding points may be selected as shown in the diagrams below to keep the L voltage drop at minimum and it may be used as the hole length for the calculation of L_t voltage drop.



1 feeding point from the start, $L_t=L$

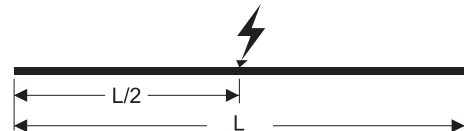

1 feeding point from the center, $L_t=L/2$



2 feeding points from the start points, $L_t=L/4$



2 feeding points, $L_t=L/6$

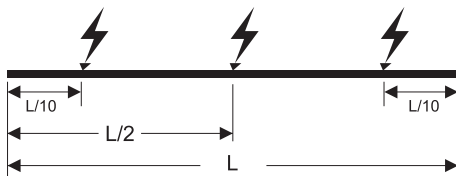

3 feeding points, $L_t=L/10$

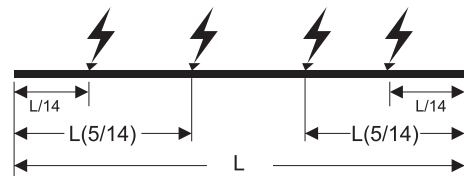

4 feeding points, $L_t=L/14$

E-LINE TBX-E

Installation Manual

TBX-E - Installation Of Joint Unit

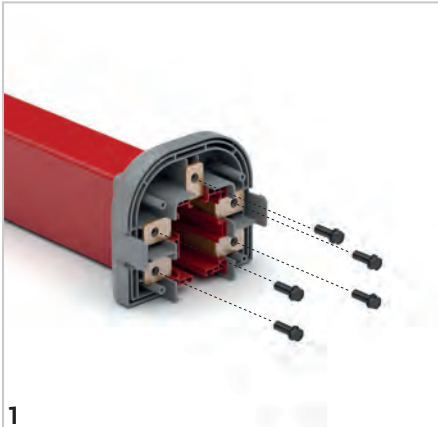

1 Remove the screws on the end of the busbar.

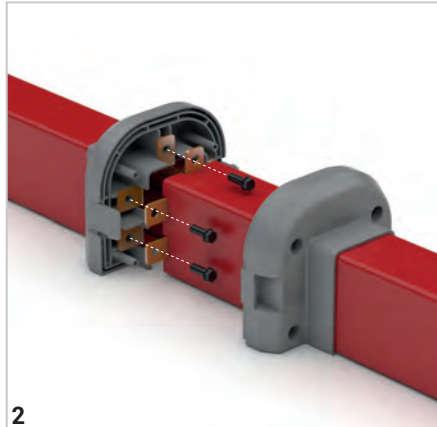

2 Join it with the other busbar and screw it.

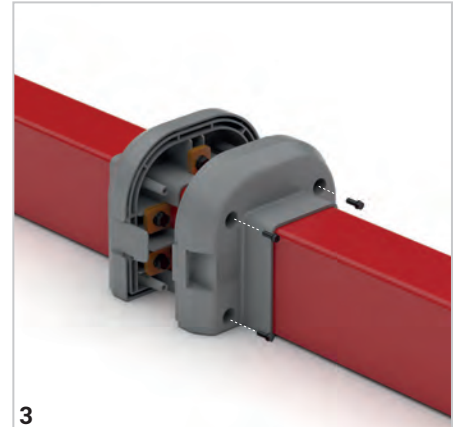

3 Close the joint cover and screw it.

TBX-E - Feeder Unit

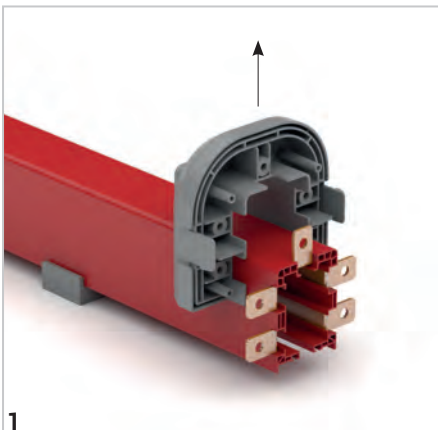

1 Joint unit cover is removed.

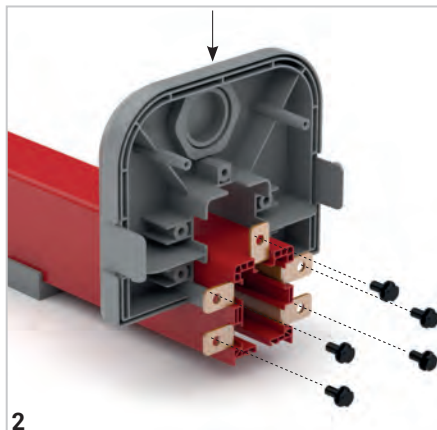

2 The small part of the feed box is inserted into the busbar from the top and the conductor are screwed.

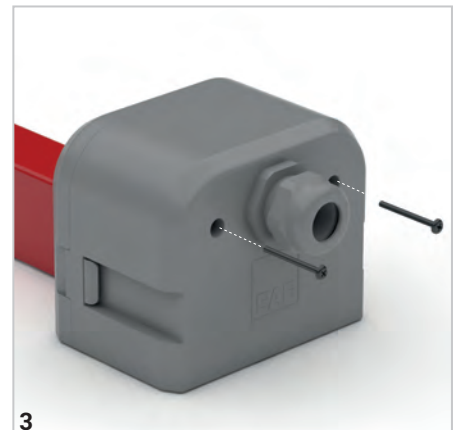

3 Close the module cover and screw it. It is inserted with a cable from the M40 cable gland and it is feed.

TBX-E - Line Feed Unit

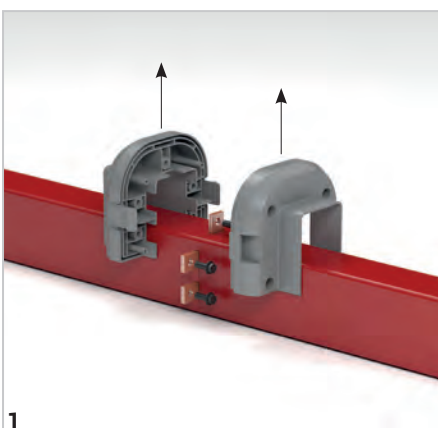

1 Joint unit is removed it upwards.

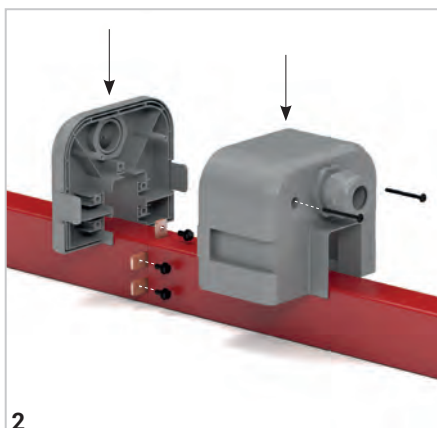

2 The feeder box is placed in the busbar from the top. The supply cable are connected to the conductors through the cable gland. The cover is closed and screwed.

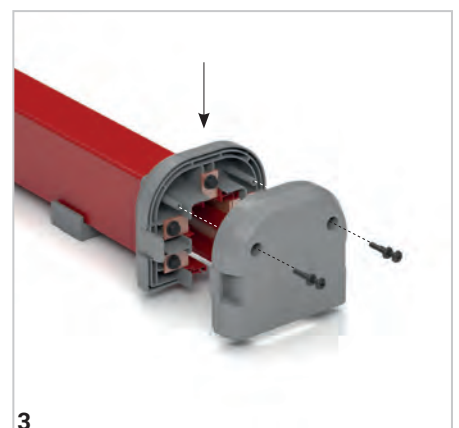

3 Install the end closure to the end of the housing and screw it.

TBX-E - End Closure

DECLARATION

CE DECLARATION OF CONFORMITY

Product Group E-Line TB Trolley Busbar Systems
Manufacturer Akcaburgaz Mahallesi, 3114. Sokak,
No:10 34522 Esenyurt-Istanbul

The objects of the declaration described below is in conformity with the relevant Cable gland harmonisation legislation. This declaration of conformity is issued under the sole responsibility of the manufacturer.

Standard:

TS EN 61439-6

Low-voltage switchgear and controlgear assemblies - Part 6: Busbar trunking systems

CE - Directive:

2014/35/EU "The Low Voltage Directive"

2014/30/EU "(EMC) Electromagnetic Compatibility Directive"

2011/65/EU "RoHS Directive"

Technical Document Preparation Official:

EAE Elektrik Asansor End. Insaat San. Tic. A.S.
Akcaburgaz Mahallesi, 3114. Sokak, No:10 34522 Esenyurt-Istanbul

Mustafa AKÇELİK

Date

20.03.2026

Document Authorized Signatory

Elif Gamze KAYA OK
Deputy General Manager



SUSTAINABLE FUTURE

Sustainability Management at EAE Elektrik



As part of our goal to support sustainable development and green transformation, measuring, evaluating, and managing all economic, environmental, and social impacts resulting from our sustainability practices is a key governance priority for EAE Elektrik. We act with great care in analyzing, monitoring, and managing the economic, environmental, and social impacts and risks that arise throughout our value chain in both our national and global operations.

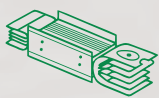

Busbar Systems

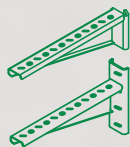

Support Systems

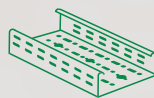

Cable Tray Systems

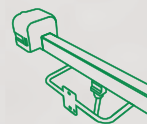

Trolley Busbar Systems



Fit-Out Solutions

"We are working together with all our stakeholders to develop the electrical technologies that will build the future."

You can visit our sustainability website at sustainability.eaeelectric.com



#FutureTogether

EAE Elektrik
Head Office

Akcaburgaz Mahallesi,
3114. Sokak, No: 10 34522
Esenyurt - Istanbul - Turkiye
Tel: +90 (212) 866 20 00
Fax: +90 (212) 886 24 20

EAE DL 4 Factory
Busbar 2

Organize Sanayi Bolgesi Mahallesi,
6. Cadde, No: 14/10, 41455
Dilovasi - Kocaeli - Turkiye
Tel: +90 (262) 999 05 55
Fax: +90 (262) 502 01 45



Please visit our website for the updated
version of our catalogues.
www.eaelectric.com



Catalogue 08 - En. / Rev. 16 0 Pcs. 25/05/2026
E.U.

EAE has full right to make any revisions or changes on this catalogue without any prior notice.