

TBS

E-LINE TBS



• Bridge Cranes



• Monorail Systems

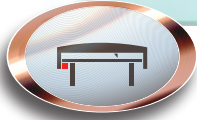

• Textile Cutting and Spreading Tables



• AS/RS Storage Systems



• Moving Ceiling and Door Systems



• Assembly and Test Lines

E-LINE TBS

| | |
|---|-------|
| Trolley Busbar Systems | 2 |
| Order Code System | 3 |
| TBS PVC Housing..... | 4 |
| TBS Feeder Unit | 5-6 |
| TBS Repair Zone | 7 |
| TBS Current Collector | 8-9 |
| System Components | 10-11 |
| Voltage Drop, Calculation Of Feeding Points | 12 |
| TBS Trolley Busbar Installation Manual | 13-14 |

E-LINE TBS

Trolley Busbar Systems



- Bridge Cranes
- Monorail Systems
- Textile Cutting and Spreading Tables
- AS/RS Storage Systems
- Moving Ceiling and Door Systems
- Assembly and Test Lines

It consists of copper conductors and current collectors in the C-PVC body. The uninterrupted energy supply and movement of the system is provided by current collectors connected to the system mechanically.

The eliminates the possibilities such as accident, malfunction in energy distribution with suspended and reel cable in conventional systems. Conductors are enclosed in C-PVC housing and personnel safety is maximized.

There is no fixed connection between the conductor housings and the conductors and between the C-PVC housing and the sliding hangers, the necessary expansion opportunity is provided, therefore the expansion element is unrequired.

Cautions:

If it is used in external environments exposed to rain, it is recommended to protect it with a cover such as a canopy.



E-LINE TBS

Order Code System

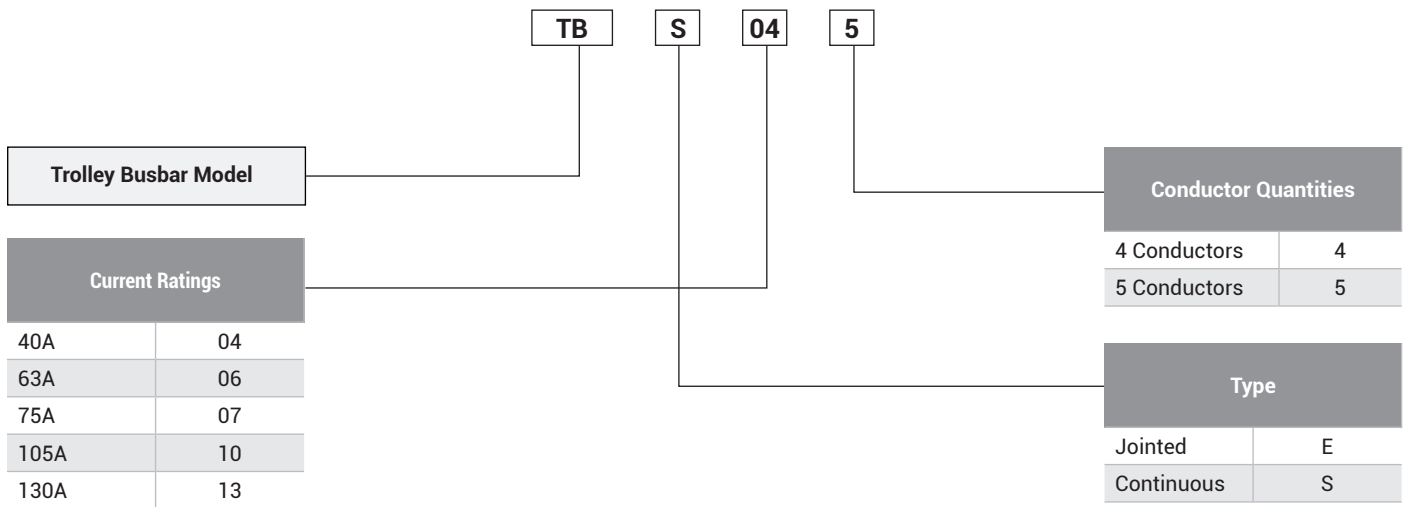

Technical Features

| Rated Current | (A) | 40 | 63 | 75 | 105 | 130 |
|-----------------------|------------|-------|-------|-------|-------|-------|
| Conductor Quantities | (pcs) | 4-5 | 4-5 | 4-5 | 4-5 | 4-5 |
| Rated Voltage | (AC) (V) | 690 | 690 | 690 | 690 | 690 |
| Dielectric Properties | (kV/mm) | 30 | 30 | 30 | 30 | 30 |
| Frequency | (Hz) | 50/60 | 50/60 | 50/60 | 50/60 | 50/60 |
| Resistance (20°C) | R20 (mΩ/m) | 1,300 | 1,018 | 1,280 | 0,800 | 0,570 |
| Resistance (35°C) | R35 (mΩ/m) | 1,420 | 1,176 | 1,460 | 0,920 | 0,660 |
| Reactance | X (mΩ/m) | 0,160 | 0,447 | 0,140 | 0,060 | 0,250 |
| Impedance | Z (mΩ/m) | 1,429 | 1,258 | 1,467 | 0,922 | 0,706 |
| Standard Length | (m) | 4 | 4 | 4 | 4 | 4 |

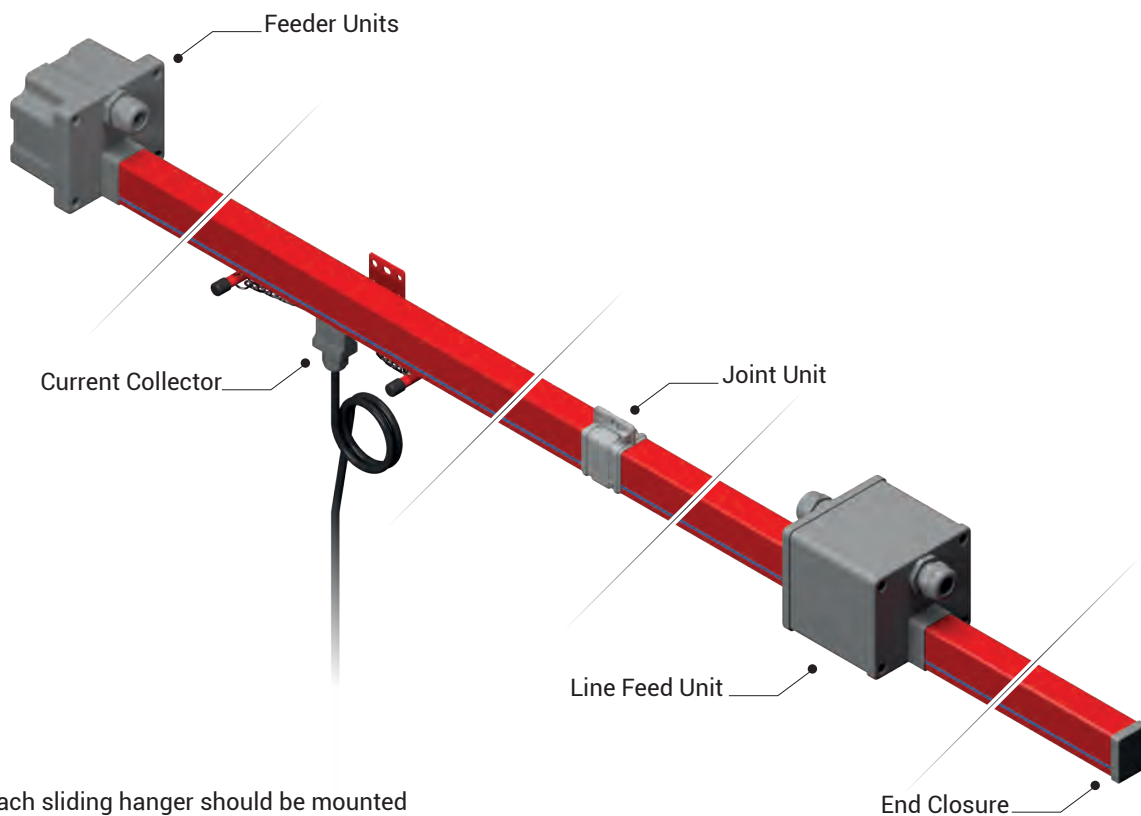

Note: Each sliding hanger should be mounted between 1,30m - 1,50m.

TBS Trolley Busbar

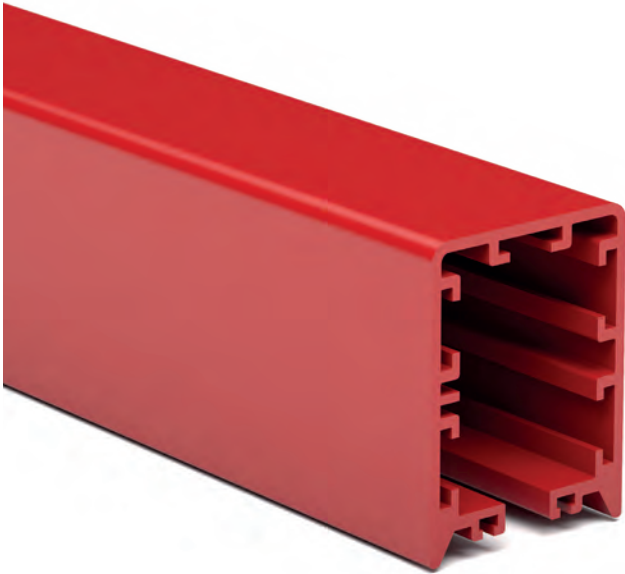

| Description | Weight (gr/m) | Order Code |
|----------------------------|---------------|------------|
| TB5 Trolley Busbar Housing | 1250 | 2037290 |

The housing has a structure that can use maximum 5 conductors. There is safety system that prevents the current collector to be fixed inversely.

Continuous Copper Conductors

Electrolytic copper conductors can be applied without interruption at a maximum length of 150 m.

- **Number of Conductors:** 4 or 5 conductors
- **Colour:** Red.
- **Temperature range:** -40°C , +55°C.
- **Standard housing length:** 4 meters.
- **Protection:** Standard IP24, Gasket, IP44.
- **Non-Flammable Characteristics:** UL 94 V0
- Housing is made of C-PVC and plastic accessories are made of PA6 raw material.
- Conductors are protected against hand contact inside the insulating housing.
- There is a neutral line on the housing indicating the neutral conductor.

Standard 4 Meters

| Model | Conductors Quantity-Current (A) | Weight (gr/m) | Conductor Cross Section (mm ²) | Order Code |
|---------|---------------------------------|---------------|--|------------|
| TBS 044 | 4P - 40A | 1700 | 4x11,20 | 3024465 |
| TBS 064 | 4P - 63A | 1750 | 4x12,80 | 3182880 |
| TBS 074 | 4P - 75A | 1900 | 4x16,00 | 3024466 |
| TBS 104 | 4P - 105A | 2200 | 4x24,00 | 3024467 |
| TBS 134 | 4P - 130A | 2450 | 4x32,00 | 3024468 |
| TBS 045 | 5P - 40A | 1800 | 5x11,20 | 3024461 |
| TBS 065 | 5P - 63A | 1850 | 5x12,80 | 3182877 |
| TBS 075 | 5P - 75A | 2050 | 5x16,00 | 3024462 |
| TBS 105 | 5P - 105A | 2400 | 5x24,00 | 3024463 |
| TBS 135 | 5P - 130A | 2750 | 5x32,00 | 3024464 |

Joint plastics are not included in the weight values.
Total weight of the joint plastics and bolts is 100 gr.

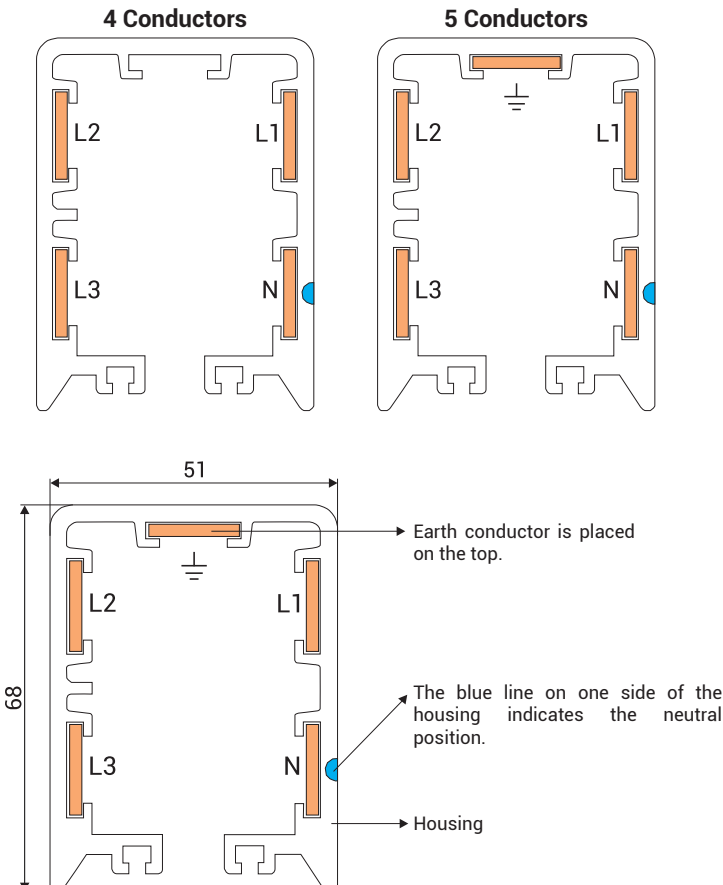

Radius Trolley Busbar

It has minimum 1.5m radius Trolley Busbar available in vertical axes.

- Radius Trolley Lines can be applied with maximum 4 conductors.
- We recommend to use housing pins at joint units of radius trolley lines.

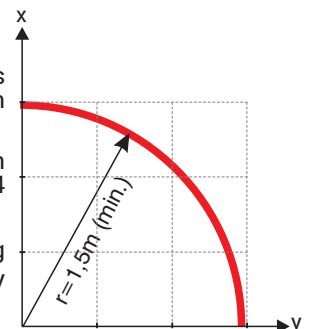

TBS Feeder Units

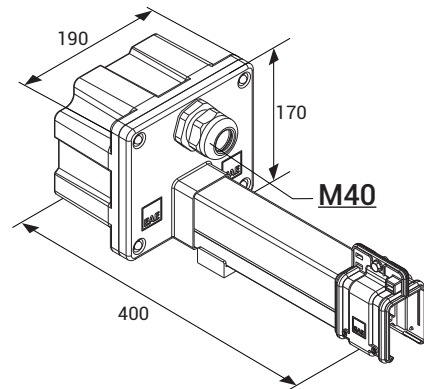
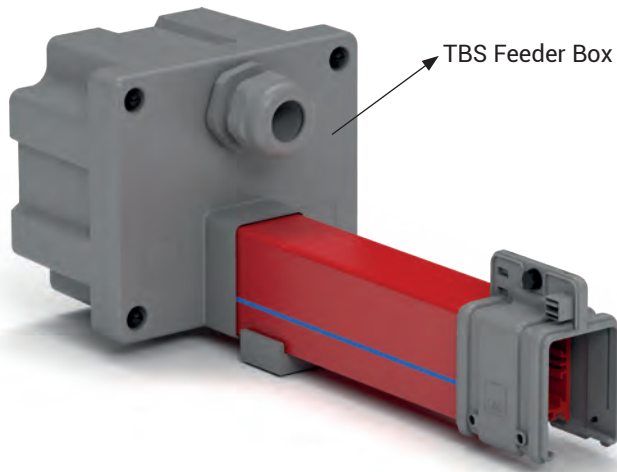

| Description | Weight (gr) | Order Code |
|------------------|-------------|------------|
| TBS Feeder Units | 1000 | 3024457 |
| TBS Feeder Box | 650 | 3179927 |

Type of the feeder box is selected by calculating the voltage drop and the location of the power supply that shall provide power to the system.

TBS Joint Unit

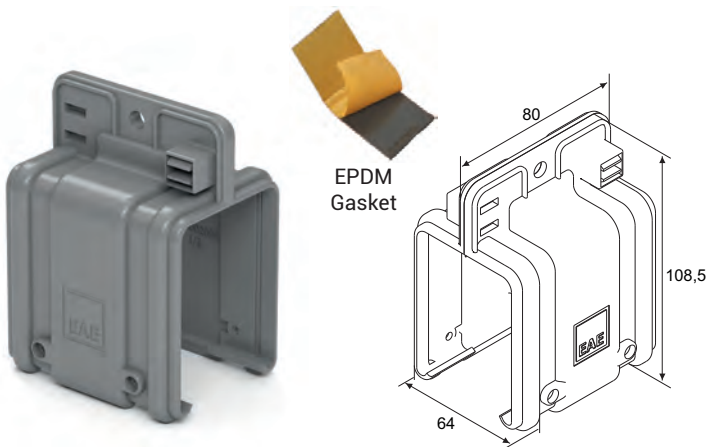

| Description | Weight (gr) | Order Code |
|----------------|-------------|------------|
| TBS Joint Unit | 90 | 1003663 |

TB Housing Pin

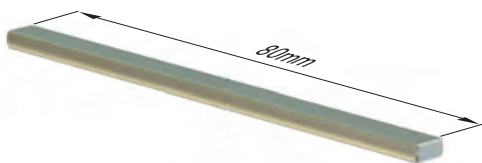

• Two pieces should be used with each joint unit

| Description | Weight (gr) | Order Code |
|----------------|-------------|------------|
| TB Housing Pin | 8 | 1001025 |

TBS End Closure

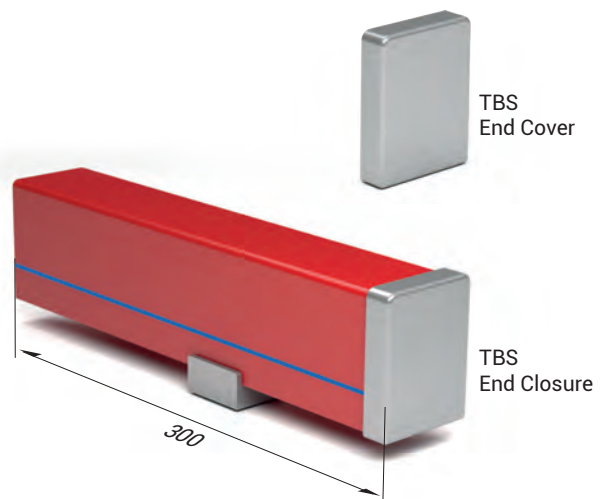

The end closure placed on the end of the busbar line prevents the exposure of the conductors, protects the system, and prevents the current collector from moving out of the housing.

| Description | Weight (gr) | Order Code |
|-----------------|-------------|------------|
| TBS End Closure | 450 | 3024419 |
| TBS End Cover | 25 | 1003109 |

E-LINE TBS



TBS Line Feed Units - Continuous Type

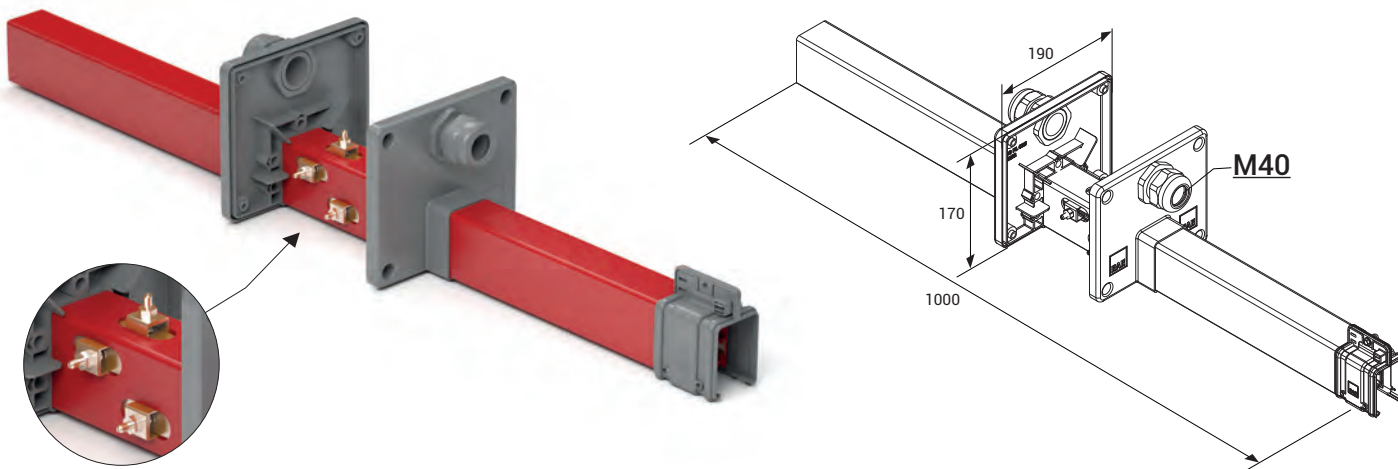

| Description | Weight (gr) | Order Code |
|--------------------------------------|-------------|------------|
| TBS Line Feed Unit - Continuous Type | 2350 | 3024458 |

Type of the feeding element is selected by calculating the voltage drop and the location of the power supply that shall provide power to the system.

TBS Line Feed Units - Jointed Type

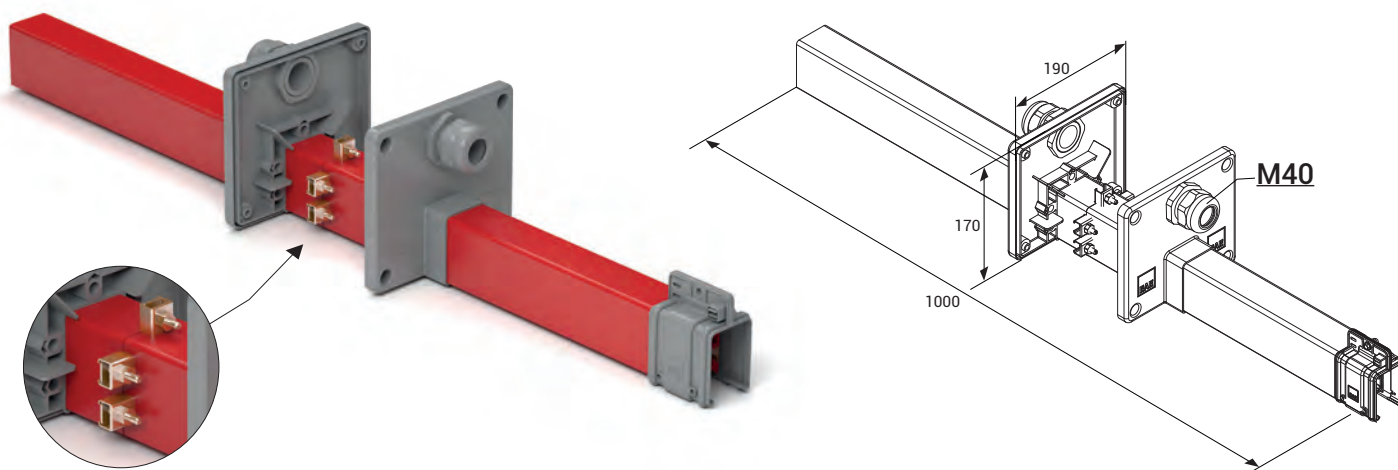

| Description | Weight (gr) | Order Code |
|-----------------------------------|-------------|------------|
| TBS Line Feed Unit - Jointed Type | 2450 | 3024472 |

Type of the feeding element is selected by calculating the voltage drop and the location of the power supply that shall provide power to the system.

TBS Repair Zone Unit

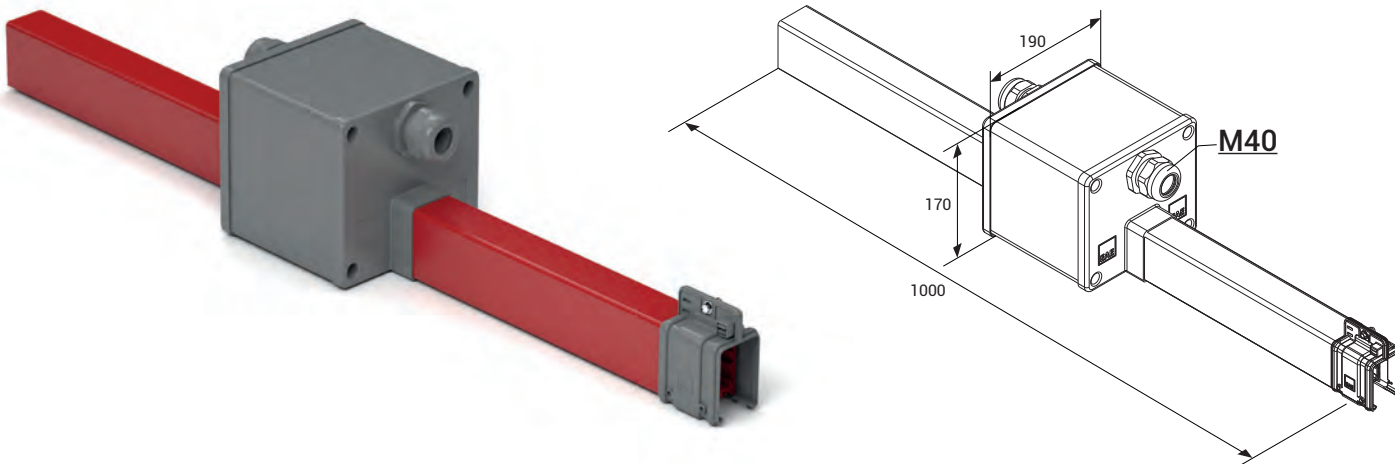

| Description | Weight (gr) | Order Code |
|------------------------|-------------|------------|
| TBS Repair Zone Module | 2550 | 3066696 |

Current supply shall be cut off when a machine working on the line shall be maintained or repaired. Repair zone module is used to create a currentless area on the busbar so that the other machines operating on the same line may continue to work.

TBS Current Collector Replacement Module

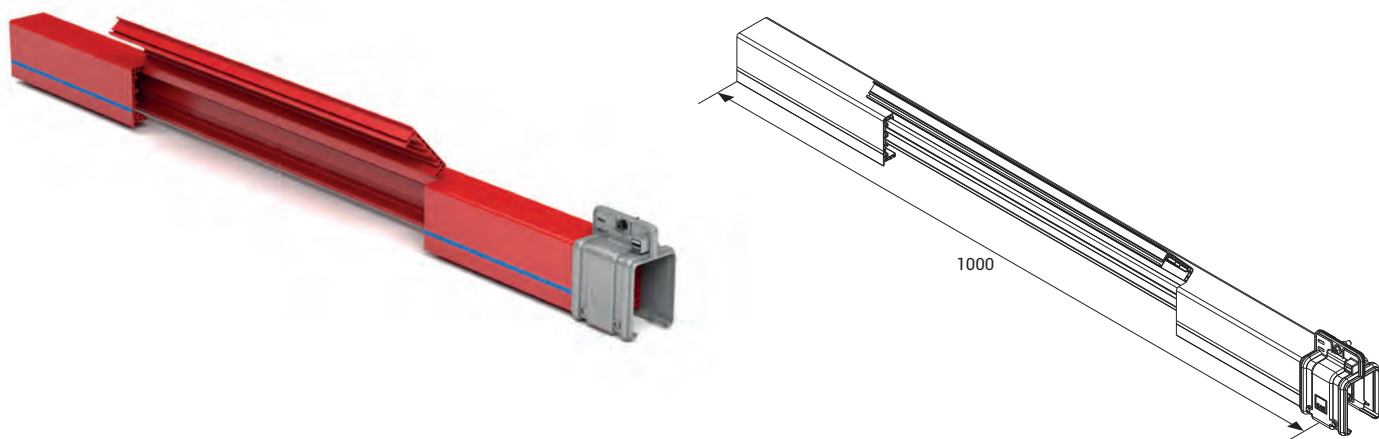

| Description | Weight (gr) | Order Code |
|--|-------------|------------|
| TBS Current Collector Replacement Module | 1500 | 3024471 |

This unit is used to remove an existing current collector or to add extra trolleys. The unit is obtained by cutting a 50cm section from the PVC housing.

TB5 Current Collectors With Cable

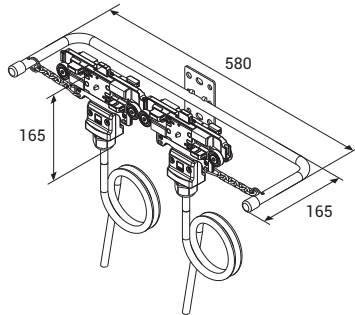
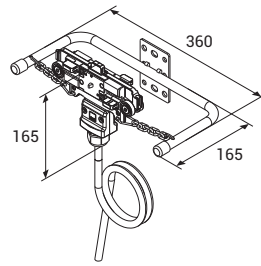

| Model | Brushes Number-Current (A) | Weight (gr) | Order Code |
|-------|----------------------------|-------------|------------|
| TB5 | 4P - 35A (Single) | 1700 | 3024385 |
| | 4P - 70A (Double) | 2950 | 3024386 |
| | 4P - 105A (Triple) | 4450 | 3024387 |
| | 5P - 35A (Single) | 1900 | 3024376 |
| | 5P - 70A (Double) | 3250 | 3024377 |
| | 5P - 105A (Triple) | 4700 | 3024378 |

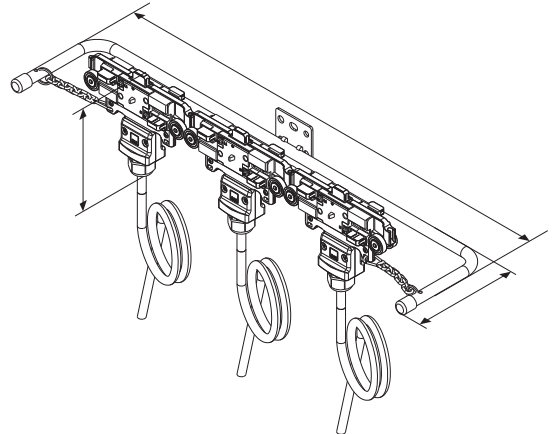

| Model | Brushes Number-Current (A) | Weight (gr) | Order Code |
|-------|----------------------------|-------------|------------|
| TB5 | 4P - 60A (Single) | 2000 | 3203193 |
| | 4P - 120A (Double) | 3550 | 3269558 |
| | 5P - 60A (Single) | 2200 | 3203194 |
| | 5P - 120A (Double) | 3850 | 3269559 |

TB5 Current Collectors With Clip

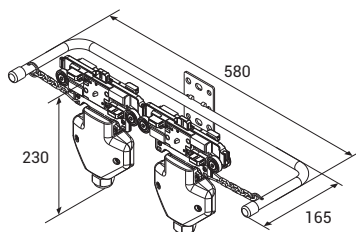
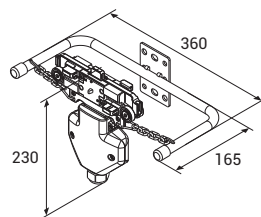
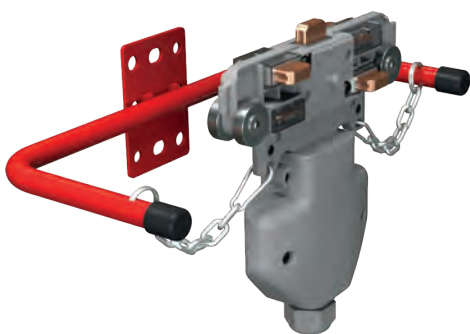

| Model | Brushes Number-Current (A) | Weight (gr) | Order Code |
|-------|----------------------------|-------------|------------|
| TB5 | 4P - 35A (Single) | 1350 | 3024388 |
| | 4P - 70A (Double) | 2050 | 3024389 |
| | 4P - 105A (Triple) | 3050 | 3024390 |
| | 5P - 35A (Single) | 1350 | 3024379 |
| | 5P - 70A (Double) | 2250 | 3024380 |
| | 5P - 105A (Triple) | 3200 | 3024381 |

*Produced with standard M40 cable gland and 4mm² clip.

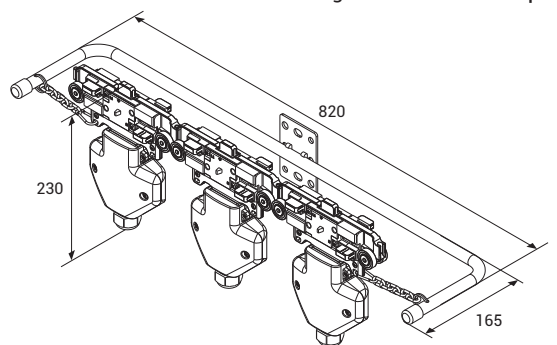

Current collector with clips allow the customers to perform cabling as they desire with the clips they include.

Current collector are the moving elements of the trolley busbar systems. Current collector brushes rub against the conductors and draw continuous current while they move through the busbar line. They adapt to shaky and vibrant conditions thanks to the moving brushes. As current collecting and transfer systems are included in the C-PVC housing, they are protected against human contact.

TB5 Current Collector With Fuse Box

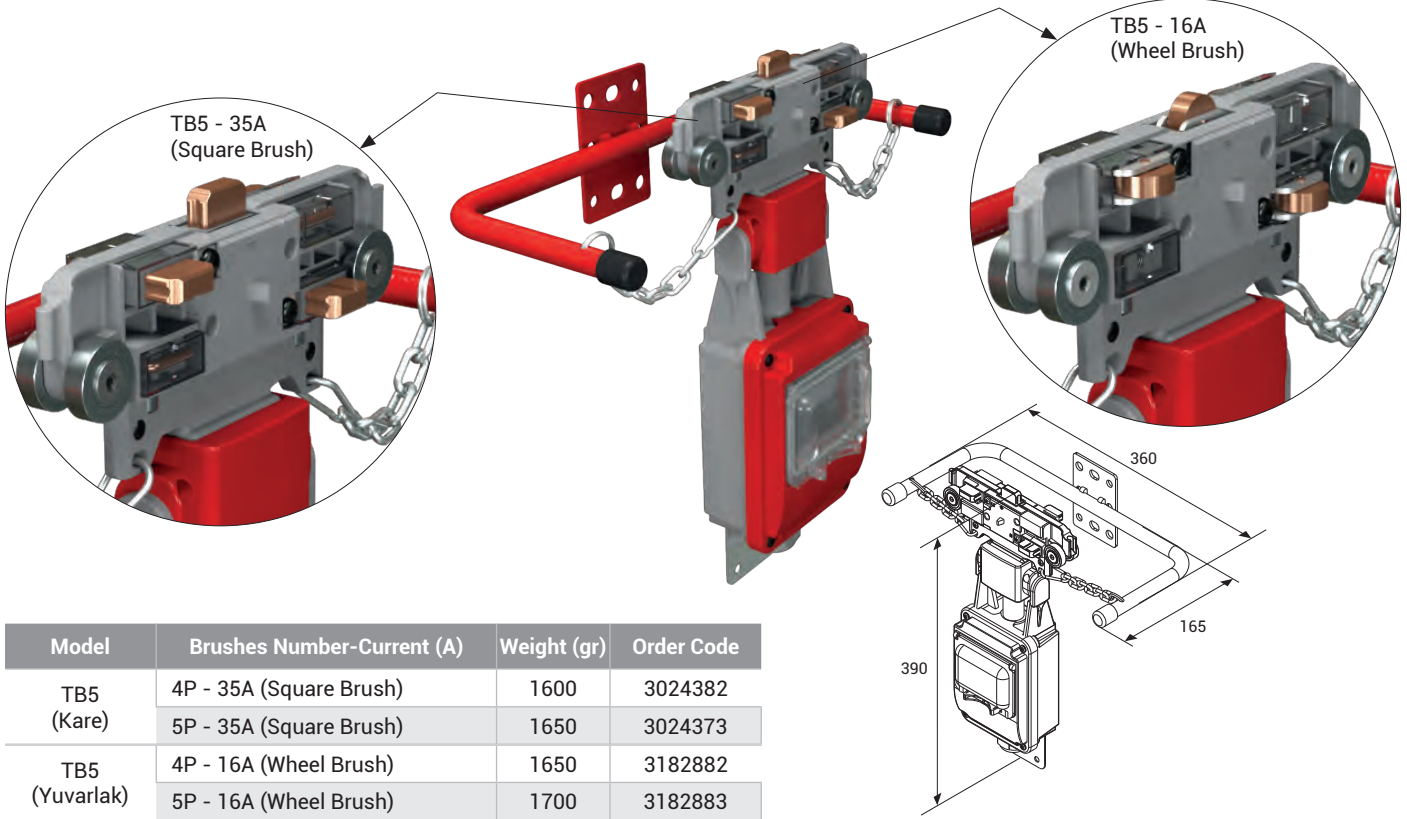

| Model | Brushes Number-Current (A) | Weight (gr) | Order Code |
|----------------|----------------------------|-------------|------------|
| TB5 (Kare) | 4P - 35A (Square Brush) | 1600 | 3024382 |
| | 5P - 35A (Square Brush) | 1650 | 3024373 |
| TB5 (Yuvarlak) | 4P - 16A (Wheel Brush) | 1650 | 3182882 |
| | 5P - 16A (Wheel Brush) | 1700 | 3182883 |

Fuse boxed with both staff and current receiving area carts current machine's safety can be raised to a higher level. In addition, when it is desired to cut the power of one of the machines on a line, the current is cut off through the fuse, other machines on the line can continue to operate.

Current collector with Wheel Brush simplify the movement of the current collectors inside the busbar by reducing the time at the installation tables when movement is provided by the personnel.

TB5 Current collector models operating speed is max. 100m/min.

TB5 Current Collector Brushes

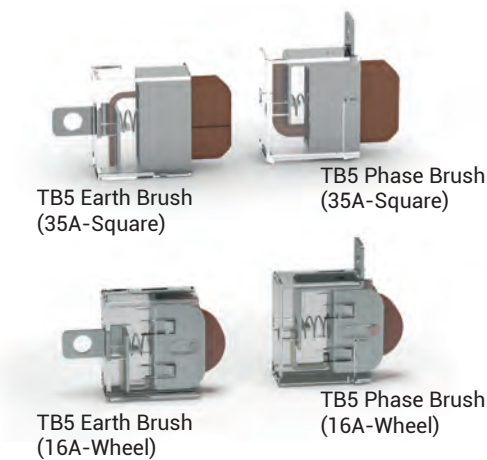

| Description | Weight (gr) | Order Code |
|------------------------------|-------------|------------|
| TB5 Phase Brush (35A-Square) | 40 | 3024371 |
| TB5 Earth Brush (35A-Square) | 40 | 3024372 |
| TB5 Phase Brush (16A-Wheel) | 40 | 3165078 |
| TB5 Earth Brush (16A-Wheel) | 40 | 3165080 |

TB5 Trolley Transfer Tool

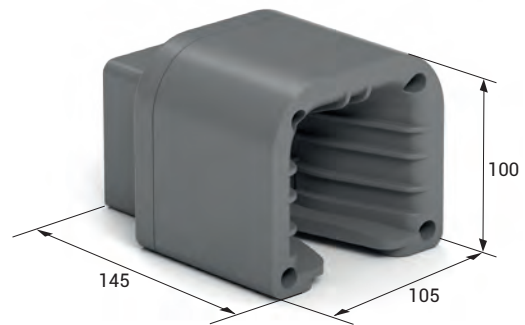

| Description | Weight (gr) | Order Code |
|---------------------------|-------------|------------|
| TB5 Trolley Transfer Tool | 250 | 3179189 |

E-LINE TBS



TB5 Plastic Sliding Hanger

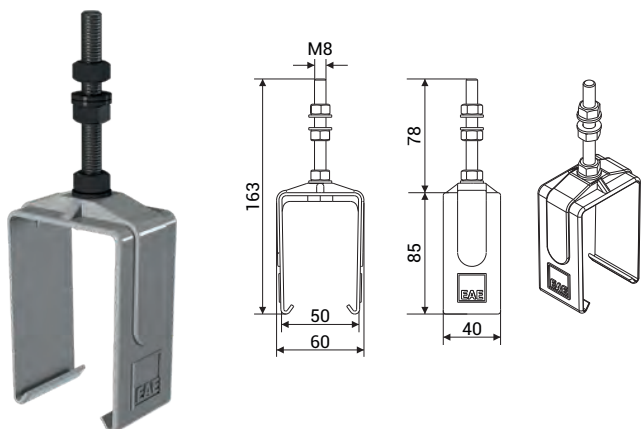

TB5 Steel Sliding Hanger

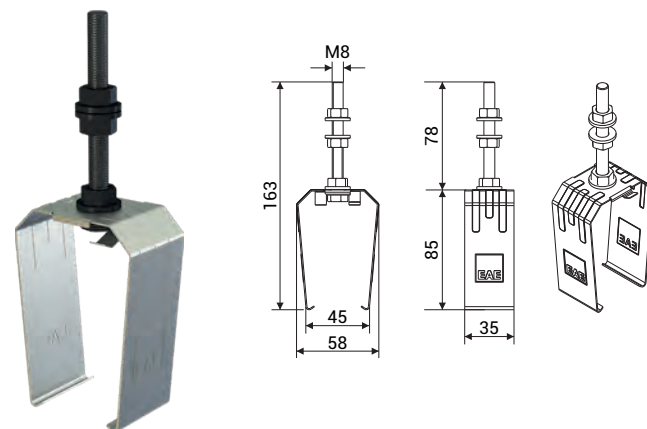

Trolley busbar should be mounted with sliding hangers and each hangers should be between 1,30m - 1,50m. Distance between sliding hanger and other units (joint unit, feeder etc.) should be minimum 300mm.

| Description | Weight (gr) | Order Code |
|----------------------------|-------------|------------|
| TB5 Plastic Sliding Hanger | 85 | 1003664 |

| Description | Weight (gr) | Order Code |
|--------------------------|-------------|------------|
| TB5 Steel Sliding Hanger | 100 | 1005954 |

TB Hanger Bracket

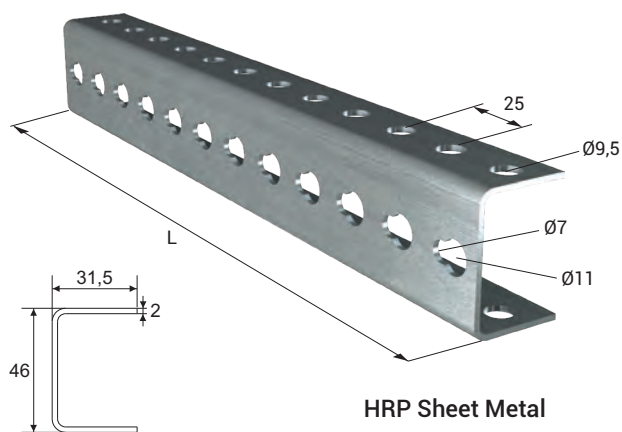

HRP Sheet Metal

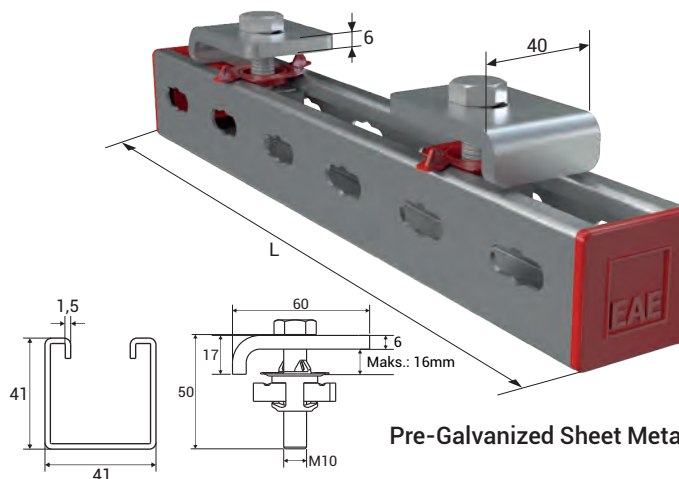

Pre-Galvanized Sheet Metal

| Description | L (mm) | Weight (gr) | Order Code |
|------------------------|--------|-------------|------------|
| TB Hanger Bracket | 250 | 350 | 3025153 |
| URC-C/S Hanger Bracket | 500 | 700 | 3034560 |
| URC-A Hanger Bracket | 750 | 1050 | 3025382 |

| Description | L (mm) | Weight (gr) | Order Code |
|-------------------------------|--------|-------------|------------|
| TB BR Hanger Bracket Set | 300 | 800 | 3178916 |
| URC-C/S BR Hanger Bracket Set | 600 | 1250 | 3178917 |
| URC-A BR Hanger Bracket Set | 800 | 1550 | 3178918 |

• Please browse the MFIX catalog to see our various support solutions.

TB5 Extension Element



When the busbar line needs to be extended, you may remove the End Closure and install the joint unit to extend.

| Description | Weight (gr) | Order Code |
|-----------------------|-------------|------------|
| TB5 Extension Element | 250 | 3141724 |

E-LINE TBS



TB5 Current Collector Brushes

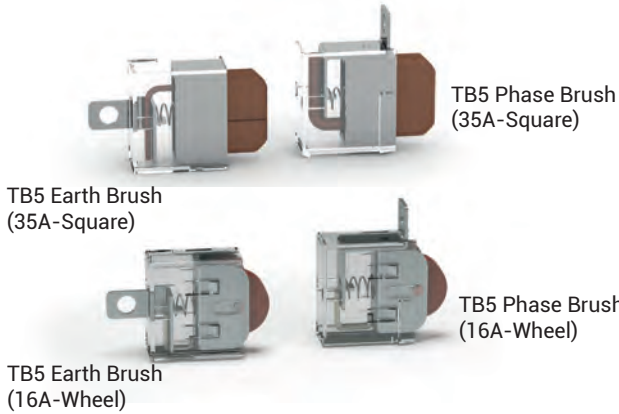

| Description | Weight (gr) | Order Code |
|------------------------------|-------------|------------|
| TB5 Phase Brush (35A-Square) | 40 | 3024371 |
| TB5 Earth Brush (35A-Square) | 40 | 3024372 |
| TB5 Phase Brush (16A-Wheel) | 40 | 3165078 |
| TB5 Earth Brush (16A-Wheel) | 40 | 3165080 |

TB Conductor Cassette



Conductor cassette shall be used to prevent damage to the conductors while the copper conductors are installed on the busbar.

| Description | Weight (gr) | Order Code |
|--------------------|-------------|------------|
| TB Conductor Caset | 6800 | 3025151 |

TBS Gasket



- Continuous length is maximum 300 meters.
- Gasket should be ordered twice the line length.

| Description | Weight (gr/m) | Order Code |
|---------------------|---------------|------------|
| TBS Gasket Roll (m) | 30 | 1037761 |

TB5 Copper Conductors



| Description (mm x mm) | Order Code |
|------------------------------------|------------|
| TB5 0.80x16,00 (TB5 Copper) | 1003097 |
| TB5 1.00x16,00 (TB5 Copper - 75A) | 1002254 |
| TB5 1.50x16,00 (TB5 Copper - 105A) | 1002275 |
| TB5 2.00x16,00 (TB5 Copper - 130A) | 1003094 |

TB5 Conductor Mounting Tool



| Description | Weight (gr) | Order Code |
|-----------------------------|-------------|------------|
| TB5 Conductor Mounting Tool | 215 | 3024456 |

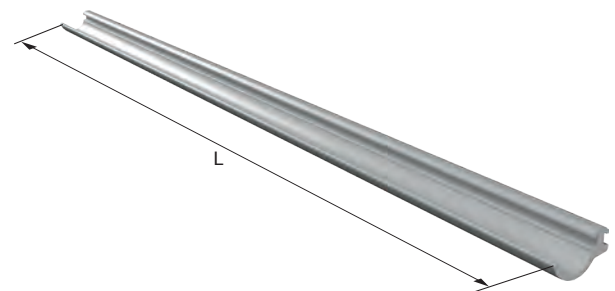

| Description | L (mm) | Weight (gr) | Order Code |
|-----------------------------------|--------|-------------|------------|
| TBS Gasket Straight Length (Pcs.) | 4000 | 120 | 1037762 |

Voltage Drop

The voltage drop in the busbar lines shall be inspected as per the busbar type selected according to the total current calculated based on the ambient temperature and operating period of the system. Maximum acceptable value for voltage drop is 3%.

For Direct Current

$$\Delta U = 2 \cdot L_t \cdot I_G \cdot R$$

ΔU = Voltage Drop [V]

For Mono-Phase Alternative Current

$$\Delta U = 2 \cdot L_t \cdot I_G \cdot Z$$

I_G = Total current [A]

R = Resistance of the busbar [Ω/m]

For Three-Phase Alternative Current

$$\Delta U = \sqrt{3} \cdot L_t \cdot I_G \cdot Z$$

Z = Impedance of the busbar [Ω/m]

L_t = Calculated Hole Length [m]

Note : Calculation of the current drawn during first start in various motor types;

I_A = Total current drawn in the first start of the motors [A]

For the starting current; Three-phase asynchronous drive in direct start

I_A = I_G x calculated as 5 to 6

Slip ring rotor motor

I_A = I_G x calculated as 2 to 3

Frequency converter

I_A = I_G x 1,20 to 1,50 calculated between.

Calculation Of Feeding Points

When we take L_t as the length of the line, feeding points may be selected as shown in the diagrams below to keep the L voltage drop at minimum and it may be used as the hole length for the calculation of L_t voltage drop.



1 feeding point from the start, $L_t=L$

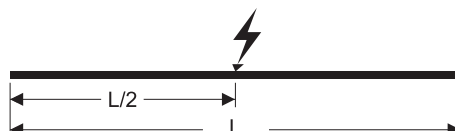

1 feeding point from the center, $L_t=L/2$



2 feeding points from the start points, $L_t=L/4$



2 feeding points, $L_t=L/6$

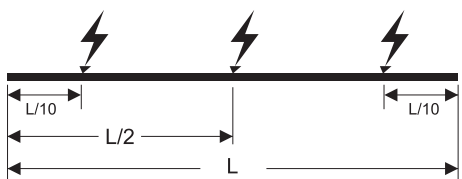

3 feeding points, $L_t=L/10$

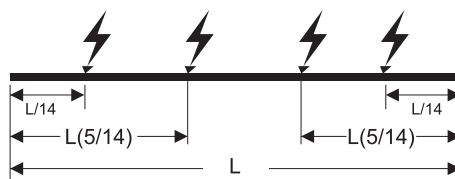

4 feeding points, $L_t=L/14$

E-LINE TBS

Installation Manual

TBS - Installation Of Joint Unit

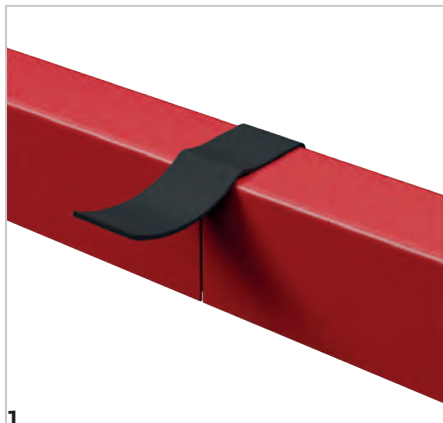

1
The joint point is covered using a self-adhesive EPDM gasket.

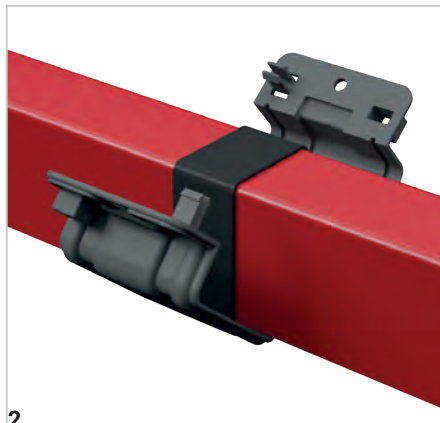

2
Engage the joint unit to the bottom of the busbar and close it.

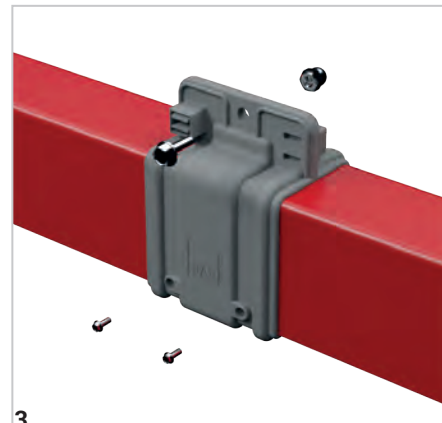

3
Close the joint cover and screw it.

TBS - Feeder Unit

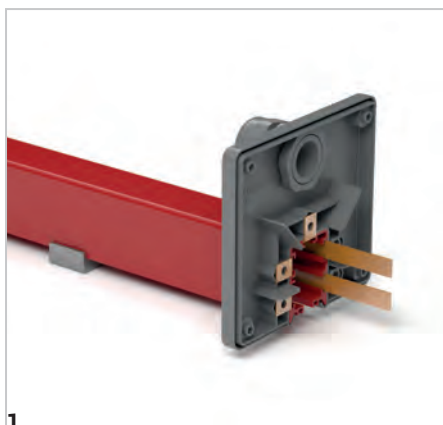

1
Conductors are bend 90° and pushed into the housing.

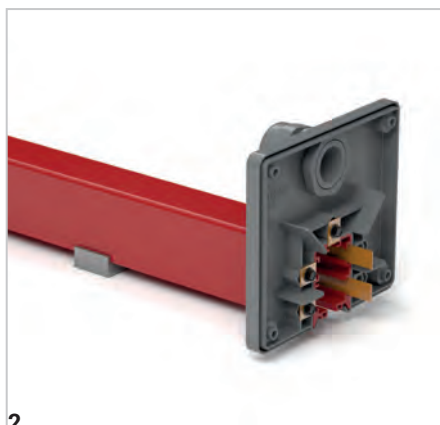

2
Housing and screw them to the feeding module.

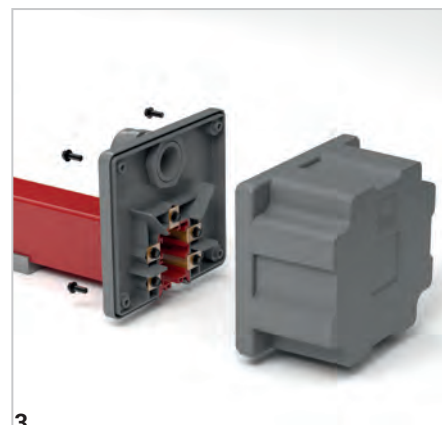

3
Close the module cover and screw it.

TBS

TBS - Line Feed Unit - 2 (Jointed Type)

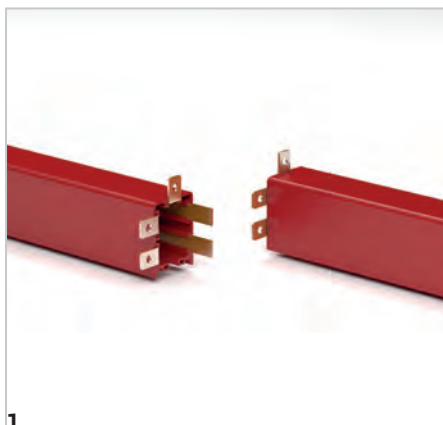

1
Bend conductors for 90°, and push them inside the housing.



2
Put conductors back-to-back and join them with clips. Connect the feeding cables to the clips.

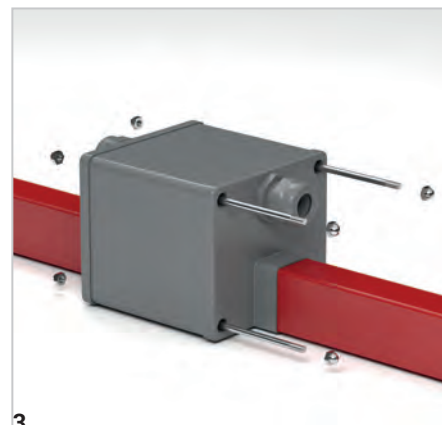

3
Close the module cover and screw it.

E-LINE TBS

Installation Manual

TBS - Line Feed Unit - 1 (Continuous Type)

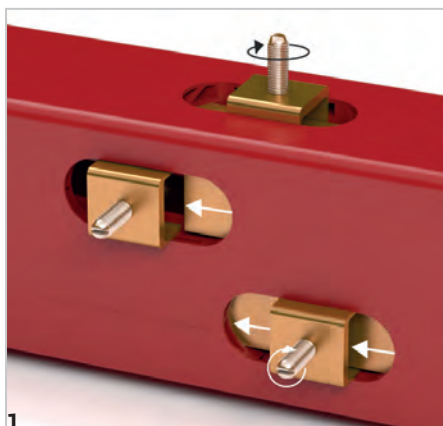

1 Put the conductors through the clips and screw them.

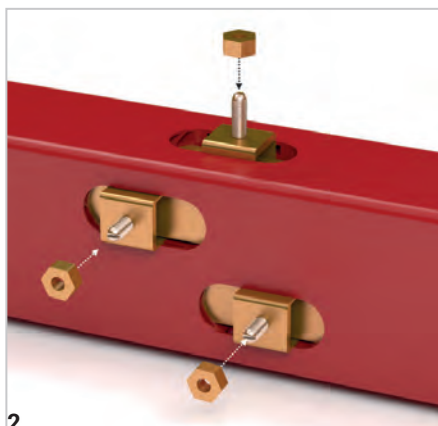

2 Connect the feeding cables to the clips with nuts.

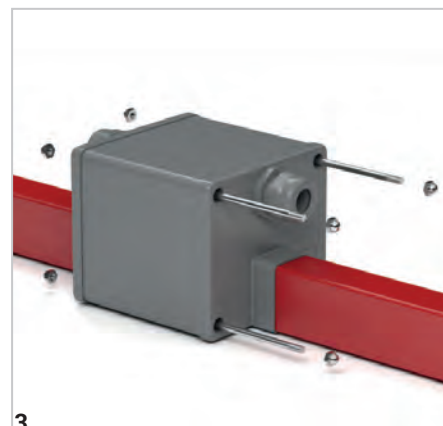

3 Close the module cover and screw it.

TBS - End Closure

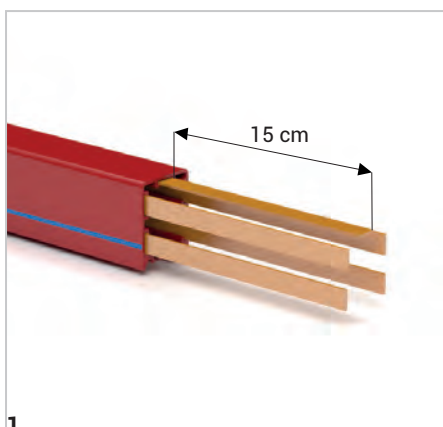

1 Cut the coppers at the end of the line by leaving a extra length of 15 cm.

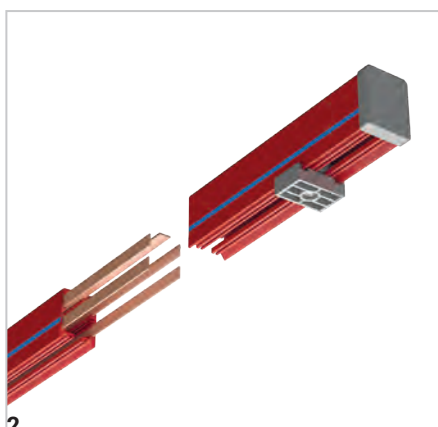

2 After placing the current collector to the system, place the End Closure so that it shall house the coppers.

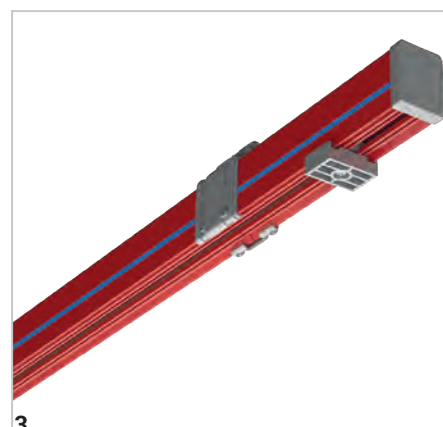

3 Install it on the system as you do while installing the extension.

TBS - Conductor Mounting Tool

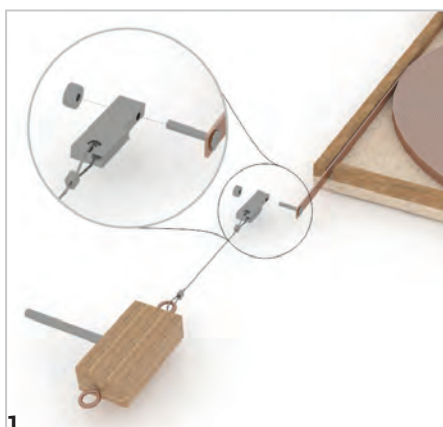

1 Screw the conductor to the conductor mounting tool.

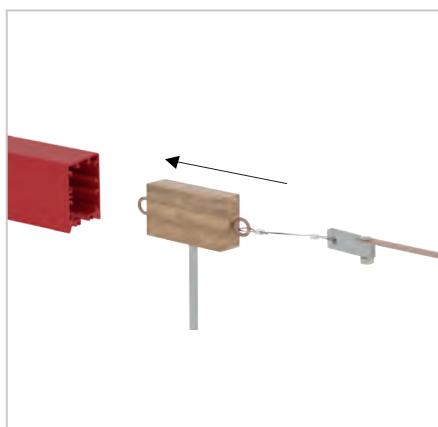

2 Drive the conductor mounting tool along the line.

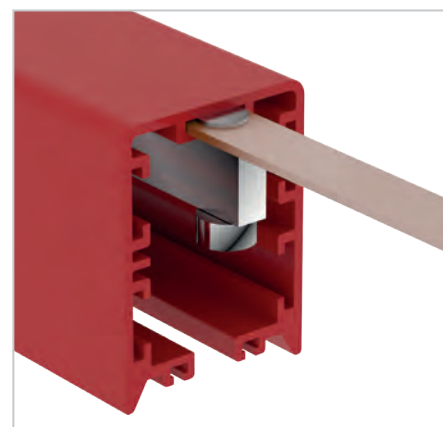

3 Ensure that the conductor is seated.

E-LINE TBS

Offer Request Form



Date :

| | | |
|--------------|---|----------------------|
| Project Name | : | <input type="text"/> |
| Company | : | <input type="text"/> |
| Name Surname | : | <input type="text"/> |
| Tel | : | <input type="text"/> |
| E-Mail | : | <input type="text"/> |
| Address | : | <input type="text"/> |

General Data

| | | |
|---------------------------|---|----------------------|
| Track Length | : | <input type="text"/> |
| Number of Cranes on Track | : | <input type="text"/> |
| Crane Travel Speed | : | <input type="text"/> |

Environmental Data

| | | | |
|--|---|---------------------------------|----------------------------------|
| Operating Environment | : | <input type="checkbox"/> Indoor | <input type="checkbox"/> Outdoor |
| Ambient Temperature | : | <input type="text"/> °C min. | <input type="text"/> °C max. |
| Other Operating Conditions (Humidity, Dust, Chemical Influence, etc.) | : | <input type="text"/> | |

Electrical Data

| | | | | | | | |
|-------------------------------|---|-------------------------------|----------------------------------|------------------------------|------------------------------|------------------------------|-------------------------------|
| Operating Voltage | : | <input type="text"/> Volts | <input type="checkbox"/> AC | <input type="checkbox"/> DC | | | |
| | | <input type="text"/> Phases | <input type="checkbox"/> N | <input type="checkbox"/> PE | | | |
| Position and Number of Feeder | : | <input type="text"/> from End | <input type="text"/> from Middle | | | | |
| Duty Cycle (%) | : | <input type="checkbox"/> 50% | <input type="checkbox"/> 60% | <input type="checkbox"/> 70% | <input type="checkbox"/> 80% | <input type="checkbox"/> 90% | <input type="checkbox"/> 100% |

| Motor Specifications | Crane - 1 | | Crane - 2 | | Crane - 3 | |
|----------------------|----------------------|----------------------|----------------------|----------------------|----------------------|----------------------|
| | Power (kW) | Current (A) | Power (kW) | Current (A) | Power (kW) | Current (A) |
| Hoist motors | <input type="text"/> | <input type="text"/> | <input type="text"/> | <input type="text"/> | <input type="text"/> | <input type="text"/> |
| Auxiliary motor | <input type="text"/> | <input type="text"/> | <input type="text"/> | <input type="text"/> | <input type="text"/> | <input type="text"/> |
| Long travel | <input type="text"/> | <input type="text"/> | <input type="text"/> | <input type="text"/> | <input type="text"/> | <input type="text"/> |
| Cross travel | <input type="text"/> | <input type="text"/> | <input type="text"/> | <input type="text"/> | <input type="text"/> | <input type="text"/> |

Options

| | | | |
|---------------------------------|---|------------------------------|-----------------------------|
| Brackets Required | : | <input type="checkbox"/> Yes | <input type="checkbox"/> No |
| Repair Zone Required | : | <input type="checkbox"/> Yes | <input type="checkbox"/> No |
| | | <input type="text"/> Qty | |
| Collector Replacement Required: | | <input type="checkbox"/> Yes | <input type="checkbox"/> No |
| | | <input type="text"/> Qty | |
| Descriptions | : | <input type="text"/> | |

Please duplicate this page for your own use.

DECLARATION

CE DECLARATION OF CONFORMITY

Product Group E-Line TB Trolley Busbar Systems
Manufacturer Akcaburgaz Mahallesi, 3114. Sokak,
No:10 34522 Esenyurt-Istanbul

The objects of the declaration described below is in conformity with the relevant Cable gland harmonisation legislation. This declaration of conformity is issued under the sole responsibility of the manufacturer.

Standard:

TS EN 61439-6

Low-voltage switchgear and controlgear assemblies - Part 6: Busbar trunking systems

CE - Directive:

2014/35/EU "The Low Voltage Directive"

2014/30/EU "(EMC) Electromagnetic Compatibility Directive"

2011/65/EU "RoHS Directive"

Technical Document Preparation Official:

EAE Elektrik Asansor End. Insaat San. Tic. A.S.
Akcaburgaz Mahallesi, 3114. Sokak, No:10 34522 Esenyurt-Istanbul

Mustafa AKÇELİK

Date

20.03.2026

Document Authorized Signatory

Elif Gamze KAYA OK
Deputy General Manager



SUSTAINABLE FUTURE

Sustainability Management at EAE Elektrik



As part of our goal to support sustainable development and green transformation, measuring, evaluating, and managing all economic, environmental, and social impacts resulting from our sustainability practices is a key governance priority for EAE Elektrik. We act with great care in analyzing, monitoring, and managing the economic, environmental, and social impacts and risks that arise throughout our value chain in both our national and global operations.

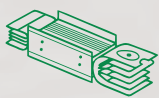

Busbar Systems

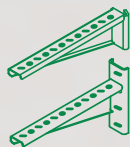

Support Systems

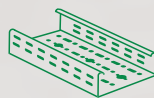

Cable Tray Systems

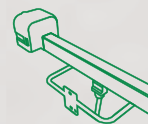

Trolley Busbar Systems



Fit-Out Solutions

"We are working together with all our stakeholders to develop the electrical technologies that will build the future."

You can visit our sustainability website at sustainability.eaeelectric.com



#FutureTogether

EAE Elektrik
Head Office

Akcaburgaz Mahallesi,
3114. Sokak, No: 10 34522
Esenyurt - Istanbul - Turkiye
Tel: +90 (212) 866 20 00
Fax: +90 (212) 886 24 20

EAE DL 4 Factory
Busbar 2

Organize Sanayi Bolgesi Mahallesi,
6. Cadde, No: 14/10, 41455
Dilovasi - Kocaeli - Turkiye
Tel: +90 (262) 999 05 55
Fax: +90 (262) 502 01 45



Please visit our website for the updated
version of our catalogues.
www.eaelectric.com



Catalogue 08 - En. / Rev. 16 0 Pcs. 25/05/2026
E.U.

EAE has full right to make any revisions or changes on this catalogue without any prior notice.