

# E-LINE KO-II

Busbar Systems 160A...800A

# EAE GROUP IN NUMBERS



## Since 1973

EAE Group of Companies started its journey in the electrical sector in 1973 with the establishment of EAE Elektrik. Since its founding, EAE has grown rapidly, expanding its production and areas of operation by incorporating EAE Lighting in 1983, EAE Machinery in 1996, EAE Electrotechnics in 2004, and EAE Technology in 2009.

EAE carries out its production activities in accordance with ISO 9001 Quality Management, ISO 14001 Environmental Management, ISO 14064-1 Greenhouse Gas Management System, ISO 45001 Occupational Health and Safety Management, ISO 10002 Customer Satisfaction Management, ISO 50001 Energy Management System, and ISO 27001 Information Security Management System standards.



**50+**  
Years Experience



**8**  
Active Factories



**370.000m<sup>2</sup>**  
Enclosed Space



**3**  
R&D Centers



**150+**  
Countries Exported To

# CONTENTS

---

Introduction .....	2-3
Design .....	4
Order Code System .....	5
Technical Characteristics .....	6
Standard Components .....	7
Elbows .....	8-11
Standard Components .....	12-13
Feeder Boxes .....	14-16
Selection Of Feeder Boxes .....	17
Panel Connections .....	18
Tap-off Boxes .....	19-22
Fixing Elements .....	23-25
Vertical and Horizontal Busbar Applications .....	26-27
Expansion Modules Application .....	28
Fire Barrier / Determination of Special Length .....	29
Installation of End Closer / Mounting Instructions for Joints .....	30
EC Declaration Of Conformity .....	31
Certificates .....	32
Product Overview .....	33
Project Design Form .....	34-36

# E-LINE KO-II

## Introduction

**E-Line KO-II Busbar System** distributes electrical power, both vertically and horizontally at premises where there is a need for electrical power 160 A and 800 A.

It provides a prefabricated and flexible electrical distribution system for all factories engaged in mass production, like automobile plants, textile plants, furniture factories and for buildings where there is a need for a reliable power supply such as business centres, hotels, hospitals, warehouses and all high rise buildings.

### • Fast, Flexible Engineering

The large number tap-off points makes it possible to engineer the power supply systems at an early stage, even before the final distribution of loads is known.

### • Fast and Easy Mounting

Power is easily supplied to machines by E-Line KO-II. The installation of the system does not require any expertise. Supports and accessories are available for mounting the system either from the ceiling or the wall.

### • Safe Power Distribution and Transportation

E-Line Busbar Systems increase personnel safety by their special features.

### • Lower Total Installed Cost

Total Busbar material and installation costs are often equal to or less than cable and conduit.

### • Flexible Power Supply

Tap-off points at short intervals make electrical power available in all locations, the power supply can be adapted to different production processes simply by relocating the tap-off units. Being built up of basic elements, it can at any time be extended, modified, dismantled and re-used.

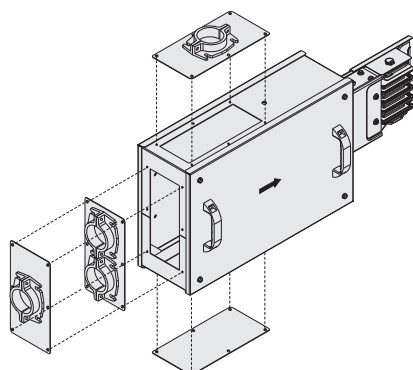

### • Safe Power Take Off

The earth of the tap-off box makes contact with the busbar first and ensures the safety, of the box and the system that's been fed.

### • Modern Appearance

Other than its functional advantages E-Line KO-II busbar system also creates a modern appearance in buildings where it is used.

### • Lower Life Cycle Cost

Busbar components can be added, removed or relocated after the initial installation, saving time and money.

### • Tap-off Points

Power can only be supplied by E-Line KO-II tap-off boxes. Where necessary the unused tap-off points can be restricted by sealing. Dust covers protect the system from any accidental contact and also prevents the ingress of pollutants from the environment.

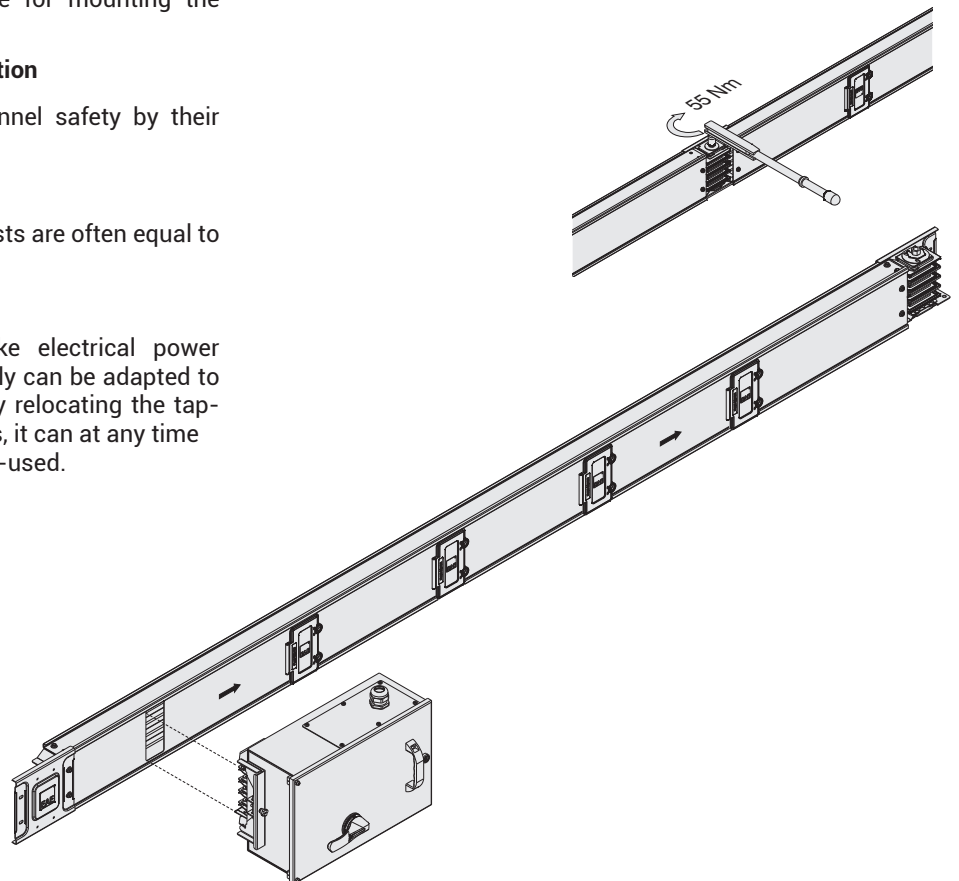

### • Conductors

- Copper and Aluminium conductors are tin plated along their length.

- Cross-section of neutral conductor is the same as the phase conductors.

- Upon request the KO-II range can also be manufactured with 5 conductors.

• "One Bolt Joint"

E-Line KO-II Busbars are easily installed by tightening the "one bolt joint". Belleville spring washers on both ends of the bolt retains the original contact pressure ensuring a more secure and reliable joint.

• Tap-off Boxes

Power upto 400A can be supplied by tap-off boxes. Standard tap-off boxes are equipped with an interlock mechanism which prevents the cover of tap-off boxes from being opened before the power is turned off. Tap-off boxes are easily mounted on the busbar without any additional mounting equipment. Tap off boxes are fixed to E-Line KO-II Busbar by integral fixing clamps.

The standard tapoff boxes with fused switches or MCCBs cannot be removed from the busbar with the tap off box on load.

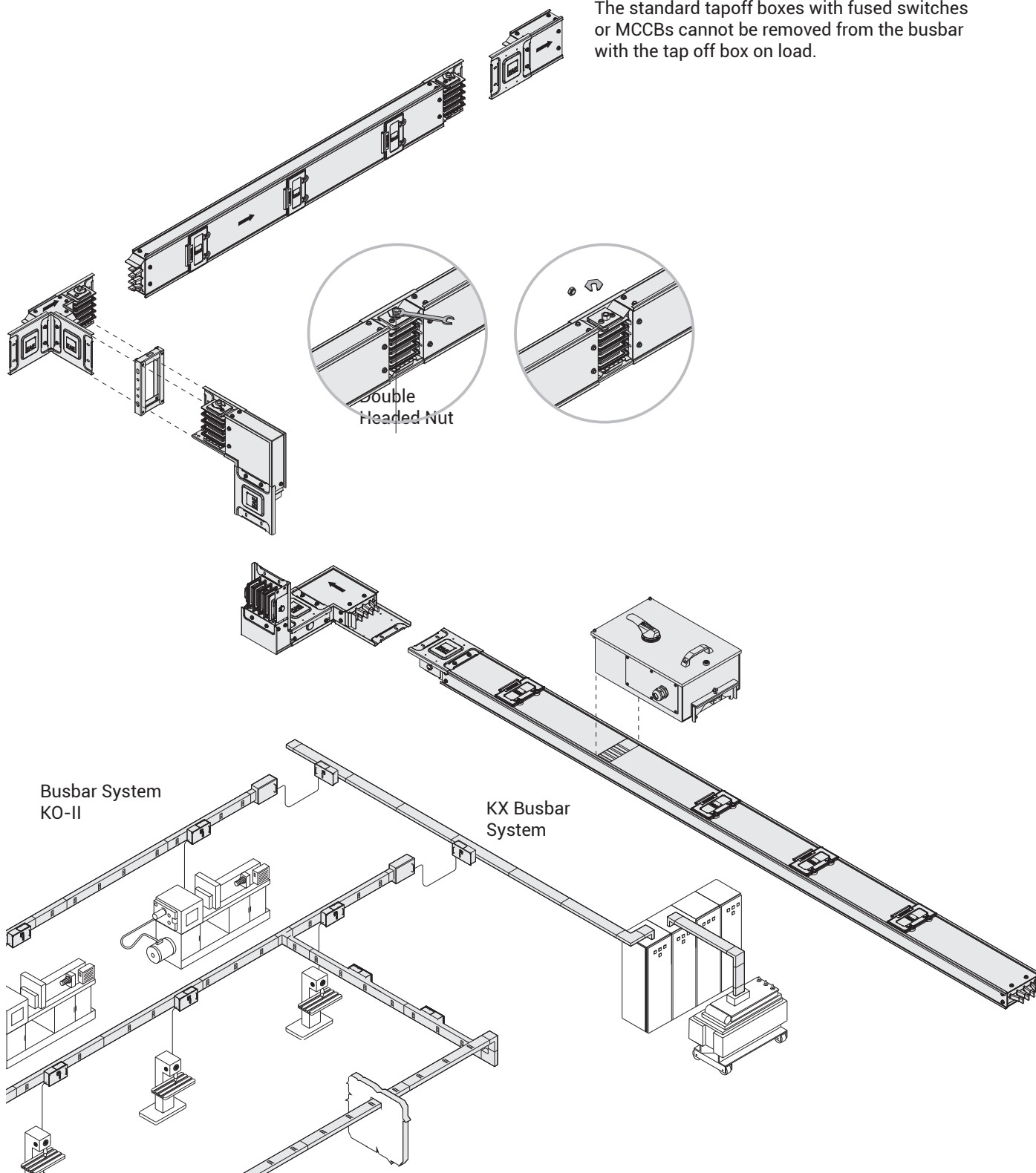

While designing an electrical distribution system with E-Line KO-II a few approximate details will be necessary.

- Location, number, type and approximate ratings of loads,
- Transformer rates and short-circuit capacities,
- Utilization factor =  $\alpha$
- System co-ordination with other distribution systems (heat, water, etc.)
- Determining the route of E-Line KO-II on layouts,
- Deciding on suitable supports,
- If necessary, co-ordination of E-Line KX, E-Line MK, E-Line KAM-KAP and E-Line KY with E-Line KO-II runs.

### Rated Current

The current is calculated using the following equation.

$$I_B = \frac{P \cdot \alpha}{\sqrt{3} \cdot U \cdot \cos \varphi}$$

$I_B$  = Operating Current (A)

$P$  = Installed Load (W)

$\alpha$  = Utilization Factor

$U$  = Supply Voltage

- Busbar Current rating is chosen as equal to or higher than the calculated  $I_B$  current.
- After the voltage drop calculation if the chosen current rating is too low, a higher rating should be selected.

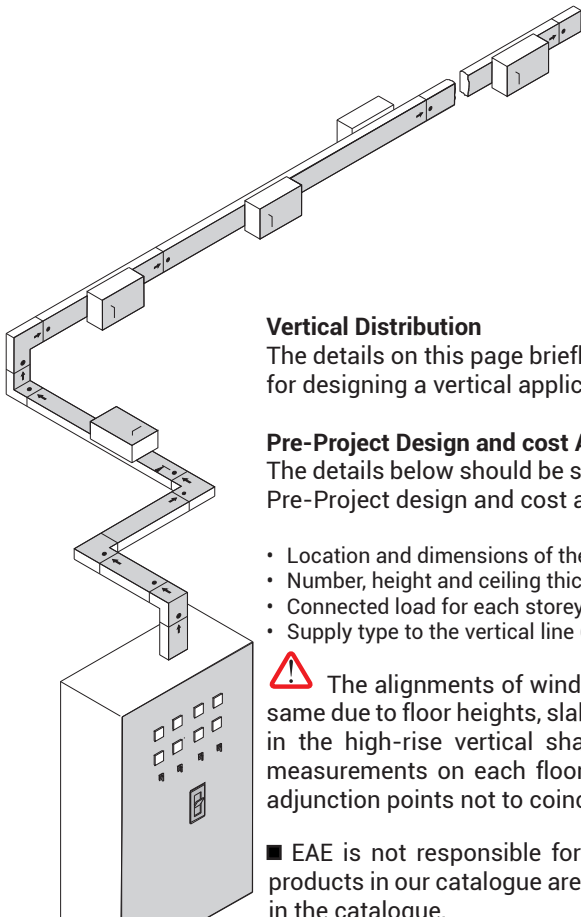

### Vertical Distribution

The details on this page briefly explain the necessary information required for designing a vertical application project.

### Pre-Project Design and cost Analysis

The details below should be sent to our Project and Design Department for Pre-Project design and cost analysis.

- Location and dimensions of the shaft where busbar will be installed,
- Number, height and ceiling thickness of each storey, ( $h=$ )
- Connected load for each storey, ( $a=$ )
- Supply type to the vertical line (Busbar or Cable) ( $p=$ )

The alignments of windows or adjunction points on upper floors may not be the same due to floor heights, slab thickness and product tolerances on multi-way busbars in the high-rise vertical shaft applications. Assembly should continue by making measurements on each floor in order for boxes to be in alignment and in order for adjunction points not to coincide with floor transitions.

■ EAE is not responsible for the potential risks that may occur in cases where the products in our catalogue are used outside of the standard phase sequences as shown in the catalogue.

### Diversity Factor (a)

The diversity factor(a) depends on the type and number of loads.

It is usually around 0.7 or lower. The diversity factor of a line supplying electric motors and lighting systems is usually 0.6 It is as low as 0.5 in welding shops of car factories, (a) can be 1 in lines where only one big load is supplied.

### Applications

As each building's structure is different from another for vertical and horizontal applications special projects have to be designed.

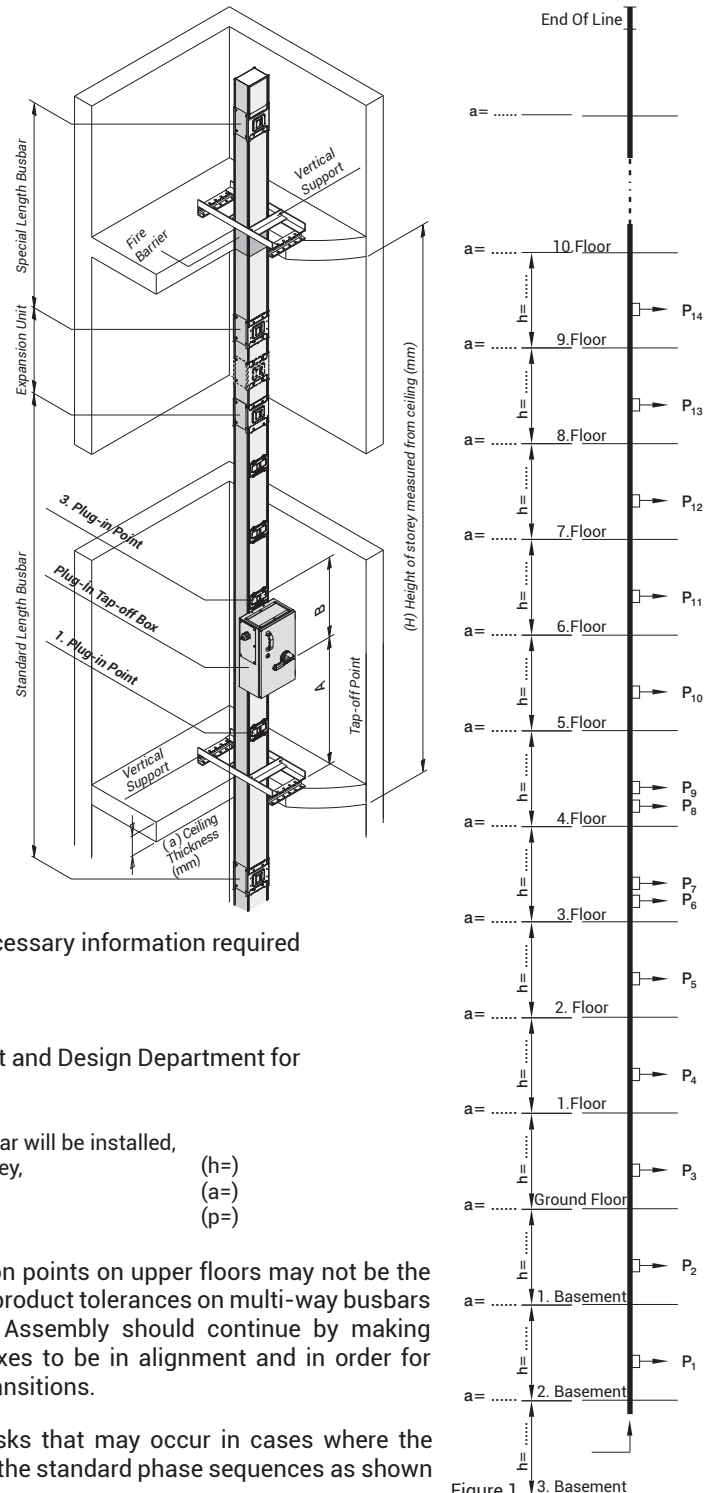

Figure 1

# E-LINE KO-II

## Order Code System



BUSBAR TYPE  
CONDUCTOR TYPE  
BUSBAR CODE  
PROTECTION DEGREE  
CONDUCTOR CONFIGURATION  
UNPAINTED / PAINTED  
COMPONENT

KO A 06 5 5 - II - B - DDT

Busbar Type

Aluminium A  
Copper C

Conductor Type

	Busbar Rated Current	Busbar Code	
Aluminium	160	01	6x20
	250	02	6x25
	315	03	6x30
	400	04	6x50
	500	05	6x62,5
	600	06	6x75
	800	08	6x110
Copper	250	02	6x20
	315	03	6x25
	400	04	6x30
	600	06	6x50
	800	08	6x75

Busbar Code

IP 55 5

Protection Degree

### Components

Plug-in Standard Length	STD
Plug-in Special Length	X
Feeder Standard Length	FTD
Feeder Special Length	FX
Right Elbow	R
Left Elbow	L
Downwards Elbow	D
Upwards Elbow	U
Right Upwards Combined	KRU
Left Upwards Combined	KLU
Right Downwards Combined	KRD
Left Downwards Combined	KLD
Upwards Right Combined	KUR
Upwards Left Combined	KUL
Downwards Right Combined	KDR
Downwards Left Combined	KDL
Upwards Vertical Offset	UV
Downwards Vertical Offset	DV
Right Horizontal Offset	RH
Left Horizontal Offset	LH
"T" Component	T
Cross	DD
Reductions	RD
End Closer	S
Horizontal Expansion	YDT
Vertical Expansion	DDT
Flexible	F
Feeder Box 1	B1
Feeder Box 2	B2
Central Feeder Box 1	B01
Central Feeder Box 2	B02
Panel Connections	P10
Panel Connections	P11

Paint

UNPAINTED -  
PAINTED B

### Conductor Configuration

Number of Conductors	Code	Configuration								
		L1	L2	L3	N	PE	½ PE	CPE	½ CPE	PE (Housing)
4 conductors	4	✓	✓	✓	✓					✓
5 conductors	5	✓	✓	✓	✓	✓				✓
4 ½ conductors	6	✓	✓	✓	✓		✓			✓
5 conductors (CPE)	7	✓	✓	✓	✓			✓		✓
4 ½ conductors (CPE)	9	✓	✓	✓	✓				✓	✓

Rated Current	In	A	Aluminium Conductor (KOA)								Copper Conductor (KOC)				
			160	250	315	400	500	600	800	250	315	400	600	800	
Busbar Code			01	02	03	04	05	06	08	02	03	04	06	08	
Standards	IEC 61439-6, TS EN 61439-6, IEC 61439-1, TS EN 61439-1														
Rated Insulation Voltage	Ui	V	1000												
Max. Rated Operational Voltage	Ue	V	1000												
Rated Frequency	f	Hz	50												
Pollution Degree	3														
Protection Degree	IP	55													
External Mechanical Impacts (IK Code)	Plug-in Busbar IK09														
Protection for Safety	Basic protection (HD 60364-4-41, clause A1)														
Rated Short-time Withstand Current (1s)	$I_{cw}$	$kA_{(rms)}$	10	15	15	30	30	35	35	18	18	25	35	35	
Rated Peak Withstand Current	$I_{pk}$	kA	17	30	30	63,5	63,5	73,5	73,5	36	36	52,5	73,5	73,5	
Rated Short-time withstand Current (N) (1s)	$I_{cw}$	kA	6	9	9	18	18	21	21	10,8	10,8	15	21	21	
Rated Peak Withstand Current (N)	$I_{pk}$	kA	10,2	15,3	15,3	36	36	44,1	44,1	21,6	21,6	30	44,1	44,1	
Rated Short-time withstand Current (PE) (1s)	$I_{cw}$	kA	6	9	9	18	18	21	21	10,6	10,6	15	21	21	
Rated Peak Withstand Current (PE)	$I_{pk}$	kA	10,2	15,3	15,3	36	36	44,1	44,1	21,6	21,6	30	44,1	44,1	
<b>MEAN PHASE CONDUCTOR CHARACTERISTICS AT RATED CURRENT <math>I_n</math></b>															
Resistance at a conductor temperature of 20 °C	$R_{20}$	mW/m	0,314	0,238	0,200	0,115	0,094	0,075	0,049	0,170	0,135	0,109	0,066	0,044	
Resistance at an ambient air temperature of 35 °C	R	mW/m	0,379	0,309	0,271	0,151	0,127	0,104	0,066	0,213	0,172	0,145	0,090	0,061	
Reactance (Independent from Temperature)	X	mW/m	0,169	0,158	0,147	0,111	0,094	0,083	0,064	0,171	0,159	0,147	0,112	0,085	
Positive and negative sequence impedances at an ambient air temperature of 35 °C	Z	mW/m	0,415	0,347	0,308	0,188	0,158	0,133	0,092	0,273	0,234	0,206	0,143	0,104	
Positive and negative sequence impedances at a conductor temperature of 20 °C	$Z_{20}$	mW/m	0,356	0,286	0,248	0,160	0,133	0,112	0,081	0,241	0,208	0,183	0,130	0,096	
Rated Power Loss at 35 °C		mW/m	29,0	56,2	78,1	69,0	91,4	110,0	123,8	38,3	49,5	67,9	94,0	112,5	
DC Resistance at a conductor temperature of 20 °C for Phases	$R_{ort_{ph}}$	mW/m	0,292	0,221	0,189	0,108	0,087	0,072	0,043	0,151	0,119	0,098	0,058	0,039	
DC Resistance at a conductor temperature of 20 °C for Neutral	$R_N$	mW/m	0,292	0,219	0,188	0,111	0,089	0,072	0,044	0,152	0,119	0,098	0,059	0,039	
DC Resistance at a conductor temperature of 20 °C for PE	$R_{PE}$	mW/m	0,320	0,303	0,295	0,273	0,318	0,296	0,232	0,299	0,305	0,302	0,255	0,240	
<b>SECTIONS</b>															
L1,L2,L3,N		mm <sup>2</sup>	120	150	180	300	375	450	660	120	150	180	300	450	
PE (4 ½ Conductors)		mm <sup>2</sup>	60	75	90	150	187,5	225	330	60	75	90	150	225	
PE (5 Conductors)		mm <sup>2</sup>	120	150	180	300	375	450	660	120	150	180	300	450	
Housing Section (Sheet Metal)		mm <sup>2</sup>	583	593	603	643	668	693	730	583	593	603	643	693	
Conductor Dimensions		mmxmm	6x20	6x25	6x30	6x50	6x62,5	6x75	6x110	6x20	6x25	6x30	6x50	6x75	
Busbar Weight (4 Conductors)(1)		kg/m	7	7,5	8	10	11	12	15,1	10	11	12,5	16	18	
Busbar Weight (5 Conductors)(1)		kg/m	7,3	8	8,7	11	12	13	17	11	12,5	14	19	21	
<b>MEAN FAULT-LOOP CHARACTERISTICS</b>															
Zero-sequence Impedance															
Zero-sequence impedance at a conductor temperature of 20 °C	$Z^{(0)}_{b20phN}$	mW/m	1,669	1,374	1,223	0,815	0,670	0,581	0,411	1,177	1,013	0,897	0,625	0,464	
Zero-sequence impedance at a conductor temperature of 20 °C	$Z^{(0)}_{b20phPE}$	mW/m	2,209	1,834	1,696	1,408	1,443	1,256	1,003	1,818	1,608	1,453	1,181	1,052	
Zero-sequence impedance at an ambient temperature of 35 °C	Z(0) bphN	mW/m	1,925	1,651	1,497	0,956	0,796	0,699	0,473	1,319	1,137	1,014	0,703	0,516	
Zero-sequence impedance at an ambient temperature of 35 °C	Z(0) bphPE	mW/m	2,590	2,277	2,167	1,753	1,874	1,669	1,294	2,167	1,952	1,814	1,530	1,386	
<b>RESISTANCES AND REACTANCES</b>															
Resistance at a conductor temperature of 20 °C	Rb20phph	mW/m	0,627	0,475	0,408	0,239	0,191	0,159	0,098	0,335	0,265	0,222	0,134	0,091	
Resistance at a conductor temperature of 20 °C	Rb20phN	mW/m	0,648	0,496	0,428	0,258	0,204	0,169	0,105	0,359	0,287	0,242	0,148	0,101	
Resistance at a conductor temperature of 20 °C	Rb20phPE	mW/m	0,837	0,777	0,745	0,606	0,570	0,506	0,401	0,709	0,656	0,612	0,495	0,417	
Resistance at an ambient air temperature of 35 °C	Rbphph	mW/m	0,763	0,623	0,552	0,315	0,259	0,221	0,134	0,419	0,340	0,294	0,185	0,127	
Resistance at an ambient air temperature of 35 °C	RbphN	mW/m	0,788	0,651	0,580	0,340	0,277	0,236	0,143	0,449	0,369	0,321	0,204	0,141	
Resistance at an ambient air temperature of 35 °C	RbphPE	mW/m	1,018	1,019	1,010	0,799	0,774	0,706	0,544	0,886	0,843	0,812	0,684	0,580	
Reactance (Independent from temperature)	Xbphph	mW/m	0,331	0,308	0,282	0,212	0,178	0,158	0,123	0,328	0,302	0,277	0,210	0,159	
Reactance (Independent from temperature)	XbphN	mW/m	0,441	0,418	0,389	0,299	0,249	0,224	0,179	0,441	0,412	0,382	0,296	0,228	
Reactance (Independent from temperature)	XbphPE	mW/m	0,438	0,460	0,442	0,384	0,327	0,304	0,268	0,453	0,445	0,421	0,359	0,295	

(1) Joint weight is included rated 1/3 of the weight of the joint in the indicated weights per meter.

# E-LINE KO-II

## Standard Components

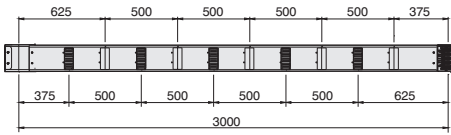
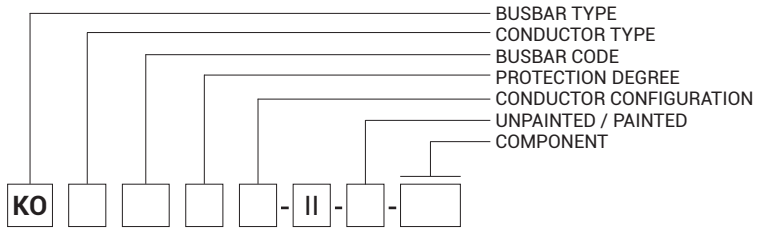

Sample Order:  
250 A, Aluminium, Plug-in,  
IP 55, 4 Conductors  
**KOA 0254-II-STD**

Electrical Power up to 400A can be supplied from the busbar by Tap-off boxes.

E-Line KO-II Busbar is manufactured in 3m lengths as standard, special lengths can be manufactured on request.

- Your special plug-in window requests, please note that the tap off boxes that you will attach to the plug-in points do not overlap each other.
- Your plastic tap off box options; The first plug-in window minimum size should be 275mm, The final plug-in window minimum size should be 330mm.

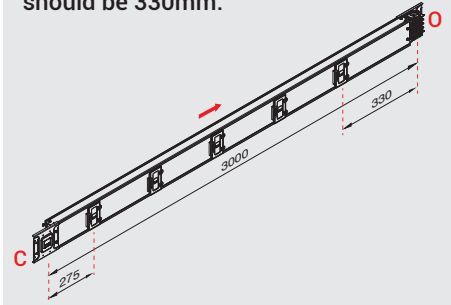

Sample Order:  
400 A, Copper, Plug-in,  
IP 55, 850 mm, 5 Conductors  
**KOC 0455-II-85**

Minimum special length that can be manufactured for the plug-in busbar is 1000 mm.

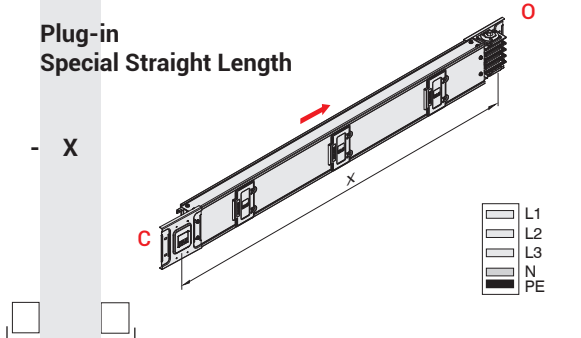
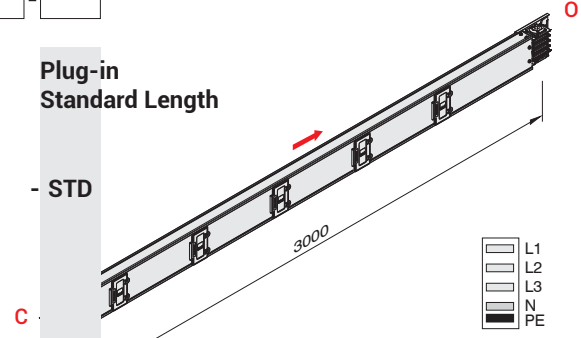

X Special Straight Length (mm)

Sample Order:  
315 A, Aluminium, Feeder,  
IP 55, 5 Conductors  
**KOA 0355-II-FTD**

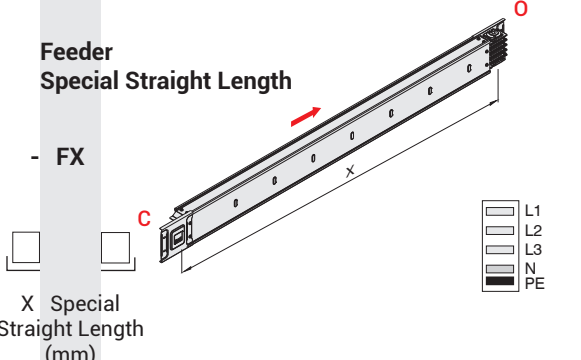
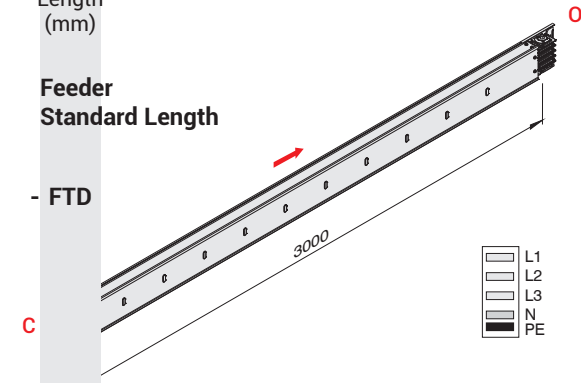

X Special Straight Length (mm)

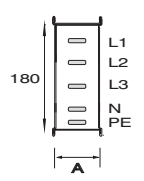

Current	Aluminium	Copper
(A)	(A) mm	(A) mm
160	70	-
250	75	70
315	80	75
400	100	80
500	112	-
600	125	100
800	160	125

Busbar cross-section dimension. Please call us for non-standard components.

# E-LINE KO-II

## Elbows

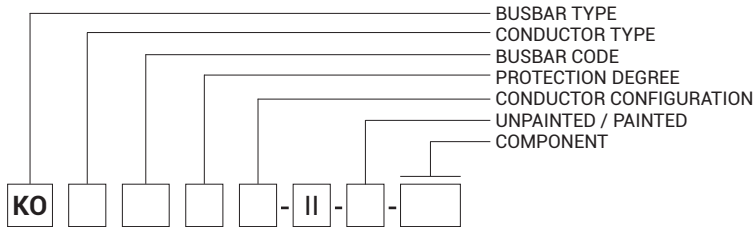

Current		A	B
ALUMINIUM	160	180	145
	250	185	147
	315	190	150
	400	210	160
	500	222	166
	600	235	172
COPPER	250	180	145
	315	185	147
	400	190	150
	600	210	160
	800	235	172

Sample Order:  
 250 A, Aluminium, IP 55, 4 Conductors  
**KOA 0254-II-R**

### Right Elbow

R

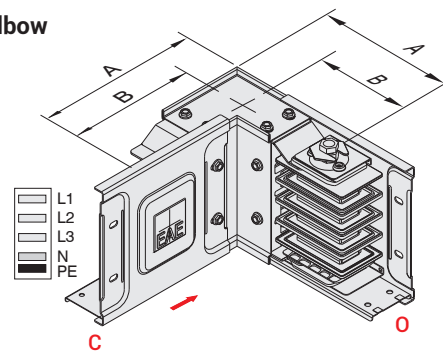

Sample Order:  
 600 A, Copper, IP 55, 5 Conductors  
**KOA 0655-II-L**

### Left Elbow

L

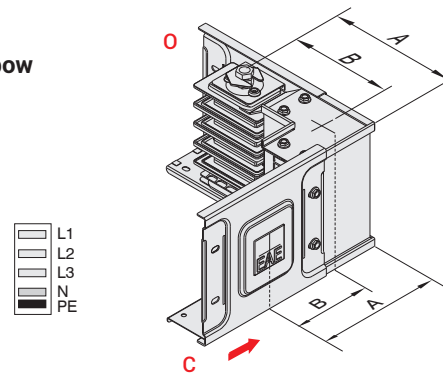

Sample Order:  
 400 A, Aluminium, IP 55, 4 Conductors  
**KOA 0454-II-D**

### Downwards Elbow

D

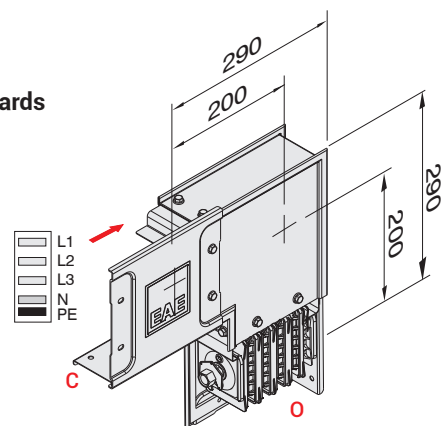

Sample Order:  
 600 A, Copper, IP 55, 5 Conductors  
**KOA 0655-II-U**

### Upwards Elbow

U

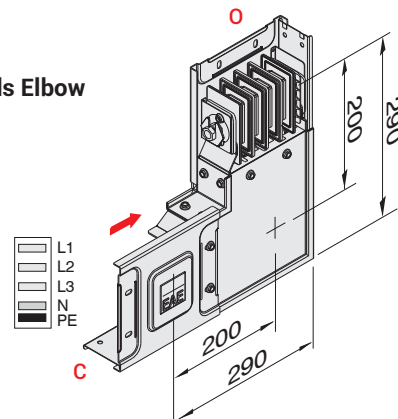



# E-LINE KO-II

## Elbows

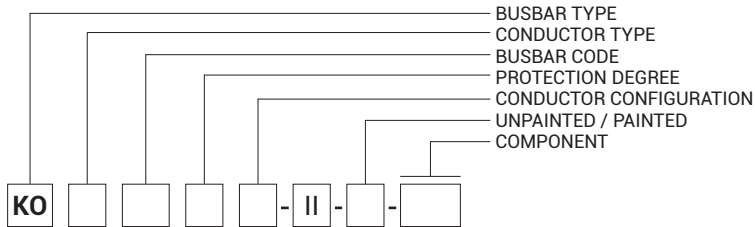

H= min. 200 mm.  
 Sample Order:  
 250 A, Aluminium, IP 55,  
 4 Conductors  
**KOA 0254-II-KRU**

### Right Upwards Combined Offset

- KRU

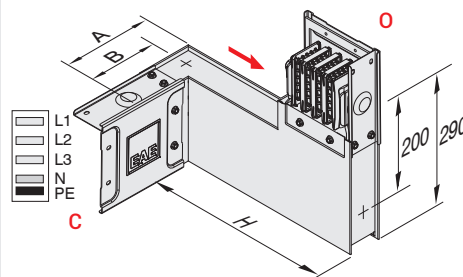

### Left Upwards Combined Offset

- KLU

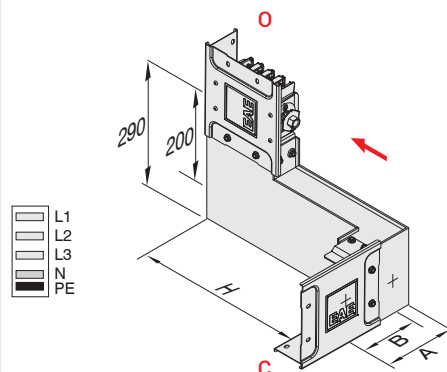

### Right Downwards Combined Offset

- KRD

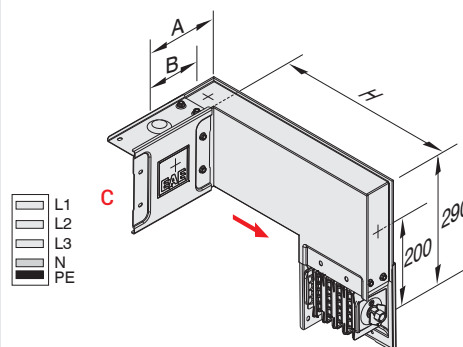

### Left Downwards Combined Offset

- KLD

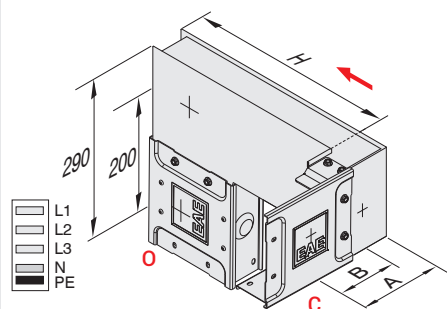

	Current	A	B
ALUMINIUM	160	180	145
	250	185	147
	315	190	150
	400	210	160
	500	222	166
	600	235	172
COPPER	800	270	190
	250	180	145
	315	185	147
	400	190	150
	600	210	160
	800	235	172

H= min. 200 mm.  
 Sample Order:  
 400 A, Copper, IP 55,  
 5 Conductors  
**KOC 0455 -II- KLU**

H= min. 200 mm.  
 Sample Order:  
 315 A, Aluminium, IP 55,  
 5 Conductors  
**KOA 0355 -II- KRD**

H= min. 200 mm.  
 Sample Order:  
 160 A, Aluminium, IP 55,  
 4 Conductors  
**KOA 0154-II-KLD**

# E-LINE KO-II

## Elbows

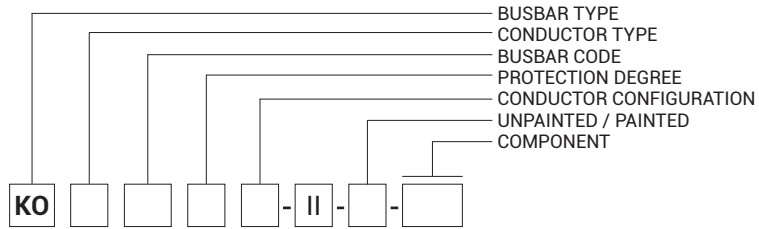

	Current	A	B
ALUMINIUM	160	180	145
	250	185	147
	315	190	150
	400	210	160
	500	222	166
	600	235	172
COPPER	800	270	190
	250	180	145
	315	185	147
	400	190	150
	600	210	160
	800	235	172

H= min. 200 mm.  
 Sample Order:  
 250 A, Aluminium, IP 55,  
 4 Conductors  
**KOA 0254 -II- KUR**

### Upwards Right Combined Offset

- KUR

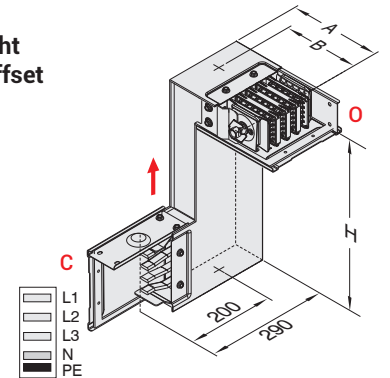

H= min. 200 mm.  
 Sample Order:  
 400 A, Copper, IP 55,  
 5 Conductors  
**KOC 0455 -II- KUL**

### Upwards Left Combined Offset

- KUL

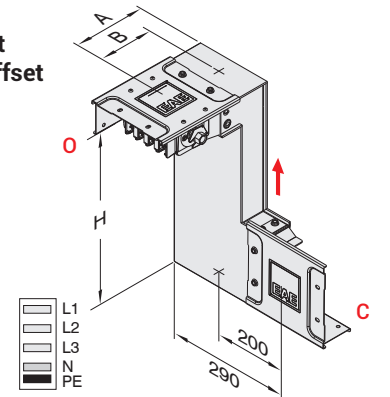

H= min. 200 mm.  
 Sample Order:  
 315 A, Aluminium, IP 55,  
 5 Conductors  
**KOA 0355 -II- KDR**

### Downwards Right Combined Offset

- KDR

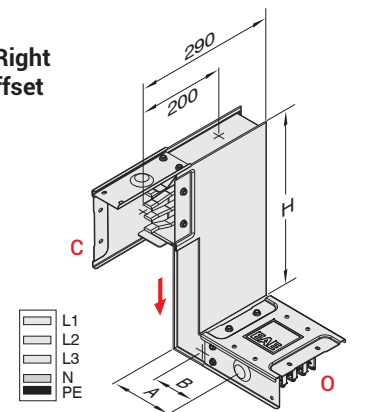

H= min. 200 mm.  
 Sample Order:  
 160 A, Aluminium, IP 55,  
 4 Conductors  
**KOA 0154-II-KDL**

### Downwards Left Combined Offset

- KDL

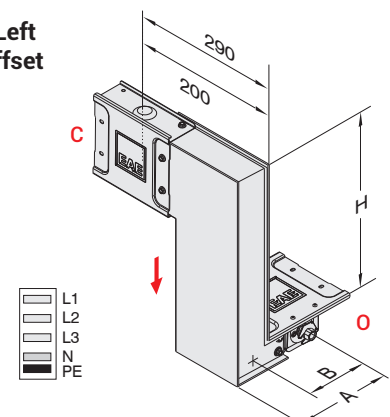

# E-LINE KO-II

## Standard Components

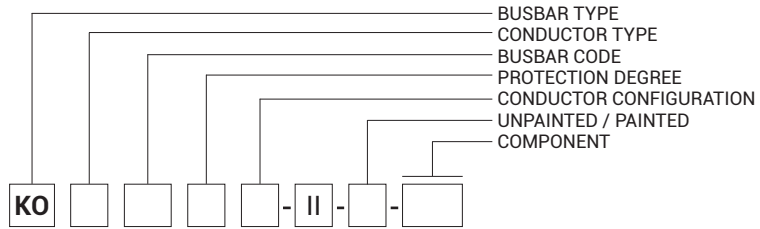

### Reduction

Is used to change the busbar cross section.

### NOTE:

The selection of the reduction unit and the lower side protection is the responsibility of the customer.

Sample Order:  
400-250 A, Aluminium,  
IP 55,5 Conductors  
**KOA 0455-II-RD2**

### Reduction

- RD

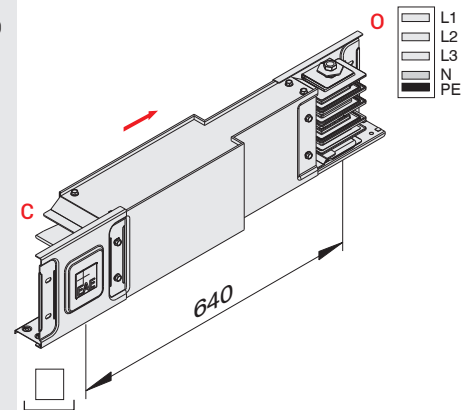

### Reducers Table

**KOA - Al Conductor**

Rated Current	Reduced Busbar Current					
	160	250	315	400	500	600
250	✓	-	-	-	-	-
315	✓	✓	-	-	-	-
400	-	✓	✓	-	-	-
500	-	-	✓	✓	-	-
600	-	-	-	✓	✓	-
800	-	-	-	-	✓	✓

**KOC - Cu Conductor**

Rated Current	Reduced Busbar Current			
	250	315	400	600
315	✓	-	-	-
400	✓	✓	-	-
600	-	✓	✓	-
800	-	-	✓	✓

Sample Order:  
250 A, Aluminium, IP 55,  
4 Conductors  
**KOC 0254 -II- T**

### "T" Component

- T

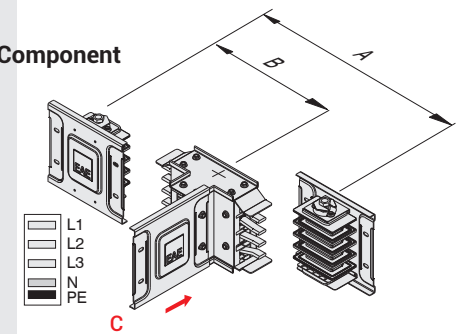

	Current	A	B
ALUMINIUM	160	290	145
	250	295	147
	315	300	150
	400	320	160
	500	332	166
	600	345	172
COPPER	250	290	145
	315	295	147
	400	300	150
	600	320	160
	800	345	172

Sample Order:  
600 A, Aluminium, IP 55,  
4 Conductors  
**KOA 0654-II-DD**

### Cross

- DD

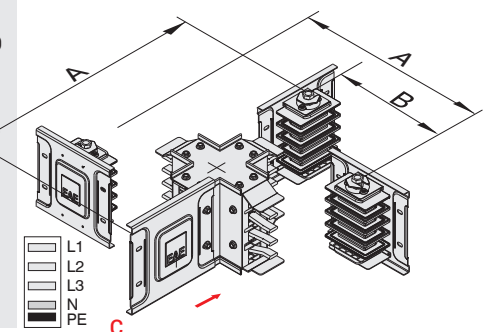

Please call us for non-standard components.

# E-LINE KO-II

## Standard Components

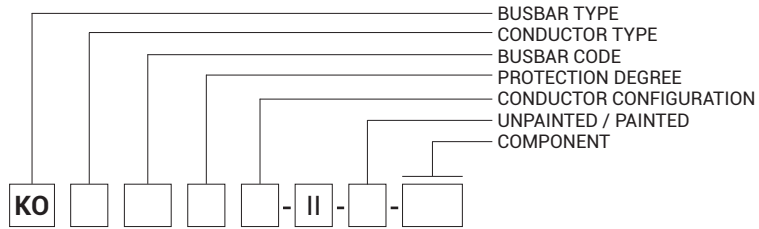

### End Closer

Is used to close the end of busbar run.

Sample Order:  
250 A, Copper, IP 55, 5 Conductors  
**KOC 0255 -II- S**

### End Closer

- S

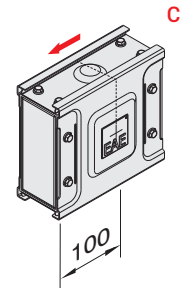

### Horizontal Expansion

For long horizontal runs and for crossing the building expansions.  
(See page no.27 for application)

Sample Order:  
250 A, Aluminium, IP 55, 4 Conductors  
**KOA 0254 -II- YDT**

### Horizontal Expansion

- YDT

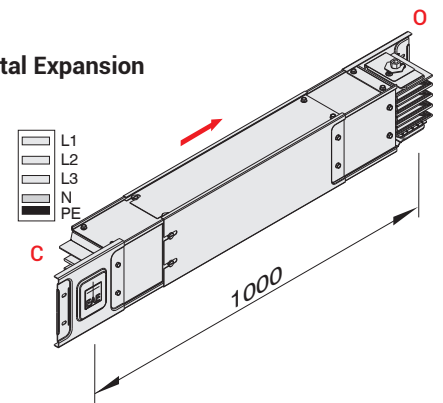

### Vertical Expansion

For vertical applications in multi- storey buildings.  
(See page no.27 for application)

Sample Order:  
250 A, Copper, IP 55, 5 Conductors  
**KOC 0255 -II- DDT**

### Vertical Expansion

- DDT

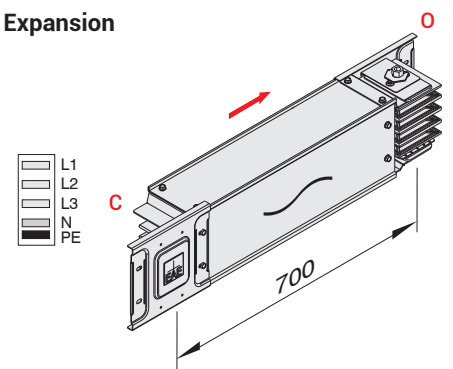

### Flexibles

Are used for panel-busbar connections.

Sample Order:  
600 A, Aluminium, 4 Conductors 550 mm.  
**KOA 0454 -II- F55**

### Flexibles

- F

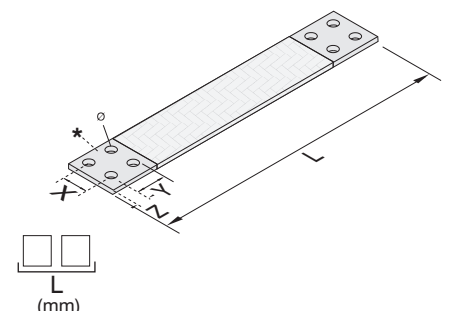

Please call us for non-standard components.

\* Please indicate X, Y, Z and  $\phi$  measurement on order.

# E-LINE KO-II

## Feeder Boxes

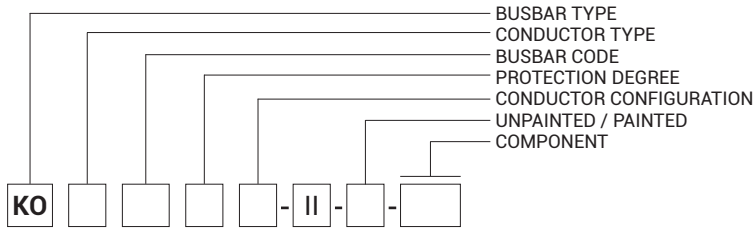

Sample Order:  
250 A, Copper IP 55,  
5 Conductors  
**KOC 0255-II-B1**

### 4 conductors

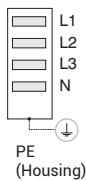
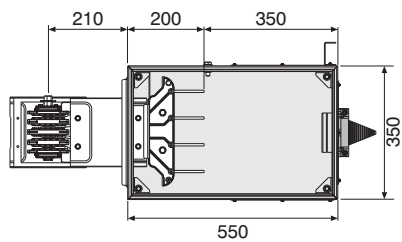

### 4,5 / 5 PE conductors

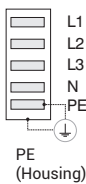
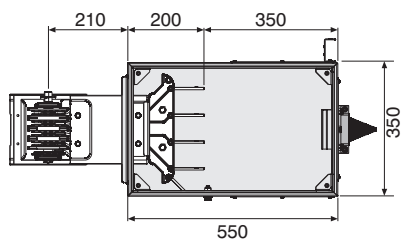

### 4,5 / 5 CPE (Clean Earth) conductors

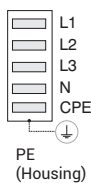
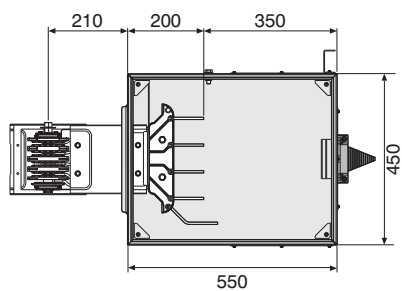

	Current	A	B	C
ALUMINIUM	160	70	180	260
	250	75	180	260
	315	80	180	260
	400	100	180	260
	500	112	240	315
	600	125	240	315
	800	160	300	375
COPPER	250	70	180	260
	315	75	180	260
	400	80	180	260
	600	100	180	260
	800	125	240	315

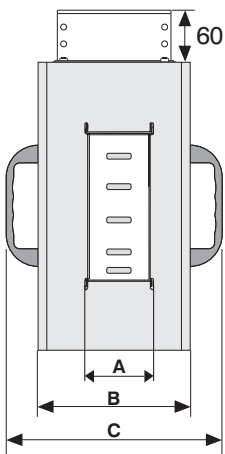

### Feeder Box 1

- B1

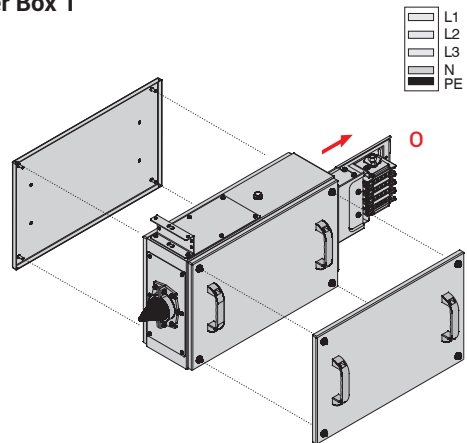

### Feeder Box 2

- B2

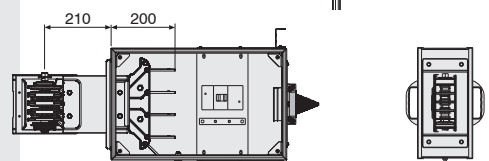
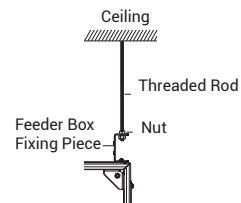
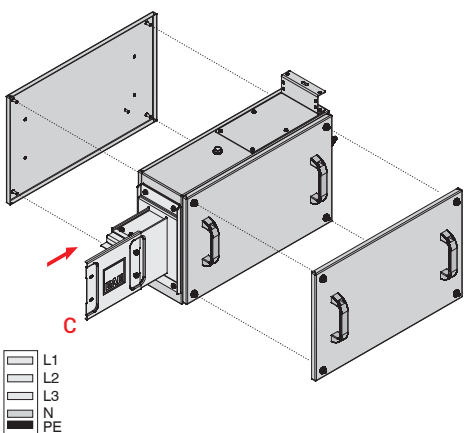

Feeder Box sample equipped with MCCB

Please call us for special applications or for applications with MCB's

# E-LINE KO-II

## Feeder Boxes

### Central Feeder Box BO

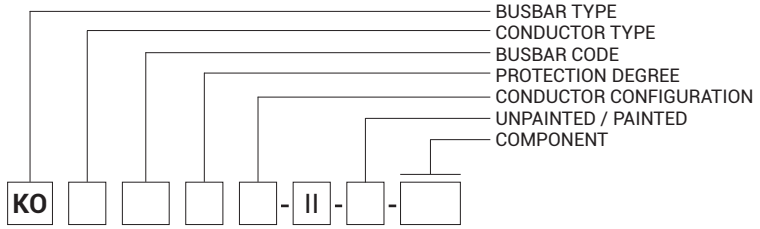

**Central Feeder Box BO 1**  
 Sample Order:  
 600 A, Aluminium, IP 55, 4 Conductors - B01  
**KOA 0654 -II- B01**

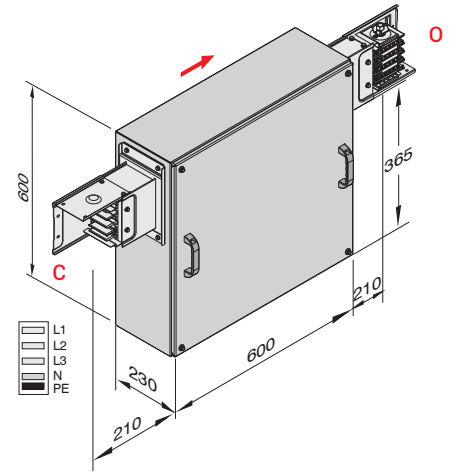

**Central Feeder Box BO 2**  
 Sample Order:  
 600 A, Aluminium, IP 55, 4 Conductors - B02  
**KOA 0654 -II- B02**

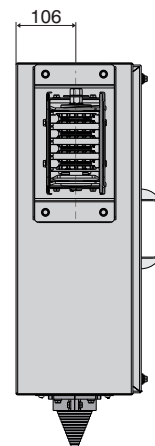
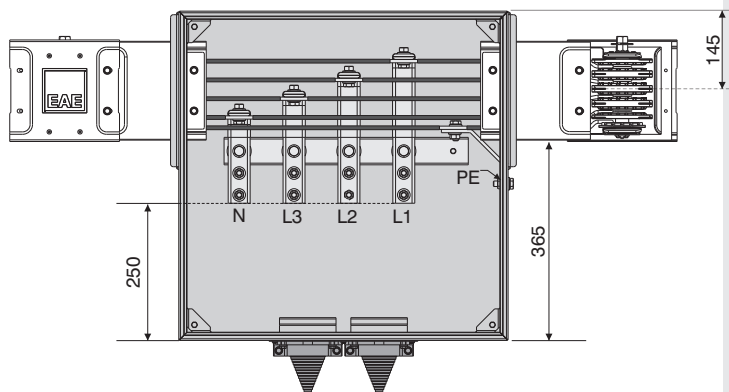
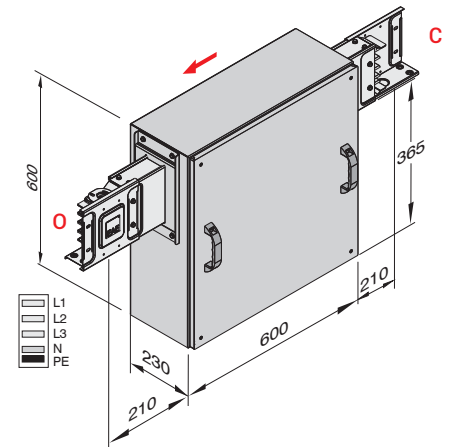

Please call us for special applications or for applications with MCCB's

# E-LINE KO-II

## Feeder Boxes

Central Feeder Box  
KOA 800- KOC 800A

- BUSBAR TYPE
- CONDUCTOR TYPE
- BUSBAR CODE
- PROTECTION DEGREE
- CONDUCTOR CONFIGURATION
- UNPAINTED / PAINTED
- COMPONENT

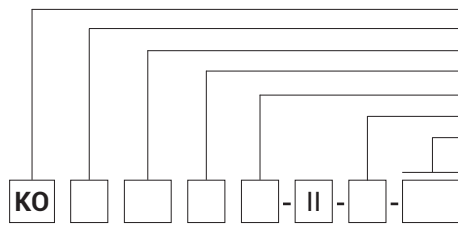

### Central Feeder Box BO 1

Sample Order:  
800 A, Copper IP 55, 4 Conductors  
**KOC 0854 -II- BO1**

- BO1

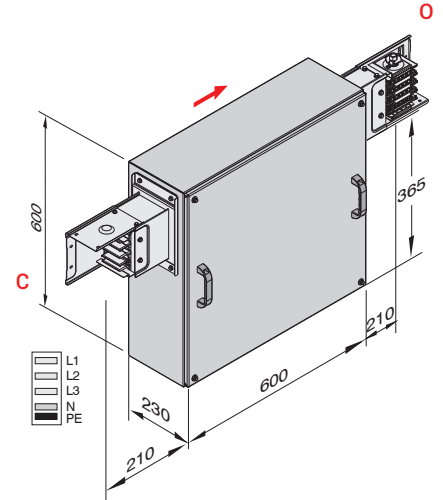

### Central Feeder Box BO 2

Sample Order:  
800 A, Copper IP 55, 4 Conductors  
**KOC 0854 -II- BO2**

- BO2

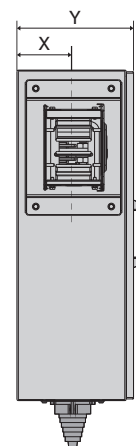
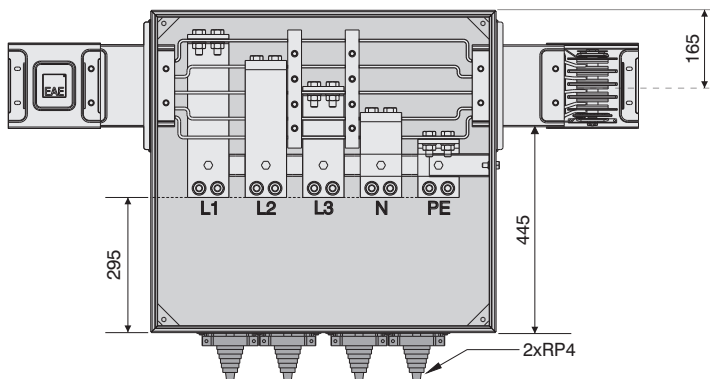
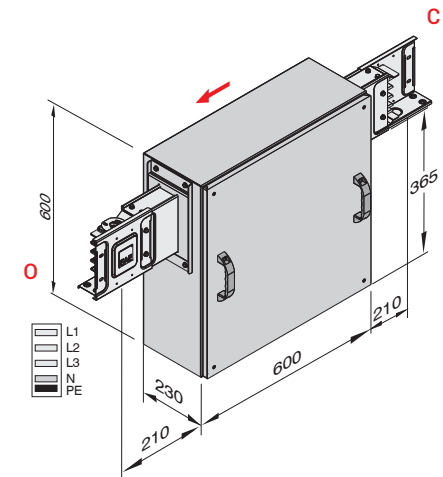

Current	X	Y
KOA 800	145	292
KOC 800	120	247

Please call us for special applications or for applications with MCCB's

# E-LINE KO-II

## Selection of Feeder Boxes

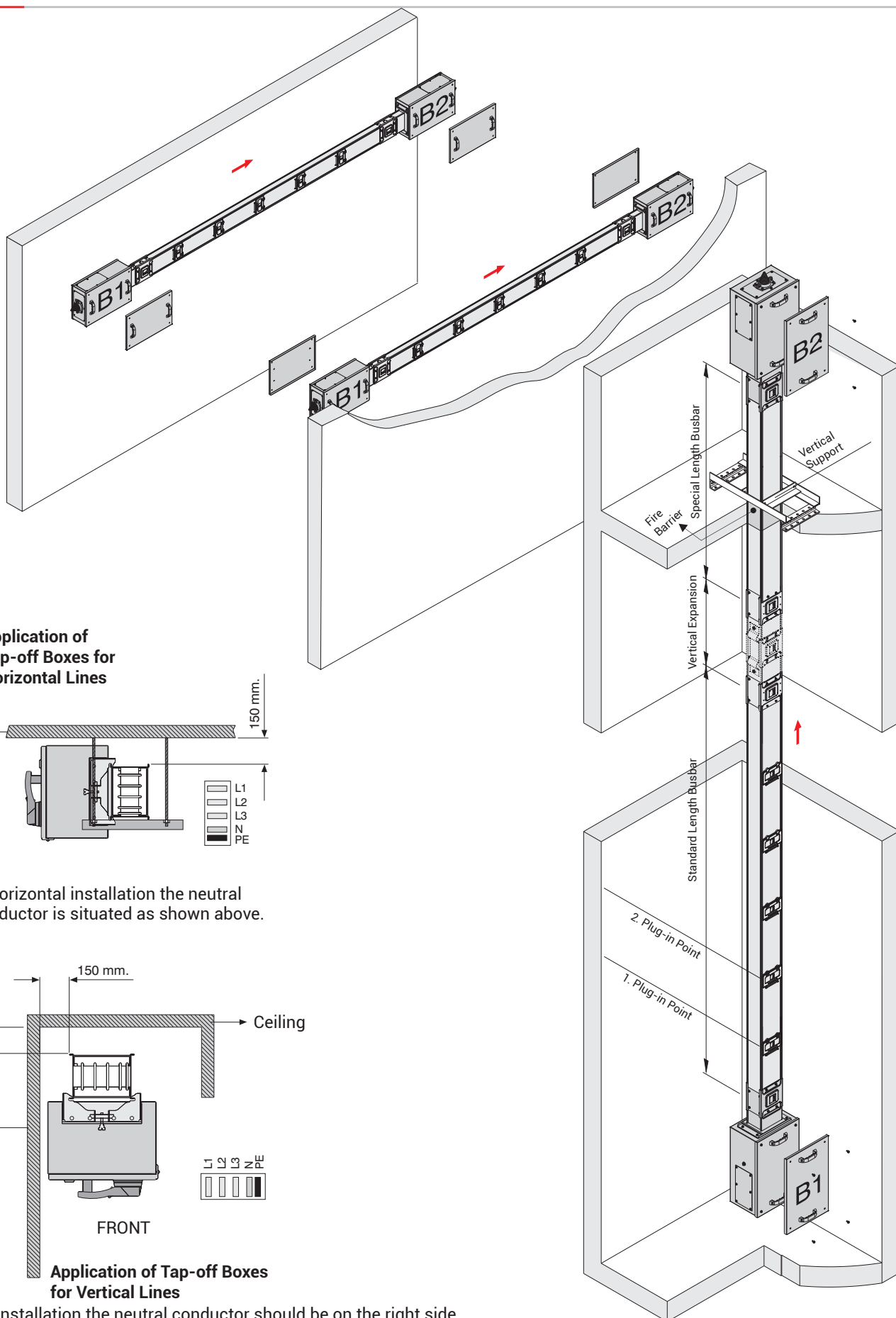

### Application of Tap-off Boxes for Horizontal Lines

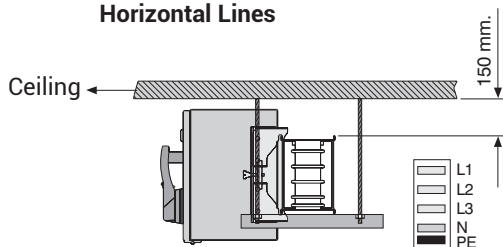

In horizontal installation the neutral conductor is situated as shown above.

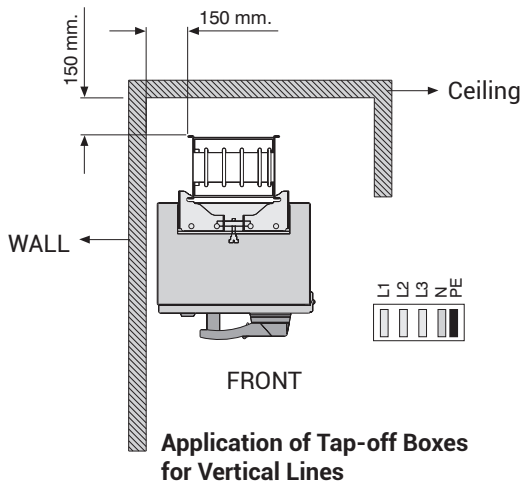

### Application of Tap-off Boxes for Vertical Lines

In vertical installation the neutral conductor should be on the right side. It is important for tap-off box connections.

# E-LINE KO-II

## Panel Connections

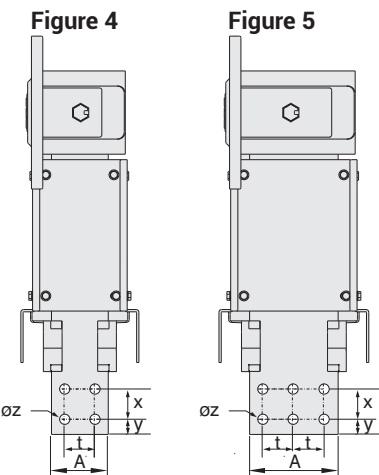
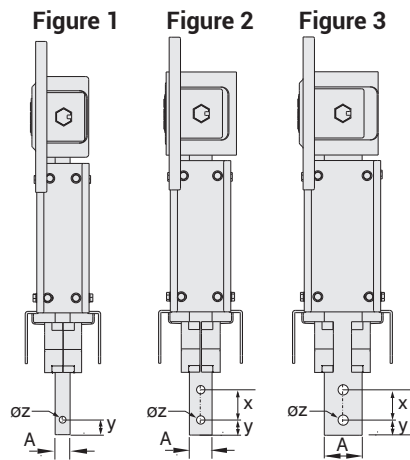
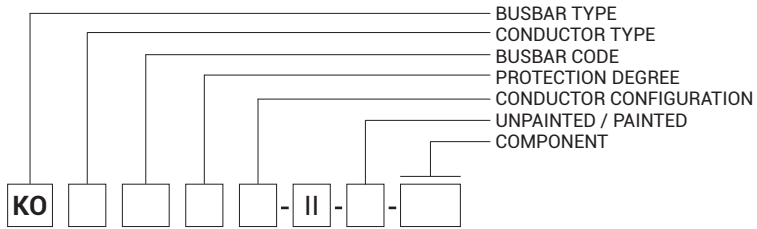

Sample Order:  
600 A, Aluminium, IP 55, 5 Conductors  
**KOA 0655-II-P10**

Sample Order:  
600 A, Aluminium, IP 55, 5 Conductors  
**KOA 0655-II-P11**

	Current	A	x	y	z	t	Figure
ALUMINIUM	160	20	40	20	9	-	1
	250	25	40	20	11	-	2
	315	30	40	20	11	-	2
	400	50	40	20	13	-	3
	500	62,5	40	20	13	-	3
	600	75	40	20	13	40	4
	800	110	40	20	13	40	5
COPPER	250	20	40	20	9	-	1
	315	25	40	20	11	-	2
	400	30	40	20	11	-	2
	600	50	40	20	13	-	3
	800	75	40	20	13	40	4

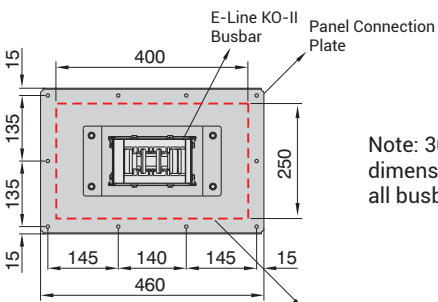

Note: 300x460mm flange plate dimensions are standard for all busbar types.

Opening on the panel board

### Busbar Feeder

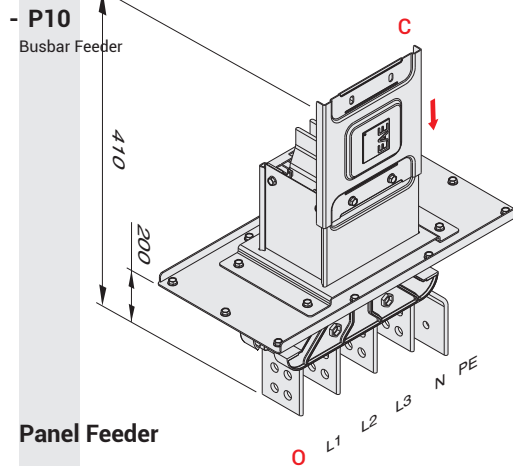

### Panel Feeder

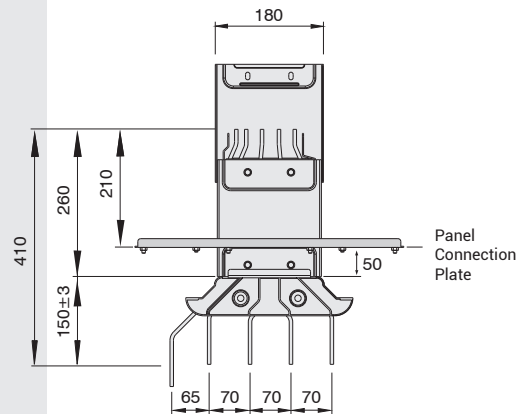
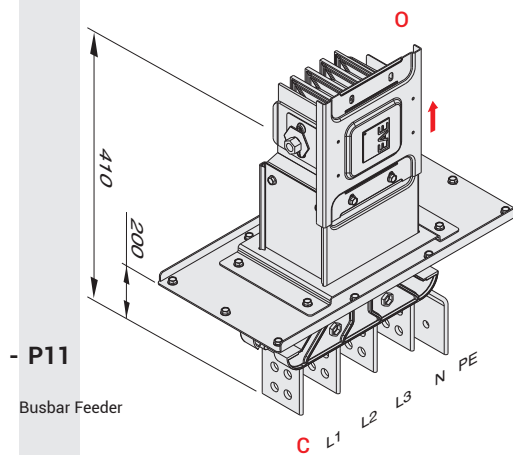

Please call us for non-standard components.

# E-LINE KO-II

## Tap-Off Boxes with Fused Switches (SYK)

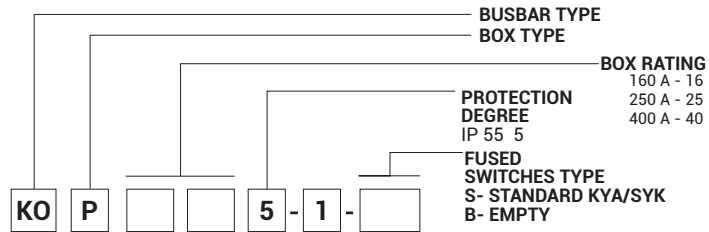

### Cable Gland Plates

Mat.	Cable Gland Type	Order Code	Inner Diameter (mm)
Mat.	Cable Gland Type	RP0	---
Sheet Metal	---	RP1	25
Sheet Metal	M32	RP2	32
Sheet Metal	M40	RP3	63
Sheet Metal	Special	RP4	63
AL	2xSpecial	RP5	18
AL	4xM25	RP6	25
AL	4xM32	RP7	32
AL	4xM40	RP8	32
AL	8xM32	RP8	25

KOP 1651-S

KOP 2551-S

KOP 4051-S

### Fused Switches (SYK)

Tap-off boxes are equipped with EAE syk fused switches that;

- Can operate under load,
- Are equipped with NH fuse holders,
- Have Interlock mechanism
- Padlock applicable

CURRENT (A)	A	B	C	D	Cable Gland	Fuse Size	Fused Switches	5W Order No
KOP 160	370	300	195	135	RPK1	NH 00	KYA	3030205
KOP 250	480	380	245	150	RP2	NH 1	KYA	3030207
KOP 400	625	380	255	215	RP3	NH 3	SYK	3030314

Tap-off boxes can be equipped with other brand of fused switches on request. Tap-off boxes are painted in red as standard. Continuous current of tap-off boxes with fused switch should not exceed 80% of tap-off box current rating.

■ Please call us for non-standard components.

■ As of January 1, 2025, it is produced in RAL 7035. For different color options, please contact our customer representatives.

■ When requesting special size tap off boxes, make sure that the distance between the two plug point does not prevent the installation of the tap off boxes.

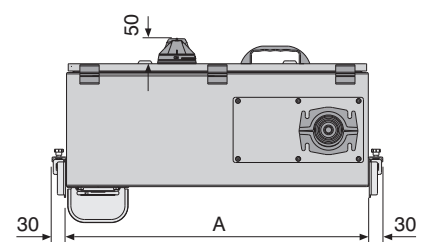
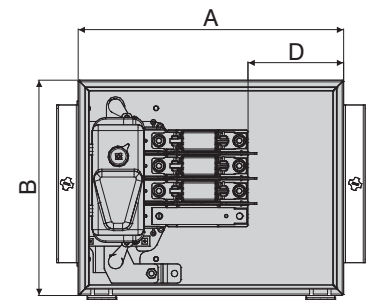
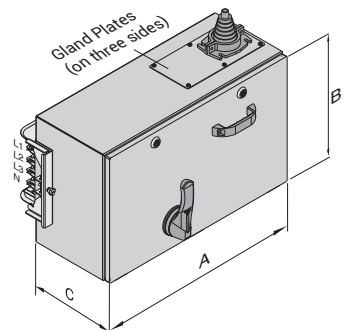
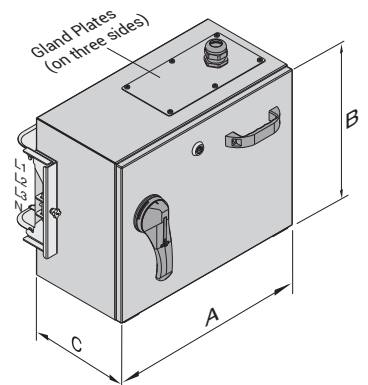
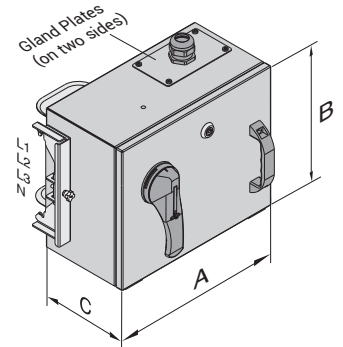

# E-LINE KO-II

## Tap-Off Boxes for MCCB's

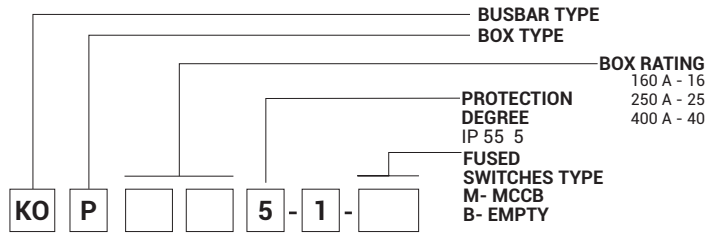

### Cable Gland Plates

Mat.	Cable Gland Type	Order Code	Inner Diameter (mm)
Sheet Metal	---	RP0	---
Sheet Metal	M32	RP1	25
Sheet Metal	M40	RP2	32
Sheet Metal	M40	RP3	63
Sheet Metal	Special	RP4	63
AL	2xSpecial	RP5	18
AL	4xM25	RP6	25
AL	4xM32	RP7	32
AL	4xM40	RP7	32
AL	8xM32	RP8	25

### Special Cable Gland Plates

Mat.	Cable Gland Type	Order Code	Inner Diameter (mm)
Sheet Metal	---	RPK0	---
Sheet Metal	M25	RPK1	25
Sheet Metal	M32	RPK2	32
Sheet Metal	M40	RPK3	63
Sheet Metal	1xSpecial	RPK4	63

CURRENT (A)	A	B	C	Cable Gland	5W Order No
KOP 160	420	300	220	RPK2	3030192
KOP 250	500	300	220	RPK3	3030193
KOP 400	675	300	220	RP3	3030194

\* EAE tap-off boxes can be designed for all brands of MCCB's.

KOP 1651-M  
KOP 1651-B

KOP 2551-M  
KOP 2551-B

KOP 4051-M  
KOP 4051-B

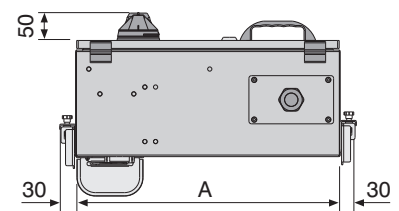
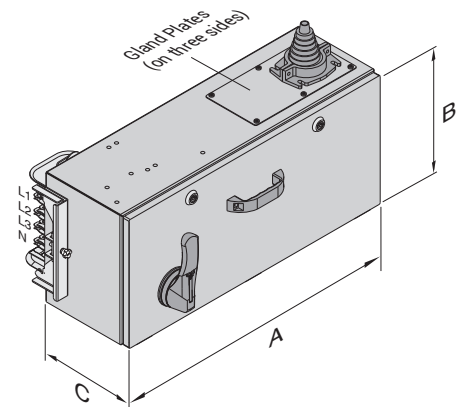
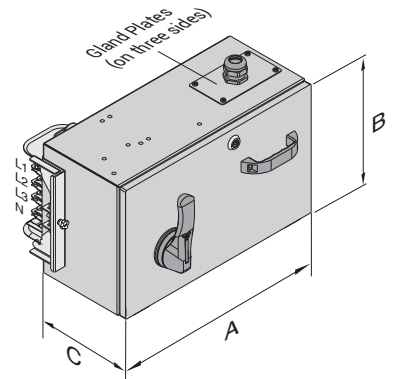
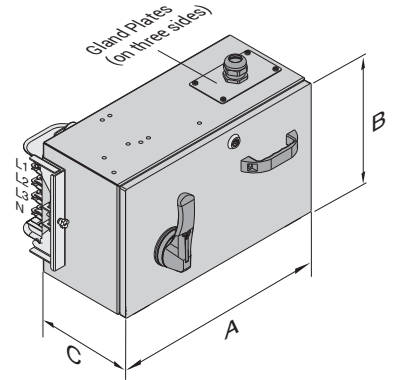

■ Please call us for non-standard components.

■ As of January 1, 2025, it is produced in RAL 7035. For different color options, please contact our customer representatives.

■ When requesting special size tap off boxes, make sure that the distance between the two plug point does not prevent the installation of the tap off boxes.

# E-LINE KO-II

## KOP-Data Tap-Off Boxes (125A)

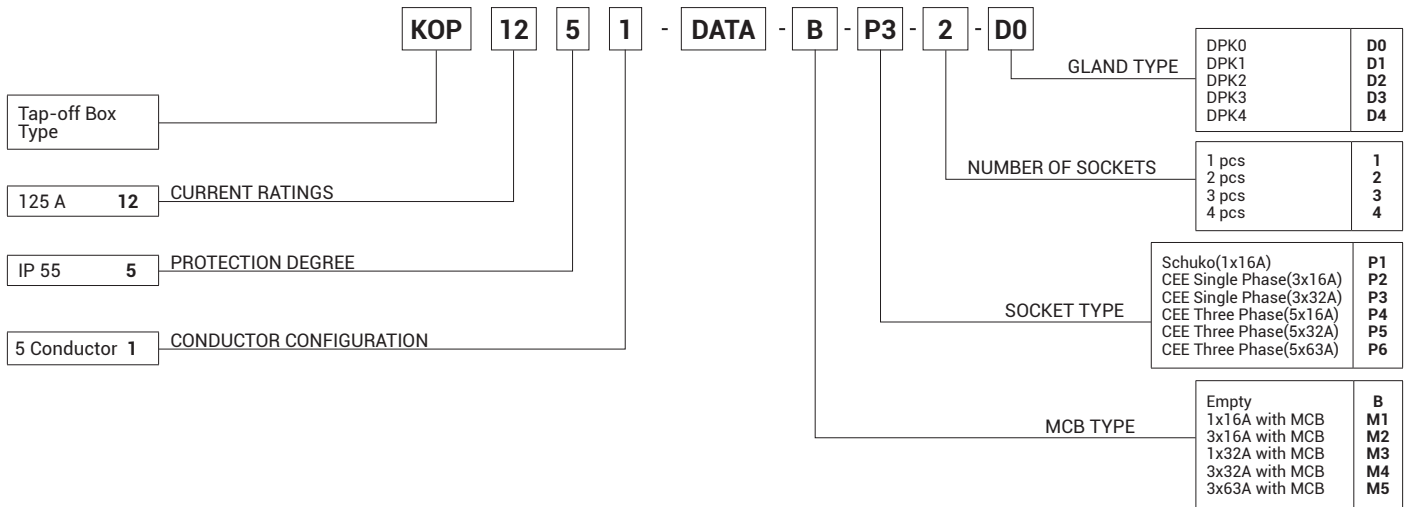

### Cable Gland Plates

Mat.	Cable Gland Type	Order Code	Inner Diameter (mm)
Al	---	DPK0	---
Al	M16	DPK1	10
Al	10xM16	DPK2	10
Al	M25	DPK3	18
Al	4xM25	DPK4	18

#### Features;

- Up to 125A MCB
- RAL 7038 Painted Aluminium Housing
- Standard tap-off is empty, gland plates are DPK0.
- with DIN rail inside(available for 4pcs 3P MCB)
- May be equipped with CEE or Schuko Sockets with different configurations.( Optional)
- All tap off boxes with equipment fitted are manufactured with C Type ABB MCB.

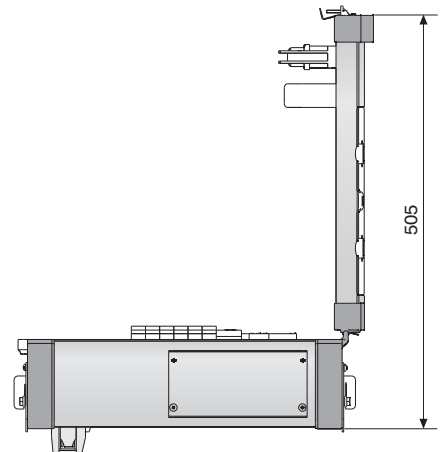
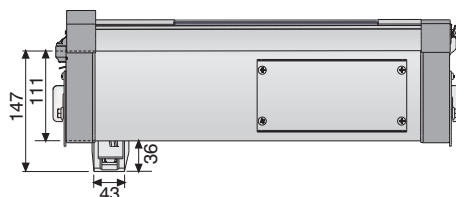
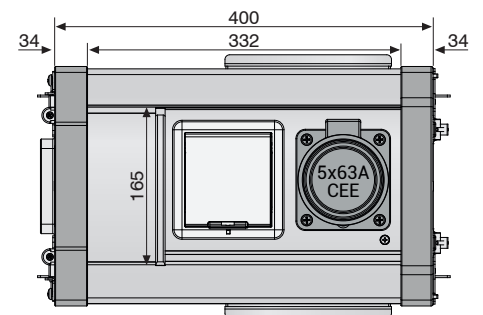
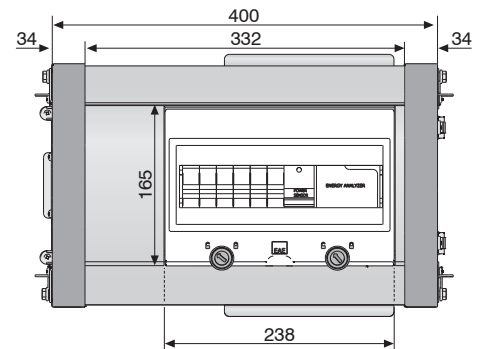

■ Please call us for non-standard components.

■ As of January 1, 2025, it is produced in RAL 7035. For different color options, please contact our customer representatives.

■ When requesting special size tap off boxes, make sure that the distance between the two plug point does not prevent the installation of the tap off boxes.

# E-LINE KO-II

## Tap-Off Boxes

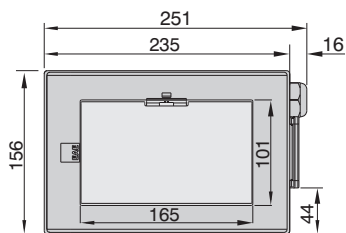
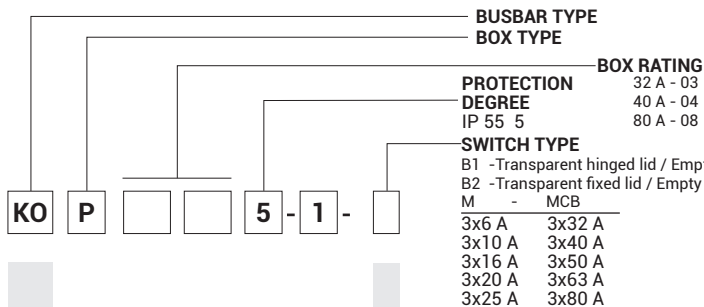

**KOP 0351-P1**  
**KOP 0351-P2**

Sample Order:  
 32 A, IP 55, 5 wire,  
 hinged lid, suitable for 8pcs  
 MCB, empty tap off box

P1

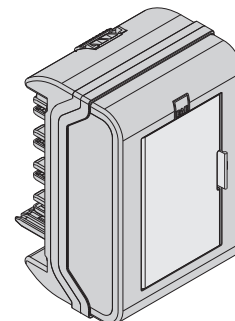

suitable for 8pcs MCB

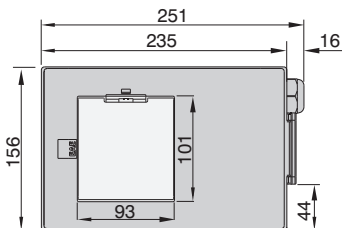

**KOP 0351 - P1**

Sample Order:  
 32 A, IP 55, 5 wire,  
 hinged lid, suitable for 4pcs  
 MCB, empty tap off box

P2

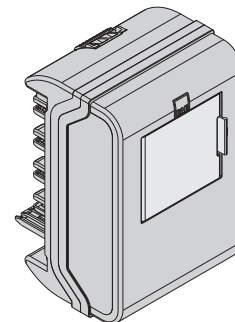

suitable for 4pcs MCB

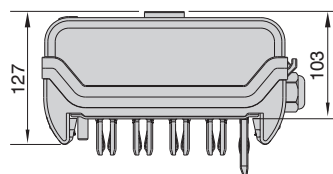

**KOP 0351 - P2**

**KOP 0451-B1**  
**KOP 0851-B1**

Sample Order:  
 40 A, IP 55, 5 wire, transparent  
 hinged lid, suitable for MCB,  
 empty tap off box

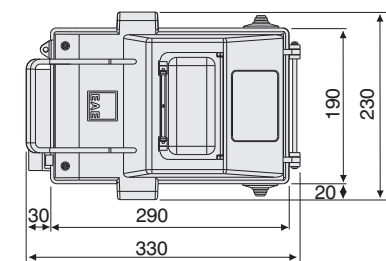

P2

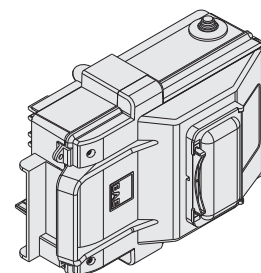

**KOP 0451 - B1**

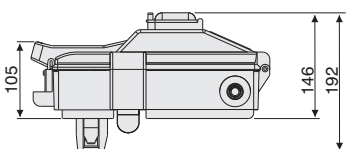

**KOP 0451-B2**  
**KOP 0851-B2**

Sample Order:  
 40 A, IP 55, 5 wire, transparent  
 fixed lid, suitable for MCB,  
 empty tap off box

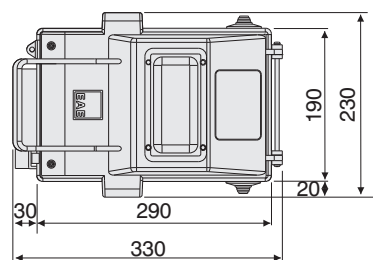

**KOP 0451 - B2**

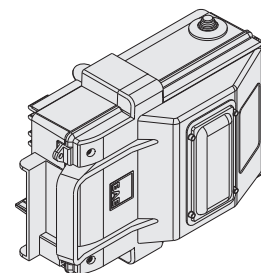
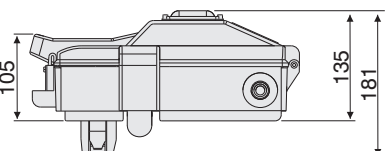

Please call us for non-standard components.

# E-LINE KO-II

## Fixing Elements



### Supports

Description	Code
KO-II Vertical Riser Fixing Unit	3048476

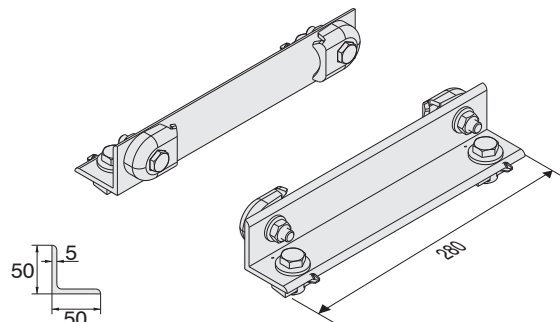

Description	Code
KO-II Vertical Riser Fixing Unit (Fire Barrier)	3048995

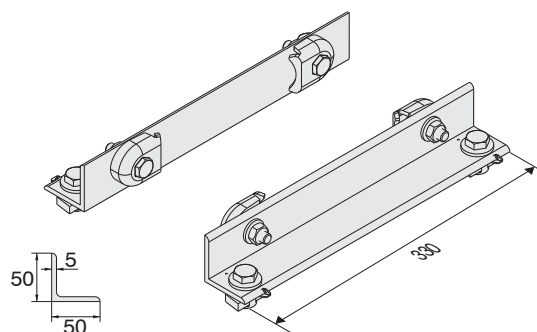

Description	Code
KO-II Horizontal Busbar Support Set	3116749

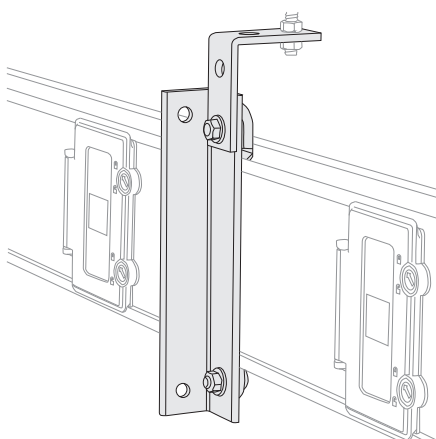
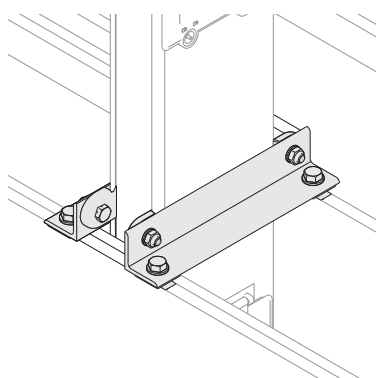
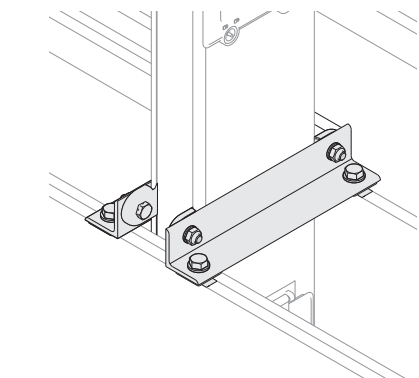
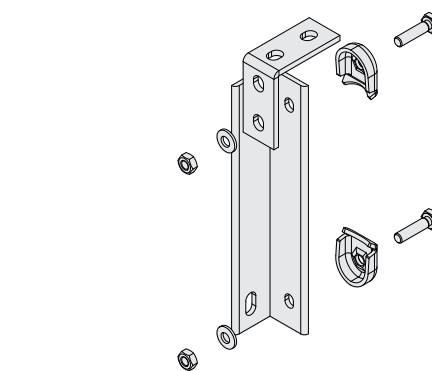

### Tray Supports

Description	L (mm)	Code
UAS-K4 SUPPORT (1)	200	3005333
UAS-K4 SUPPORT (2)	250	3005332
UAS-K4 SUPPORT (3)	300	3005331
UAS-K4 SUPPORT (4)	350	3005330
UAS-K4 SUPPORT (5)	400	3005329
UAS-K4 SUPPORT (6)	500	3005328
UAS-K4 SUPPORT (7)	600	3005327
UAS-K4 SUPPORT (8)	700	3005326
UAS-K4 SUPPORT (9)	1100	3005325

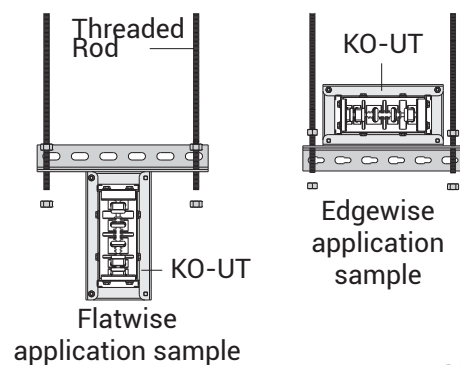
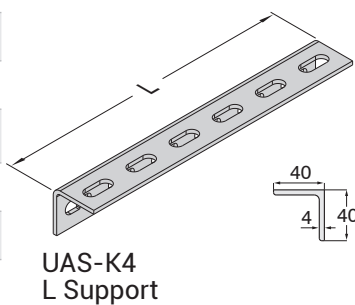

# E-LINE KO-II

## Fixing Elements



### Tray Supports

Description	L (mm)	Code
ASU2A-1	135	3008589
ASU2A-2	250	3008587
ASU2A-3	500	3008585
ASU2A-4	1000	3008583
ASU2A-5	2000	3008168

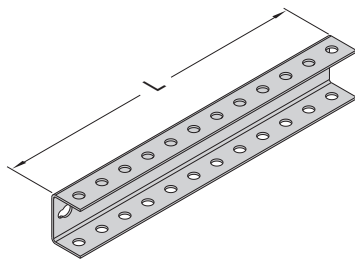

ASU2A

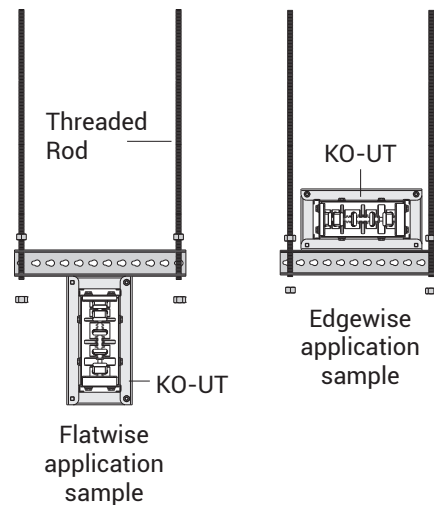
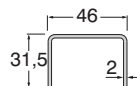

### Connection Parts

Description	L (mm)	Code
BRA 11-05 Threaded Rod (M8)	500	5000039
BRA 11-10 Threaded Rod (M8)	1000	5000038
BRA 12-05 Threaded Rod (M10)	500	5000037
BRA 12-10 Threaded Rod (M10)	1000	5000032
BRA 10 Extension Part (M8)	2000	1004313
BRA 13 Extension Part (M10)	-	1004312
BRA 9 EAE Pull-off Dowel (M8)	-	5000033
BRA 9 EAE Pull-off Dowel (M10)	-	5000023
M8 Steel Nut	-	1000521
M10 Steel Nut	-	1000522
M8 Washer	-	1000502
M10 Washer	-	1000504

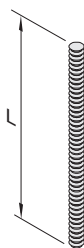

Threaded Rod



Extension Part



EAE Pull-off Dowel



Steel Nut



Washer

Current (A)	Aluminium (A) mm	Copper (A) mm
160	70	-
250	75	70
315	80	75
400	100	80
500	112	-
600	125	100
800	160	125

Busbar cross-section dimensions

Diameter of the hole to be drilled  
M8.....Ø12  
M10.....Ø14

Description	Current	A (mm)	Code
KOA - 1 UT Clamp	160	115	1004275
KOA - 2 UT Clamp	250	120	1004278
KOA - 3 UT Clamp	315	125	1004274
KOA - 4 UT Clamp	400	145	1004277
KOA - 5 UT Clamp	500	157	1004265
KOA - 6 UT Clamp	600	170	1004276
KOA - 8 UT Clamp	800	205	1007573
KOC - 2 UT Clamp	250	115	1004275
KOC - 4 UT Clamp	400	125	1004274
KOC - 6 UT Clamp	600	145	1004277
KOC - 8 UT Clamp	800	170	1004276

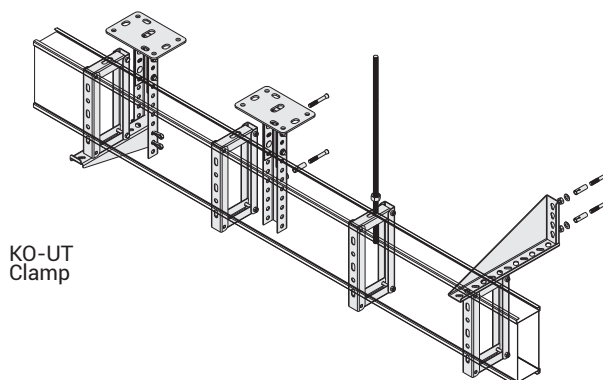
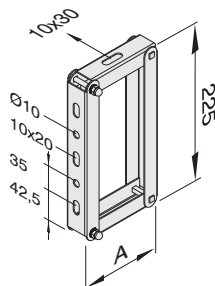

■ The span between supports should be 1.5m

# E-LINE KO-II

## Fixing Elements



Description	A (mm)	Code
KT 200 Tray Support	235	3008567
KT 250 Tray Support	285	3008565
KT 300 Tray Support	335	3008563
KT 400 Tray Support	435	3008561
KT 500 Tray Support	535	3008559
KT 600 Tray Support	635	3008264
TS 200 Tray Support	205	3008551
TS 250 Tray Support	255	3008549
TS 300 Tray Support	305	3008547
TS 400 Tray Support	405	3008545
TS 500 Tray Support	505	3008543
TS 600 Tray Support	605	3005828
TMP 8 Ceiling Support Unit	-	3008382
Coupling	-	1004310

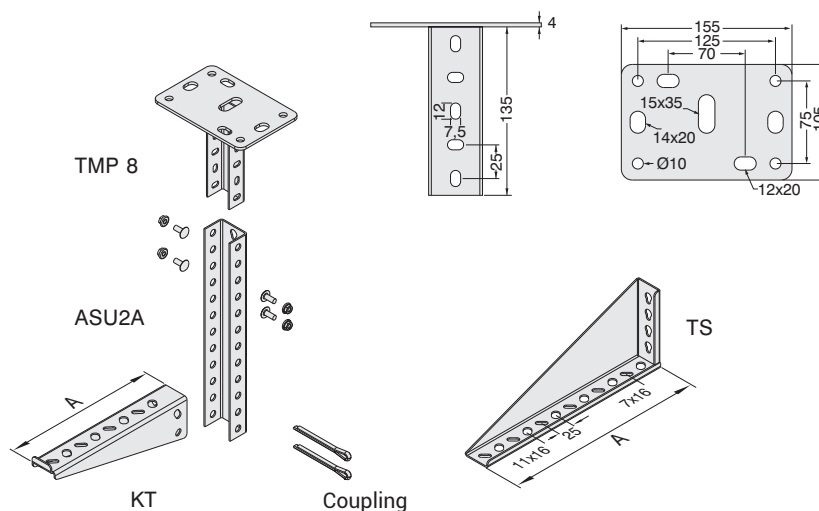

Description	Code
Vertical Support Set Wall Type	3025371

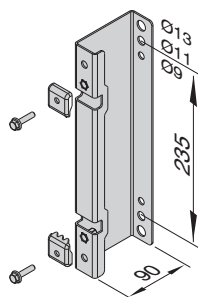

Vertical Support Set Wall Type

Description	Code
Vertical Support Set (Z) Type	3025376

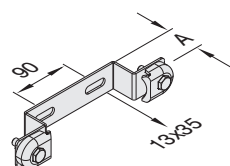

Vertical Support Set (Z) Type

Description	Code
Vertical Support Set (VS)-40	3025379
Vertical Support Set (VS)-60	3025378

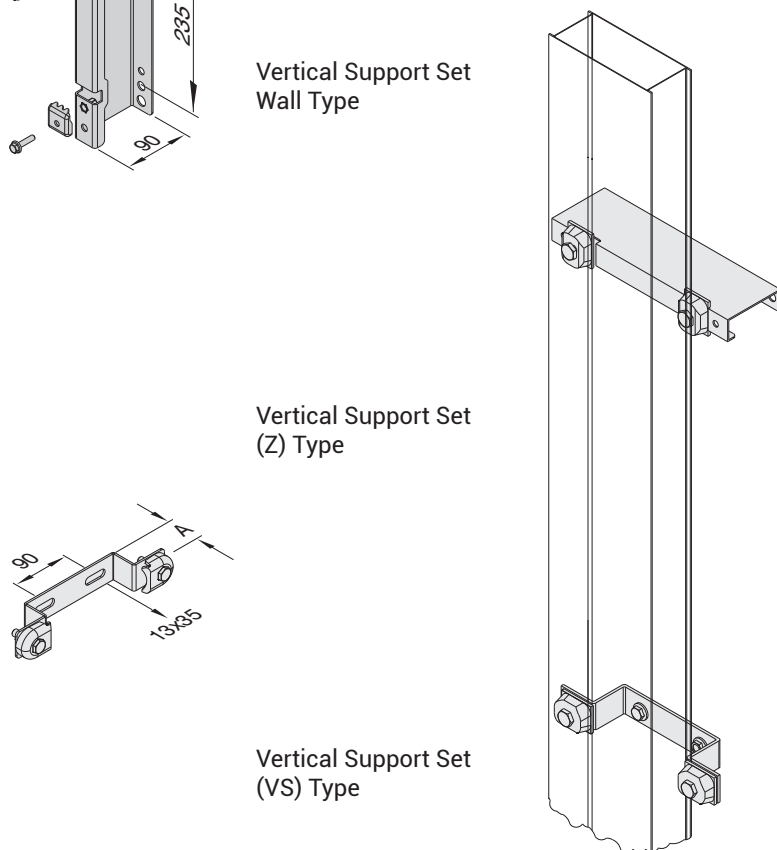

Vertical Support Set (VS) Type

■ The span between supports should be 1.5m

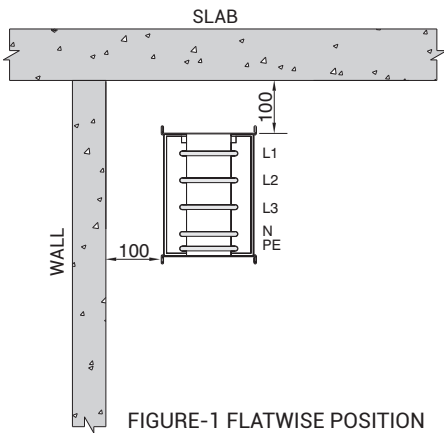

FIGURE-1 FLATWISE POSITION

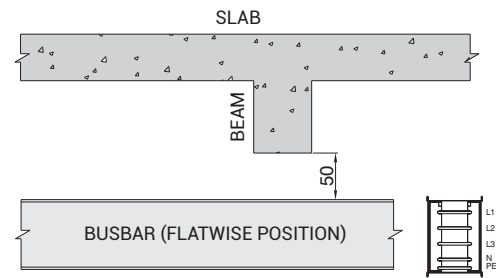

FIGURE-4 SAMPLE WALL CROSSING WITH FIRE BARRIER

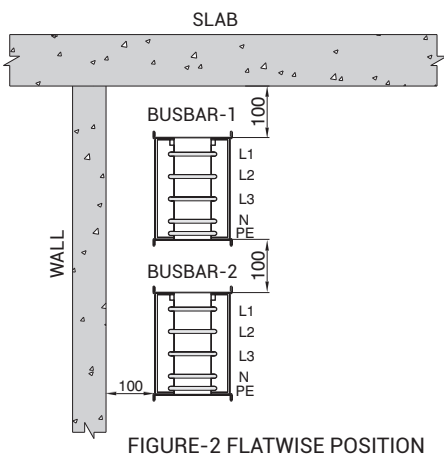

FIGURE-2 FLATWISE POSITION

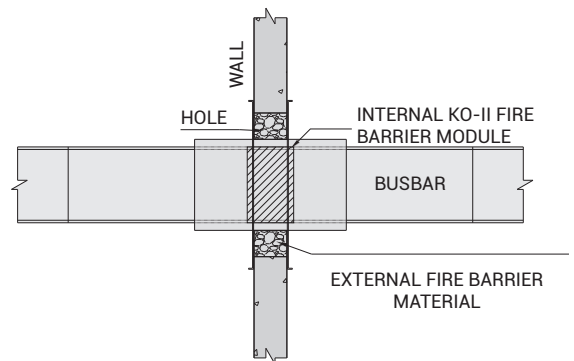

FIGURE-5 CROSSING UNDER A BEAM HORIZONTAL POSITION

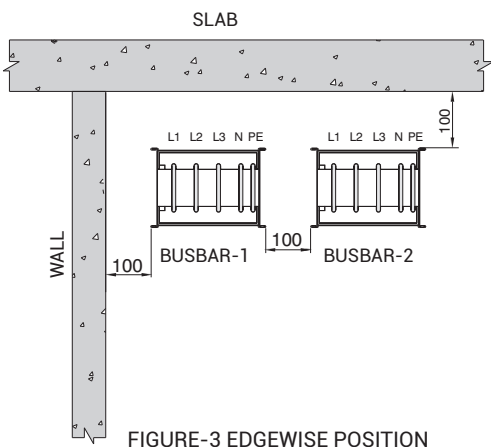

FIGURE-3 EDGEWISE POSITION

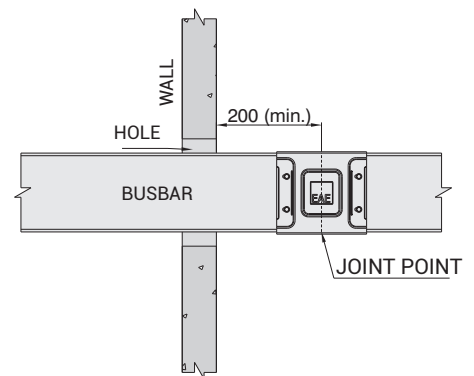

FIGURE-6 STANDARD WALL CROSSING

■ The span between supports should be 1.5m ■ The dimensions given above are minimum values. All dimensions are given in mm.

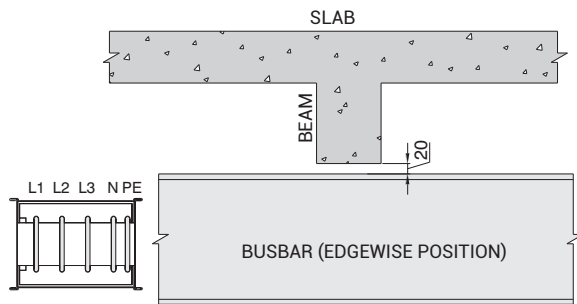

FIGURE-7 CROSSING UNDER A BEAM EDGEWISE POSITION

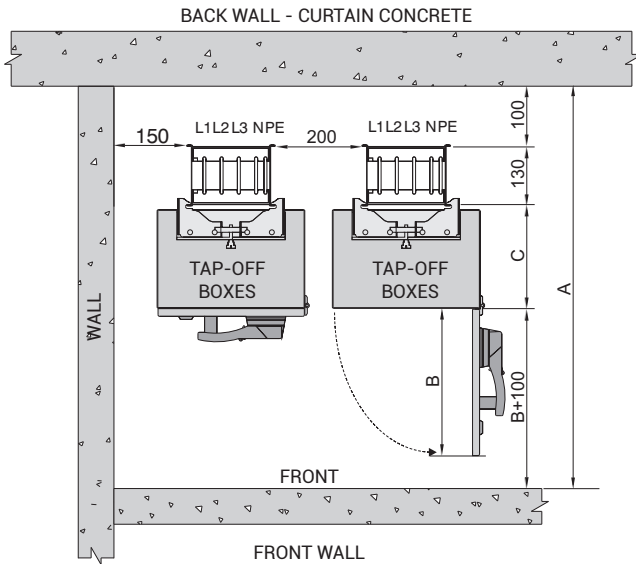

FIGURE-8 MINIMUM DIMENSIONS BETWEEN 2 TAP-OFF BOXES

**NOTE :** To determine the busbar layout in correct shaft measurement  
 $A = B + C + 330$

- A = Min distance from front wall
- B = Distance to open the cover of Tap off box
- C = Depth of Tap off box

### Application of Tap off box on vertical lines

Neutral conductor position in housing should be on rightside from front view at vertical lines.

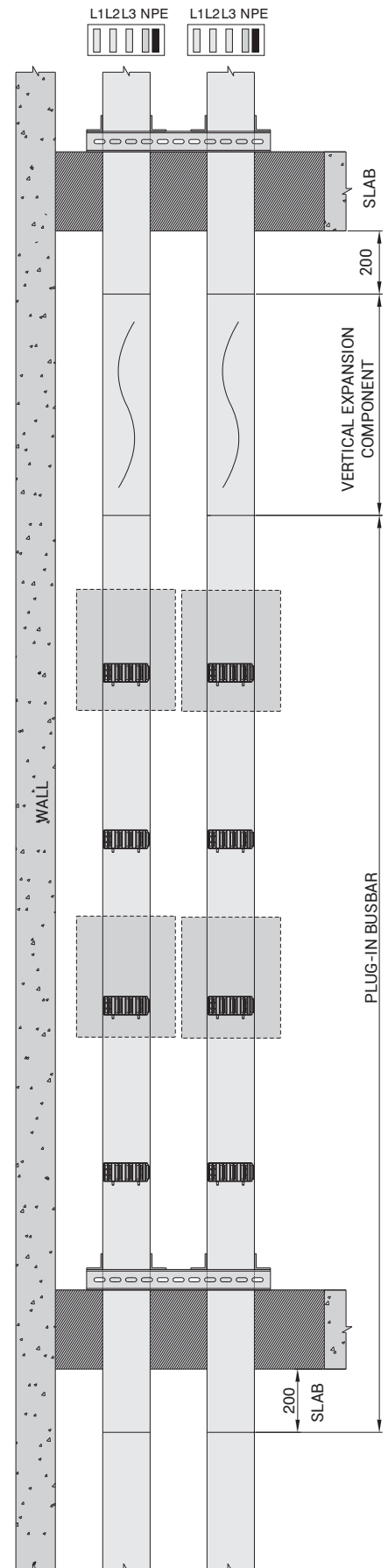

FIGURE-9 MINIMUM DIMENSIONS ON SHAFT APPLICATIONS

■ The span between supports should be 1.5m ■ The dimensions given above are minimum values. All dimensions are given in mm.

### Horizontal expansion module ( YDT ) application

It is used for longer horizontal runs as per the pictures shown below (Picture-1)

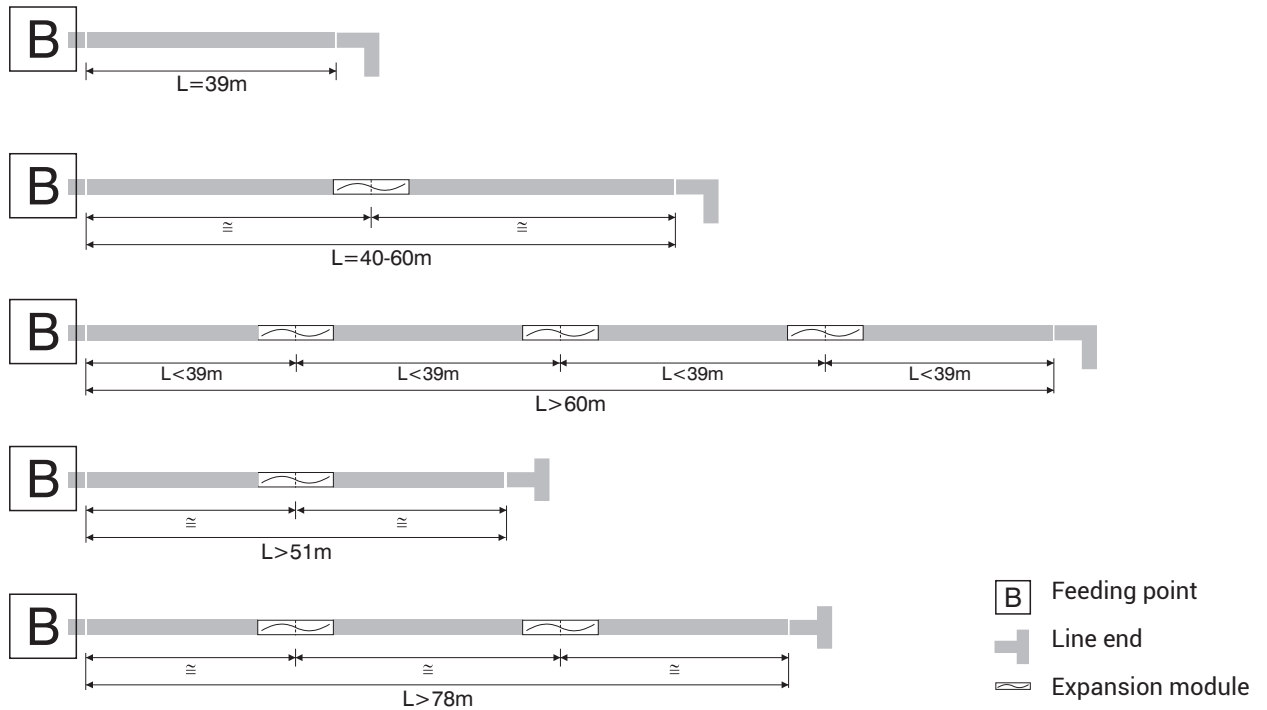

FIGURE-1 YDT APPLICATION

It is essential that a YDT is used if busbar runs cross a building expansion joint

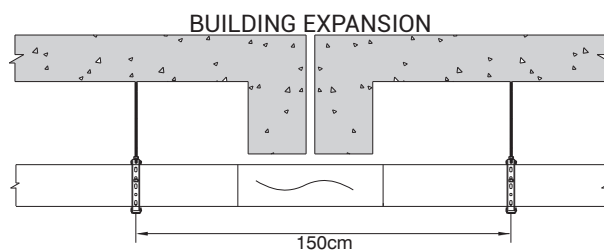

FIGURE-2 YDT BUILDING EXPANSION APPLICATION

### Vertical expansion module ( DDT ) application

- 1-) DDT is used for vertical lines of multistorey buildings .
- 2-) DDT is used between two fixed supports at every floor crossing.

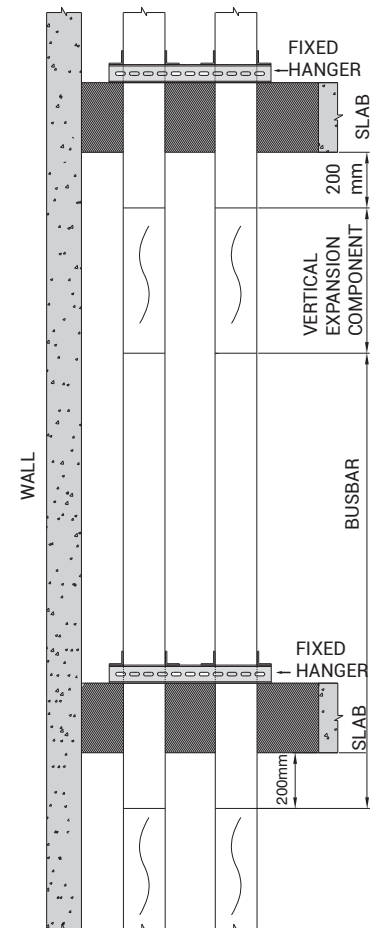
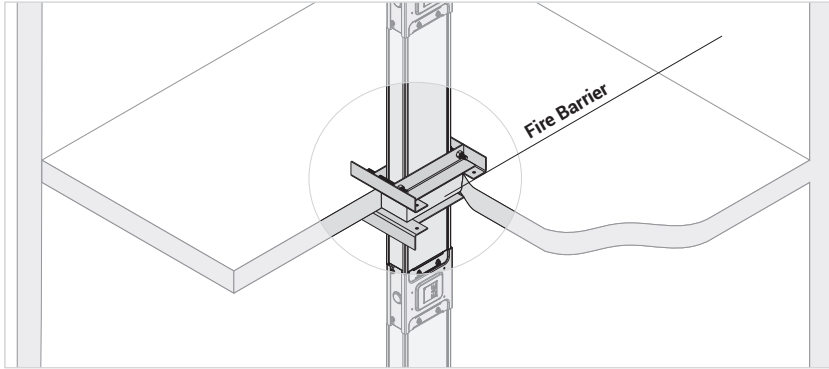
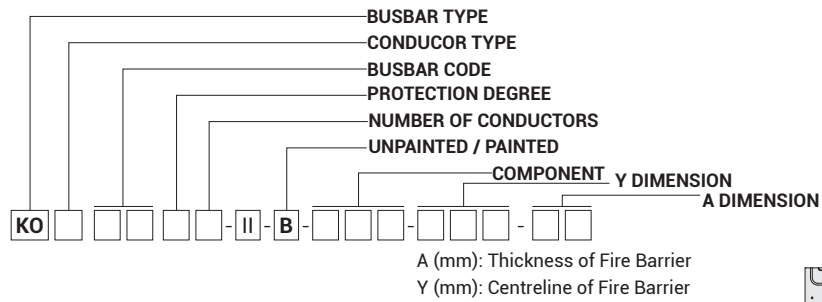

FIGURE-3 DDT APPLICATION

# E-LINE KO-II

## Fire Barrier



Sample Order:  
 250 A, Copper, IP 55, 5 Conductors  
 Fire Barrier  
**KOC 0255- II -STD-150-40**

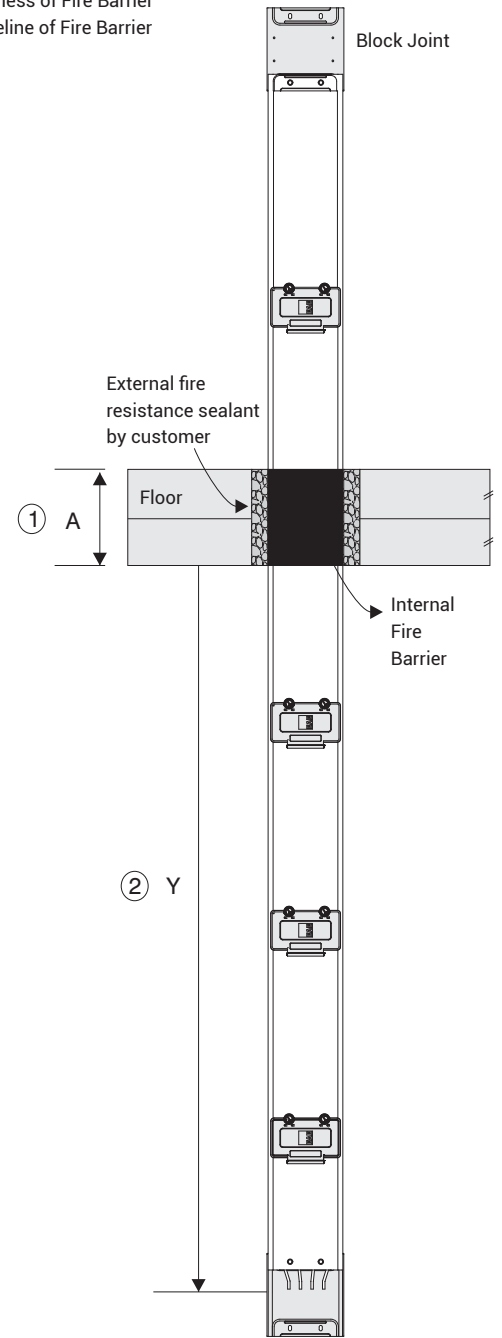

### Fire Barriers

Fire barriers are used to prevent the transition of flame and smoke from one zone to another in case of fire. The fire barriers prevent the chimney effect of air insulated busbar.

### Dimensioning of Fire Barrier

When placing an order for fire barriers to be installed in the KO-II busbar, the following information is required :

- 1- Thickness of floor or wall in cm. (A mm)
- 2- Centreline dimension of the fire barrier should be measured from the side without the block joint. (Y mm)
- 3- There will be no plug-in points at the fire barrier location.
- 4- EAE Supplies a 300 mm thick fire barrier as standard when wall or floor thickness is not stated.
- 5- The minimum length for these special elements with fire barrier is 600 mm.

### Determination of Special Lengths

After the installation of standard 3m lengths, special lengths shorter than 3m may be required. The minimum length for these special lengths is 350 mm. Please measure these special lengths as shown below.

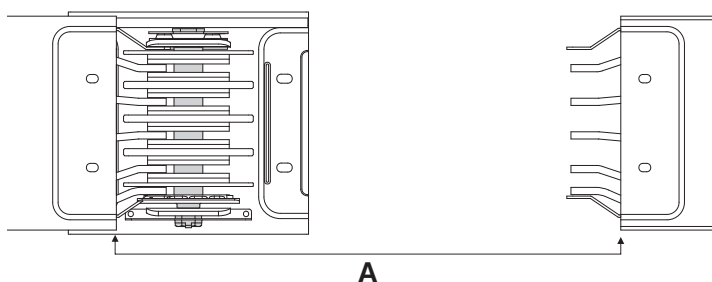

Measure "A" length in cm, to determine the length of special busbar subtract 12 from "A".

$$X = A - 120 \text{ (mm)} \quad X = \text{Length of Special Busbar}$$

# E-LINE KO-II

## KO-II Installation of End Closer

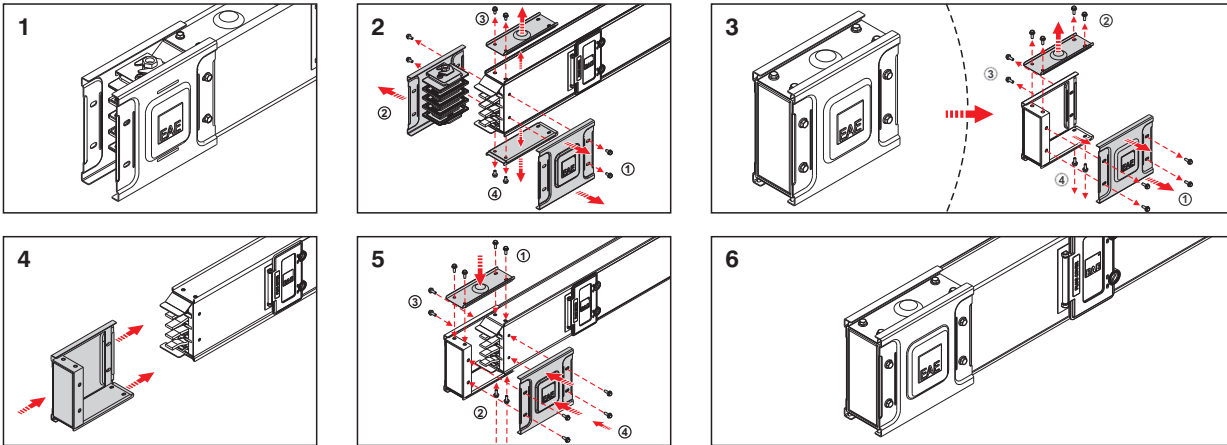

### KO-II Mounting instructions for Joints

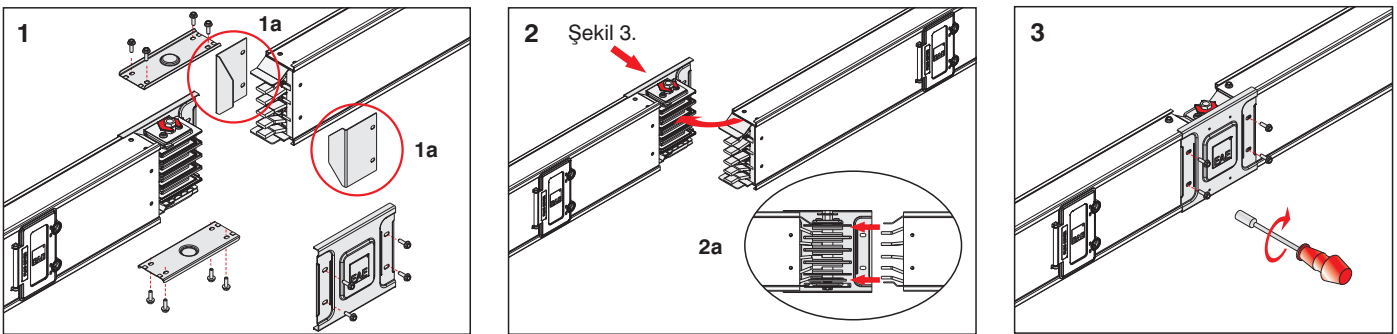

1- Remove joint top cover plate, joint side cover plate and the screws from non-block joint bolt. (Pieces marked as 1a should be thrown away.)

2- Introduce bolted and non-bolted ends of the busbar into each other carefully, until the cover plate screws can be put in.

3- Fix the joint side cover of the block joint.

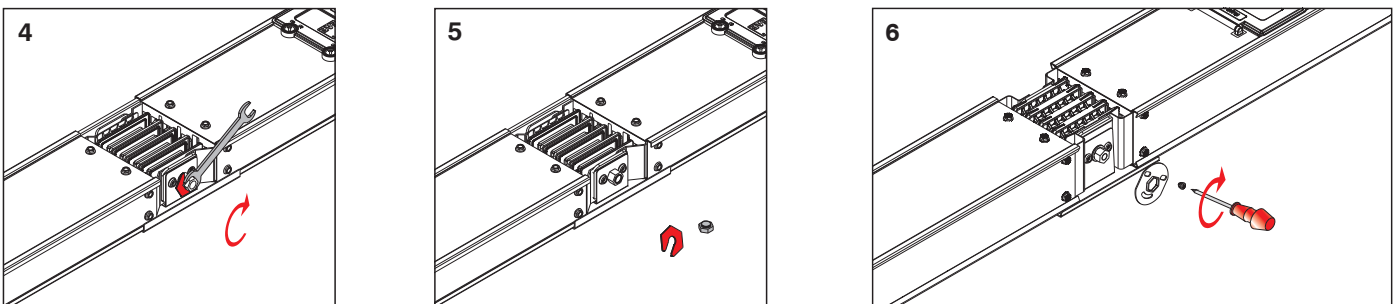

4- Tighten the double headed nut until upper nut is broken.

5- Take away the broken nut and plastic separator.

6- Place the nut locking plate over the nut and secure it in the existing bolt slot.

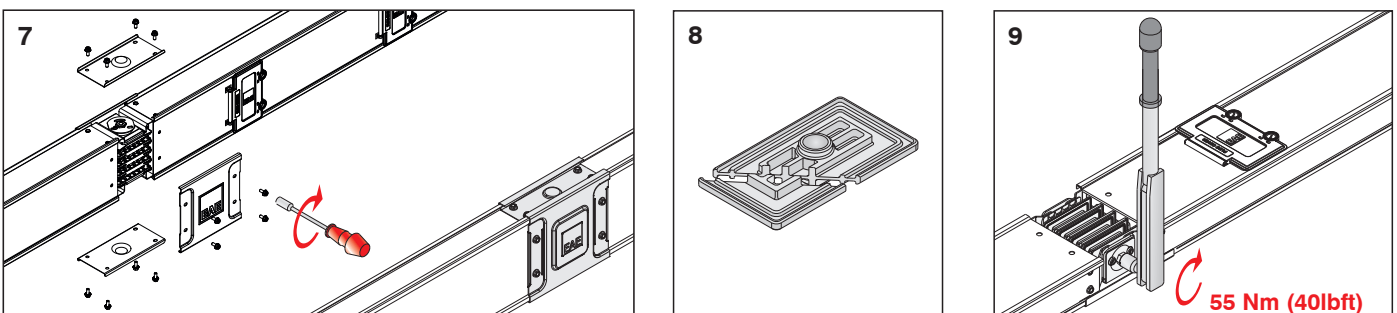

7- Install top and bottom joint cover plates. Check the joint before fitting the last joint side cover plate. Fit the joint cover side plate and tighten the screws. Check the position of the earth conductor when installing KO-II with five conductors.

8- Ensure that the insulation plates of the joint, are not cracked or broken.

9- If removal is required for any reason, tighten the nut using a calibrated torque wrench adjusted to 55 Nm (40 lbf) after re-fitting the block joint set.

## CE DECLARATION OF CONFORMITY

**Product Group** E-Line KO-II Busbar Energy Distribution System

**Manufacturer** EAE Elektrik Asansor End. Insaat San. ve Tic. A.S.  
Akcaburgaz Mahallesi, 3114. Sokak,  
No:10 34522 Esenyurt-Istanbul-Turkey

The objects of the declaration described below is in conformity with the relevant Union harmonisation legislation. This declaration of conformity is issued under the sole responsibility of the manufacturer.

**Standard:**

**EN 61439-6**

Low-voltage switchgear and controlgear assemblies - Part 6: Busbar trunking systems

**CE - Directive:**

2014/35/EU "The Low Voltage Directive"

2014/30/EU "Electromagnetic Compatibility (EMC) Directive"

2011/65/EU "Restriction of the use of certain hazardous substances (RoHS)"

**Technical Document Preparation Official:**

EAE Elektrik Asansor End. Insaat San. ve Tic. A.S.  
Akcaburgaz Mahallesi, 3114. Sokak, No:10 34522 Esenyurt-Istanbul-Turkey

Mustafa AKÇELİK

**Date**

20.04.2024

**Document Authorized Signatory**

**Elif Gamze KAYA OK**  
**Deputy General Manager**



	<h1 style="text-align: center;">CERTIFICATE</h1> <p>EAE Elektrik Asa Insaat San. ve Ti Akçaburgaz Mah 34510 Esenyurt Turkey</p>	
	<p>For the product: Low-voltage busbar trunking system</p> <p>EAE CRA06</p> <p>Ue 1000 V, Ui 10 IP68, IK: 50J, for</p> <p>EAE Elektrik Asa Insaat San. ve Ti Akçaburgaz Mah 34510 Esenyurt Turkey</p> <p>Design verificatio</p>	 <p>icw 20 kA – 1 s</p>
	<p>Requirements: IEC 61439-6: 2012; Clauses: 10.2.3, 10.2.6, 10.2.7, 10.2.101, 10.3, 10.4, 10.5, 10.9, 10.10, 10.11 and Annex BB, CC, and DD</p> <p>Busbar trunking s</p> <p>joint and straight le</p> <p>is granted on acco</p> <p>1.01-INC, dated 31</p> <p>s been carried out c</p> <p>ntestation does not</p> <p>duction with the sp</p> <p>13</p>	 <p>DEKRA, the results</p> <p>the product, submi</p> <p>the manufacturer's</p> <p>is not the responsi</p> <p>100</p>
	 <p>n B.V.</p> <p>jer</p> <p>his certificate and adjoin</p>	

DEKRA Certification B.V. Utrechtseweg 310, 6812 AR Arnhem P.O. Box 5185, 6802 ED Arnhem, The Netherlands  
T +31 88 96 83000 F +31 88 96 83100 www.dekra-certification.com Company registration 09085396

#### 1- Standards & Certification:

- Busbar system shall be designed and manufactured as per IEC 61439-6 standard. Each individual rated busbar shall have separate type test certificate from an independent internationally accredited laboratory.
- Manufacturing facility of busbar systems shall have ISO 9001 and ISO 14001 certification.
- Busbar system shall have CE marking.
- Each product shall have a "Type Label", which indicates the brand, type of the unit, conductor number and electrical details.

#### 2-General Structure of Products:

- Busbar system shall be Air-Insulated and Plug-in type. Aluminium or Copper conductors shall be tin plated along the entire length. Housing shall be galvanized steel or if required RAL 7038-Electrostatic painted.

#### 2.1- Electrical Characteristics:

- Busbar systems nominal insulation voltage shall be 1000V.
- As per ampere rates, minimum short circuit values shall be like below:

For Aluminium Conductor;	For Copper Conductor;
160A: 1sec/rms-10kA, Peak-17kA	250A - 315A: 1sec/rms-18kA, Peak-36kA
250 and 315A: 1sec/rms-15kA, Peak-30kA	400A: 1sec/rms-25kA, Peak-52,5kA
400 and 500A: 1sec/rms-30kA, Peak-63,5kA	600A and above: 1sec/rms-35kA, Peak-73,5kA
600A and above: 1sec/rms-35kA, Peak-73,5kA	

#### 2.2- Housing and Structure:

- Busbar system shall be of air insulated type. The bars shall be supported by insulators installed into the housing at every 25 cm.
- On a three meter standard length busbar the distance between the plug-in points on one side shall be 50cms. The points shall be on both sides of the busbar making the average distance of plug-in points 25cm.
- To prevent wrong alignment of the phase sequence during installation there shall be mechanical barriers on the joint that shall ensure correct mounting.
- IP Plug-in covers of the busbar system should be hinged. Plug-in windows shall have automatic shutter system. This shutter shall open automatically when the earth contact of tap-off box is inserted.
- Busbar system shall have all necessary accessories (elbows, offsets, panel-transformer connections, reductions, etc). Manufacturer shall supply special dimensioned units in short time, if the project conditions requires.
- For horizontal runs, a horizontal expansion unit shall be used at every 40m and expansion points of the building.
- For vertical applications, a vertical expansion unit shall be used at every floor. Busbar system shall be rigidly fixed by supports at every floor.

#### 2.3-Conductors:

- Busbar system shall have Nickel and Tin-plated 6101 class aluminium conductors (160-800A). / Busbar system shall have Tin-plated Electrolytic copper conductors (250-800A).
- Busbar system shall have below number of conductors and phase configuration;

- a) 4 Conductors : (4 full size conductors + Housing ( earthing )
  - b) 4 ½ Conductors : (4 full size conductors + ½ earth conductor + Housing)
  - c) 5 Conductors : ( 5 full size conductors + Housing (earthing) )
  - d) 5 Conductors : ( 5 full size conductors, 5th bar shall be used as clean earth + Housing).
- Neutral conductor shall have the same cross-section (100%) of phase conductors.

#### 2.4- Insulation:

- Busbars shall have air-insulation system.
- Rated insulation voltage of the system shall be 1000 V.

#### 2.5- Joint Structure:

- Electrical and mechanical connection shall be made at joints by "single bolt" joint construction and each joint shall have two "Belleville" washers.
- Insulators of the joint shall be manufactured of glass-reinforced polyester.
- Joints shall be realized by a torque spanner (wrench) set at 55 Nm.
- To prevent the joints from transportation damages, they shall be protected by metal caps, which shall be removed before installation.
- Joint bolt shall be locked from both sides (Bolt head and nut).

#### 2.6- Protection:

- Protection degree of the busbar system shall be minimum IP55.

#### 3- Tap Off Boxes:

- Rating of plug-in tap off boxes shall be up to and including 400A. Plug-in tap off boxes shall be installed, when the busbar line is energized.
- Tap off boxes shall have an electrical interlock mechanism, which ensures that plug-in tap off box cannot be removed mechanically from the busbar, when the switch is at "ON" position. Mechanical interlock mechanism shall prevent the cover of the box from opening, when the switch is at "ON" position.
- When the switch is at "OFF" position and the cover is open, tap off box shall provide IP2X protection level. (There shall not be any accessible live part in the box).
- Tap Off boxes shall be suitable for any brand of MCB.
- Contacts of plug-in tap off box shall be silver-plated copper.
- While inserting the contacts of Plug-in tap off boxes, earth contact shall make first contact.
- Tap off boxes up to 80A shall be manufactured of (850 GLW) type plastic material. Tap off boxes from 160A up to 400A shall be manufactured of sheet steel and epoxy painted RAL 7035.

#### 4- Installation and Commissioning:

- Busbar systems shall be installed as per single-Line drawings respect to required ampere rates and manufacturer installation guide (torque values, lockers, etc.).

Electrical installer shall run an insulation test after installation according to manufacturer's test procedures. The results of the test shall be reported to the manufacturer.

Minimum insulation value shall be 1Mohm.

---

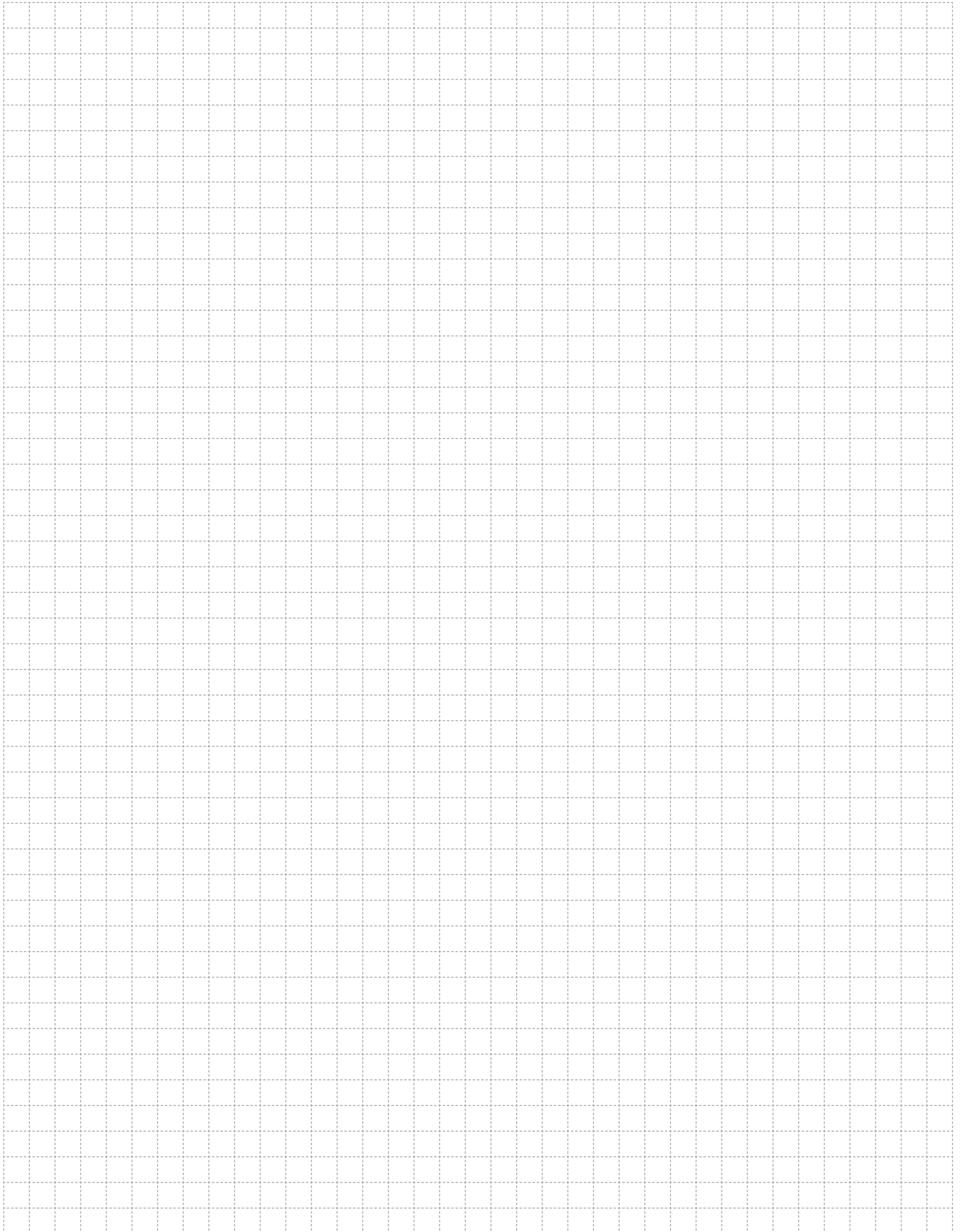

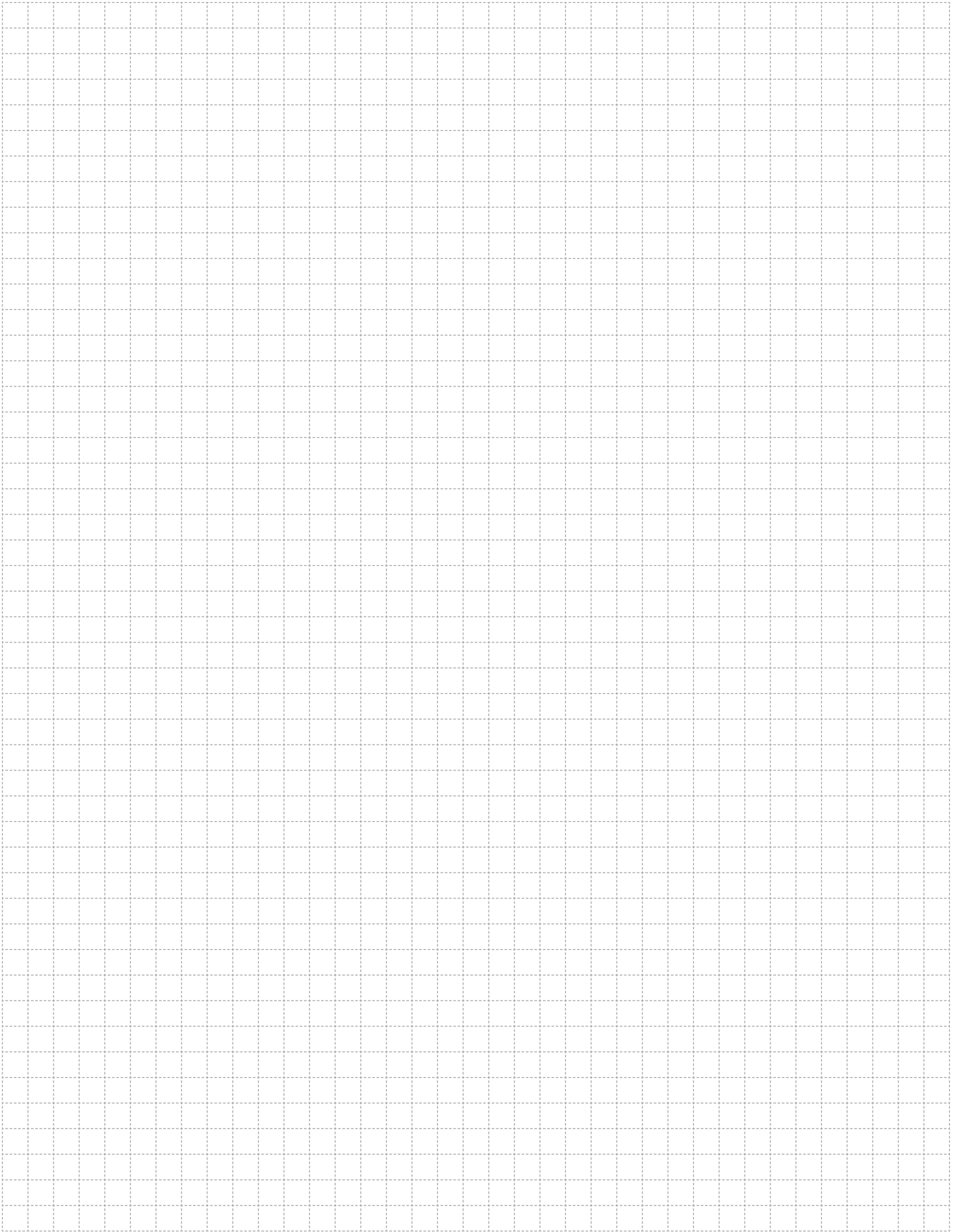

A large grid area for taking notes, consisting of a 20x30 grid of small squares.

---

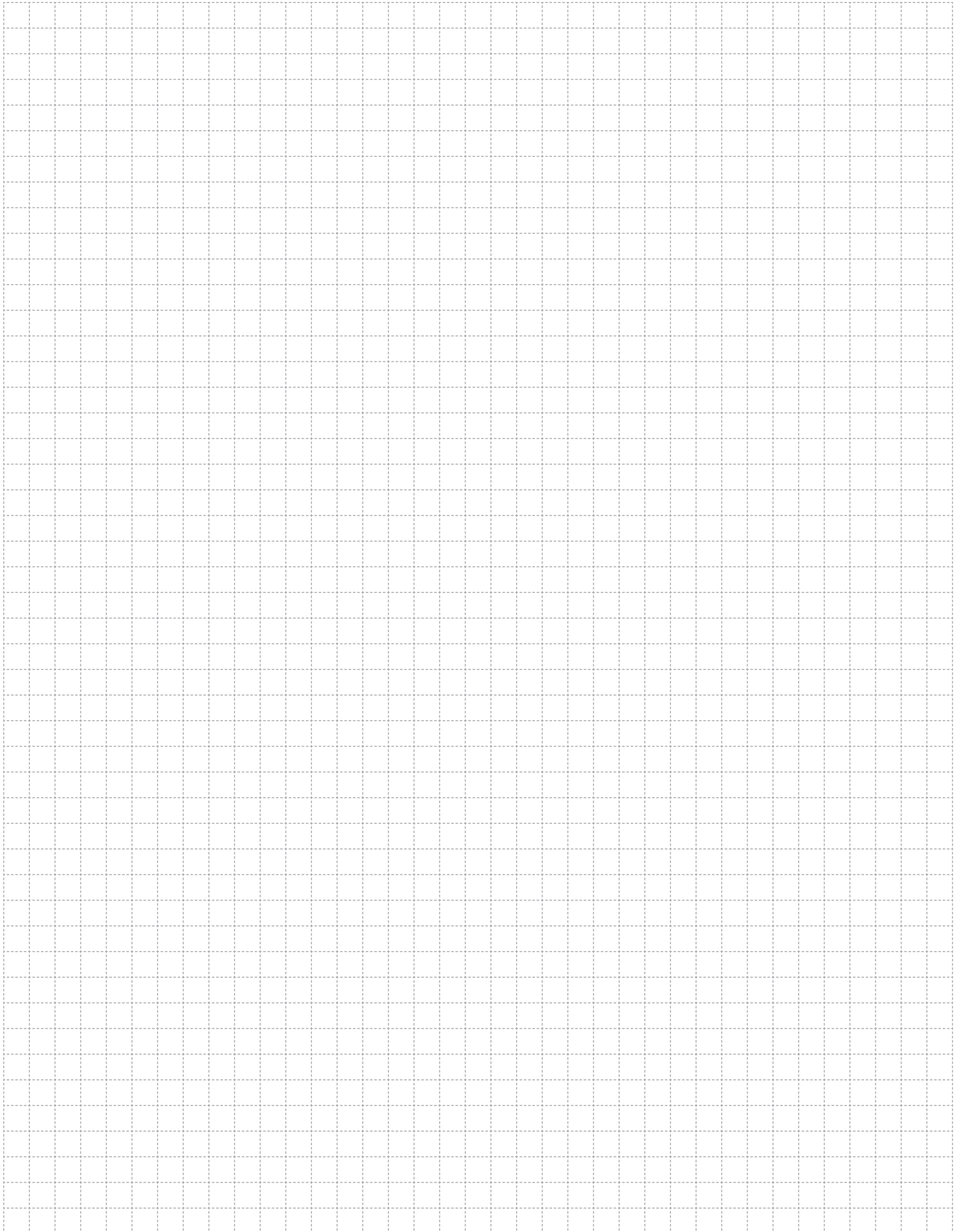

# SUSTAINABLE FUTURE

## Sustainability Management at EAE Elektrik



As part of our goal to support sustainable development and green transformation, measuring, evaluating, and managing all economic, environmental, and social impacts resulting from our sustainability practices is a key governance priority for EAE Elektrik. We act with great care in analyzing, monitoring, and managing the economic, environmental, and social impacts and risks that arise throughout our value chain in both our national and global operations.

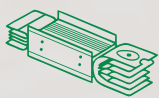

Busbar Systems

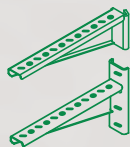

Support Systems

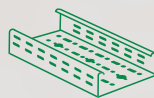

Cable Tray Systems

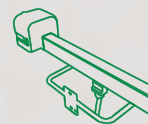

Trolley Busbar Systems



Fit-Out Solutions

*"We are working together with all our stakeholders to develop the electrical technologies that will build the future."*

You can visit our sustainability website at [sustainability.eaeelectric.com](https://sustainability.eaeelectric.com)



#FutureTogether

**EAE Elektrik**  
**Head Office**

Akcaburgaz Mahallesi,  
3114. Sokak, No: 10 34522  
Esenyurt - Istanbul - Turkiye  
Tel: +90 (212) 866 20 00  
Fax: +90 (212) 886 24 20

**EAE DL 3 Factory**  
**Busbar**

Organize Sanayi Bolgesi Mahallesi,  
6. Cadde, No: 6A, 41455  
Dilovasi - Kocaeli- Turkiye  
Tel: +90 (262) 999 05 55  
Fax: +90 (262) 502 05 69



Please visit our website for the updated  
version of our catalogues.  
[www.eaelectric.com](http://www.eaelectric.com)



Catalogue 13 - En. / Rev.17 -- Pcs. 15/04/2026  
D.S.

EAE has full right to make any revisions or changes on this catalogue without any prior notice.