



E-LINE KY-S

BUSBAR SYSTEMS 25-40-63A

www.eaelectric.com

EAE GROUP IN NUMBERS



Since 1973

EAE Group of Companies started its journey in the electrical sector in 1973 with the establishment of EAE Elektrik. Since its founding, EAE has grown rapidly, expanding its production and areas of operation by incorporating EAE Lighting in 1983, EAE Machinery in 1996, EAE Electrotechnics in 2004, and EAE Technology in 2009.

EAE carries out its production activities in accordance with ISO 9001 Quality Management, ISO 14001 Environmental Management, ISO 14064-1 Greenhouse Gas Management System, ISO 45001 Occupational Health and Safety Management, ISO 10002 Customer Satisfaction Management, ISO 50001 Energy Management System, and ISO 27001 Information Security Management System standards.



50+
Years Experience



8
Active Factories



370.000m²
Enclosed Space



3
R&D Centers



150+
Countries Exported To

CONTENTS

General Overview	2-3
Technical Characteristics	4
Order Code System	5
KY-S Busbar Conductor Structure and Addressing Types (Key Plan)	6
KY-S Busbar Selection Tables	7-8
KY-S DALI Busbar Selection Tables	9
KY-S Busbar Tap-Off Plug Selection Tables	10-13
KY-S DALI Busbar Tap-Off Plug Selection Tables	14-15
KY-S Busbar Tap-Off Box Selection Tables	16-20
Head Feeder Module (B1) Selection Table	21
End Feeder Module (B2) Selection Table	22
Flexible Elbow (FD) Module Selection Table	23
Busbar and Fitting Brackets (KY-S)	24-26
KY-S Accessories	27
KY-S Busbar Joint Installation / Single Tap-Off Plug Installation	28
KY-S Busbar Tap-off Plugs with clips/Cylindrical Fuse Installation	29
KY-S Busbar Miniature Circuit Breaker (MCB) Tap-Off Box Installation	30
KY-S Busbar Tap-Off Box with Cartridge (Cylindrical) Fuse Installation	31
KY-S Busbar C6 (5 Conductors) Principle Connection Circuit Diagram with Residual Current Device (RCD)	33
KY-S DALI Busbar C10 (6 Conductors) Principle Connection Circuit Diagram	34
KY-S DALI Busbar C9 (5 Conductors) Principle Connection Circuit Diagram with Residual Current Device (RCD)	35
KY-S DALI Busbar C8 (4 Conductors) Principle Connection Circuit Diagram	36
KY-S DALI Busbar C11 (6 Conductors) Principle Connection Circuit Diagram	37
E-LINE KY-S Busbar Product Overview	38
E-LINE KY-S Busbar CE Declaration of Conformity	39
KY-S Busbar Product Group	40

E-LINE KY-S

General Overview

E-Line KY-S Busbar Distribution Systems are used in building electrical installations with a power requirement of 25-40-63A. Due to the specifications of 10 and 16A tap-off plugs and 32A tap-off boxes, they are designed to supply lighting and wall socket circuits and small electrical machines and devices. The protection degree is IP55 when the covers of opening points are closed.

EAE Busbar Systems are produced using the world's latest manufacturing technologies, in accordance with ISO 9001 Standards and with a certified Quality Assurance System. Units are designed and tested according to IEC 61439-6. In standard production, the busbar housing is pre-galvanized sheet metal, and optionally, it can be manufactured in RAL 7038 colour.

- **3 and 1 Plug-in Openings in Standard 3m and 1m Lengths**
KY-S Busbar system is manufactured in two different standard lengths.

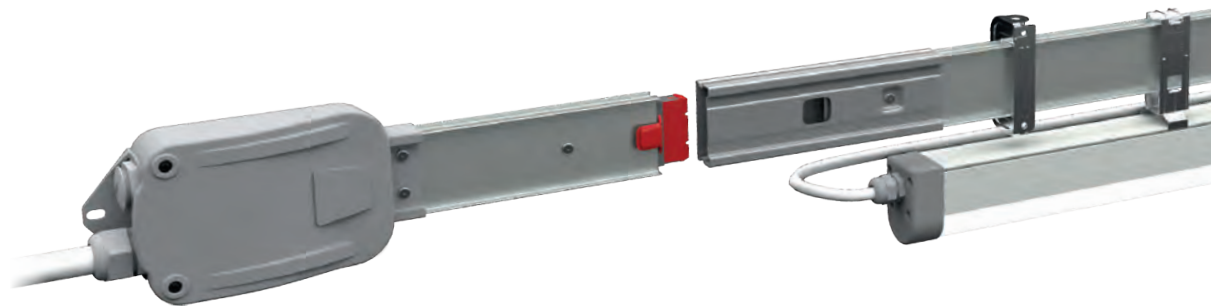
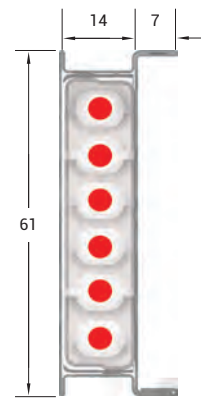
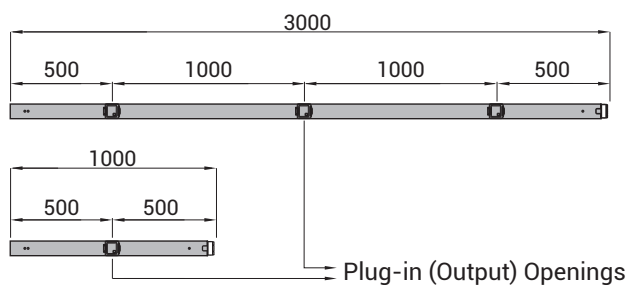

- **Tap-off Plugs and Boxes**
The Tap-off plugs of KY-S busbar systems are designed with different address structures in order to prevent misuse and shock. All plugs and boxes are manufactured to be connected to the busbar in one direction only. This prevents the use of a wrong phase.



- **Safety**
Earth contacts of the tap-off plugs and boxes make first when plugging-in, and the contact breaks last when unplugging.

- **Colours Indicating Plugs and Boxes**
In plugs and boxes, the colours of the cover, housing, ear and cable entry gland are designed in different colours so that you can easily see the phase, function and features. (See. Page: 10)





Insulation at Full Length

Busbar conductors are coated with full-length flame-proof insulation material. Full protection regarding human safety is provided even when the body is severely damaged due to external heavy impacts that may occur.

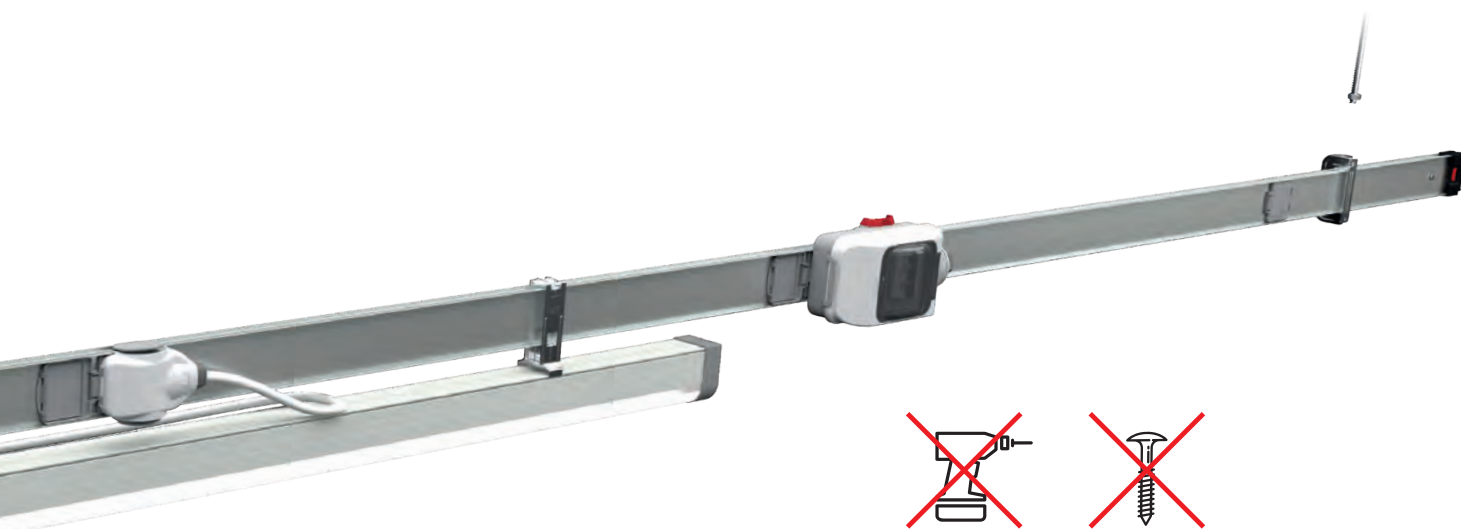

Fast, Easy and Secure Assembly

Mechanical and electrical continuity is achieved with a single action by driving the joint structure with silver-plated spring contacts into each other. You do not need to tighten any bolts to secure the locking. There is no need for any operation or tool for mounting the joint structure that prevents deflection and stretching.

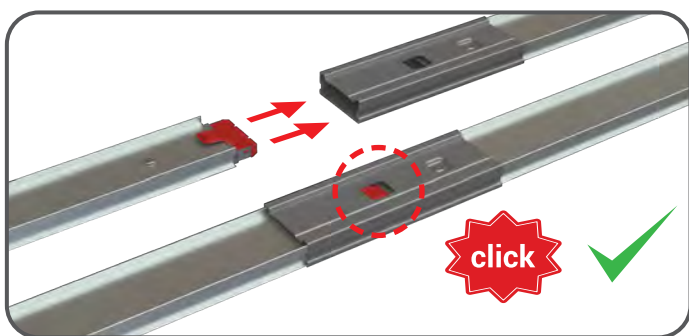

Tin-Plated Conductors and Contacts

Copper conductors are plated with tin in full-length, preventing the formation of Copper Oxide. With this process, contact resistances are minimized. Steel spring reinforced. With the jawed contact construction, the contacts of the tap-off plugs and boxes compress the conductor from two surfaces in the busbar.

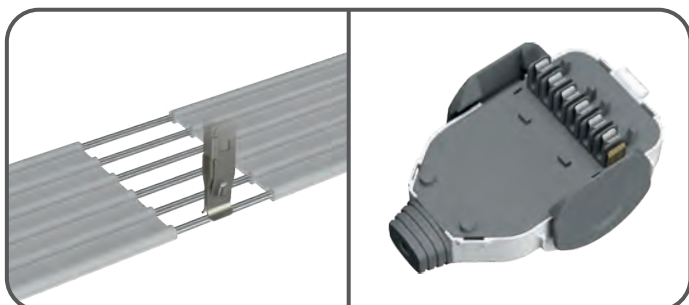

Silver-Plated Joint Contacts

The contacts at the busbar joints and the contacts of all tap-off units are silver-plated. The silver-plating minimises the contact impedances, thus preventing the over-heating of the contacts in case of possible over-loads.

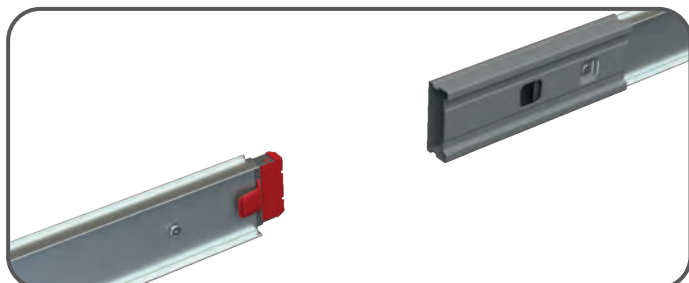

Rated Current		I_n	A	25	40	63			
	Busbar Code			2	4	6			
	Standards	IEC 61439-1/6, TS EN 61439-1/6							
	Rated Isolation Voltage	U_i	V	690	690	690			
	Operating Voltage	U_e	V	400	400	400			
	Rated Frequency	f	Hz	50-60	50-60	50-60			
	Operating Ambient Temperature	t	°C	-5/+50	-5/+50	-5/+50			
	Protection Degree (IP)	IP 55							
	Mechanical Impact Resistance (IK)	IK07							
	Rated Short-Time Current (0.1 s)	I_{CW}	$kA_{(rms)}$	2,5	3	4			
	Rated Peak Withstand Current	I_{pk}	kA	4	5	6,5			
CONDUCTOR CHARACTERISTICS AT RATED CURRENT In	Resistance (AC) at a conductor temperature of 20 °C	R_{20}	mΩ/m	7,387	3,793	2,4696			
	Resistance (AC) at an ambient air temperature of 35 °C	R_t	mΩ/m	8,903	4,8646	3,2727			
	Reactance (Independent from Temperature)	X	mΩ/m	1,010	0,6638	0,2177			
	Positive and negative sequence impedances at an ambient air temperature of 35 °C	Z_{35}	mΩ/m	8,903	4,9097	3,2800			
	Positive and negative sequence impedances at a conductor temperature of 20 °C	Z_{20}	mΩ/m	7,387	3,8510	2,4792			
	Rated Power Loss at 35 °C	P	W/m	16,7	23,4	39,0			
	DC Resistance at a conductor temperature of 20 °C for Phases	$R_{ort_{ph}}$	mΩ/m	7,203	3,900	2,697			
	DC Resistance at a conductor temperature of 20 °C for Neutral	R_N	mΩ/m	7,200	3,891	2,575			
	DC Resistance at a conductor temperature of 20 °C for PE	R_{PE}	mΩ/m	2,267	2,267	2,267			
	DC Resistance at a conductor temperature of 20 °C for Clean Earth	R_{PE}	mΩ/m	7,200	3,891	2,575			
HOUSING AND SECTIONS	L1, L2, L3, N	S_L	mm ²	2,54	4,9	8			
	CPE (5 Conductors)	S_{CPE}	mm ²	2,54	4,9	8			
	PE (Sheet Steel)	S_{PE}	mm ²	95	95	95			
	PE (Cu Equivalent-Sheet Steel)	$S_{PE(CU)}$	mm ²	7,60	7,60	7,60			
	Busbar Weight (2 conductors)	P	kg/m	1,026	1,066	1,118			
	Busbar Weight (3 conductors)	P	kg/m	1,056	1,115	1,193			
	Busbar Weight (4 conductors)	P	kg/m	1,086	1,164	1,264			
	Busbar Weight (5 conductors)	P	kg/m	1,016	1,213	1,345			
	Busbar Weight (6 conductors)	P	kg/m	1,146	1,262	1,415			
	Busbar Housing Dimensions	LxH	mm	54x13	54x13	54x13			
Temperature of Operating Environment (min/max)		t	°C	-5/+50	-5/+50	-5/+50			
VOLTAGE DROP				Three phase	Single phase	Three phase	Single phase	Three phase	Single phase
	Power factor (Cosφ) = 0.7	ΔU	Volt/m	0,186	0,215	0,138	0,159	0,158	0,182
	Power factor (Cosφ) = 0.8	ΔU	Volt/m	0,202	0,233	0,174	0,201	0,169	0,195
	Power factor (Cosφ) = 0.9	ΔU	Volt/m	0,225	0,260	0,188	0,217	0,186	0,215
	Power factor (Cosφ) = 1.0	ΔU	Volt/m	0,236	0,272	0,194	0,224	0,199	0,230
<p>*It is assumed that the voltage drop values are at full load (max. current) and the load is distributed on the line and they are given as values (Volt) per meter for different power factors (Cosφ).</p> <p>*If the entire load is at the end of the line, please find the end-of-line voltage drop by dividing the values given in the table by 0.66.</p> <p>*k=0,66 (Load distribution factor). $\left[k = \frac{n+1}{2n} \right]$ n = 3 (Number of tap-off in a standard 3 m busbar)</p>									
*Table values are given to facilitate basic calculations, and for exact values, calculations should be made according to IEC 60364-52, taking into account the project details.									

Allowable Mechanical Loading Table

Busbar Types KY-S	Fixing Element Intermediate Distance (L) (m)	Diagram	
		Single Point Suspended Load (F) (kg)	Distributed Load (F) (kg)
25A / 40A / 63A	1,5	60	66
	2,0	30	35
	3,0	10	12

E-LINE KY-S

Order Code System

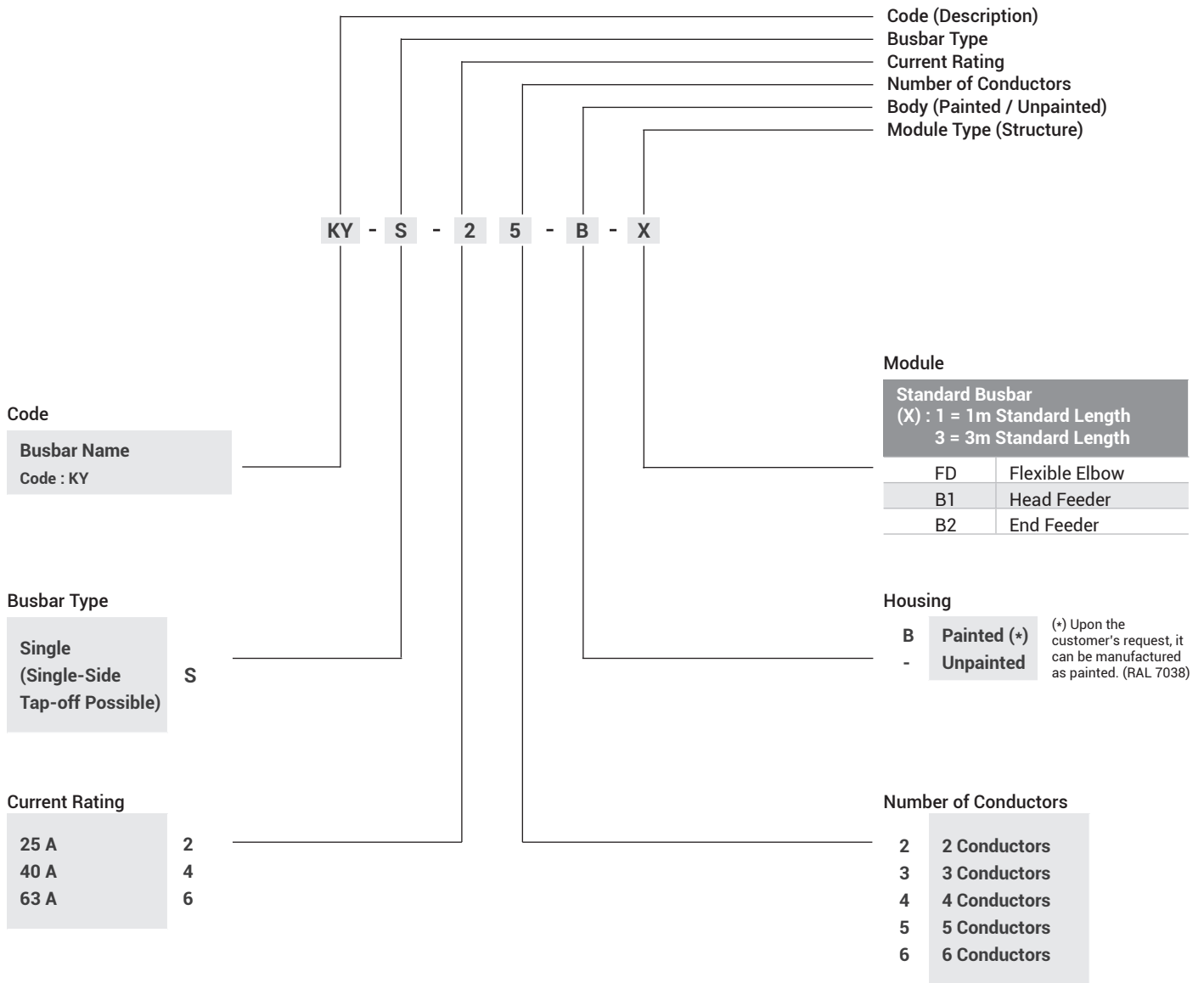

Busbar Function

P	Power
P _{Emg}	Power + Emergency Kit (Emg) Supply
PDL	Power + DALI Lighting Automation
PDL _{Emg}	Power + DALI Lighting Automation + Emergency Kit (Emg) Supply

Protection Conductor

PE	Housing
CPE	Independent Conductor

Addressing Type

P1 - P2 - P3 -P4

Phase Structure

L1	Phase-1
L2	Phase-2
L3/L	Phase-3
N	Neutral
L _{emg}	Emergency Kit (Emg) Phase
N _{emg}	Emergency Kit (Emg) Neutral

Conductor Model

KY-S: C1-C2-C3-C4-C5-C6-C7
KY-S-DALI: C8-C9-C10-C11

DESCRIPTION:

Apart from the information specified as "order code system", the following information is available on the busbar as label information;

- Busbar function,
 - Phase structure,
 - Protection conductor,
 - Conductor model and addressing type
- are available on busbar as label information.

E-LINE KY-S

KY-S Busbar Conductor Structure and Addressing Types



Key Plan

Based on the conductor model given below, determine the KY-S busbar suitable for your needs. For the busbar, tap-off plug, tap-off box and other modules, select the products on the sides of the tables and from the pages given below:

KY-S

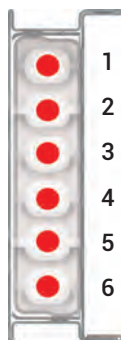

Conductor Model
Addressing Type
Number of Conductors

		L1		L1	L1	L1
		L2		L2	L2	L2
L	L	L3	L	L3	L3	L3
N	N	N	N	N	N	N
	CPE		L _{EMG}	CPE	L _{EMG}	L _{EMG}
			N _{EMG}			N _{EMG}
PE		PE	PE		PE	PE

- See page 7-8 for busbar selection,
- See page 10-13 for plug selection,
- See page 16-20 for box selection.

C1	C2	C3	C4	C5	C6	C7
P1	P2	P1	P1	P2	P1	P1
2	3	4	4	5	5	6

KY-S-DALI

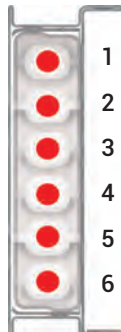

Conductor Model
Addressing Type
Number of Conductors

D1	D1	D1	D1
D2	D2	D2	D2
L	L	L	L1
N	N	N	L2
	L _{EMG}	L _{EMG}	L3
		N _{EMG}	N
PE	PE	PE	PE

- See page 9 for busbar selection
- See page 14-15 for plug selection,

C8	C9	C10	C11
P3	P3	P3	P4
4	5	6	6

- For head feeder (B1) module: See page 21
- For end feeder (B2) module: See page 22
- For flexible elbow (FD) module: See page 23
- For fixing element, installation details and principle connection circuit diagrams, see the following related pages.

■ **Addressing Type:** Operation current plug-in openings and tap-off plugs and boxes are addressed to prevent incorrect use, the tap-off plugs and boxes with different address types and busbars cannot be used with each other.

- **PE** = housing with protective conductor
- **CPE**= Clean protection (clean earth) conductor (Independent conductor)

Conductor Model : C1		2 CONDUCTOR CONSTRUCTION: L-N-PE (housing)				
BUSBAR			ORDER CODE		ADDRESSING TYPE: P1	
Current	Definition (*)	Type	3 m	1 m	Description	
25 A	KY-S 22-3m (1m)	Unpainted	3178721	3178780	It is used with single-phase tap-off plug (L) in lighting, socket and power circuits as single phase distribution. See Table-01 on page 10 for tap-off plugs and See Table-01 on page 16 for tap-off boxes.	
	KY-S 22-B-3m (1m)	Painted	3178735	3178794		
40 A	KY-S 42-3m (1m)	Unpainted	3178725	3178784		
	KY-S 42-B-3m (1m)	Painted	3178740	3178799		
63 A	KY-S 62-3m (1m)	Unpainted	3178730	3178789		
	KY-S 62-B-3m (1m)	Painted	3178745	3178804		

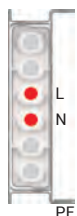

Conductor Model : C2		3 CONDUCTOR CONSTRUCTION : L-N-CPE (clean earth)				
BUSBAR			ORDER CODE		ADDRESSING TYPE: P2	
Current	Definition (*)	Type	3 m	1 m	Description	
25 A	KY-S 23-3m (1m)	Unpainted	3178722	3178781	As a single-phase distribution, it is used with a single-phase tap-off plug (L) in the sockets and power circuits requiring a clean earth conductor. See Table-02 on page 10 for tap-off plugs and See Table-02 on page 16 for tap-off boxes.	
	KY-S 23-B-3m (1m)	Painted	3178736	3178795		
40 A	KY-S 43-3m (1m)	Unpainted	3178726	3178785		
	KY-S 43-B-3m (1m)	Painted	3178741	3178800		
63 A	KY-S 63-3m (1m)	Unpainted	3178731	3178790		
	KY-S 63-B-3m (1m)	Painted	3178746	3178805		



Conductor Model : C3		4 CONDUCTOR CONSTRUCTION : L1-L2-L3-N-PE (housing)				
BUSBAR			ORDER CODE		ADDRESSING TYPE: P1	
Current	Definition (*)	Type	3 m	1 m	Description	
25 A	KY-S 24-3m (1m)	Unpainted	3178723	3178782	As a three-phase distribution, it is used with a single-phase and/or three-phase tap-off plugs in lighting, sockets and power circuits. See Table-03 on page 11 for tap-off plugs and See Table-03 on page 17 for tap-off boxes.	
	KY-S 24-B-3m (1m)	Painted	3178737	3178796		
40 A	KY-S 44-3m (1m)	Unpainted	3178727	3178786		
	KY-S 44-B-3m (1m)	Painted	3178742	3178801		
63 A	KY-S 64-3m (1m)	Unpainted	3178732	3178791		
	KY-S 64-B-3m (1m)	Painted	3178747	3178806		

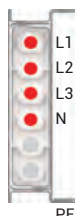

Conductor Model : C4		4 CONDUCTOR CONSTRUCTION : L-N-L _{EMG} -N _{EMG} -PE (housing)				
BUSBAR			ORDER CODE		ADDRESSING TYPE: P1	
Current	Definition (*)	Type	3 m	1 m	Description	
25 A	KY-S 24-EMG-3m (1m)	Unpainted	3182912	3183136	As a single-phase distribution, it is used with single-phase + EMG tap-off plug (L) in lighting fixture circuits with emergency kit. See Table-04 on page 11 for tap-off plugs and See Table-04 on page 17 for tap-off boxes.	
	KY-S 24-EMG-B-3m (1m)	Painted	3183252	3183506		
40 A	KY-S 44-EMG-3m (1m)	Unpainted	3182946	3183170		
	KY-S 44-EMG-B-3m (1m)	Painted	3183291	3183545		
63 A	KY-S 64-EMG-3m (1m)	Unpainted	3182985	3183209		
	KY-S 64-EMG-B-3m (1m)	Painted	3183335	3183589		

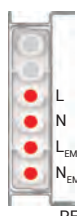

Conductor Model : C5		5 CONDUCTOR CONSTRUCTION : L1-L2-L3-N-CPE (clean earth)				
BUSBAR			ORDER CODE		ADDRESSING TYPE: P2	
Current	Definition (*)	Type	3 m	1 m	Description	
25 A	KY-S 25-3m (1m)	Unpainted	3178724	3178783	As a three-phase distribution, it is used with single-phase and/or three-phase tap-off plugs in the sockets and power circuits requiring a clean earth conductor. See Table-05 on page 12 for tap-off plugs and See Table-05 on page 18 for tap-off boxes.	
	KY-S 25-B-3m (1m)	Painted	3178738	3178797		
40 A	KY-S 45-3m (1m)	Unpainted	3178728	3178787		
	KY-S 45-B-3m (1m)	Painted	3178743	3178802		
63 A	KY-S 65-3m (1m)	Unpainted	3178733	3178792		
	KY-S 65-B-3m (1m)	Painted	3178748	3178807		

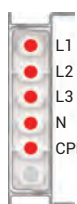

- (*) Marked busbar definitions are given for 3 m standard lengths, take into account the expression in parentheses for 1 m standard lengths.
- In standard manufacturing, the busbar housing is made of pre-galvanized sheet metal. However, it can also be optionally manufactured as painted in RAL 7038 colour.

Conductor Model : C6		5 CONDUCTOR CONSTRUCTION : L1-L2-L3-N-L _{EMG} -PE (housing)			
BUSBAR			ORDER CODE		ADDRESSING TYPE: P1
Current	Definition (*)	Type	3 m	1 m	Description
25 A	KY-S 25-EMG-3m (1m)	Unpainted	3182915	3183139	As a three-phase distribution, it is used with single-phase + EMG tap-off plugs in lighting fixture circuits with emergency kit.
	KY-S 25-EMG-B-3m (1m)	Painted	3183256	3183510	
40 A	KY-S 45-EMG-3m (1m)	Unpainted	3182949	3183173	See Table-06 on page 12 for tap-off plugs and See Table-6/1 ve 6/2 on page 18 for tap-off boxes.
	KY-S 45-EMG-B-3m (1m)	Painted	3183295	3183549	
63 A	KY-S 65-EMG-3m (1m)	Unpainted	3182988	3183212	
	KY-S 65-EMG-B-3m (1m)	Painted	3183339	3183593	

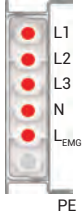

■ Principle Connection Circuit Diagram is given on page-33.

Conductor Model : C7		6 CONDUCTOR CONSTRUCTION : L1-L2-L3-N-L _{EMG} -N _{EMG} -PE (housing)			
BUSBAR			ORDER CODE		ADDRESSING TYPE: P1
Current	Definition (*)	Type	3 m	1 m	Description
25 A	KY-S 26-EMG-3m (1m)	Unpainted	3177338	3182906	As a three-phase distribution, it is used with single-phase + EMG tap-off plugs in lighting fixture circuits with emergency kit.
	KY-S 26-EMG-B-3m (1m)	Painted	3178739	3178798	
40 A	KY-S 46-EMG-3m (1m)	Unpainted	3178729	3178788	See Table-07 on page 13 for tap-off plugs and See Table-7/1 ve 7/2 on page 20 for tap-off boxes.
	KY-S 46-EMG-B-3m (1m)	Painted	3178744	3178803	
63 A	KY-S 66-EMG-3m (1m)	Unpainted	3178734	3178793	
	KY-S 66-EMG-B-3m (1m)	Painted	3178749	3178808	

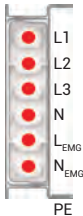

- (*) Marked busbar definitions are given for 3 m standard lengths, take into account the expression in parentheses for 1 m standard lengths.
- In standard manufacturing, the busbar housing is made of pre-galvanized sheet metal. However, it can also be optionally manufactured as painted in RAL 7038 colour.

Conductor Model : C8		4 CONDUCTOR CONSTRUCTION (DALI) : D1-D2-L-N-PE (housing)			
BUSBAR		ORDER CODE		ADDRESSING TYPE: P3	
Current	Definition (*)	Type	3 m	1 m	Description
25 A	KY-S 24-DALI-3m (1m)	Unpainted	3182916	3183140	As a single-phase distribution, it is used with DALI single-phase tap-off plug in luminaire circuits with DALI ballast. See Table-08 on page 14 for tap-off plugs and
	KY-S 24-DALI-B-3m (1m)	Painted	3183257	3183511	
40 A	KY-S 44-DALI-3m (1m)	Unpainted	3182950	3183174	
	KY-S 44-DALI-B-3m (1m)	Painted	3183296	3183550	



■ Principle Connection Circuit Diagram is given on page-36.

Conductor Model : C9		5 CONDUCTOR CONSTRUCTION (DALI) : D1-D2-L-N-L _{EMG} -PE (housing)			
BUSBAR		ORDER CODE		ADDRESSING TYPE: P3	
Current	Definition (*)	Type	3 m	1 m	Description
25 A	KY-S 25-DALI-3m (1m)	Unpainted	3182917	3183141	As a single-phase distribution, it is used with DALI single-phase and DALI single-phase + EMG tap-off plugs in luminaire circuits with DALI ballast and emergency (emg) kits. (Note: The neutral of luminaire and emergency kit is common) See Table-09 on page 14 for tap-off plugs and
	KY-S 25-DALI-B-3m (1m)	Painted	3183258	3183512	
40 A	KY-S 45-DALI-3m (1m)	Unpainted	3182951	3183175	
	KY-S 45-DALI-B-3m (1m)	Painted	3183297	3183551	

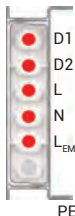

■ Principle Connection Circuit Diagram is given on page-35.

Conductor Model : C10		6 CONDUCTOR CONSTRUCTION (DALI) : D1-D2-L-N-L _{EMG} -N _{EMG} -PE (housing)			
BUSBAR		ORDER CODE		ADDRESSING TYPE: P3	
Current	Definition (*)	Type	3 m	1 m	Description
25 A	KY-S 26-DALI-3m (1m)	Unpainted	3182918	3183142	As a single-phase distribution, it is used with DALI single-phase and DALI single-phase + EMG tap-off plugs in luminaire circuits with DALI ballast and emergency (emg) kits. (Note: The neutral of luminaire and emergency kit is separate) See Table-10 on page 15 for tap-off plugs and
	KY-S 26-DALI-B-3m (1m)	Painted	3183259	3183513	
40 A	KY-S 46-DALI-3m (1m)	Unpainted	3182952	3183176	
	KY-S 46-DALI-B-3m (1m)	Painted	3183298	3183552	

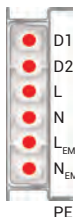

■ Principle Connection Circuit Diagram is given on page-34.

Conductor Model : C11		6 CONDUCTOR CONSTRUCTION (DALI) : D1-D2-L1-L2-L3-N-PE (housing)			
BUSBAR		ORDER CODE		ADDRESSING TYPE: P4	
Current	Definition (*)	Type	3 m	1 m	Description
25 A	KY-S 26-DALI-3m (1m)	Unpainted	3182944	3183168	As a three-phase distribution, it is used with DALI single-phase tap-off plugs in luminaire circuits with DALI ballast. See Table-11 on page 15 for tap-off plugs and
	KY-S 26-DALI-B-3m (1m)	Painted	3183285	3183539	
40 A	KY-S 46-DALI-3m (1m)	Unpainted	3182983	3183207	
	KY-S 46-DALI-B-3m (1m)	Painted	3183329	3183583	

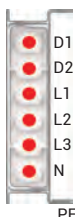

■ Principle Connection Circuit Diagram is given on page-37.

- (*) Marked busbar definitions are given for 3 m standard lengths, take into account the expression in parentheses for 1 m standard lengths.
- KY-S Busbar "DALI" version is not manufactured in 63A. If necessary, please contact our company.
- In standard manufacturing, the busbar housing is made of pre-galvanized sheet metal. However, it can also be optionally manufactured as painted in RAL 7038 colour.

E-LINE KY-S

KY-S Busbar Tap-Off Plug Selection Tables

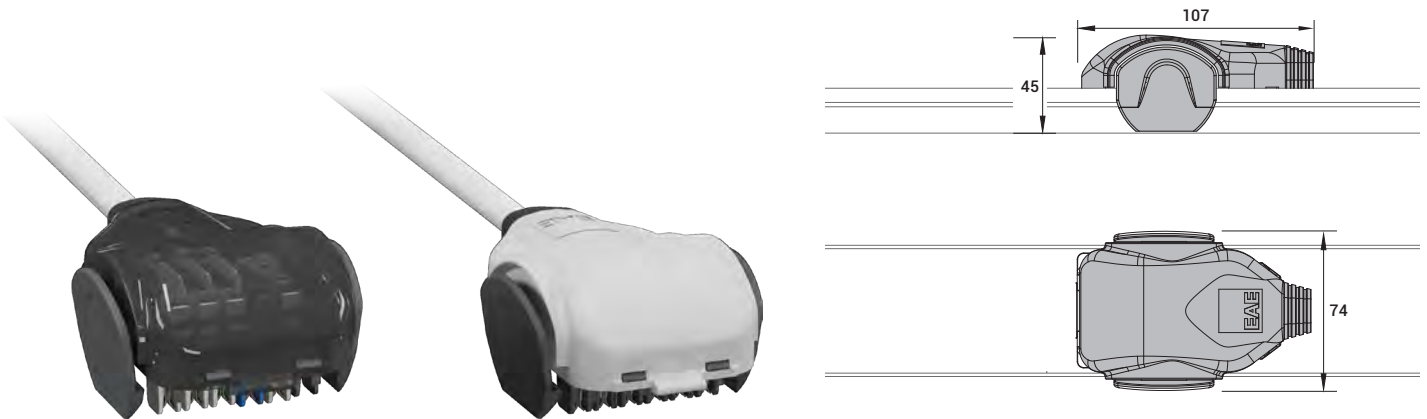

Colour Definitions in Plugs

LOWER HOUSING AND EAR	ADDRESSING TYPE (*)	UPPER HOUSING	PROPERTIES	CABLE GLAND	PHASE/CMD/SIGNAL
GRAY	P1	LIGHT GRAY	SIMPLE AND WITH CLIPS	BROWN	L1 / S1
LIGHT GRAY	P2	TRANSPARENT SMOKY	CARTRIDGE (CYLINDRICAL) FUSE	BLACK	L2 / S2
RED	P3			GRAY	L / L3 / S3
BLACK	P4			ORANGE	L1 / L2 / L3
				YELLOW	DALI

General Descriptions:

- The cross-section of the cable supplied with BL-10 A simple plugs is 0.75mm², its type is 052XZ1-F or H05VV-F, and its length is 75cm.
- The cross-section of the cable supplied with B-16 A simple plugs is 1.5mm², its type is 052XZ1-F or H05VV-F, and its length is 75cm.
- In FS-16 A Cartridge (Cylindrical) fused plugs, the fuse base is 5x20 mm and the cartridge is not included. It can be ordered separately as needed.
- In plugs with K-16 A Terminals, the terminals are suitable for cables with a cross-section of 1.5 - 2.5mm².

CAUTION:

(*) The compatibility of the selected busbar and tap-off plugs is ensured by "addressing pins". If the selected plug does not fit into the busbar current plug-in openings, please do not cut the pins.

KY-S Busbar Tap-Off Plugs : **Table-01**

Power Plug
(Plug)
L/N/PE

Conductor Model	C1
Addressing Type	P1
Number of Conductors	2

KY-S Busbar Tap-Off Plugs : **Table-02**

Power Plug
(Plug)
L/N/CPE

Conductor Model	C2
Addressing Type	P2
Number of Conductors	3

Order Code	TAP-OFF PLUG				
	Description	Current	Cable		
			Cross-Section (mm ²)	Type	Length (m)
3196707	(BL) Simple - HF	10 A	3x0,75	052XZ1-F	0,75
3196538	(BL) Simple - Normal			H05VV-F	
3196718	(B) Simple - HF	16 A	3x1,5	052XZ1-F	
3196546	(B) Simple - Normal			H05VV-F	
3196559	(FS) Cartridge (Cylindrical) Fuse	16 A	Without cable		
3196571	(K) with Clips	16 A	Without cable		

Order Code	TAP-OFF PLUG		Cable		
	Description	Current	Cross Section (mm ²)	Type	Length (m)
--	-				
3196723	(B) Simple - HF	16 A	3x1,5	052XZ1-F	0,75
3196551	(B) Simple - Normal			H05VV-F	
3196564	(FS) Cartridge (Cylindrical) Fuse	16 A	Without cable		
3196576	(K) with Clips	16 A	Without cable		

■ All dimensions are stated in "mm".

KY-S Busbar Tap-Off Plugs : **Table-03**

Power Plugs				L1 L2 L3 N PE	Conductor Model		C3	
(Plug) L1/L2/L3/N/PE	(Plug) L3/N/PE	(Plug) L2/N/PE	(Plug) L1/N/PE		Addressing Type	P1		
Order Code	Order Code	Order Code	Order Code	TAP-OFF PLUG				
				Description	Current	Cable		
						Cross-Section (mm ²)	Type	Length (m)
--	3179155	3179154	3179153	(BL) Simple - HF	10 A	3x0,75	052XZ1-F	0,75
--	3194589	3194588	3194587	(BL) Simple - Normal			H05VV-F	
3196717 (*)	3177342	3177341	3177340	(B) Simple - HF	16 A	3x1,5 (5x1,5)	052XZ1-F	
3196545 (*)	3196716	3196715	3196714	(B) Simple - Normal			H05VV-F	
3196558	3196557	3196556	3196555	(FS) Cartridge(Cylindrical) Fuse	16 A	Without cable		
3179159	3179158	3179157	3179156	(K) With Clips	16 A	Without cable		

Cable cross-sections in parentheses are used in tap-off plugs marked (*).

KY-S Busbar Tap-Off Plugs : **Table-04**

Emergency (Emg.) Kit Supplied Power Plugs (Plug) L/N/L _{EMG} /N _{EMG} /PE		Power Plug (Plug) L/N/PE		L N L _{EMG} N _{EMG} PE	Conductor Model		C4	
Order Code	Order Code	Order Code	Order Code		Addressing Type	P1		
				TAP-OFF PLUG				
				Description	Current	Cable		
						Cross-Section (mm ²)	Type	Length (m)
3207588 (*)	3196707	(BL) Simple - HF	10 A	3x0,75 (5x0,75)	052XZ1-F	0,75		
3207587 (*)	3196538	(BL) Simple - Normal			H05VV-F			
3207598 (*)	3196718	(B) Simple - HF	16 A	3x1,5 (5x1,5)	052XZ1-F			
3207599 (*)	3196546	(B) Simple - Normal			H05VV-F			
3207612	3196559	(FS) Cartridge(Cylindrical) Sig.	16 A	Without cable				
3207617	3196571	(K) With Clips	16 A	Without cable				

Cable cross-sections in parentheses are used in tap-off plugs marked (*).

KY-S Busbar Tap-Off Plugs : **Table-05**

Power Plugs (With Clean Protection Conductor - Clean Earth)			
(Plug) L1/L2/L3/N/CPE	(Plug) L3/N/CPE	(Plug) L2/N/CPE	(Plug) L1/N/CPE
Order Code	Order Code	Order Code	Order Code
--	--	--	--
3196722 (*)	3196721	3196720	3196719
3196550 (*)	3196549	3196548	3196547
3196563	3196562	3196561	3196560
3196575	3196574	3196573	3196572

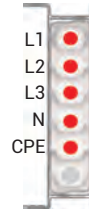

Conductor Model	C5
Addressing Type	P2
Number of Conductors	5

TAP-OFF PLUG				
Description	Current	Cable		
		Cross-Section (mm ²)	Type	Length (m)
(BL) Simple - HF		-		
(BL) Simple - Normal		-		
(B) Simple - HF	16 A	3x1,5 (5x1,5)	052XZ1-F	0,75
(B) Simple - Normal			H05VV-F	
(FS) Cartridge(Cylindrical) Fuse	16 A	Without cable		
(K) With Clips	16 A	Without cable		

Cable cross-sections in parentheses are used in tap-off plugs marked (*).

KY-S Busbar Tap-Off Plugs : **Table-06**

Emergency (Emg.) Kit Supplied Power Plugs (Common Neutral)			Power Plugs		
(Plug) L3/N/L _{EMG} /PE	(Plug) L2/N/L _{EMG} /PE	(Plug) L1/N/L _{EMG} /PE	(Plug) L3/N/PE	(Plug) L2/N/PE	(Plug) L1/N/PE
Order Code	Order Code	Order Code	Order Code	Order Code	Order Code
3207592 (*)	3207591 (*)	3207590 (*)	3179155	3179154	3179153
3207595 (*)	3207594 (*)	3207593 (*)	3194589	3194588	3194587
3207604 (*)	3207603 (*)	3207601 (*)	3177342	3177341	3177340
3207610 (*)	3207608 (*)	3207606 (*)	3196716	3196715	3196714
3207615	3207614	3207613	3196557	3196556	3196555
3207621	3207620	3207618	3179158	3179157	3179156

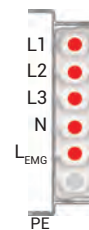

Conductor Model	C6
Addressing Type	P1
Number of Conductors	5

TAP-OFF PLUG				
Description	Current	Cable		
		Cross Section (mm ²)	Type	Length (m)
(BL) Simple - HF	10 A	3x0,75 (4x0,75)	052XZ1-F	0,75
(BL) Simple - Normal			H05VV-F	
(B) Simple - HF	16 A	3x1,5 (4x1,5)	052XZ1-F	
(B) Simple - Normal			H05VV-F	
(FS) Cartridge (Cylindrical) Fuse	16 A	Without cable		
(K) With Clips	16 A	Without cable		

Cable cross-sections in parentheses are used in tap-off plugs marked (*).

E-LINE KY-S

KY-S - DALI Busbar Tap-Off Plug Selection Tables



KY-S Busbar Tap-Off Plugs : **Table-07**

Emergency (Emg.) Kit Supplied Power Plugs			Power Plugs			L1 L2 L3 N L _{EMG} N _{EMG} PE	Conductor Model		C7	
(Plug) L3/N/L _{EMG} /N _{EMG} /PE	(Plug) L2/N/L _{EMG} /N _{EMG} /PE	(Plug) L1/N/L _{EMG} /N _{EMG} /PE	(Plug) L3/N/PE	(Plug) L2/N/PE	(Plug) L1/N/PE		Addressing Type	P1		
Order Code	Order Code	Order Code	Order Code	Order Code	Order Code	TAP-OFF PLUG	Cable			
						Description	Current	Cross Section (mm ²)	Type	Length (m)
3196713 (*)	3196712 (*)	3196711 (*)	3179155	3179154	3179153	(BL) Simple - HF	10 A	3x0,75 (5x0,75)	052XZ1-F	0,75
3196544 (*)	3196543 (*)	3196542 (*)	3194589	3194588	3194587	(BL) Simple - Normal			H05VV-F	
3177345 (*)	3177344 (*)	3177343 (*)	3177342	3177341	3177340	(B) Simple - HF	16 A	3x1,5 (5x1,5)	052XZ1-F	
3196729 (*)	3196728 (*)	3196727 (*)	3196716	3196715	3196714	(B) Simple - Normal			H05VV-F	
3196570	3196569	3196568	3196557	3196556	3196555	(FS) Cartridge(Cylindrical) Sig.	16 A	Without cable		
3196582	3196581	3196580	3179158	3179157	3179156	(K) With Clips	16 A	Without cable		

Cable cross-sections in parentheses are used in tap-off plugs marked (*).

Simple Plug / With Clips Plug (*)/P1

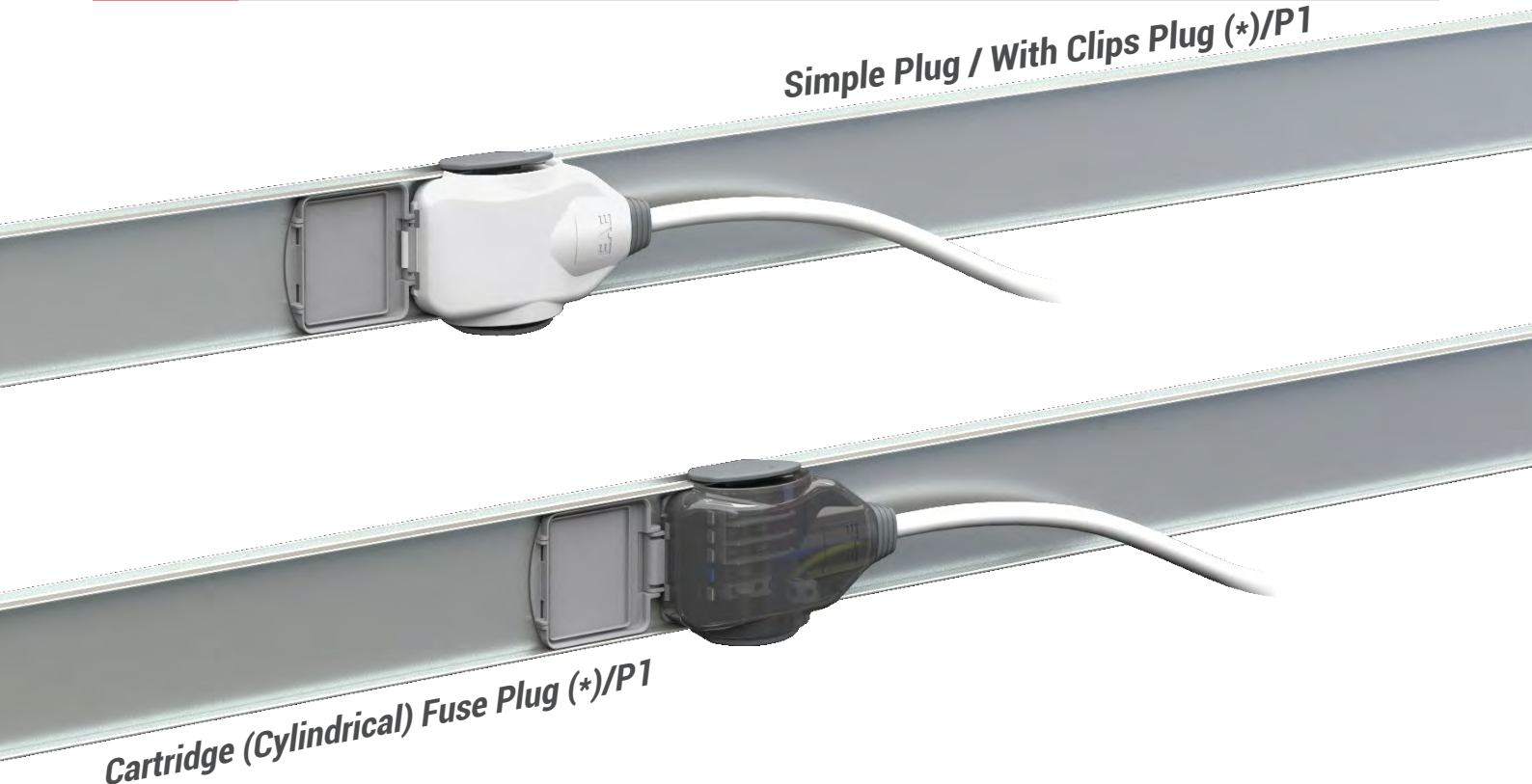

Cartridge (Cylindrical) Fuse Plug (*)/P1

(*) Terminal and Cartridge (Cylindrical) Fused plugs are manufactured as "Without cable".

Colour Definitions in Plugs

LOWER HOUSING AND EAR	ADDRESSING TYPE (*)	UPPER HOUSING	PROPERTIES	CABLE GLAND	PHASE/CMD/SIGNAL
GRAY	P1	LIGHT GRAY	SIMPLE AND WITH CLIPS	BROWN	L1 / S1
LIGHT GRAY	P2	TRANSPARENT SMOKY	CARTRIDGE (CYLINDRICAL) FUSE	BLACK	L2 / S2
RED	P3			GRAY	L / L3 / S3
BLACK	P4			ORANGE	L1 / L2 / L3
				YELLOW	DALI

General Descriptions:

- The cross-section of the cable supplied with BL-10 A simple plugs is 0.75mm², its type is 052XZ1-F or H05VV-F, and its length is 75cm.
- The cross-section of the cable supplied with B-16 A simple plugs is 1.5mm², its type is 052XZ1-F or H05VV-F, and its length is 75cm.
- In FS-16 A Cartridge (Cylindrical) fused plugs, the fuse base is 5x20 mm and the cartridge is not included. It can be ordered separately as needed.
- In plugs with K-16 A Terminals, the terminals are suitable for cables with a cross-section of 1.5 - 2.5mm².

KY-S DALI Busbar Tap-Off Plugs: Table-08

DALI + Power Plug
(Plug)
D1/D2/L/N/PE





Conductor Model	C8
Addressing Type	P3
Number of Conductors	4

TAP-OFF PLUG				
Description	Current	Cable		
		Cross-Section (mm ²)	Type	Length (m)
(BL) Simple - HF	10 A	5x0,75	052XZ1-F	0,75
(BL) Simple - Normal			H05VV-F	
(B) Simple - HF	16 A	5x1,5	052XZ1-F	
(B) Simple - Normal			H05VV-F	
(FS) Cartridge(Cylindrical) Fuse	16 A	Without cable		
(K) With Clips	16 A	Without cable		

Order Code	3196734
Order Code	3196589
Order Code	3196740
Order Code	3196595
Order Code	3196601
Order Code	3196607

KY-S DALI Busbar Tap-Off Plugs: Table-09

DALI +Emergency
(Emg.) Kit Supplied Power
Plugs (Common Neutral)
(Plug)
D1/D2/L/N/L_{EMG}/PE



DALI + Power Plug
(Plug)
D1/D2/L/N/PE





Conductor Model	C9
Addressing Type	P3
Number of Conductors	5

TAP-OFF PLUG				
Description	Current	Cable		
		Cross-Section (mm ²)	Type	Length (m)
(BL) Simple - HF	10 A	5x0,75 (6x0,75)	052XZ1-F	0,75
(BL) Simple - Normal			H05VV-F	
(B) Simple - HF	16 A	5x1,5 (6x1,5)	052XZ1-F	
(B) Simple - Normal			H05VV-F	
(FS) Cartridge(Cylindrical) Fuse	16 A	Without cable		
(K) With Clips	16 A	Without cable		

Order Code	3196736 (*)	Order Code	3196734
Order Code	3196591 (*)	Order Code	3196589
Order Code	3196742 (*)	Order Code	3196740
Order Code	3196597 (*)	Order Code	3196595
Order Code	3196603	Order Code	3196601
Order Code	3196609	Order Code	3196607

Cable cross-sections in parentheses are used in tap-off plugs marked (*).

KY-S DALI Busbar Tap-Off Plugs: **Table-10**

DALI +Emergency (Emg.) Kit Supplied Power Plugs (Plug)
D1/D2/L/N/L_{EMG}/N_{EMG}/PE

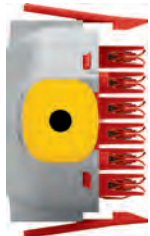

DALI + Power Plug (Plug)
D1/D2/L/N/PE

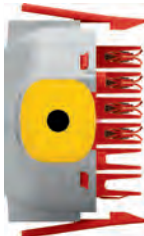

Conductor Model	C10
Addressing Type	P3
Number of Conductors	6

Order Code	Order Code
3196735 (*)	3196734
3196590 (*)	3196589
3196741 (*)	3196740
3196596 (*)	3196595
3196602	3196601
3196608	3196607

TAP-OFF PLUG				
Description	Current	Cable		
		Cross-Section (mm ²)	Type	Length (m)
(BL) Simple - HF	10 A	5x0,75	052XZ1-F	0,75
(BL) Simple - Normal		(7x0,75)	H05VV-F	
(B) Simple - HF	16 A	5x1,5	052XZ1-F	
(B) Simple - Normal		(7x1,5)	H05VV-F	
(FS) Cartridge(Cylindrical) Fuse	16 A	Without cable		
(K) With Clips	16 A	Without cable		

Cable cross-sections in parentheses are used in tap-off plugs marked (*).

KY-S DALI Busbar Tap-Off Plugs: **Table-11**

DALI + Power Plugs

(Plug) D1/D2/L3/N/PE (Plug) D1/D2/L2/N/PE (Plug) D1/D2/L1/N/PE

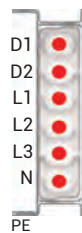
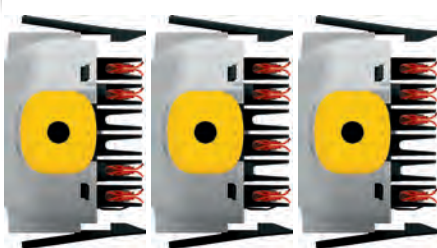

Conductor Model	C11
Addressing Type	P4
Number of Conductors	6

Order Code	Order Code	Order Code
3196739	3196738	3196737
3196594	3196593	3196592
3196745	3196744	3196743
3196600	3196599	3196598
3196606	3196605	3196604
3196612	3196611	3196610

TAP-OFF PLUG				
Description	Current	Cable		
		Cross-Section (mm ²)	Type	Length (m)
(BL) Simple - HF	10 A	5x0,75	052XZ1-F	0,75
(BL) Simple - Normal			H05VV-F	
(B) Simple - HF	16 A	5x1,5	052XZ1-F	
(B) Simple - Normal			H05VV-F	
(FS) Cartridge(Cylindrical) Fuse	16 A	Without cable		
(K) With Clips	16 A	Without cable		

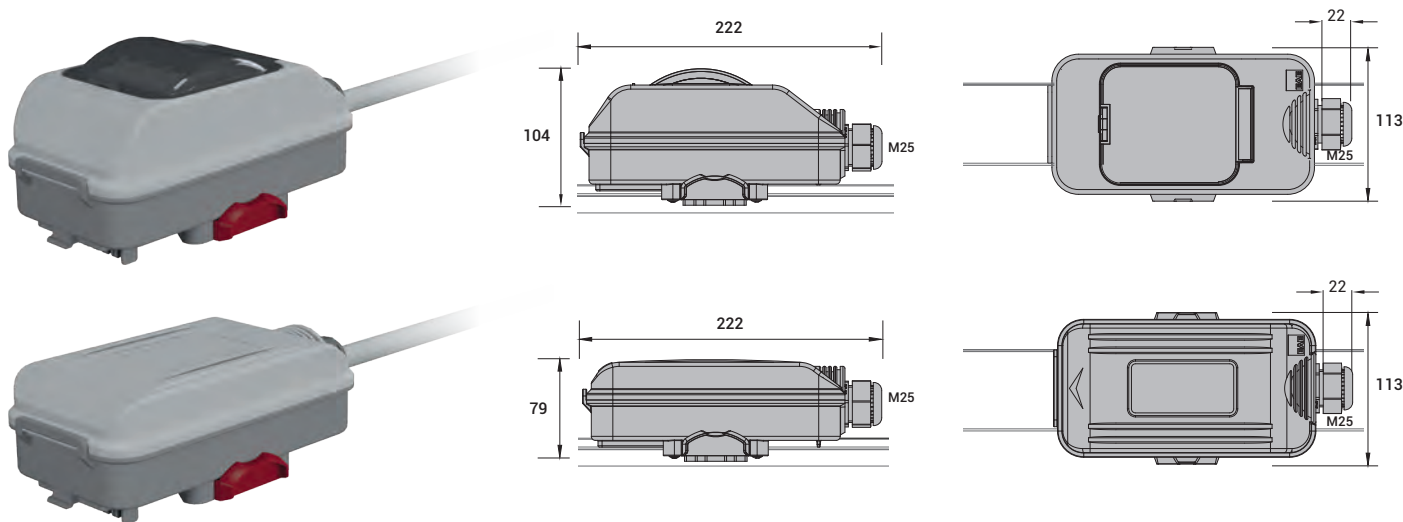

Colour Definitions in Tap-off Boxes

LOWER HOUSING	ADDRESSING TYPE (*)
DARK GRAY	P1
LIGHT GRAY	P2

General Descriptions:

- In FS-32 A Cartridge (cylindrical) fused boxes, the fuse base is 10x38 mm and the cartridge is not included. It should be ordered separately as needed.
- In empty boxes suitable for (MCB)-S empty 32 A MCB, "DIN RAIL" is included, but MCB not included. It should be provided separately as needed.

CAUTION :

(*) The compatibility of the selected busbar and tap-off boxes is ensured by "addressing pins". If the selected box does not fit into the busbar current plug-in openings, please do not cut the pins.

KY-S Busbar Tap-Off Boxes: **Table-01**

Power Tap-off Boxes

(Empty) Power Tap-off Boxes suitable for MCB

Conductor Model	C1
Addressing Type	P1
Number of Conductors	2

Cartridge (Cylindrical) Fuse Power Tap-off Boxes

Cartridge (Cylindrical) Fuse Power Tap-off Boxes

KY-S Busbar Tap-Off Boxes: **Table-02**

Power Tap-off Boxes

(Empty) Power Tap-off Boxes suitable for MCB

Conductor Model	C2
Addressing Type	P2
Number of Conductors	3

Cartridge (Cylindrical) Fuse Power Tap-off Boxes

Cartridge (Cylindrical) Fuse Power Tap-off Boxes

Order Code	TAP-OFF BOXES			
	Current	Cross Section (mm ²)	Terminal (mm ²)	Fuse Base
3196687	(S) Suitable for MCB (Empty)			
	32 A	Without cable	-	DIN RAIL
3196664	(FS) Cartridge (Cylindrical) Fuse			
	32 A	Without cable	2,5-4	10x38mm

Order Code	TAP-OFF BOXES			
	Current	Cross Section (mm ²)	Terminal (mm ²)	Fuse Base
3196692	(S) Suitable for MCB (Empty)			
	32 A	Without cable	-	DIN RAIL
3196669	(FS) Cartridge (Cylindrical) Fuse			
	32 A	Without cable	2,5-4	10x38mm

■ All dimensions are stated in "mm".

KY-S Busbar Tap-Off Boxes: **Table-03**

Power Tap-off Boxes

(Empty) Power Tap-off Boxes suitable for MCB	L1/L2/L3/N/PE	L3/N/PE	L2/N/PE	L1/N/PE
Cartridge (Cylindrical) Fuse Power Tap-off Boxes	L1/L2/L3/N/PE	L3/N/PE	L2/N/PE	L1/N/PE

Order Code

3179160

3196665

Order Code

3196686

3196663

Order Code

3196685

3196662

Order Code

3196684

3196661

Conductor Model	C3
Addressing Type	P1
Number of Conductors	4

TAP-OFF BOXES			
Current	Cross Section (mm ²)	Terminal (mm ²)	Fuse Base
(S) Suitable for MCB (Empty)			
32 A	Without cable	-	DIN RAIL
(FS) Cartridge (Cylindrical) Fuse			
32 A	Without cable	2,5-4	10x38mm

KY-S Busbar Tap-Off Boxes: **Table-04**

Emergency (Emg) Kit Supplied Power Tap-off Boxes

(Empty) Power Tap-off Boxes suitable for MCB	L/N/L _{EMG} /N _{EMG} /PE
Cartridge (Cylindrical) Fuse Power Tap-off Boxes	L/N/L _{EMG} /N _{EMG} /PE

Order Code

3196701

3196678

Order Code

3196697

3196674

Conductor Model	C4
Addressing Type	P1
Number of Conductors	4

TAP-OFF BOXES			
Current	Cross Section (mm ²)	Terminal (mm ²)	Fuse Base
(S) Suitable for MCB (Empty)			
32 A	Without cable	-	DIN RAIL
(FS) Cartridge (Cylindrical) Fuse			
32 A	Without cable	2,5-4	10x38mm

KY-S Busbar Tap-Off Boxes: **Table-05**

Power Tap-off Boxes

(Empty) Power Tap-off Boxes suitable for MCB

Cartridge (Cylindrical) Fuse Power Tap-off Boxes

L1	●
L2	●
L3	●
N	●
CPE	●

Conductor Model	C5
Addressing Type	P2
Number of Conductors	5

TAP-OFF BOXES			
Current	Cross Section (mm ²)	Terminal (mm ²)	Fuse Base
(S) Suitable for MCB (Empty)			
32 A	Without cable	-	DIN RAIL
(FS) Cartridge (Cylindrical) Fuse			
32 A	Without cable	2,5-4	10x38mm

Order Code	Order Code	Order Code	Order Code
3196693	3196691	3196690	3196689
3196670	3196668	3196667	3196666

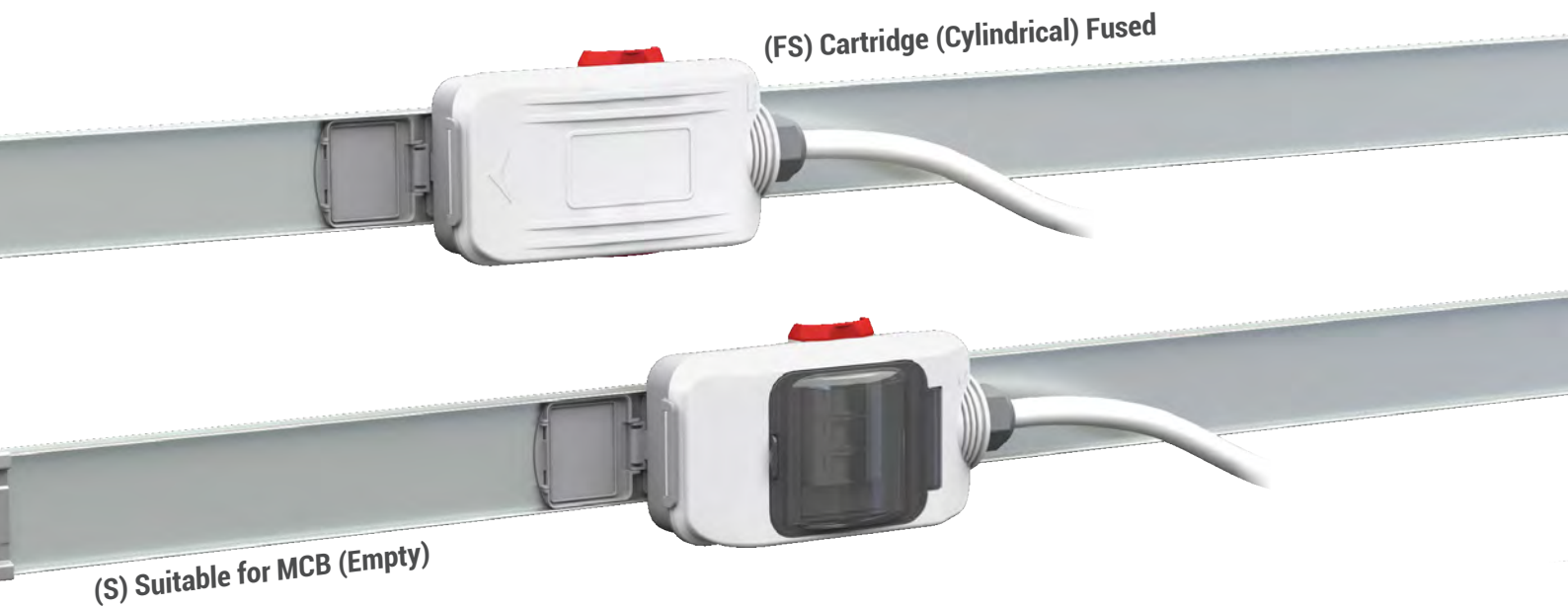

- (*1) In FS-32 A Cartridge (cylindrical) fused boxes, the fuse base is 10x38 mm and the cartridge is not included. It should be ordered separately as needed
- (*2) In empty boxes suitable for (MCB)-S empty 32 A MCB, "DIN RAY" is included, but MCB not included. It should be provided separately as needed.

KY-S Busbar Tap-Off Boxes: **Table-06/1**

Normal ve Emergency (Emg) Kit Supplied Power Tap-off Boxes (Ortak Nötr)

(Empty) Power Tap-off Boxes suitable for MCB

Empty Emergency Kit (Emg) Supplied Power Tap-Off Boxes (Common Neutral) suitable for MCB

L1/L2/L3/N/PE	L3/N/PE	L2/N/PE	L1/N/PE
L1/L2/L3/N/ L _{EMG} /PE	L3/N/L _{EMG} /PE	L2/N/L _{EMG} /PE	L1/N/L _{EMG} /PE

TAP-OFF BOXES			
Current	Cross Section (mm ²)	Fuse Base	
(S) Suitable for MCB (Empty)			
32 A	Without cable	DIN RAIL	

Order Code	Order Code	Order Code	Order Code
3223575	3196696	3196695	3196694
3196706	3196705	3196704	3196703

KY-S Busbar Tap-Off Boxes: **Table-06/2**

Normal and Emergency (Emg) Kit Supplied Power Tap-off Boxes (Common Neutral)

Cartridge (Cylindrical) Fuse Power Tap-off Boxes

Cartridge (Cylindrical) Fused Emergency (Emg) Kit Supplied Power Tap-off Boxes (Common Neutral)

L1/L2/L3/N/PE	L3/N/PE	L2/N/PE	L1/N/PE
L1/L2/L3/N/L _{EMG} /PE	L3/N/L _{EMG} /PE	L2/N/L _{EMG} /PE	L1/N/L _{EMG} /PE

TAP-OFF BOXES		
Current	Cross Section (mm ²)	Fuse Base
(FS) Cartridge (Cylindrical) Fuse		
32 A	Without cable	10x38mm

Order Code	Order Code	Order Code	Order Code
3223576	3196673	3196672	3196671
3196683	3196682	3196681	3196680

KY-S Busbar Tap-Off Boxes: **Table-07/1**

(Empty) Power Tap-off Boxes suitable for MCB

Empty Emergency Kit (Emg) Supplied Power Tap-Off Boxes (Common Neutral) suitable for MCB

Normal and Emergency (Emg) Kit Supplied Power Tap-off Boxes

L1/L2/L3/N/PE	L3/N/PE	L2/N/PE	L1/N/PE
L1/L2/L3/N/L _{EMG} /N _{EMG} /PE	L3/N/L _{EMG} /N _{EMG} /PE	L2/N/L _{EMG} /N _{EMG} /PE	L1/N/L _{EMG} /N _{EMG} /PE

Conductor Model	C7
Addressing Type	P1
Number of Conductors	6

Order Code
3223575
3196702

Order Code
3196696
3196700

Order Code
3196695
3196699

Order Code
3196694
3196698

TAP-OFF BOXES		
Current	Cross Section (mm ²)	Fuse Base
(S) Suitable for MCB (Empty)		
32 A	Without cable	DIN RAIL

KY-S Busbar Tap-Off Boxes: **Table-07/2**

Cartridge (Cylindrical) Fuse Power Tap-off Boxes

Cartridge (Cylindrical) Fused Emergency (Emg) Kit Supplied Power Tap-off Boxes (Common Neutral)

Normal and Emergency (Emg) Kit Supplied Power Tap-off Boxes

L1/L2/L3/N/PE	L3/N/PE	L2/N/PE	L1/N/PE
L1/L2/L3/N/L _{EMG} /N _{EMG} /PE	L3/N/L _{EMG} /N _{EMG} /PE	L2/N/L _{EMG} /N _{EMG} /PE	L1/N/L _{EMG} /N _{EMG} /PE

Conductor Model	C7
Addressing Type	P1
Number of Conductors	6

Order Code
3223576
3196679

Order Code
3196673
3196677

Order Code
3196672
3196676

Order Code
3196671
3196675

TAP-OFF BOXES		
Current	Cross Section (mm ²)	Fuse Base
(FS) Cartridge (Cylindrical) Fuse		
32 A	Without cable	10x38mm

E-LINE KY-S

Head Feeder Module (B1) Selection Table

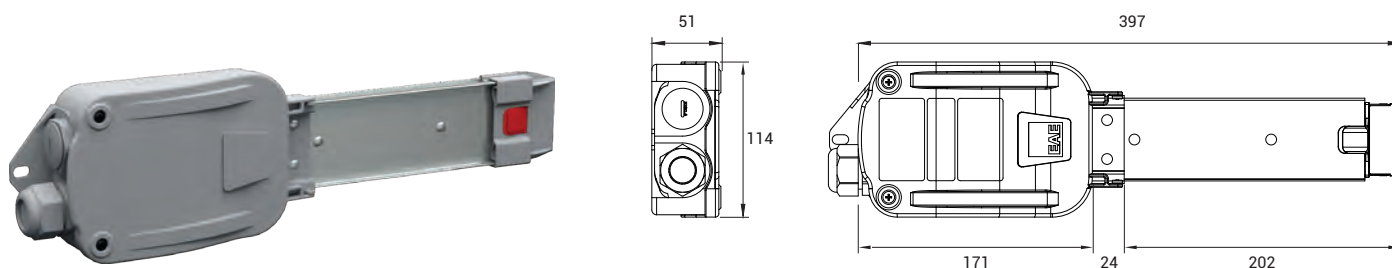

Busbar		Current (A)	Addressing Type	Item No	Conductor Configuration						Unpainted		Painted	
Product Type	Conductor Model				1	2	3	4	5	6	Order Code	Description	Order Code	Description
KY-S Busbar	C1 C3 C4 C6 C7	25	P1	1	L1	L2	L3	N	L _{EMG}	N _{EMG}	3197841	KY-S-26-B1-P1	3197830	KY-S-26-B1-B-P1
	C2 C5		P2	2	L1	L2	L3	N	CPE		3178931	KY-S-25-B1-P2	3197829	KY-S-25-B1-B-P2
KY-S-DALI Busbar	C8 C9 C10		P3	3	D1	D2	L	N	L _{EMG}	N _{EMG}	3197843	KY-S-26-B1-P3	3197832	KY-S-26-B1-B-P3
	C11		P4	4	D1	D2	L1	L2	L3	N	3197844	KY-S-26-B1-P4	3197833	KY-S-26-B1-B-P4
KY-S Busbar	C1 C3 C4 C6 C7	40	P1	1	L1	L2	L3	N	L _{EMG}	N _{EMG}	3197981	KY-S-46-B1-P1	3197971	KY-S-46-B1-B-P1
	C2 C5		P2	2	L1	L2	L3	N	CPE		3178933	KY-S-45-B1-P2	3197970	KY-S-45-B1-B-P2
KY-S-DALI Busbar	C8 C9 C10		P3	3	D1	D2	L	N	L _{EMG}	N _{EMG}	3197984	KY-S-46-B1-P3	3197973	KY-S-46-B1-B-P3
	C11		P4	4	D1	D2	L1	L2	L3	N	3197986	KY-S-46-B1-P4	3197974	KY-S-46-B1-B-P4
KY-S Busbar	C1 C3 C4 C6 C7	63	P1	1	L1	L2	L3	N	L _{EMG}	N _{EMG}	3198022	KY-S-66-B1-P1	3198013	KY-S-66-B1-B-P1
	C2 C5		P2	2	L1	L2	L3	N	CPE		3178935	KY-S-65-B1-P2	3198012	KY-S-65-B1-B-P2

■ KY-S Busbar "DALI" versions is not manufactured in 63A. If necessary, please contact our company.

■ All dimensions are stated in "mm".

E-LINE KY-S

End Feeder Module (B2) Selection Table

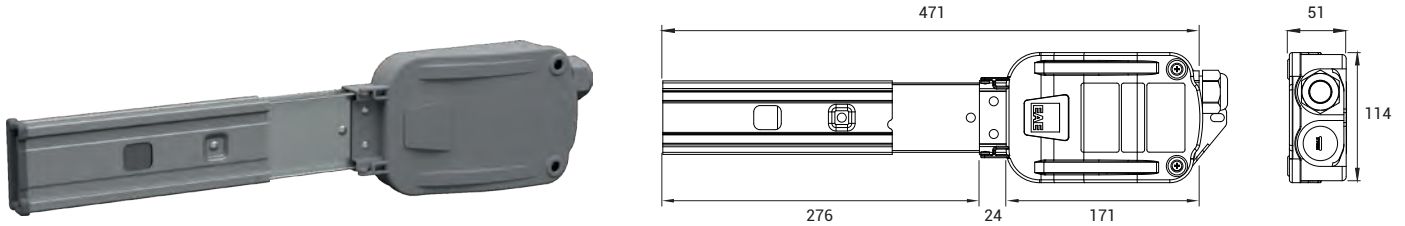

Busbar		Current (A)	Addressing Type	Item No	Conductor Configuration						Unpainted		Painted		
Product Type	Conductor Model				1	2	3	4	5	6	Order Code	Description	Order Code	Description	
KY-S Busbar	C1 C3 C4 C6 C7	25	P1	1	L1	L2	L3	N	L _{EMG}	N _{EMG}	3197866	KY-S-26-B2-P1	3197853	KY-S-26-B2-B-P1	
	C2 C5		P2	2	L1	L2	L3	N	CPE		3178932	KY-S-25-B2-P2	3197852	KY-S-25-B2-B-P2	
KY-S-DALI Busbar	C8 C9 C10		P3	3	D1	D2	L	N	L _{EMG}	N _{EMG}	3197868	KY-S-26-B2-P3	3197855	KY-S-26-B2-B-P3	
	C11		P4	4	D1	D2	L1	L2	L3	N	3197870	KY-S-26-B2-P4	3197856	KY-S-26-B2-B-P4	
KY-S Busbar	C1 C3 C4 C6 C7		40	P1	1	L1	L2	L3	N	L _{EMG}	N _{EMG}	3198003	KY-S-46-B2-P1	3197988	KY-S-46-B2-B-P1
	C2 C5			P2	2	L1	L2	L3	N	CPE		3178934	KY-S-45-B2-P2	3197987	KY-S-45-B2-B-P2
KY-S-DALI Busbar	C8 C9 C10			P3	3	D1	D2	L	N	L _{EMG}	N _{EMG}	3198005	KY-S-46-B2-P3	3197990	KY-S-46-B2-B-P3
	C11			P4	4	D1	D2	L1	L2	L3	N	3198006	KY-S-46-B2-P4	3197991	KY-S-46-B2-B-P4
KY-S Busbar	C1 C3 C4 C6 C7	63		P1	1	L1	L2	L3	N	L _{EMG}	N _{EMG}	3198041	KY-S-66-B2-P1	3198033	KY-S-66-B2-B-P1
	C2 C5			P2	2	L1	L2	L3	N	CPE		3178936	KY-S-65-B2-P2	3198032	KY-S-65-B2-B-P2

■ KY-S Busbar "DALI" versions is not manufactured in 63A. If necessary, please contact our company.

■ All dimensions are stated in "mm".

E-LINE KY-S

Flexible Elbow (FD) Module Selection Table

(*) 63A



(**) 25A - 40A

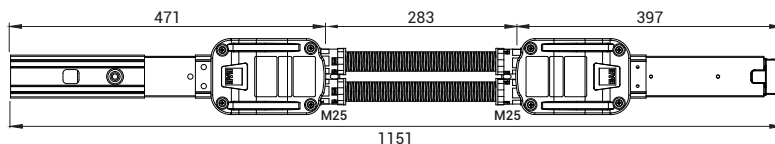

Busbar		Current (A)	Unpainted		Painted	
Product Type	Conductor Model		Order Code	Description	Order Code	Description
KY-S Busbar	C1	25	3179682	KY-S 26-FD	3201403	KY-S 26-B-FD
	C2					
	C3					
	C4					
	C5					
	C6					
	C7					
KY-S-DALI Busbar	C8					
	C9					
	C10					
	C11					
KY-S Busbar	C1	40	3178937	KY-S 46-FD	3201404	KY-S 46-B-FD
	C2					
	C3					
	C4					
	C5					
	C6					
	C7					
KY-S-DALI Busbar	C8					
	C9					
	C10					
	C11					
KY-S Busbar	C1	63	3178938	KY-S 66-FD	3201405	KY-S 66-B-FD
	C2					
	C3					
	C4					
	C5					
	C6					
	C7					

(*) Flexible Elbow for 63A KY-S and KY-S-DALI Busbar.

(**) Flexible Elbow for 25A-40A KY-S and KY-S-DALI Busbar.

E-LINE KY-S

Busbar and Fitting Brackets

U Hanger (KY-S)



Luminaire Hanger

Description	Order Code
U Hanger - Unpainted (KY-S)	3141733
U Hanger - Painted (KY-S)	3241417

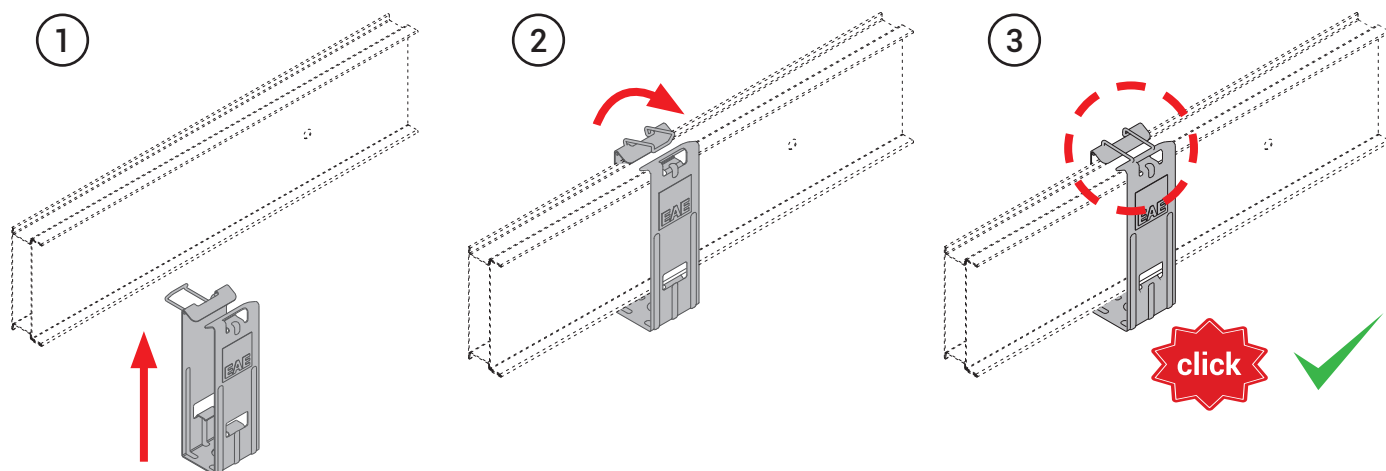
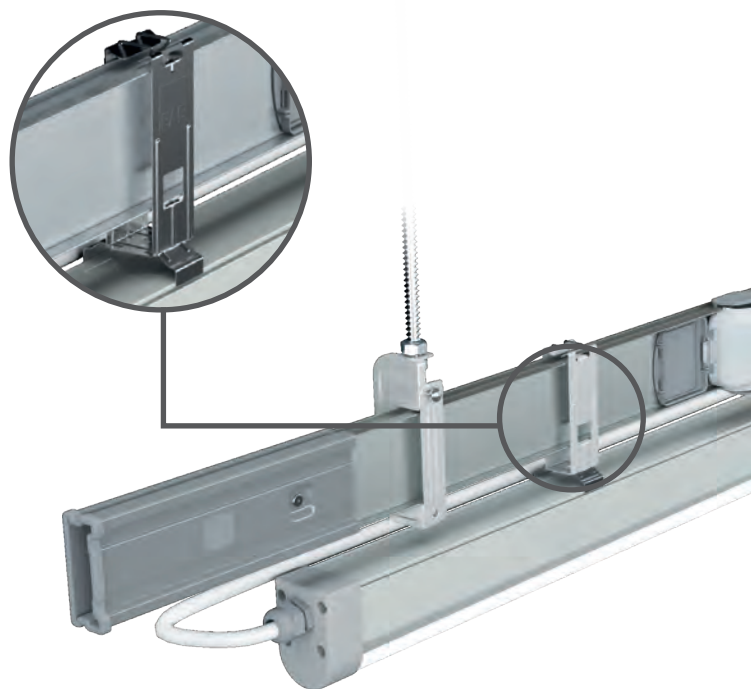
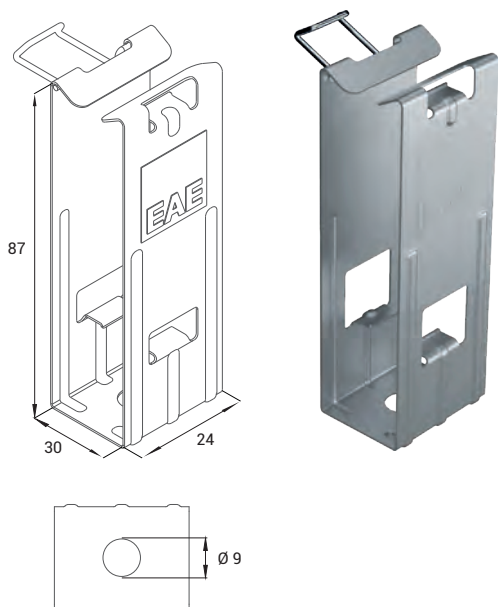

■ All dimensions are stated in "mm".

E-LINE KY-S

Busbar and Fitting Brackets

Universal Fitting Bracket (KY-S)



Busbar Hanger

Description	Order Code
Universal Fitting Bracket (KY-S)- Unpainted	3177557
Universal Fitting Bracket (KY-S)- Painted	3241418

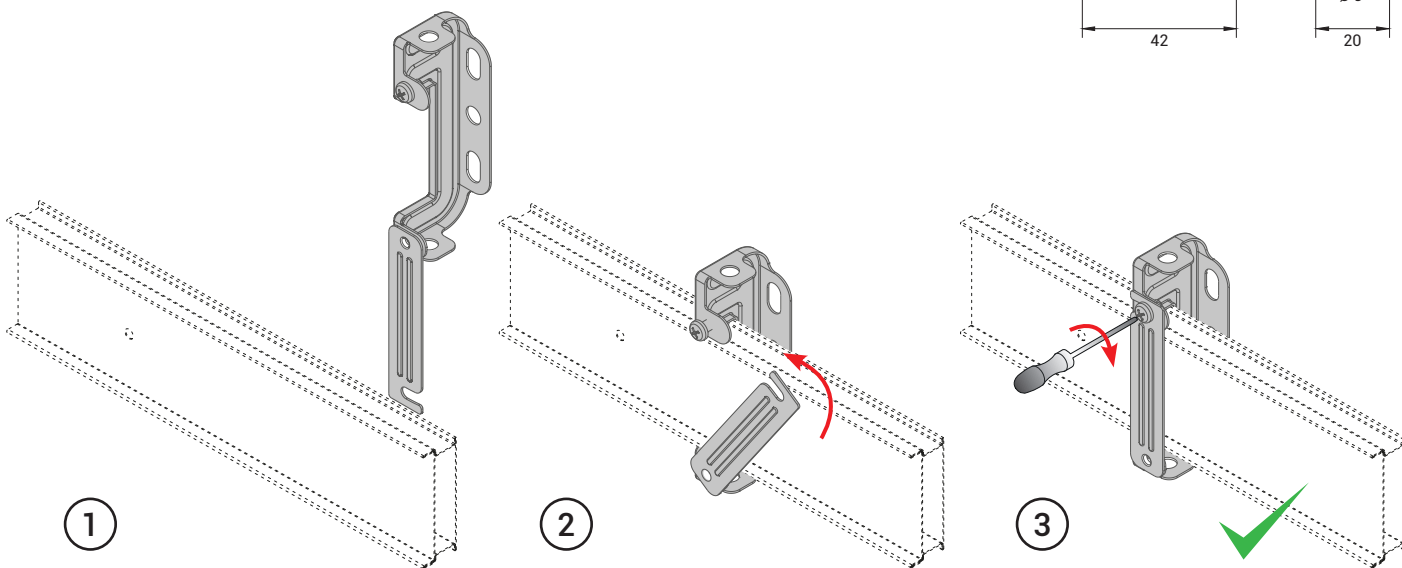
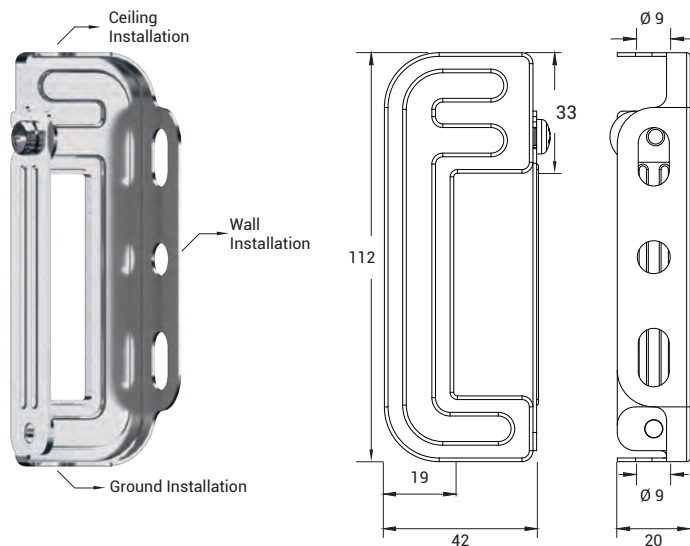

CAUTION : In long KY-S busbar lines, rigid hangers should be used at maximum every 25 meters to prevent lateral vibration and oscillation.



CAUTION: The installation of the line must never be carried out with the windows facing downward.

■ All dimensions are stated in "mm".

E-LINE KY-S

Busbar and Fitting Brackets

Multifunctional Hanger (KY-S)



Description	Order Code
Multifunctional Bracket (KY-S)- Unpainted	3241413
Multifunctional Bracket (KY-S)- Painted	3241419

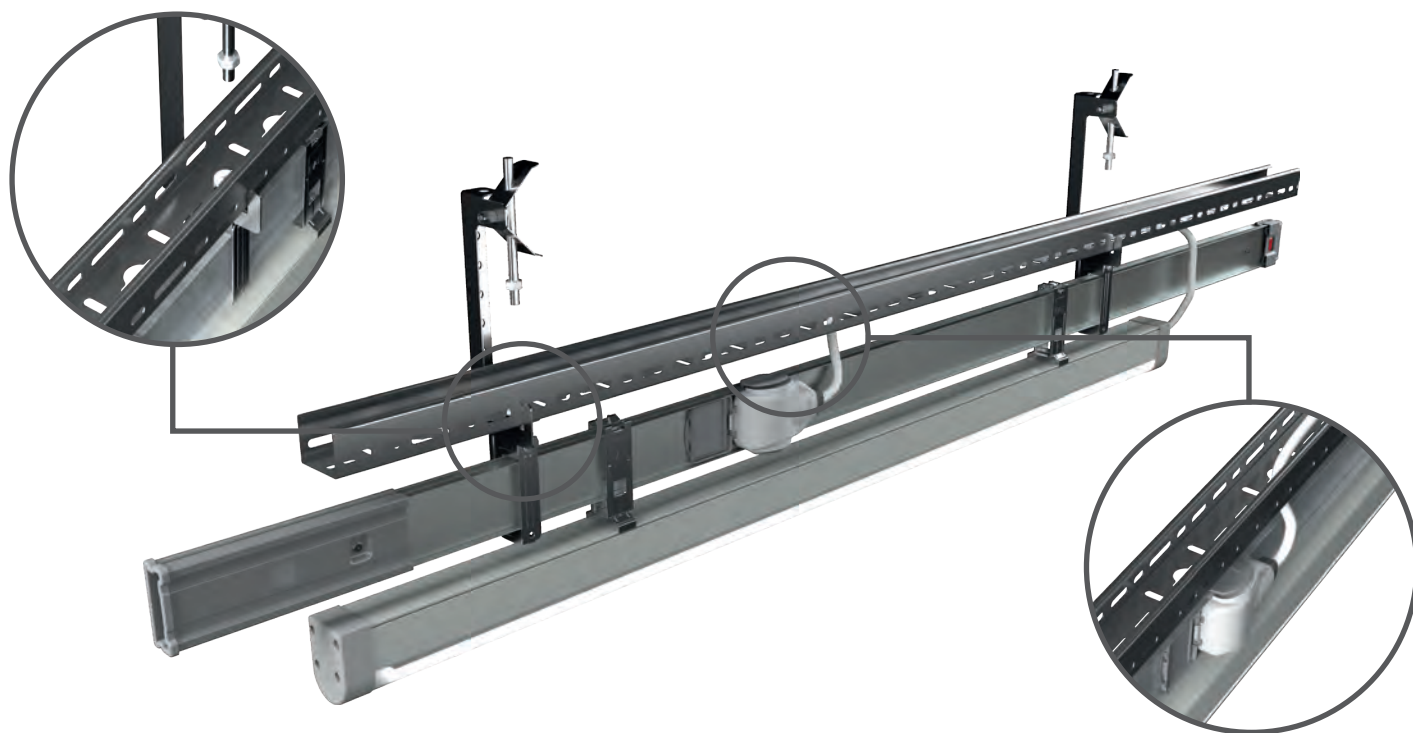
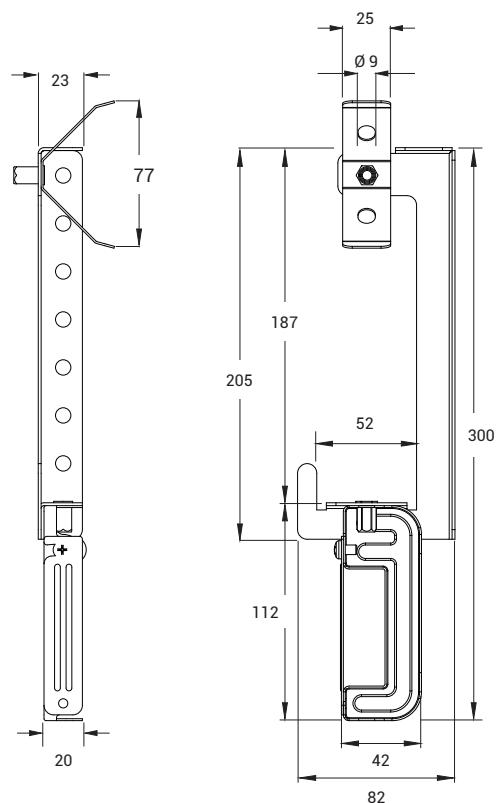
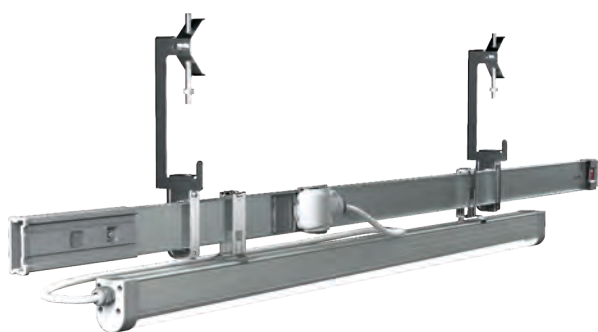

■ All dimensions are stated in "mm".

E-LINE KY-S

Accessories



Integrated Cartridge Fused Tap-Off Plug with Schuko Socket Adapter (240V, L/N/PE, 1x16A Socket Included)

Description	Order Code
KY 16A-FS Power Plug - L1- P1	3247085
KY 16A-FS Power Plug - L2- P1	3247086
KY 16A-FS Power Plug - L3- P1	3247088

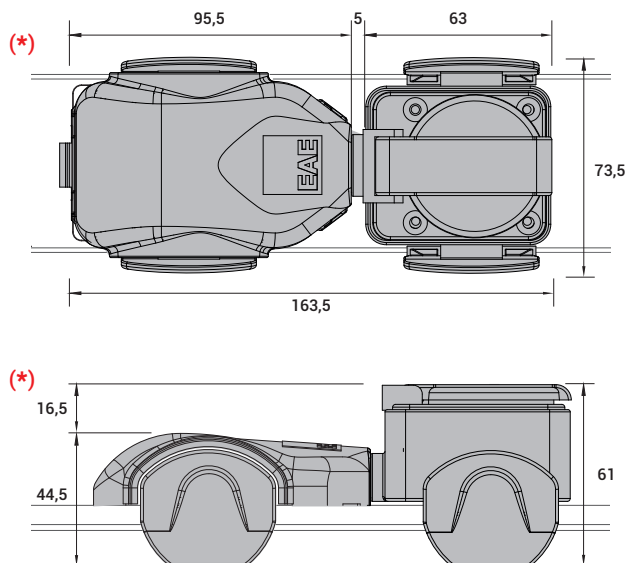

(*) With Tap-Off Plug: 20x5mm and 15A cylindrical fuse cartridges are included.

Schuko Socket Adapter (Including Socket)

Description	Order Code
KY- Schuko Socket Adapter	2111756

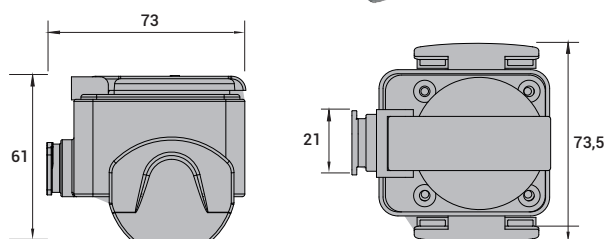

■ Tap-Off Plug is not included in the adapter and should be ordered separately if needed.



KY-S Cable Clip

Description	ORDER CODE
KY-S Cable Clip	1037888

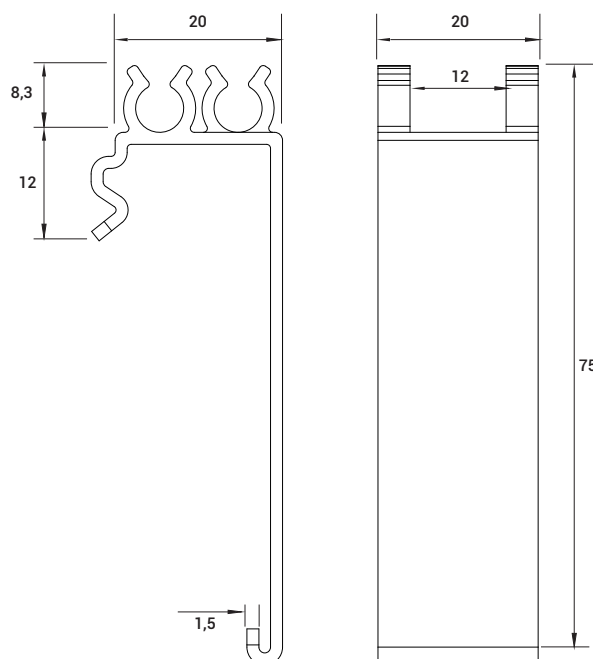
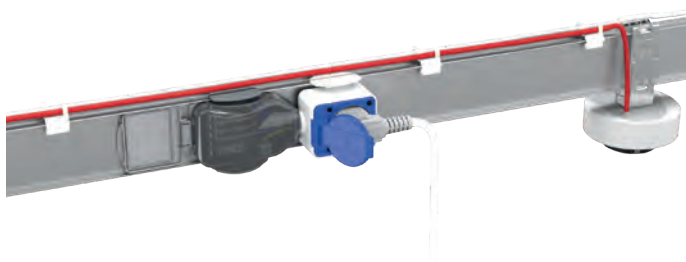

■ All dimensions are stated in "mm".

E-LINE KY-S

Protection and End Closer Covers



Note: Be sure to use the end closer plastics during installation.

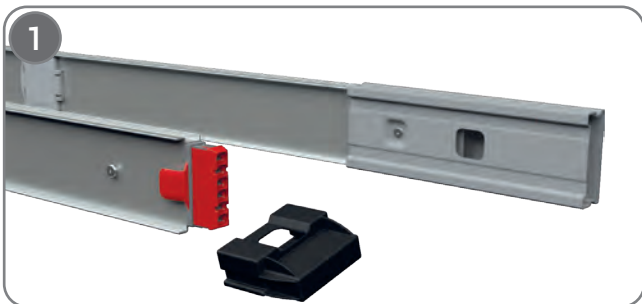

The **protection** plastics is in "black" colour and is supplied on the busbar. It will be discarded before assembly.

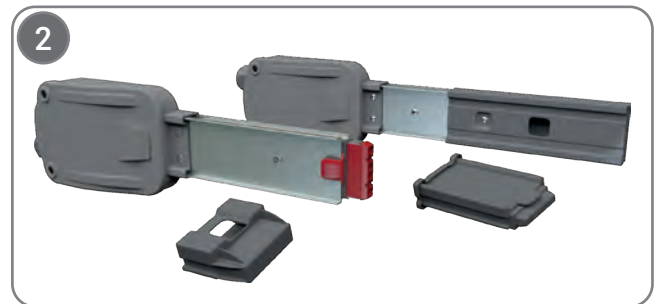

The **end closer** plastics are in "gray" and are supplied on the feeders. It will be disassembled before installation and used as an end closer.

Installing Busbar Joint

Note: There is no need for any other operation such as bolt tightening and hand tools.

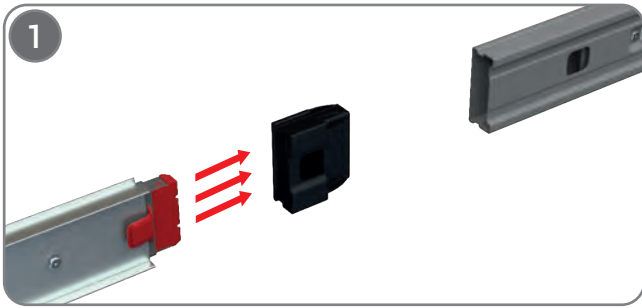

Remove and discard the protection plastics on the busbars.

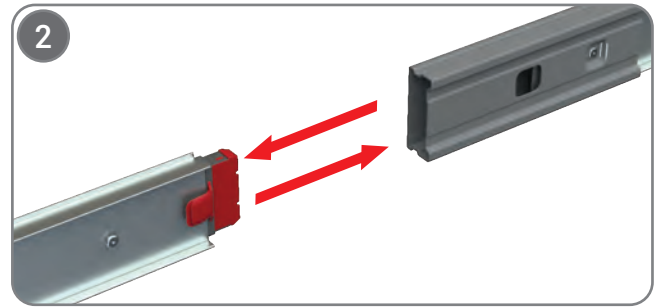

Slide one end of the busbar into the joint module on the other side.

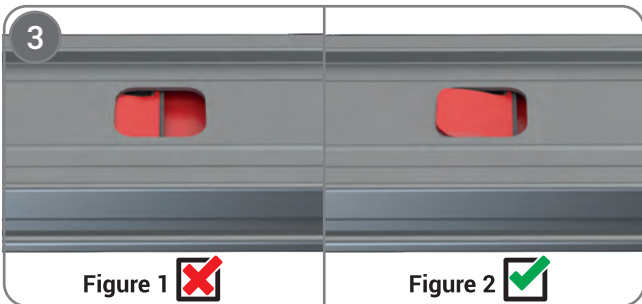

Quickly push the two busbars so that they are clamped as in Figure 2.

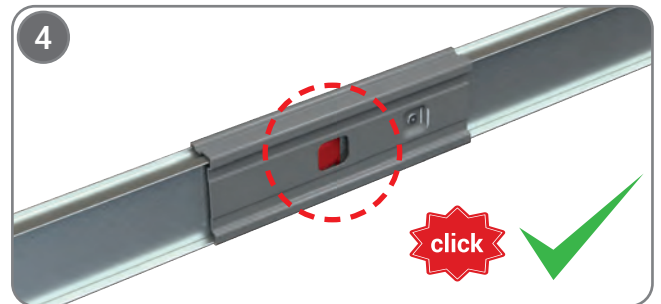

Make sure you hear the clicking sound for correct connection.

Simple Tap-Off Plug Installation

Note: Simple plugs are supplied with the cable attached, ready to use.

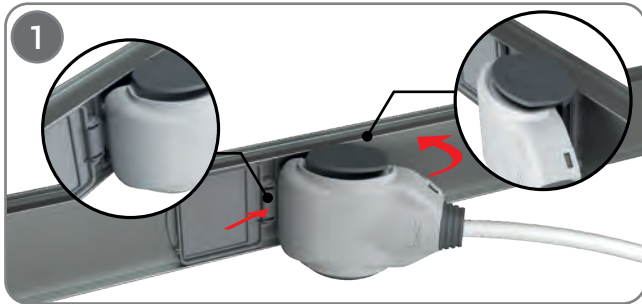

Open the closed plug-in opening cover on the busbar. The tap off plug should be installed in the direction as stated in the figure. Tabs which located on the edge of the tap off plug must be installed to the current output windows which located on busbar itself with an angular position. Tap off plug should be positioned parallel to the busbar.

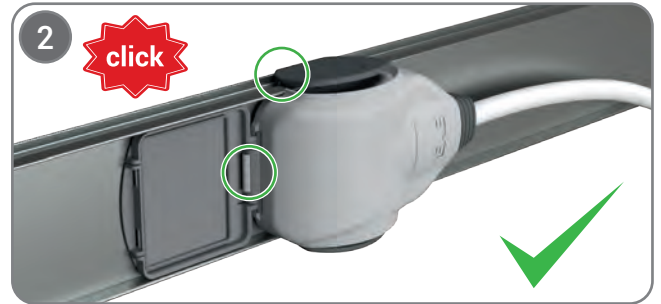

Spring type parts located on the edges of the tap off plug should be installed by pressing to the busbar by making sure of its totally merged.

(Caution: Make sure fixing the plug to the busbar properly.)

E-LINE KY-S

Tap-off Plugs with clips/Cylindrical Fuse Installation

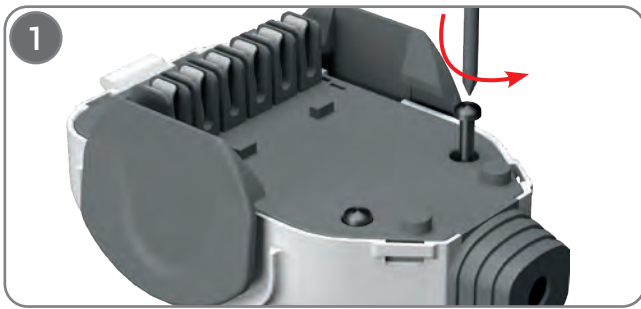

Turn the plug to be used upside down and remove two screws at bottom.

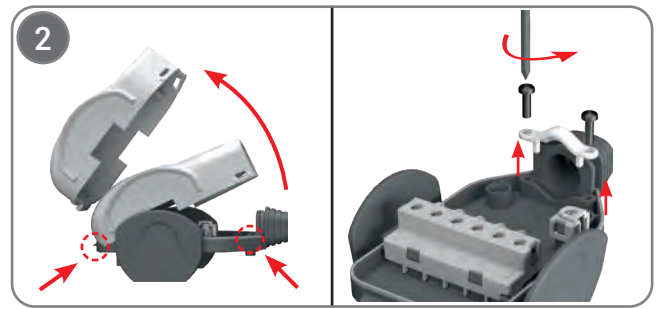

Remove the plug cover as shown in the figure. Remove the cable clamp by unscrewing the two screws.

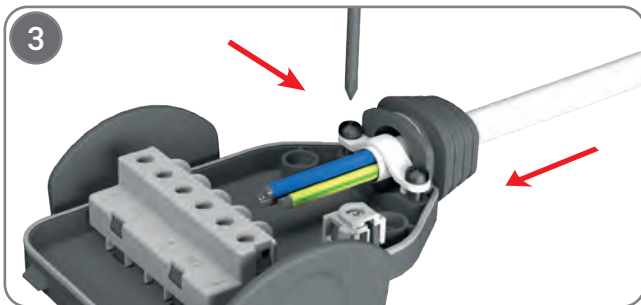

Pass the cable through the cable gland that provides IP protection to the plug and tighten both screws sufficiently by seating the cable clamp into place.

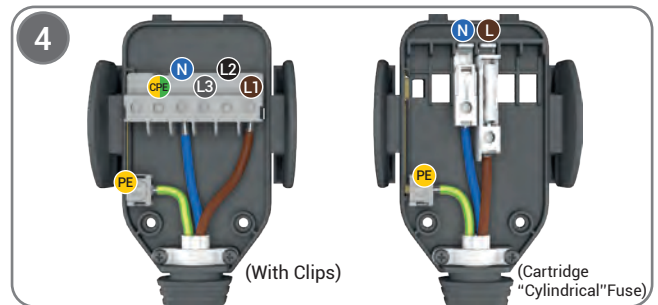

Please connect the yellow/green protective conductor to the earthing (PE) terminal, the blue neutral conductor cable to the neutral (N) terminal, and the other phase cable(s) to the relevant phase (L1, L2, L3) terminals. **(Caution: Make sure that the terminal screws are tightened enough.)**

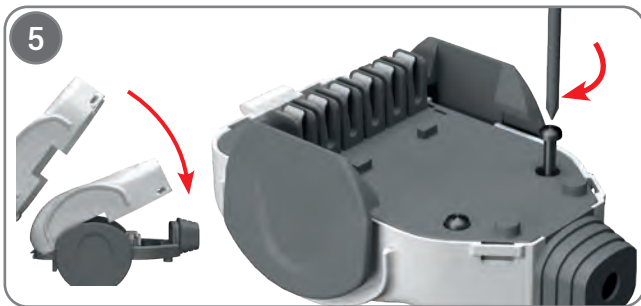

Replace the plug cover, turn the plug upside down and replace the two screws on the back.

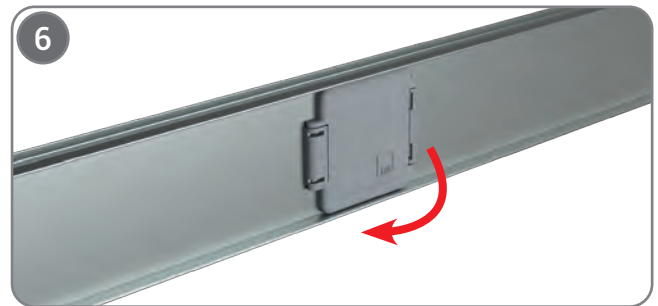

Open the closed plug-in opening cover on the busbar.

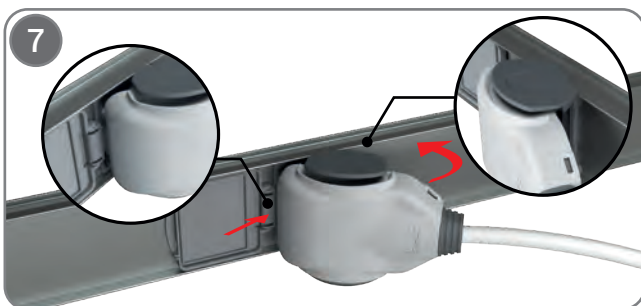

The tap off plug should be installed in the direction as stated in the figure. Tabs which located on the edge of the tap off plug must be installed to the current output windows which located on busbar itself with an angular position. Tap off plug should be positioned parallel to the busbar.

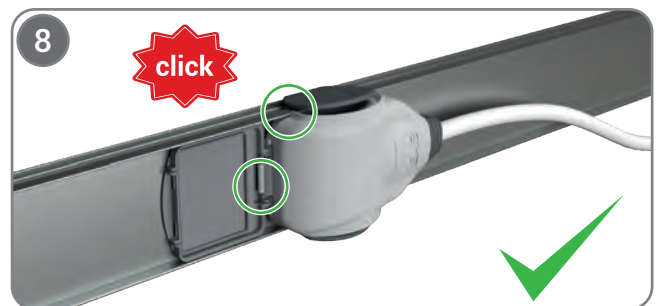

Spring type parts located on the edges of the tap off plug should be installed by pressing to the busbar by making sure of its totally merged.

(Caution: Make sure fixing the plug to the busbar properly.)

E-LINE KY-S

Miniature Circuit Breaker (MCB) Tap-Off Box Installation



Note: Miniature circuit breaker (MCB) is not included in the product and is supplied as an empty DIN rail box. MCB must be ordered separately.

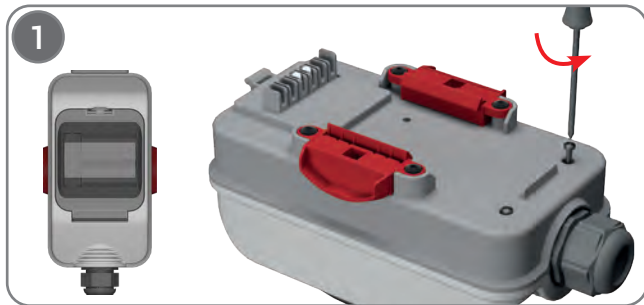

Turn the box to be used upside down and remove two screws at bottom.

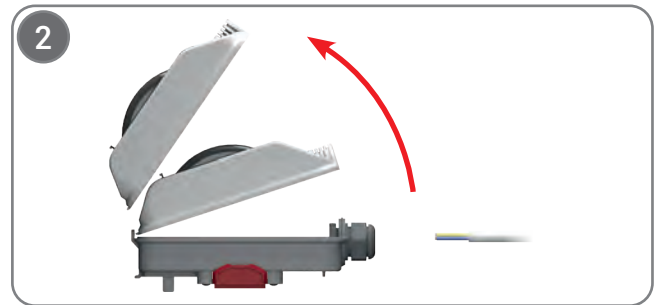

Open the cover of the box as shown in the figure and take it out.

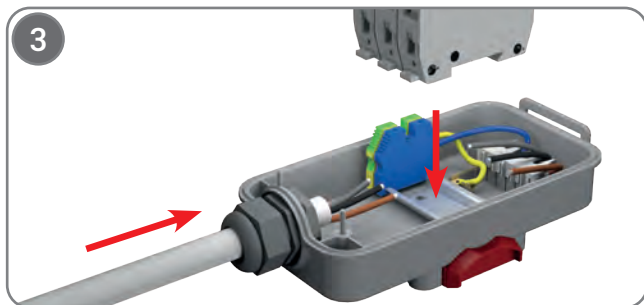

Pass the cable through the cable gland that provides IP protection to the box. Install the miniature circuit breaker (MCB) not exceeding the maximum 32A on the existing DIN rail in the box. (MCB should be in the "off" position.)

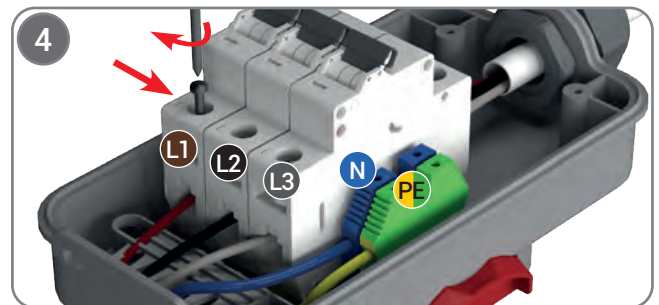

Please connect the yellow protective conductor to the earthing (PE) terminal, the blue neutral conductor cable to the neutral (N) terminal, and the other cables to the relevant phase (L1, L2, L3) terminals. Connect the existing cable ends from the contacts to the input terminals of the MCB in the same way. Complete the operation by tightening the cable gland sufficiently. **(Caution:** Make sure that the terminal screws are tightened enough.)

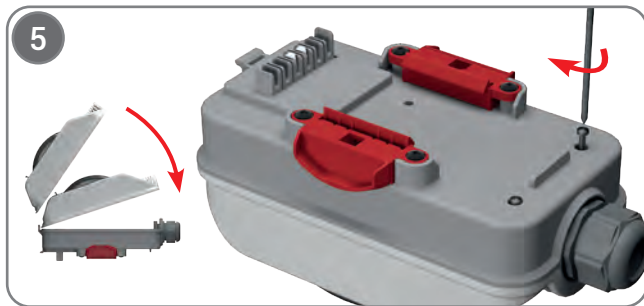

Replace the plug cover, turn the plug upside down and replace the two screws on the back.

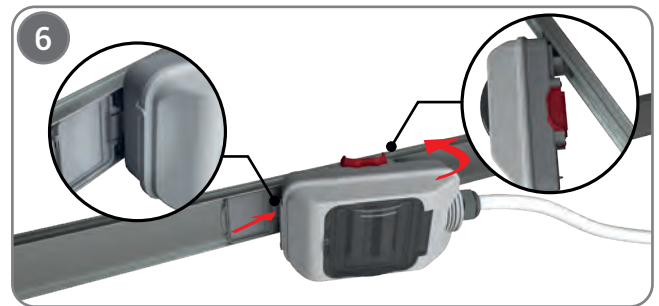

Open the closed plug-in opening on the busbar. The insertion direction of the box should be as shown in the figure. Tabs which located on the edge of the tap off box must be installed to the current output windows which located on busbar itself with an angular position. Tap off box should be positioned parallel to the busbar.



Spring type parts which located on the edges of the tap off box should be installed by pressing to the busbar by making sure of its totally merged. **(Caution:** Make sure fixing the tap off box to the busbar properly.)



Switch miniature circuit breaker (MCB) to "ON" position and close the transparent cover.

E-LINE KY-S

Tap-Off Box with Cartridge (Cylindrical) Fuse Installation



Note: In boxes with cartridge (cylindrical) fuses, a 10x30mm fuse base is included in the product, but the fuse cartridge is not included. The cylindrical fuse cartridge must be ordered separately.

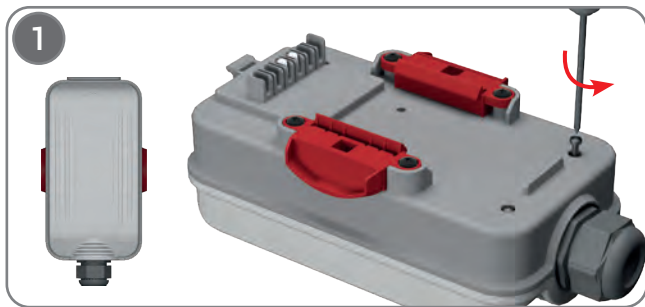

Turn the box to be used upside down and remove two screws at bottom.

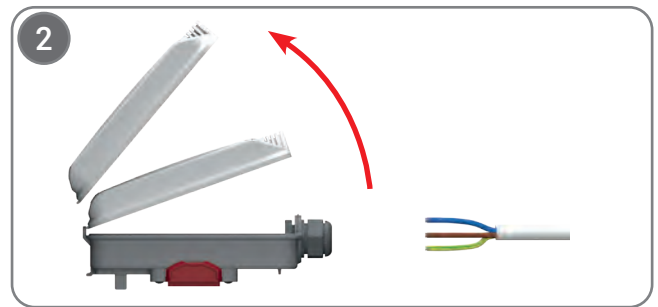

Open the cover of the box as shown in the figure and take it out.

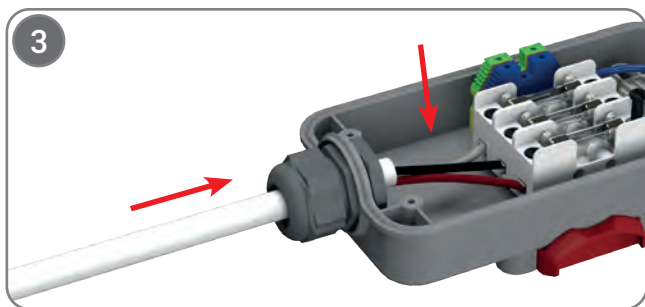

Pass the cable through the cable gland that provides IP protection to the box. Install cartridge (cylindrical) fuses up to a maximum of 32A on 10x38 mm bases.

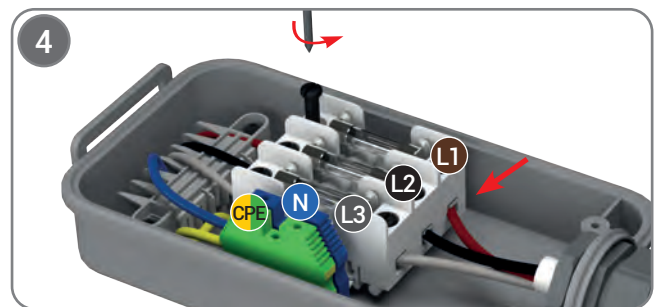

Please connect the yellow protective conductor to the earthing (PE) terminal, the blue neutral conductor cable to the neutral (N) terminal, and the other cables to the relevant phase (L1, L2, L3) terminals. Complete the operation by tightening the cable gland sufficiently. **(Caution:** Make sure that the terminal screws are tightened enough.)

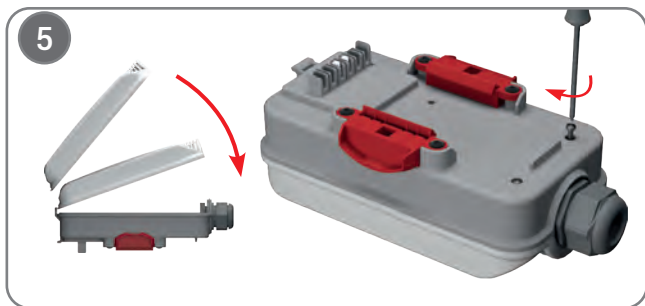

Replace the box cover, turn the box upside down and replace the two screws on the back.

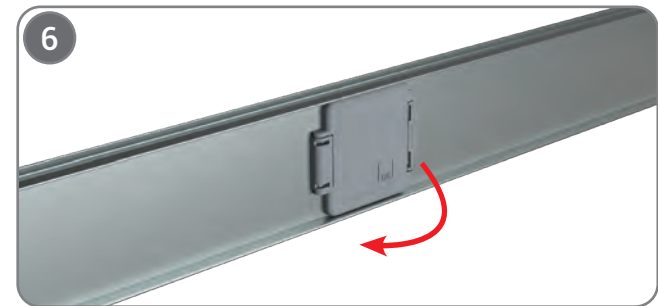

Open the closed plug-in opening cover on the busbar.

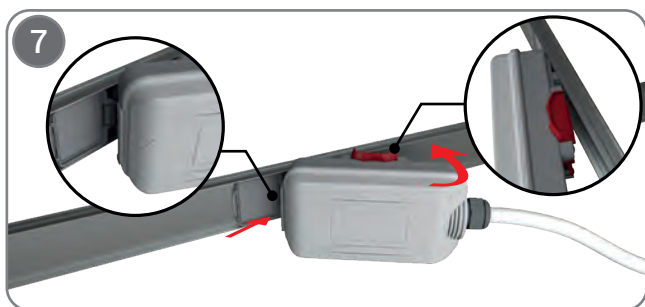

The tap off box should be installed in the direction as stated in the figure. Tabs which located on the edge of the tap off box must be installed to the current output windows which located on busbar itself with an angular position. Tap off box should be positioned parallel to the busbar.



Spring type parts which located on the edges of the tap off box should be installed by pressing to the busbar by making sure of its totally merged. **(Caution:** Make sure fixing the tap off box to the busbar properly.)



Maintenance-Free

Keeping the product clean is sufficient for long-term use..



Plug-in / Plug & Play

The luminaire can be connected and disconnected via the outlet plug while energized.



Easy Suspension

Can be easily installed with a wide range of suspension accessories.



Flame Retardant

Its metal housing does not propagate fire. With its halogen-free structure, it does not emit toxic gases.



Fast Installation Feature

Up to 4 times faster and easier compared to cable trunking systems.



Modular Design

Allows disassembly and repeated reuse.



Provides Flexibility

Power outlets can be taken at every 1 meter.



Long Service Life

Used for many years thanks to its durable metal housing and contact structures.

E-LINE KY-S

KY-S Busbar (5 Conductors/L1-L2-L3-N-L_{EMG}-Pe_{Housing}) Principle Connection Circuit Diagram (Common Neutral) With Residual Current Device (RCD)



CAUTION : If there is a Residual Current Device (RCD) in the circuit !..

IMPORTANT NOTES :

- (*1): When using the common neutral busbar, if a residual current device (RCD) is to be used in the circuit, each line miniature circuit breakers (MCB) should be installed after the RCD as seen in the figure.
- (*2): The emergency kit reference voltage (LEMV) must not be switched.
- (*3): For "MCB" and "RCD" types and current-voltage values, the selection criteria defined in IEC 60364-4-43 should be taken as basis.
- (*4): The cable cross-sections are given as examples. The selection criteria defined in IEC 60364 should be taken as basis.
- (*5): In the circuits in which a Residual Current Device (RCD) is used, for luminaires with Emergency kit, the kit and the fixture supply must be in the same phase.

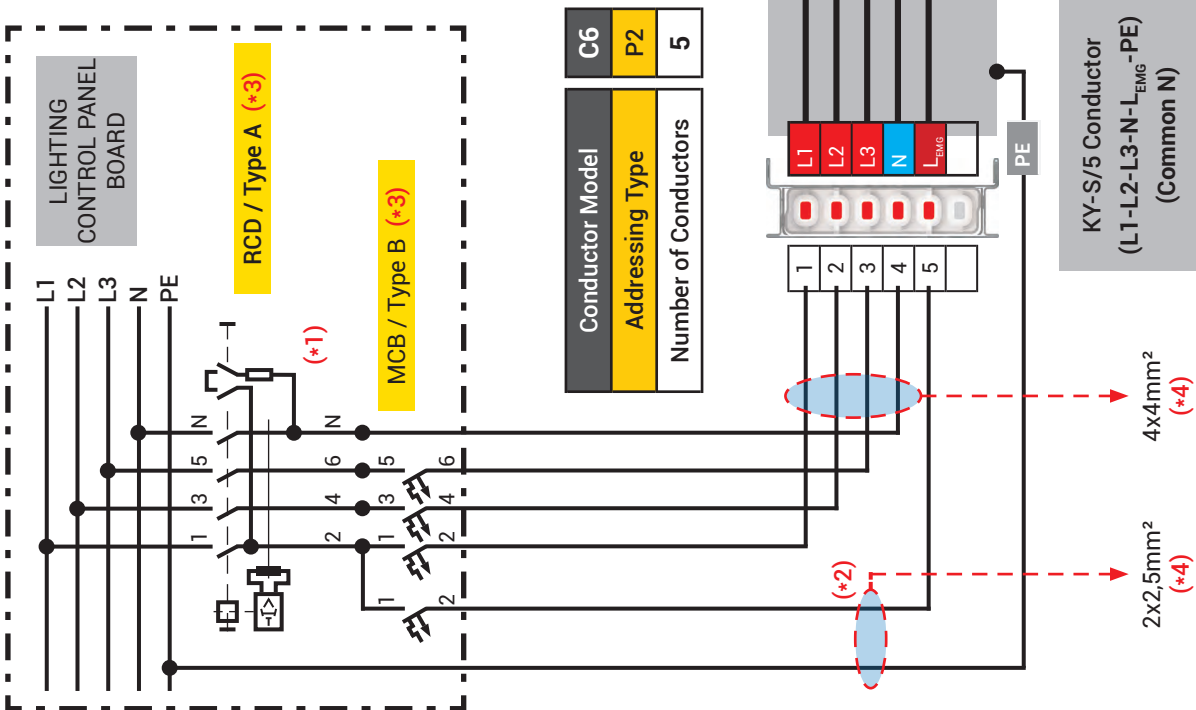

Conductor Model	C6
Addressing Type	P2
Number of Conductors	5

Power Plug (L1-N-PE)
Power Plug (L2-N-PE)
Power Plug (L3-N-PE)

Power Plug (L1-N-L _{EMG} -PE)
Power Plug (L2-N-L _{EMG} -PE)
Power Plug (L3-N-L _{EMG} -PE)

Power + EMG Branch BOX (L1-L2-L3-N-L _{EMG} -PE)
--



E-LINE KY-S

KY-S-DALI Busbar (6 Conductors/D1-D2-L-N-L_{emg}-N_{emg}-Pe_{Housing}) Principle Connection Circuit Diagram

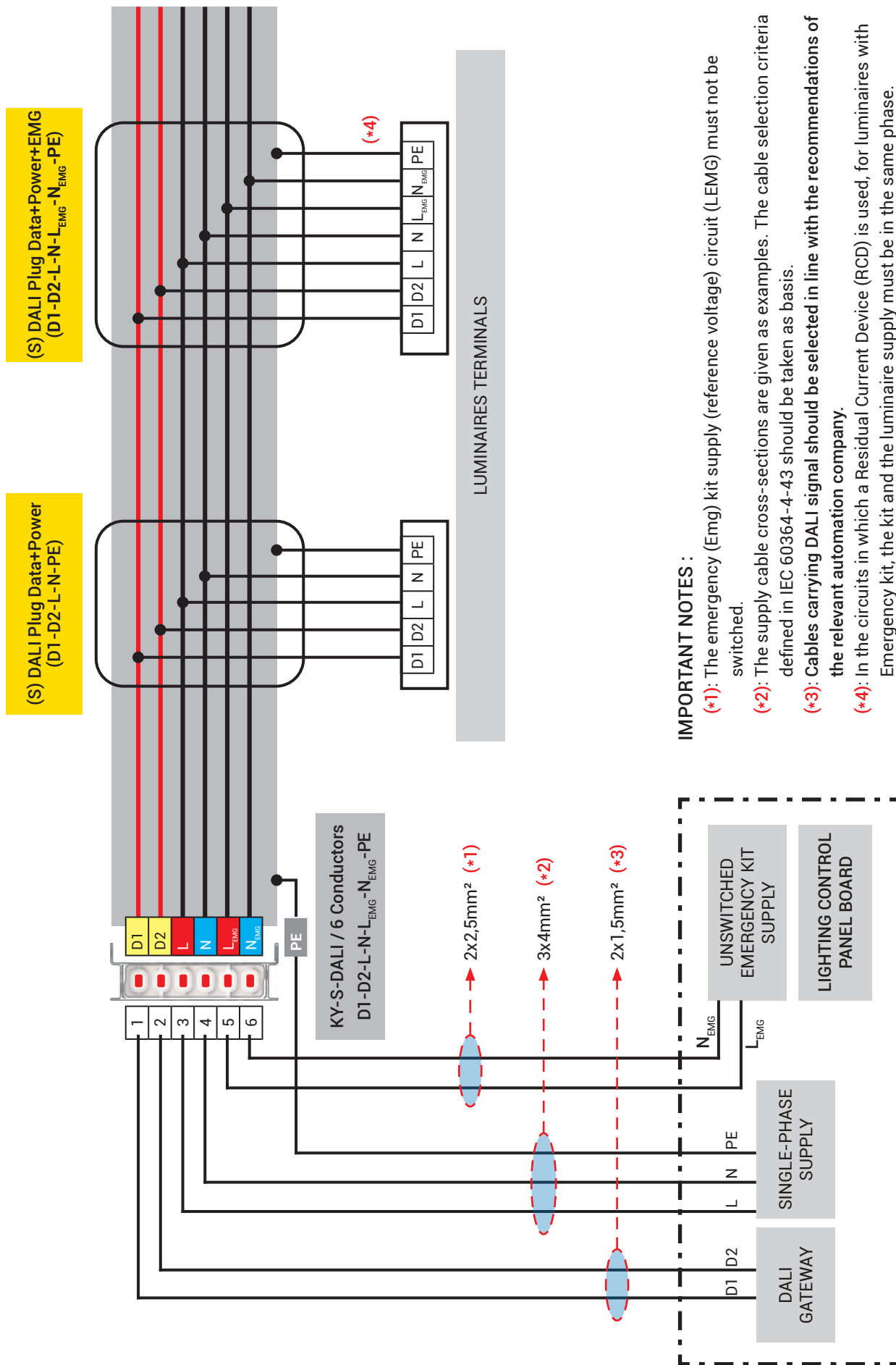

E-LINE KY-S

KY-S-DALI Busbar (5 Conductors/D1-D2-L-N-L_{EMG}-P_{housing}) Principle Connection Circuit Diagram (Common Neutral) With Residual Current Device (RCD)

CAUTION :: If there is a Residual Current Device (RCD) in the circuit!..

IMPORTANT NOTES :

- (*1): The emergency (Emg) kit supply (reference voltage) circuit (LEMG) must not be switched. If a residual current device (RCD) is to be used in the panel board, this supply must be taken after the "RCD" output.
- (*2): The supply cable cross-sections are given as examples. The cable selection criteria defined in IEC 60364-4-43 should be taken as basis.
- (*3): Cables carrying DALI signal should be selected in line with the recommendations of the relevant automation company.
- (*4): In the circuits in which a Residual Current Device (RCD) is used, for luminaires with Emergency kit, the kit and the luminaire supply must be in the same phase.

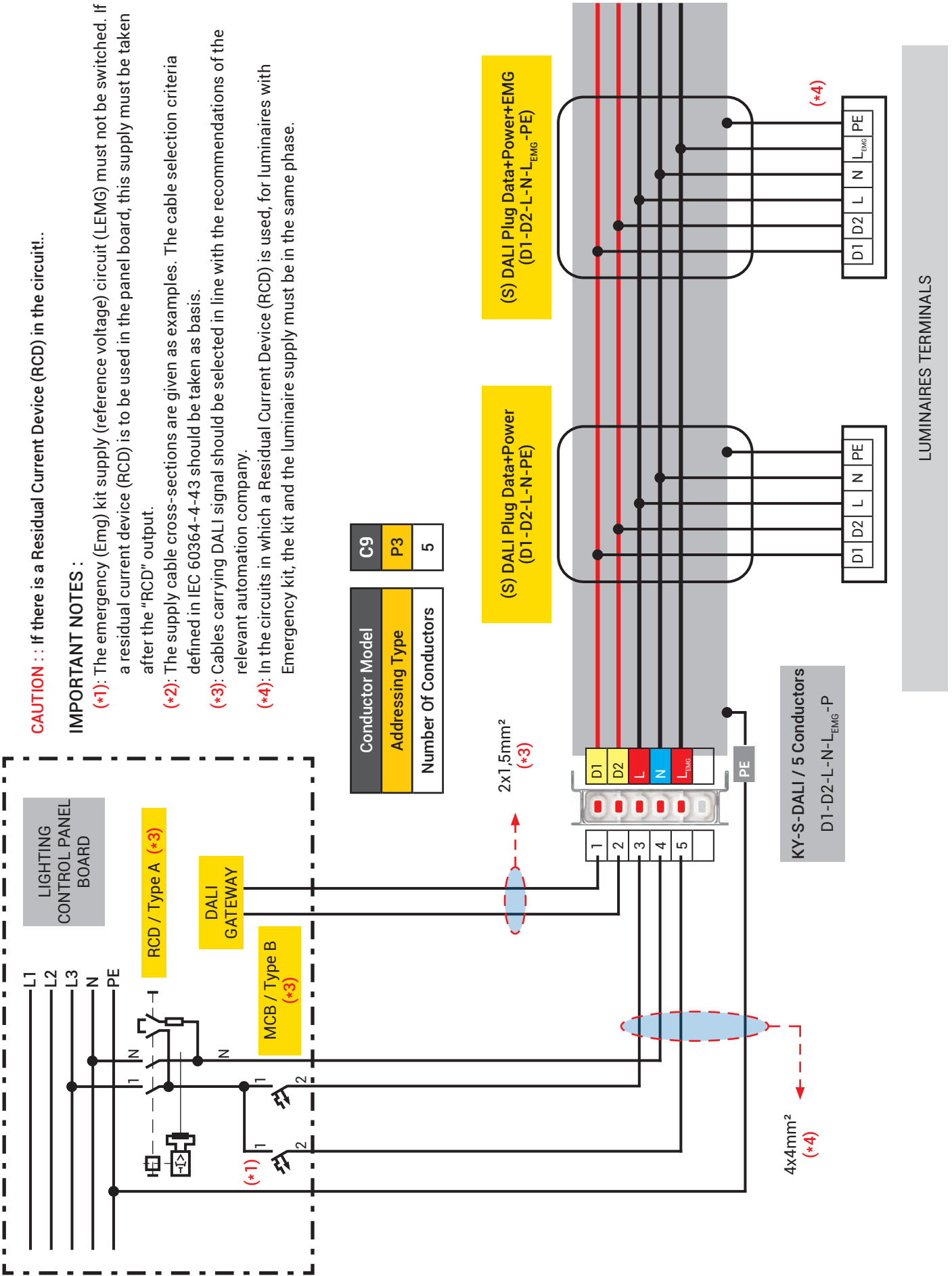

Conductor Model	C9
Addressing Type	P3
Number Of Conductors	5

(S) DALI Plug Data+Power+EMG (D1-D2-L-N-L_{EMG}-PE)

(S) DALI Plug Data+Power (D1-D2-L-N-PE)

KY-S-DALI / 5 Conductors
D1-D2-L-N-L_{EMG}-P

LUMINAIRES TERMINALS

E-LINE KY-S

KY-S-DALI Busbar (4 Conductors / D1-D2-L-N-Pe_{Housing}) Principle Connection Circuit Diagram

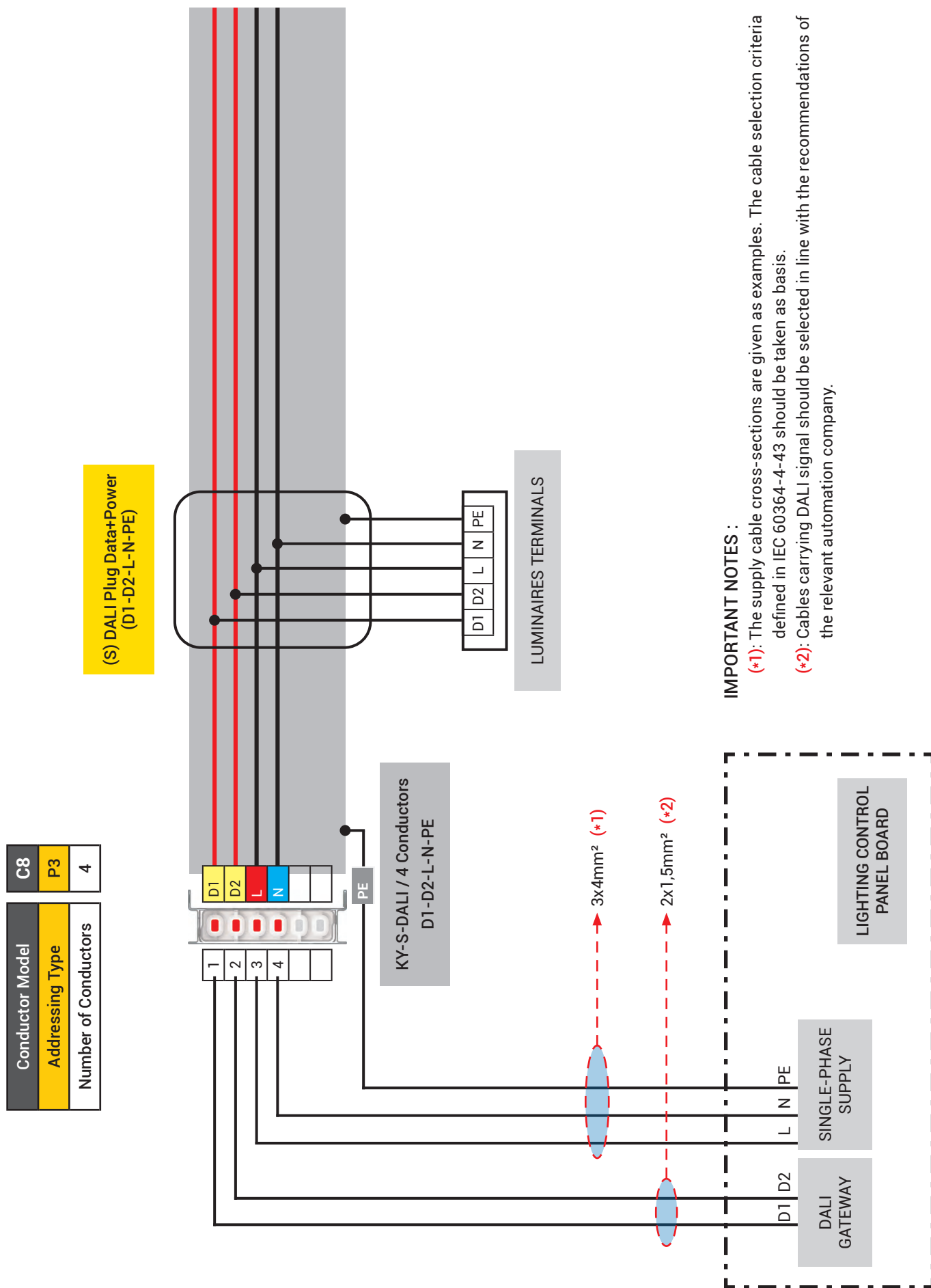

E-LINE KY-S

KY-S-DALI Busbar (6 Conductors / D1-D2-L1-L2-L3-N-Pe_{Housing})

Principle Connection Circuit Diagram

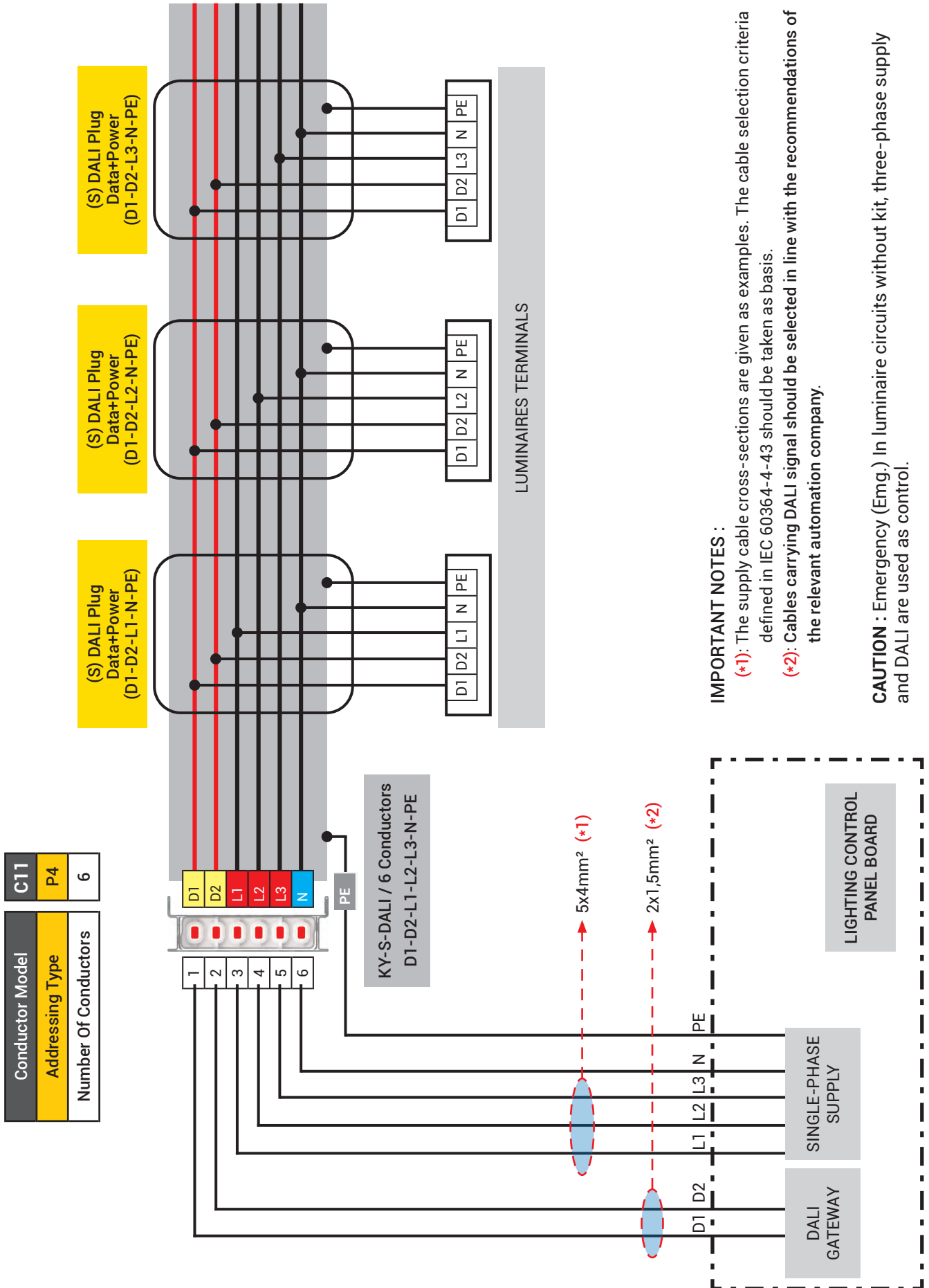

E-LINE KY-S 25-40-63A PLUG-IN BUSBAR SYSTEM PRODUCT OVERVIEW

- 1- KY-S Busbar system is manufactured in accordance with the international IEC 61439-6 standard. It has type test certificates from international test laboratories for each Current Rating.
- 2- Nominal isolation voltage of the busbar duct system is 690 V.
- 3- KY-S Busbar system tin-plated electrolytic copper with 25-40-63 A current values.
- 4- KY-S Busbar system conductors are insulated completely with "halogen free" and flame retardant plastic material. The plug-in opening points are stripped to create a connection area.
- 5- KY-S Busbar system is manufactured in standard lengths of 3m and 1m, with 3 and 1 plug-in openings in total on one side. The number of openings can be increased on special requests. In addition, there is a sealed and hinged, halogen-free and flame-proof plastic protection cover that provides IP55 protection on the plug-in openings
- 6- KY-S Busbar system is manufactured with different functions in various conductor numbers up to 6 (six) conductor structures independent from each other and with tap-off from one side. The number of conductors, phase and functional configuration alternatives are as follows;
 - a) 2 Conductor configuration: L-N-PE (housing) (Addressing type-P1)
 - b) 3 Conductor configuration: L-N-CPE (Addressing type-P1)
 - c) 4 Conductor configuration: L1-L2-L3-N-PE (housing) (Addressing type-P1)
L-N-LEMG-N_{EMG}-PE (housing) (Addressing type-P2)
 - d) 5 Conductor configuration: L1-L2-L3-N-CPE (Addressing type-P1)
L1-L2-L3-N-L_{EMG}-PE (housing) (Addressing type-P2)
 - e) 6 Conductor configuration: L1-L2-L3-N-L_{EMG}-N_{EMG}-PE (housing) (Addressing type-P2)
- 7- There are special insulator fixing pieces suitable for the housing structure to accommodate the conductors at the plug-in current points.
- 8- KY-S Busbar system joints are in a plug-in structure. The joint contacts of conductors are silver-plated. With the double-sided spring (jawed contact) pressure method, the joint is prevented from loosening. The joint structure with terminals that will allow loosening is not used. In addition, the plug-in type joint cover, which prevents the joints from stretching and deflection, can be easily installed without screws and without the need for any hand tools.
- 9- KY-S Busbar trunking is in IP 55 protection degree and IK07 mechanical impact withstand class.
- 10- The housing of KY-S Busbar system is 0.50 mm thick as standard and is manufactured from galvanized sheet metal. On request, it can also be manufactured with electrostatic oven painted in RAL 7038 or other colours on galvanized sheet.
- 11- The contacts of tap-off plugs and boxes are silver-plated, they have a structure to press the conductors inside the busbar from both sides, and the steel spring protected jawed contact structure that prevents loosening.
- 12- The KY-S Busbar system has standard fixing apparatus and fixing elements suitable for its external structure and is produced by the manufacturer. Fixing elements can also carry 50 mm cable duct at the same time by using additional small pieces.

The cross-sections of Phase and Neutral conductors are manufactured as follows;

 - 2.5 mm² for 25A;
 - 4.9 mm² for 40A;
 - 8 mm² for 63A.

• PE (Housing) is used as the housing protection conductor and the equivalent copper cross-sectional area is 7.60 mm².

• CPE (Clean Earth-Clean Protection Conductor) is a separate and independent conductor and its cross-sectional area is same with the ones of phase conductors.
- 13- KY-S-DALI model is used in lighting automation circuits with "DALI" communication protocol, in "DALI" ballast control applications at the same time with luminaire supply.
- 14- In KY-S-DALI model, the number of conductors, phase and functional configuration alternatives are as follows;
 - a) 4 Conductor configuration: D1-D2-L-N-PE (housing) (Addressing type-P3)
 - b) 5 Conductor configuration: D1-D2-L-N-L_{EMG}-PE (housing) (Addressing type-P3)
 - c) 6 Conductor configuration: D1-D2-L-N-L_{EMG}-N_{EMG}-PE (housing) (Addressing type-P3)
 - d) 6 Conductor configuration: D1-D2-L1-L2-L3-N-PE (housing) (Addressing type-P4)
- 15- The lower housing-ear, upper housing and cable gland colours and physical addressing structures (housing tabs) of the tap-off plugs and boxes to be installed in KY-S busbar and Dali and Emergency Kit (Emergency) plugs are manufactured as "different" to prevent misuse. It is possible to distinguish easily which phase the power is supplied from, the control function, plug and box types from these colours on them.
- 16- KY-S busbar can be hung with 1.5m, 2m and 3m hanger intervals, not exceeding the maximum permissible payload weights that can be applied from single or multiple points, including joints. Busbar, transport and lateral vibration and seismic hangers are manufactured originally. All of these original hangers must be used, taking into account the region, area, busbar structure and lengths used.

CE DECLARATION OF CONFORMITY

Product Group E-Line KY-S Busbar Systems

Manufacturer EAE Elektrik Asansor End. İnşaat San. ve Tic. A.S.
Akcaburgaz Mahallesi, 3114. Sokak, No:10, 34522
Esenyurt - Istanbul

The objects of the declaration described below is in conformity with the relevant Union harmonisation legislation. This declaration of conformity is made under the responsibility of the manufacturer.

Standard:

IEC 61439-6

Low-voltage switchgear and controlgear assemblies - Part 6: Busbar trunking systems

CE - Directive:

2014/35/EU "The Low Voltage Directive"
2014/30/EU "Electromagnetic Compatibility (EMC) Directive"
2011/65/EU "Restriction of the use of certain hazardous substances (RoHS)"

Technical Document Preparation Official::

EAE Elektrik Asansor End. Insaat San. ve Tic. A.S.
Akcaburgaz Mahallesi, 3114. Sokak, No:10 34522 Esenyurt-Istanbul

Mustafa AKÇELİK

Date

10.05.2024

Document Authorized Signatory

Elif Gamze KAYA OK
Deputy General Manager



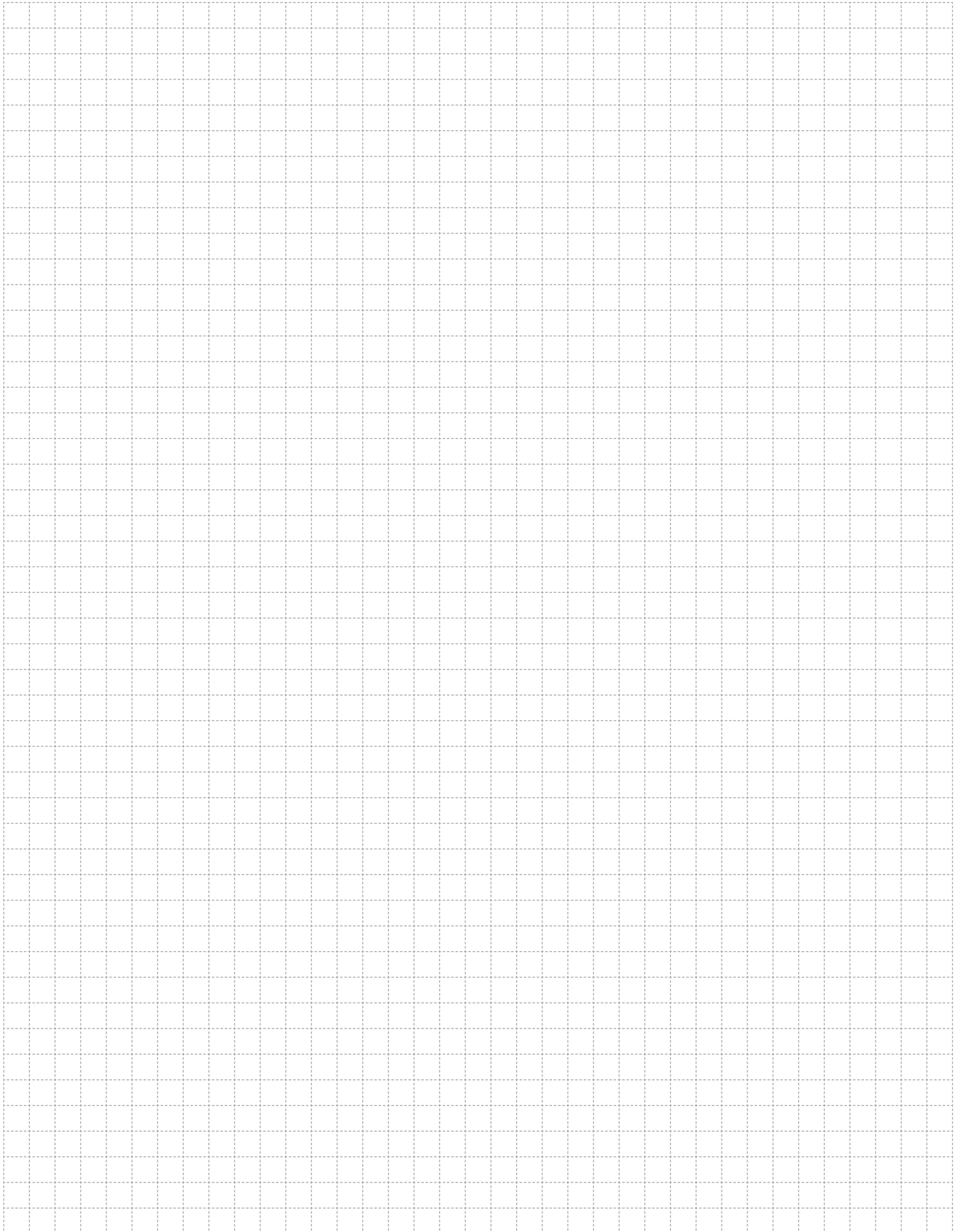

SUSTAINABLE FUTURE

Sustainability Management at EAE Elektrik



As part of our goal to support sustainable development and green transformation, measuring, evaluating, and managing all economic, environmental, and social impacts resulting from our sustainability practices is a key governance priority for EAE Elektrik. We act with great care in analyzing, monitoring, and managing the economic, environmental, and social impacts and risks that arise throughout our value chain in both our national and global operations.

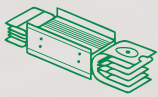

Busbar Systems

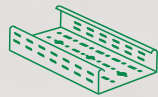

Cable Tray Systems

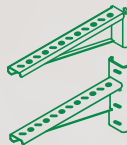

Support Systems



Trolley Busbar Systems



Fit-Out Solutions

"We are working together with all our stakeholders to develop the electrical technologies that will build the future."

You can visit our sustainability website at surdurulebilirik.eae.com.tr



#FutureTogether

EAE Elektrik
Head Office

Akcaburgaz Mahallesi,
3114. Sokak, No: 10 34522
Esenyurt - Istanbul - Turkiye
Tel: +90 (212) 866 20 00
Fax: +90 (212) 886 24 20

EAE DL 3 Factory
Busbar

Gebze IV Istanbul Makine ve Sanayicileri
Organize Bolgesi, 6.Cadde,
No:6 41455 Demirciler Koyu,
Dilovasi - Kocaeli - Turkiye
Tel: +90 (262) 999 05 55
Fax: +90 (262) 502 05 69



Please visit our website for the updated
version of our catalogues.
www.eaelectric.com



Catalogue 51 - En. / Rev. 04 1000 Pcs. 24/12/2025
D.S.

EAE has full right to make any revisions or changes on this catalogue without any prior notice.