

# E-LINE URC

Dynamic Busbar Systems

[www.eaelectric.com](http://www.eaelectric.com)

# EAE GROUP IN NUMBERS



## Since 1973

EAE Group of Companies started its journey in the electrical sector in 1973 with the establishment of EAE Elektrik. Since its founding, EAE has grown rapidly, expanding its production and areas of operation by incorporating EAE Lighting in 1983, EAE Machinery in 1996, EAE Electrotechnics in 2004, and EAE Technology in 2009.

EAE carries out its production activities in accordance with ISO 9001 Quality Management, ISO 14001 Environmental Management, ISO 14064-1 Greenhouse Gas Management System, ISO 45001 Occupational Health and Safety Management, ISO 10002 Customer Satisfaction Management, ISO 50001 Energy Management System, and ISO 27001 Information Security Management System standards.



**50+**  
Years Experience



**8**  
Active Factories



**370.000m<sup>2</sup>**  
Enclosed Space



**3**  
R&D Centers



**150+**  
Countries Exported To

# CONTENTS

---

<b>E-LINE URC</b>	
General Features .....	<b>2-3</b>
Introduction and Applications .....	<b>4</b>
<b>E-LINE URC-1</b>	
Order Coding System, Technical Features and Standard Straight Length .....	<b>5</b>
Current Collector .....	<b>6</b>
Systems Components .....	<b>7-9</b>
Voltage Drop .....	<b>10</b>
Installation Manual .....	<b>11-12</b>
Offer Request Form .....	<b>13</b>
<b>E-LINE URC-2</b>	
Order Coding System, Technical Features and Standard Straight Length .....	<b>15</b>
Current Collector .....	<b>16</b>
Systems Components .....	<b>17-19</b>
Voltage Drop .....	<b>20</b>
Installation Manual .....	<b>21-22</b>
Offer Request Form .....	<b>23</b>
Declaration .....	<b>24</b>

# E-LINE URC

## General Features



The E-Line URC range is designed to supply continuous power to moving machines. The system is easy to install and can be used in both indoor and outdoor installations. The E-Line URC system offers a safe solution for long runs because there are no moving cables. This eliminates the possibility of accidents and malfunctions associated with moving cables.

**Standard Length** : 4m (Aluminium Conductor URC-1)  
6m (Aluminium Conductor URC-2)

**Operating Speed** : Maximum 200m/min.

### System Components:

The E-Line URC comprises an end feed unit which supplies power to the conductors which are manufactured from either, aluminium with stainless steel contact surface. The power is conducted to the machine through a moving collector which runs along the length of the conductors. An expansion unit protects the installed system from external mechanical stresses. End caps are fitted to each end of the busbar run to safely complete the installation. The system is supported by sliding hangers.

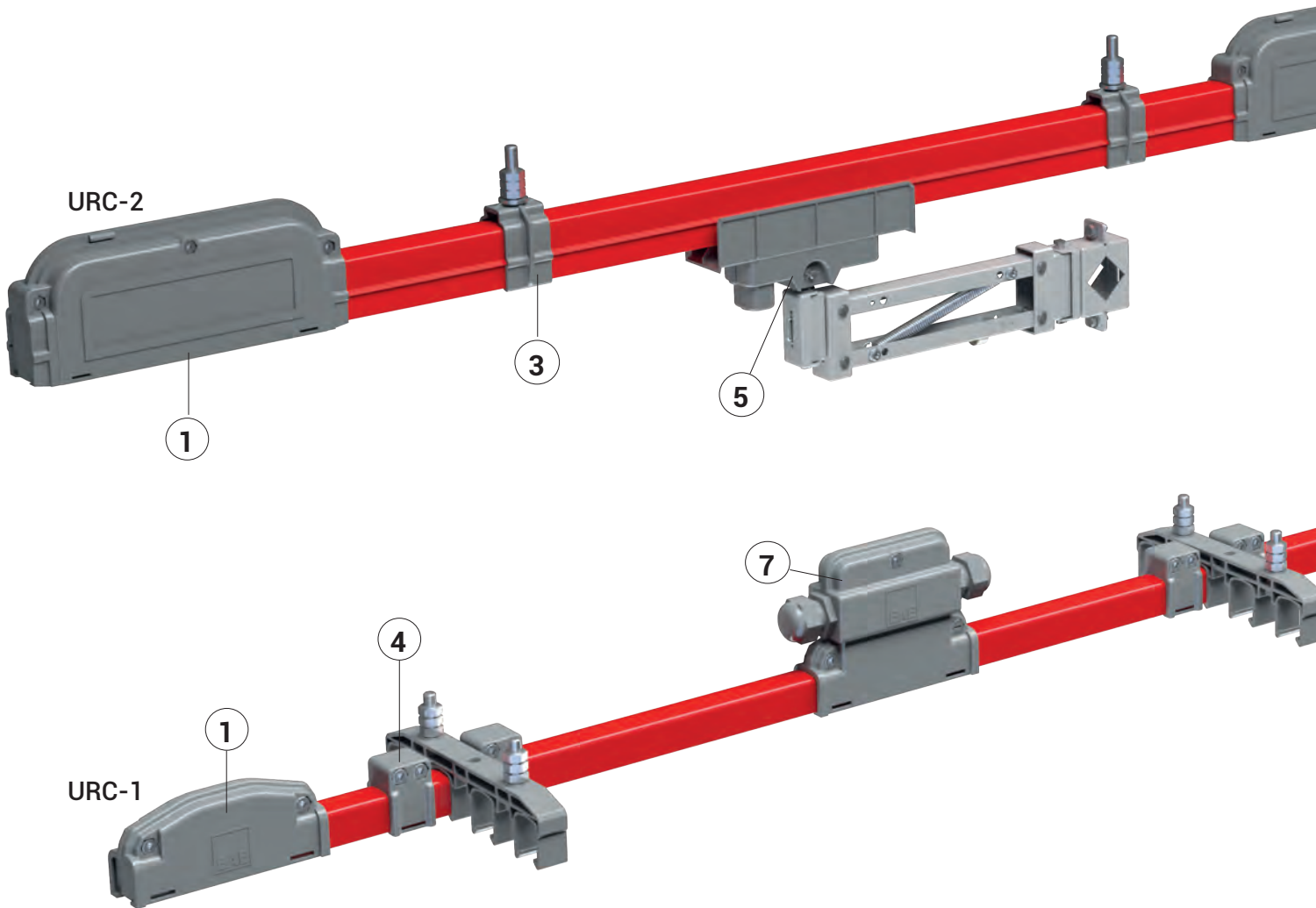

### Personnel Safety:

- Personnel safety is assured by the insulation of the conductors.
- Protection Degree is IP23.

# E-LINE URC

## Safety

- The E-Line URC system offers a safe solution for long runs because there are no moving cables.
- This eliminates the possibility of accidents and malfunctions associated with moving cables.
- The system can be used safely for outdoor applications, the component materials used give a long life solution.

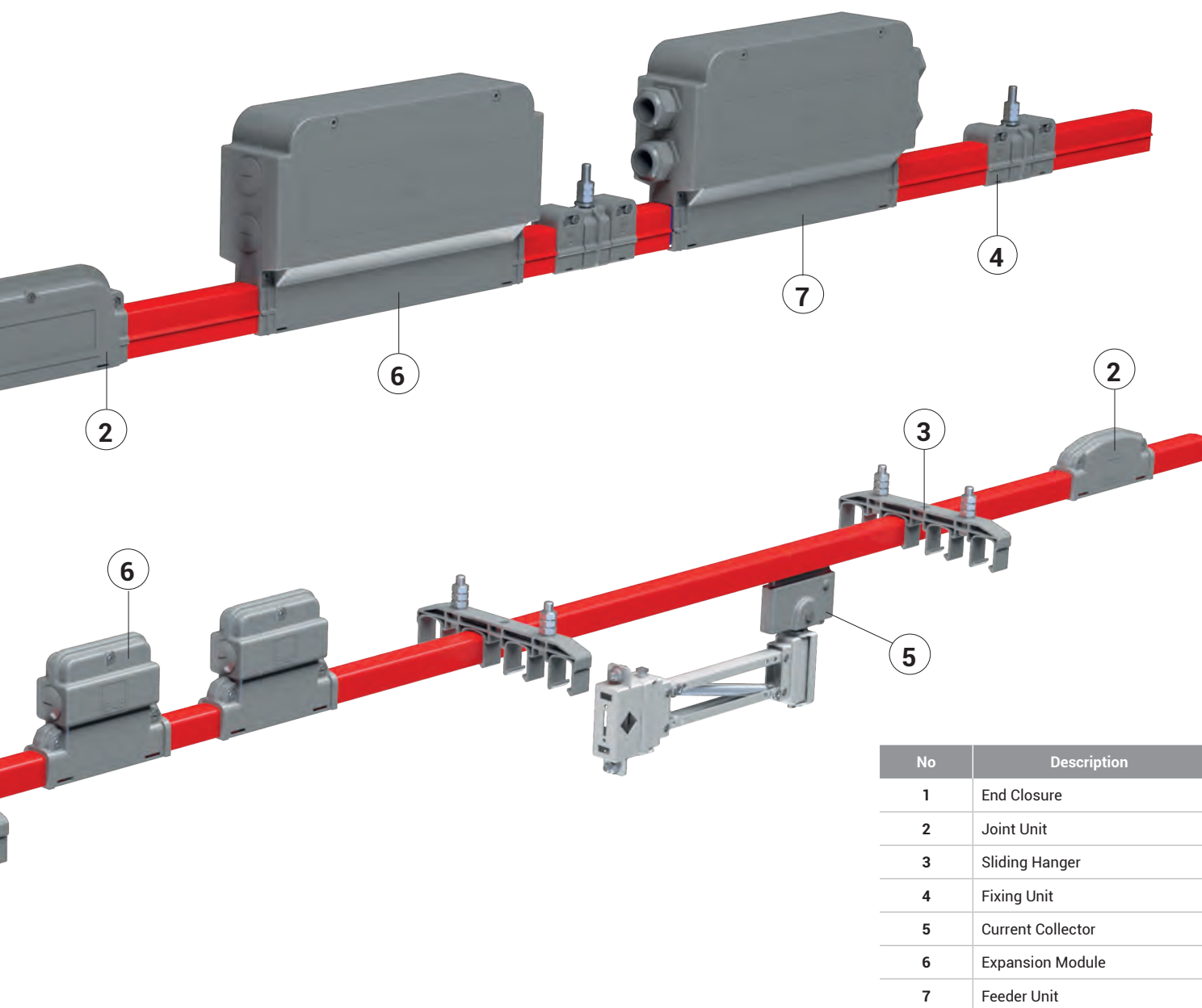

### Functionality:

- The system has a long life. On higher current versions the conductors are aluminium with a stainless steel V conductor surface.
- The system can carry serial collectors to allow for more than one machine to be fed from the same busbar.

# E-LINE URC

## Introduction

### Dynamic Busbar Systems



The E-Line URC range is designed to supply continuous power to moving machines. The E-Line URC system offers a safe solution for long runs. The system is easy to install and can be used in both indoor and outdoor installations.

### Applications

- Port, construction and cranes
- AS/RS storage systems
- Moving playground systems
- Moving Ceiling and Door Systems
- Assembly and test lines
- Monorail systems
- Elevator and lift systems

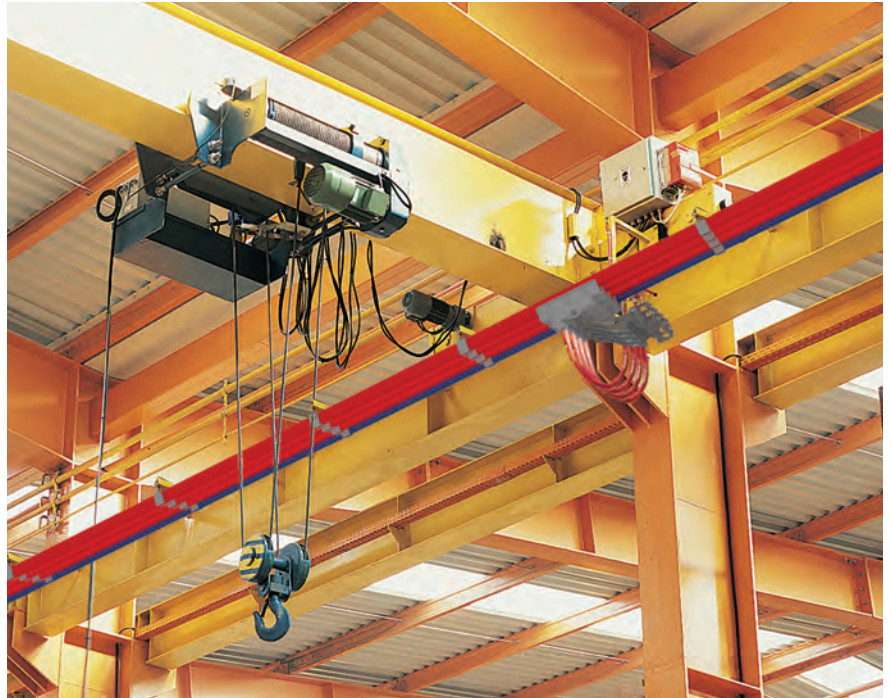

# E-LINE URC

## Order Coding System

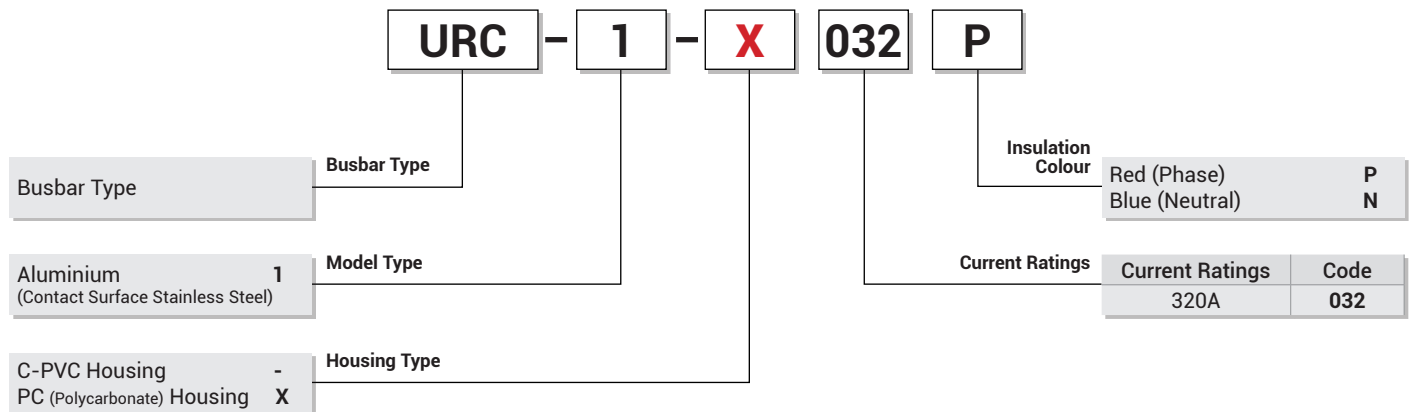

-40°C +55°C for the temperature range C-PVC Housing.  
 -40°C +100°C for the temperature range PC (Polycarbonate) Housing must be used.

### Technical Features

Busbar Code		032
Rated Current	A	320
Conductor Cross-section Area	mm <sup>2</sup>	120
Rated Voltage	AC - V	1000
Resistance (20°C)	R <sub>20</sub> (mΩ/m)	0,286
Resistance (32°C)	R <sub>35</sub> (mΩ/m)	0,353
Reaktance	X (mΩ/m)	0,160
Impedance	Z (mΩ/m)	0,388
Weight	kg/m	0,580

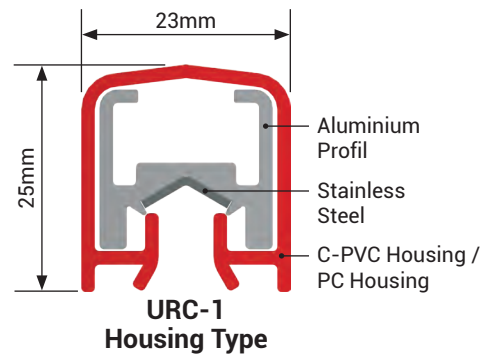

- Aluminium Contact Surface Stainless Steel.
- Protection Degree IP23.
- Standard length is 4m.

- Ambient temperature is :
- C-PVC for housing -40°C +55°C
  - PC Polycarbonate) is for housing -40°C +100°C

### Standard Straight Length

Aluminium Conductor	URC-1 (C-PVC Housing)		URC-1-X (PC Housing)	
	(-40°C +55°C)		(-40°C +100°C)	
	Phase	Neutral	Phase	Neutral
URC-1 032 (320A)	3271455	3271457	3271454	3271456

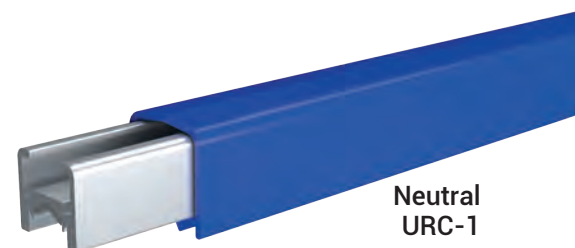
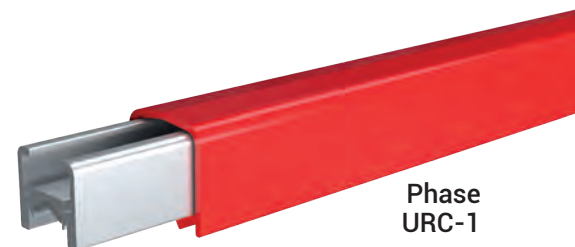
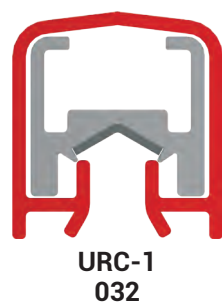

# E-LINE URC

## Current Collector

### URC-1 Current Collector



Description	Order Code
URC-1 100A Current Collector (Y)	3233907

#### URC-1 Technical Features:

- Copper-Graphite Brush
- 200m/min. maximum operating speed
- 100A 1x16mm<sup>2</sup> H01N2-D 2m standard cable length

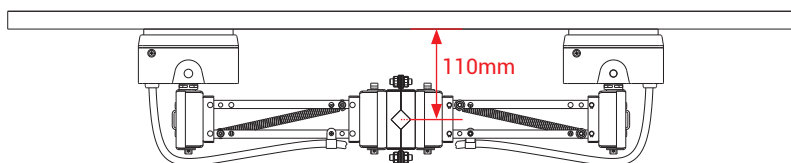

- The distance between busbar and current collectors support should be 110mm.
- The contact pressure of current collector is 10N.

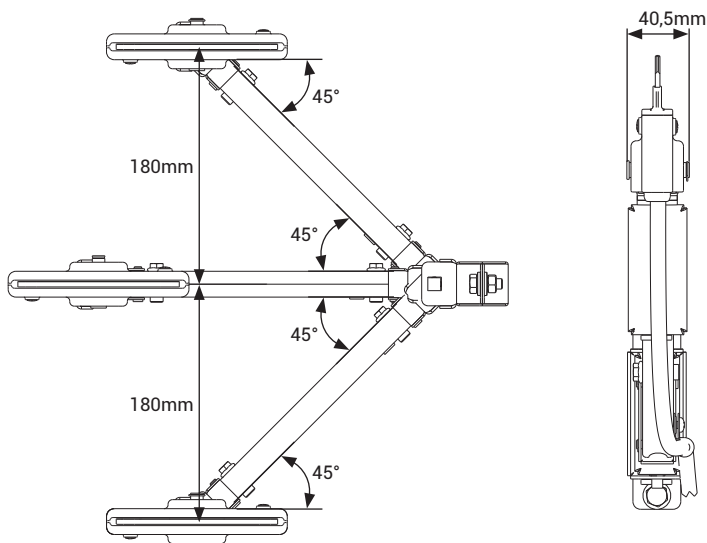
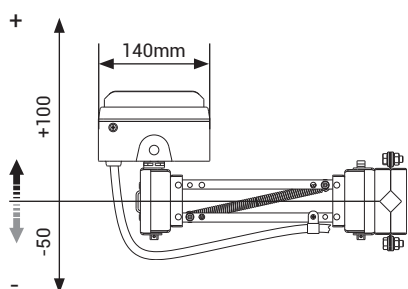

### URC-1 Current Collectors Support

Description	L (mm)	Order Code
URC-1 Current Collectors Support	400	3034551
URC-1 Current Collectors Support	600	3188390

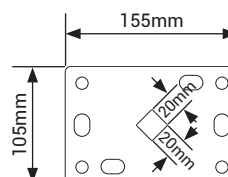
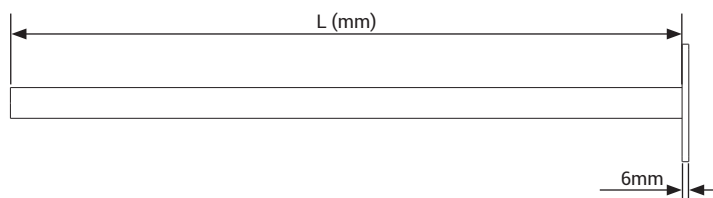
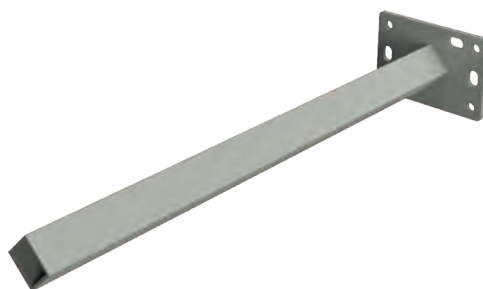

# E-LINE URC

## System Components

### URC-1 Feeder Units



Description	Order Code
URC-1 Feeder Units	3034552

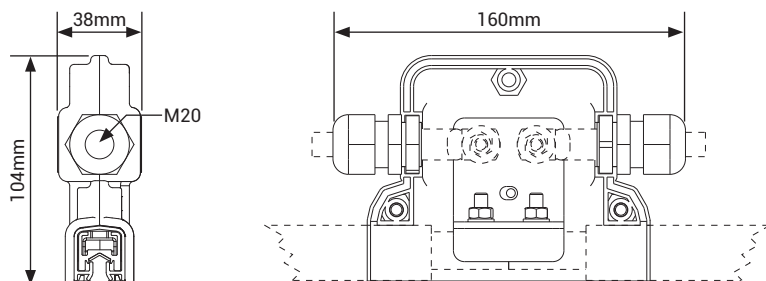

### URC-1 Joint Unit

Description	Order Code
URC-1 Joint Unit	3034582

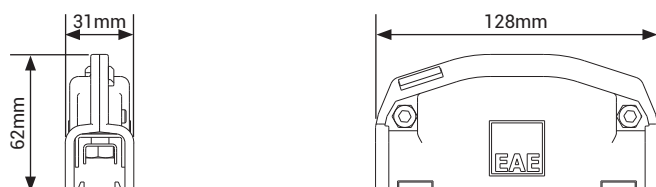

### URC-1 End Closure

Description	Order Code
URC-1 End Closure	3034571

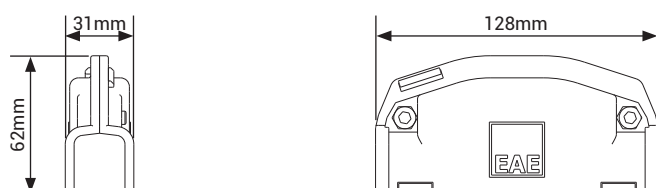

### URC-1 Fixing Unit

Description	Order Code
URC-1 Fixing Unit	3034581



# E-LINE URC

## System Components

### URC-1 Current Collector Brush Set



Description	Order Code
URC-1 Current Collector Brush Set	3158598

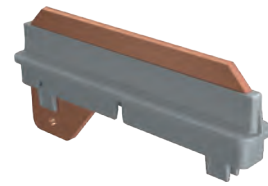

### URC-1 Sliding Hanger

Description	Order Code
URC-1 Plastic Sliding Hanger (Single)	3034558
URC-1 Plastic Sliding Hanger (Quad)	3034559
URC-1 Steel Sliding Hanger (Single)	3200541

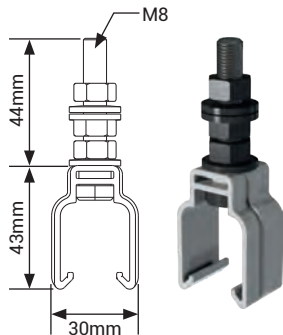
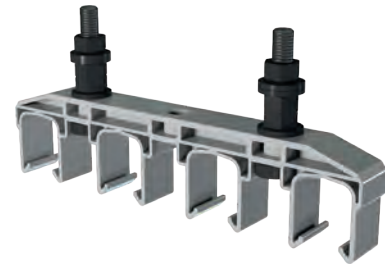

Plastic Sliding Hanger (Single)

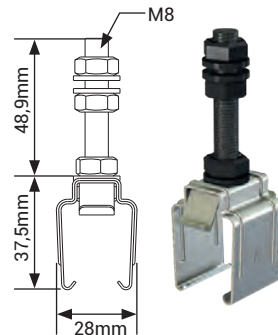

Steel Sliding Hanger (Single)

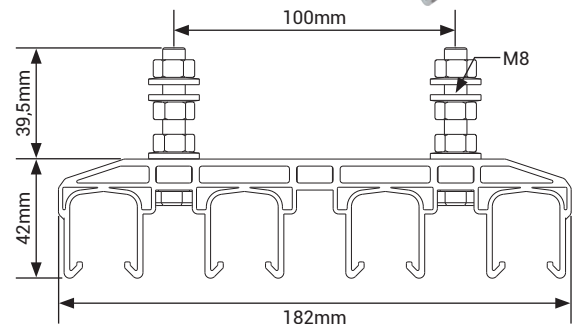

Plastic Sliding Hanger (Quad)

### URC-1 Hanger Bracket

Description	L (mm)	Order Code
URC-1 Hanger Bracket	500	3034560
URC-2 Hanger Bracket	750	3025382

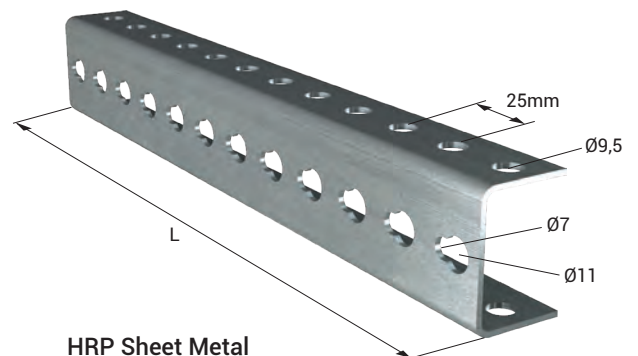
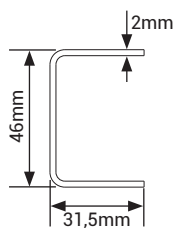

HRP Sheet Metal

### URC-1 BR Hanger Bracket Set

Description	L (mm)	Order Code
URC-1 BR Hanger Bracket Set	600	3178917
URC-2 BR Hanger Bracket Set	800	3178918

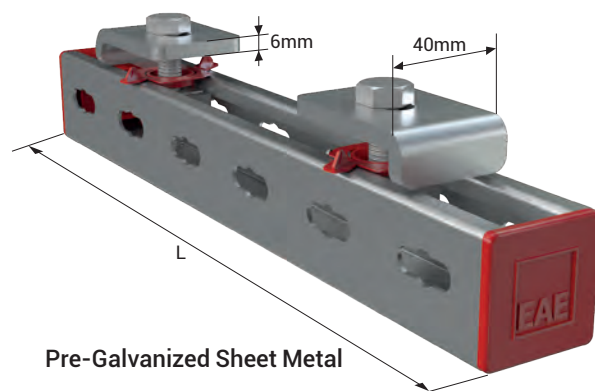
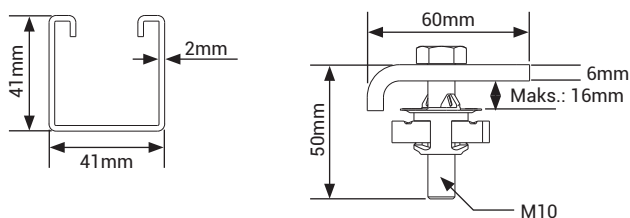

Pre-Galvanized Sheet Metal

• Please browse the MFIX catalog to see our various support solutions.

# E-LINE URC

## System Components

### URC-1 Repair Zone Module



Aluminium Conductor	C-PVC Housing		PC (Polycarbonate) Housing	
	(-40°C +55°C)		(-40°C +100°C)	
	Phase	Neutral	Phase	Neutral
URC-1 Repair Zone Module	3271445	3271448	3271444	3271446

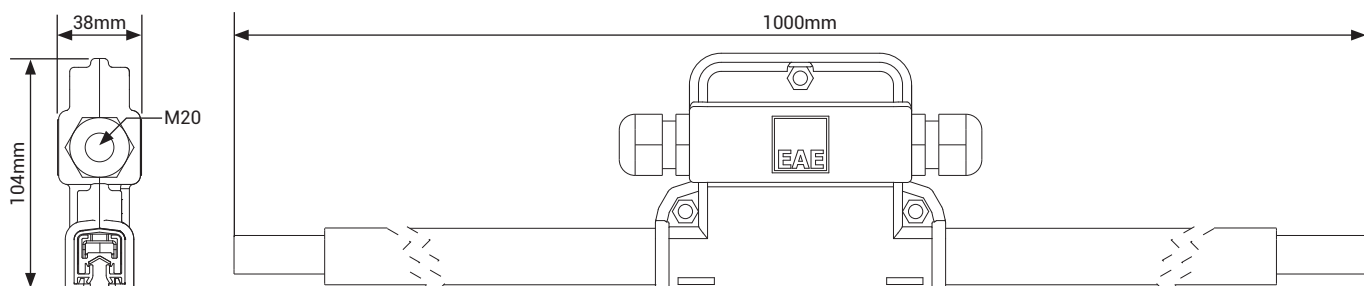
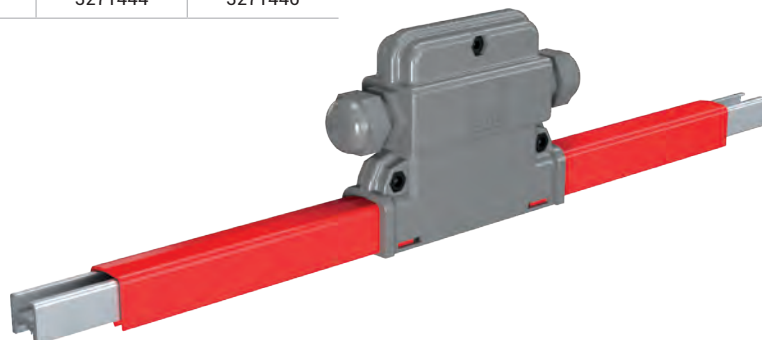

### URC-1 Expansion Module

Aluminium Conductor	C-PVC Housing		PC (Polycarbonate) Housing	
	(-40°C +55°C)		(-40°C +100°C)	
	Phase	Neutral	Phase	Neutral
URC-1 Expansion Module	3271450	3271453	3271449	3271452

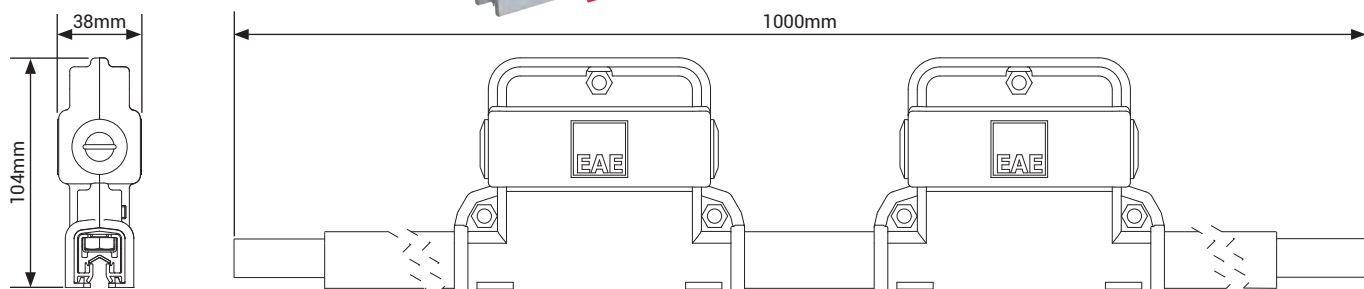
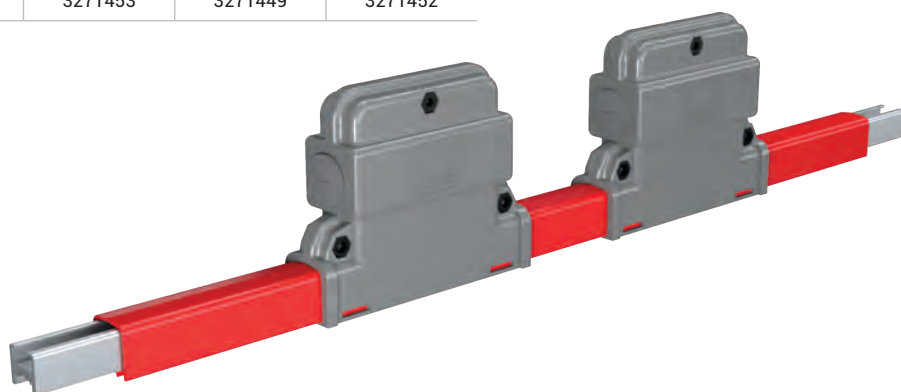

The expansion module should be used every 50 meters between the fixed points in order to protect the system from being damaged by the expansion that may occur due to heat.

The voltage drop in the busbar lines shall be inspected as per the busbar type selected according to the total current calculated based on the ambient temperature and operating period of the system. Maximum acceptable value for voltage drop is 3%.

<b>For Direct Current</b>	$\Delta U = 2 \cdot L_t \cdot I_G \cdot R$	$\Delta U =$ Voltage Drop [V]
<b>For Mono-Phase Alternative Current</b>	$\Delta U = 2 \cdot L_t \cdot I_G \cdot Z$	$I_G =$ Total Current [A]
<b>For Three-Phase Alternative Current</b>	$\Delta U = \sqrt{3} \cdot L_t \cdot I_G \cdot Z$	$R =$ Resistance of The Busbar [ $\Omega/m$ ]
		$Z =$ Impedance of The Busbar [ $\Omega/m$ ]
		$L_t =$ Calculated Hole Length [m]

**Note :** Calculation of the current drawn during first start in various motor types;  
 $I_A =$  Total current drawn in the first start of the motors [A]

For the starting current;

Three-phase asynchronous drive in direct start	$I_A = I_G \times 5 \text{ to } 6$
Slip ring rotor motor	$I_A = I_G \times 2 \text{ to } 3$
Frequency converter	$I_A = I_G \times 1,20 \text{ to } 1,50$

## Calculation of Feeding Points

When we take L as the length of the line, feeding points may be selected as shown in the diagrams below to keep the  $L_t$  voltage drop at minimum and it may be used as the hole length for the calculation of  $L_t$  voltage drop.



1 feeding point from the start  $L_t=L$

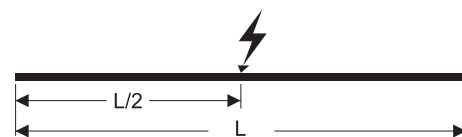

1 feeding point from the center  $L_t=L/2$



2 feeding points from the start points  $L_t=L/4$



2 feeding points  $L_t=L/6$

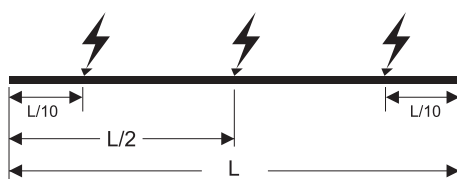

3 feeding points  $L_t=L/10$

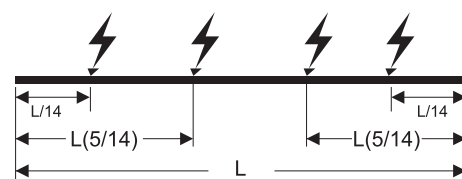

4 feeding points  $L_t=L/14$

# E-LINE URC

## Installation Manual

### General System Usage Metrics

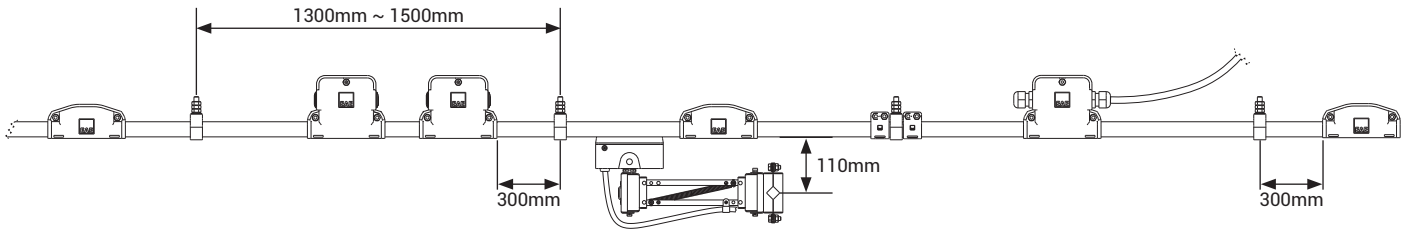

- Distance between the sliding hangers should be **1300 ~ 1500mm**.
- Distance between sliding hanger and other units (joint unit, feeder, expansion etc.) should be minimum **300mm**.

### Installation

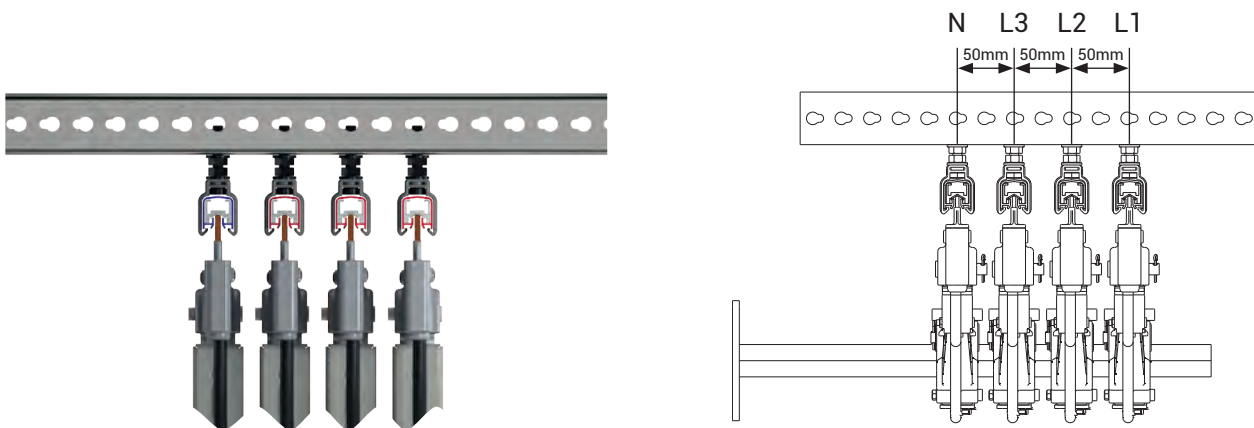

- For horizontal installation distance at least 50mm ,should be between sliding hanger axes.

### URC-1 Joint Unit Installation Manual

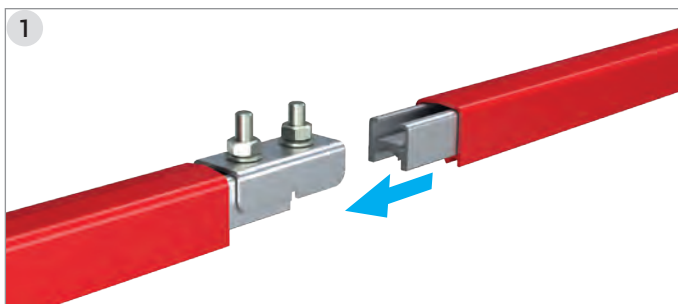

Place the joint unit between the two busbar lengths to be joined with their bolts facing upwards as shown. The notch of the joint unit should be centered at the junction of the two busbars.

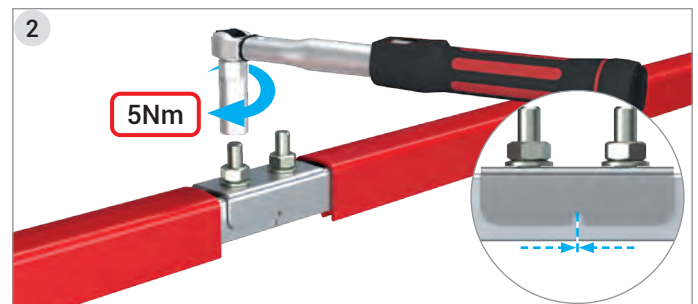

The notch of the joint unit should be centered at the junction of the two busbars. Tighten the nuts with torque wrench adjusted to 5Nm.

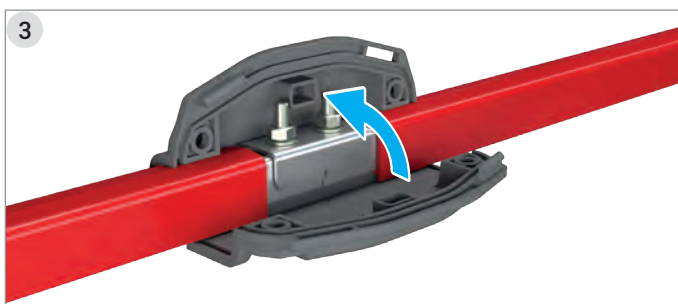

Place the joint unit covers facing each other. Put the bolts and nuts in the sockets

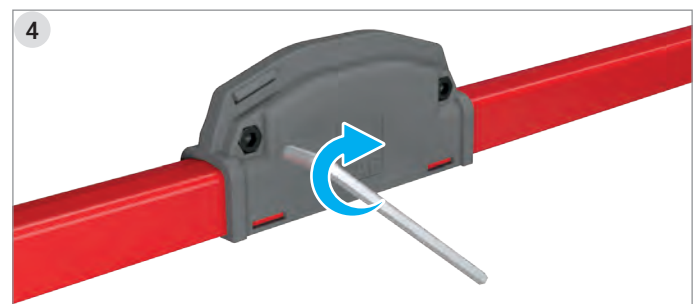

Tighten the the bolt with 5 allen wrench.

# E-LINE URC

## Installation Manual

### URC-1 Feeder Unit Installation Manual

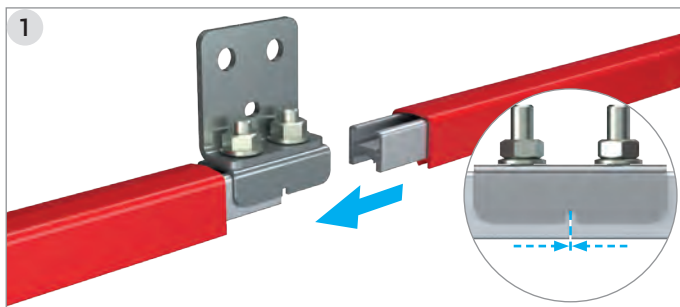

Place the joint unit between the two busbar lengths to be joined with their bolts facing upwards as shown. The notch of the joint unit should be centered at the junction of the two busbars.

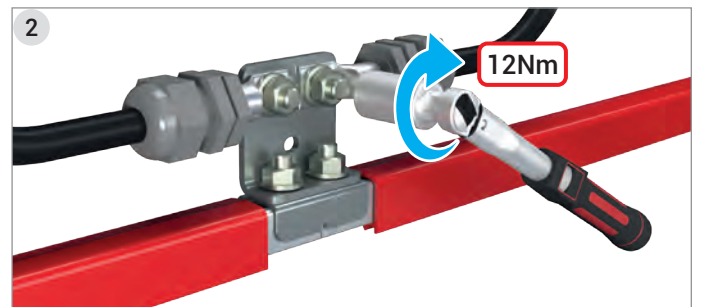

Pass the cables feeding the system through cable gland, tighten the nuts of the connecting plate with a torque wrench adjusted to 12Nm.

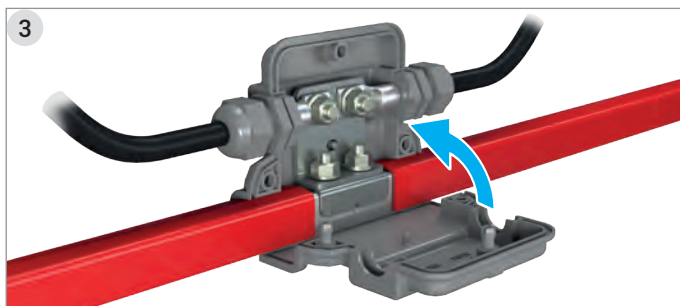

Place the feeder unit covers facing each other.

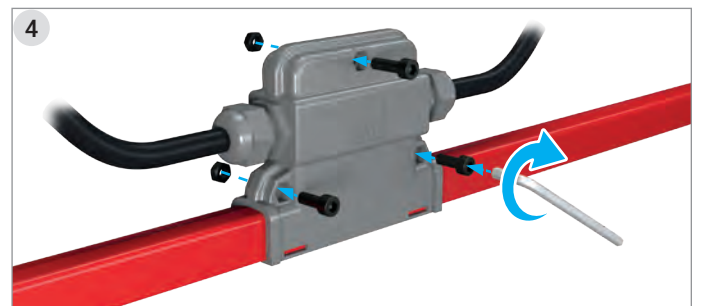

Put the bolts and nuts in the sockets. Tighten the the bolt with 5 allen wrench.

### URC-1 Expansion Unit Installation Manual

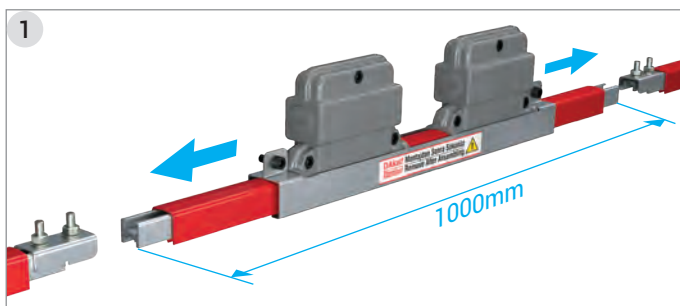

Installation of the expansion module in accordance with the joint unit installation instructions.

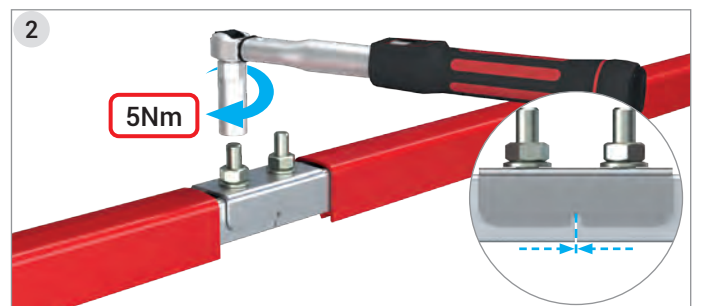

The notch of the joint unit should be centered at the junction of the two busbars. Tighten the nuts with torque wrench adjusted to 5Nm.

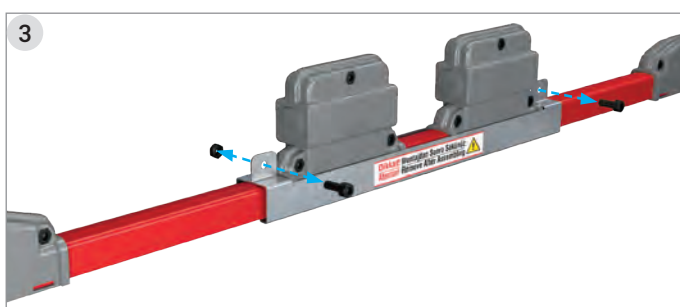

Do not open the expansion module covers. After assembly unscrew the bolts of the alignment part and remove it.

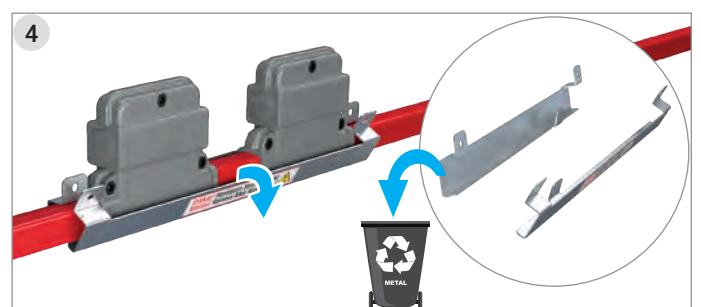

Throw the steel alignment jig into the recycling bin.

**Note:** If the alignment part is removed before assembly, the distances of the module should be adjusted as shown in the Figure 1.

# E-LINE URC

## Offer Request Form



Date :

Project Name	:	<input type="text"/>
Company	:	<input type="text"/>
Name Surname	:	<input type="text"/>
Tel	:	<input type="text"/>
E-Mail	:	<input type="text"/>
Address	:	<input type="text"/>

### General Data

Track Length	:	<input type="text"/>
Number of Cranes on Track	:	<input type="text"/>
Crane Travel Speed	:	<input type="text"/>

### Environmental Data

Operating Environment	:	<input type="checkbox"/> Indoor	<input type="checkbox"/> Outdoor
Ambient Temperature	:	<input type="text"/> °C min.	<input type="text"/> °C max.
Other Operating Conditions (Humidity, Dust, Chemical Influence, etc.)	:	<input type="text"/>	

### Electrical Data

Operating Voltage	:	<input type="text"/> Volts	<input type="checkbox"/> AC	<input type="checkbox"/> DC			
		<input type="text"/> Phases	<input type="checkbox"/> N	<input type="checkbox"/> PE			
Position and Number of Feeder	:	<input type="text"/> from End	<input type="text"/> from Middle				
Duty Cycle (%)	:	<input type="checkbox"/> 50%	<input type="checkbox"/> 60%	<input type="checkbox"/> 70%	<input type="checkbox"/> 80%	<input type="checkbox"/> 90%	<input type="checkbox"/> 100%

Motor Specifications	Crane - 1		Crane - 2		Crane - 3	
	Power (kW)	Current (A)	Power (kW)	Current (A)	Power (kW)	Current (A)
Hoist motors	<input type="text"/>	<input type="text"/>	<input type="text"/>	<input type="text"/>	<input type="text"/>	<input type="text"/>
Auxiliary motor	<input type="text"/>	<input type="text"/>	<input type="text"/>	<input type="text"/>	<input type="text"/>	<input type="text"/>
Long travel	<input type="text"/>	<input type="text"/>	<input type="text"/>	<input type="text"/>	<input type="text"/>	<input type="text"/>
Cross travel	<input type="text"/>	<input type="text"/>	<input type="text"/>	<input type="text"/>	<input type="text"/>	<input type="text"/>

### Options

Brackets Required	:	<input type="checkbox"/> Yes	<input type="checkbox"/> No
Repair Zone Required	:	<input type="checkbox"/> Yes	<input type="checkbox"/> No
		<input type="text"/> Qty	
Collector Replacement Required:		<input type="checkbox"/> Yes	<input type="checkbox"/> No
		<input type="text"/> Qty	
Descriptions	:	<input type="text"/>	

Please duplicate this page for your own use.

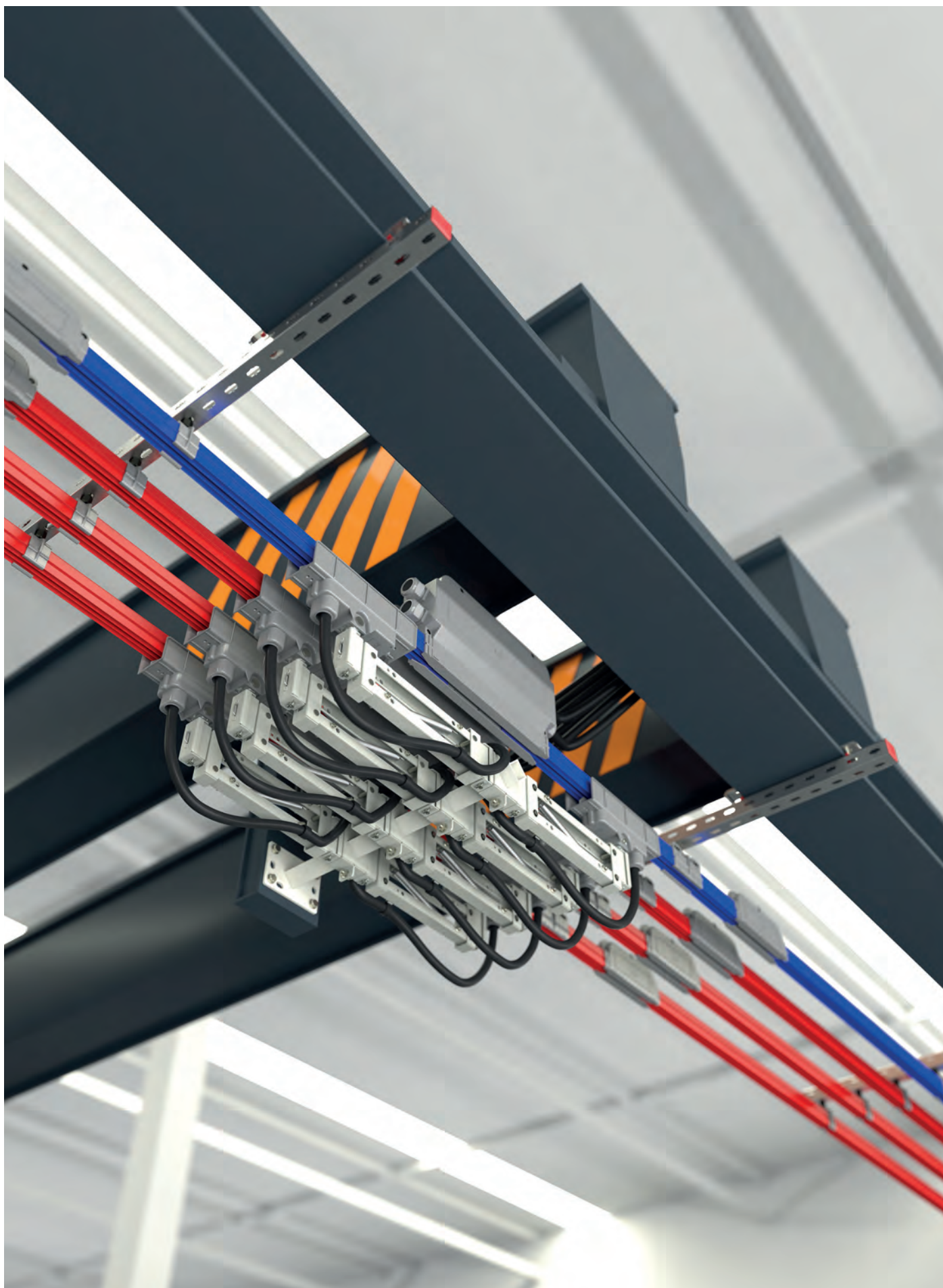

# E-LINE URC

## Order Coding System

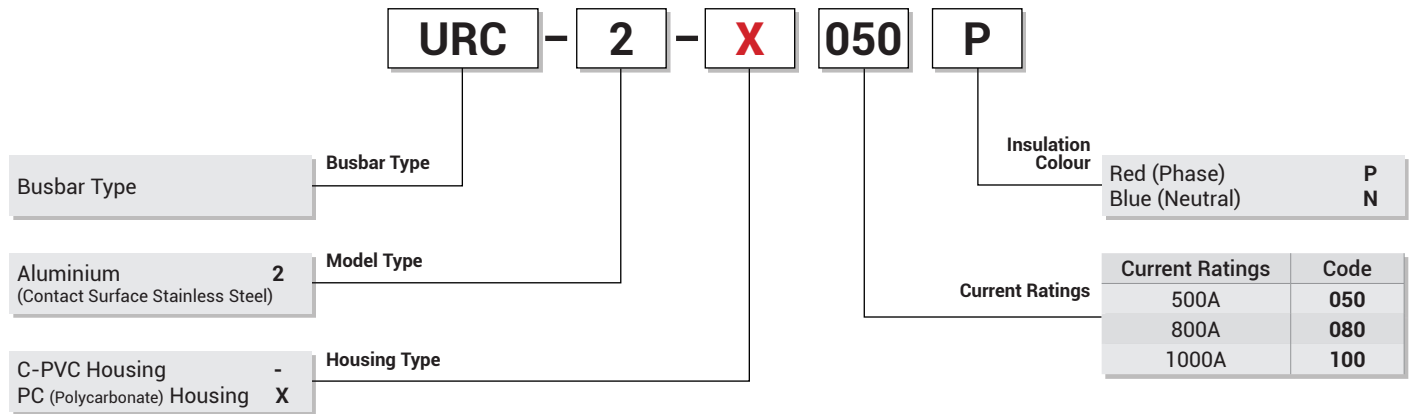

-40°C +55°C for the temperature range C-PVC Housing.  
-40°C +100°C for the temperature range PC (Polycarbonate) Housing must be used.

### Technical Features

Busbar Code		050	080	100
Rated Current	A	500	800	1000
Conductor Cross-section Area	mm <sup>2</sup>	275	460	625
Rated Voltage	AC - V	1000	1000	1000
Resistance (20°C)	R <sub>20</sub> (mΩ/m)	0,125	0,080	0,062
Resistance (32°C)	R <sub>35</sub> (mΩ/m)	0,148	0,099	0,076
Reaktance	X (mΩ/m)	0,133	0,139	0,140
Impedance	Z (mΩ/m)	0,198	0,171	0,157
Weight	kg/m	1,150	1,700	2,050

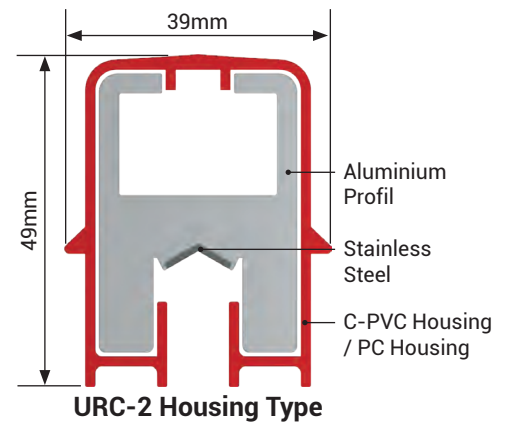

- Aluminium Contact Surface Stainless Steel.
- Protection Degree IP23.
- Standard length is 6m.

- Ambient temperature is:
- C-PVC for housing -40°C +55°C
  - PC Polycarbonate) is for housing -40°C +100°C

### Standard Straight Length

Aluminium Conductor	URC-2 (C-PVC Housing)		URC-2-X (PC Housing)	
	(-40°C +55°C)		(-40°C +100°C)	
	Phase	Neutral	Phase	Neutral
URC-2 050 (500A)	3033991	3033992	3164914	3164913
URC-2 080 (800A)	3033993	3033994	3164916	3164915
URC-2 100 (1000A)	3033971	3033972	3164918	3164917

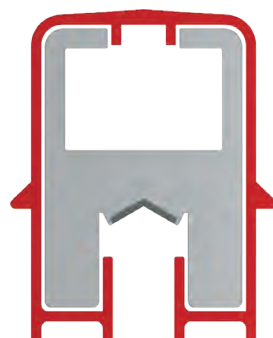
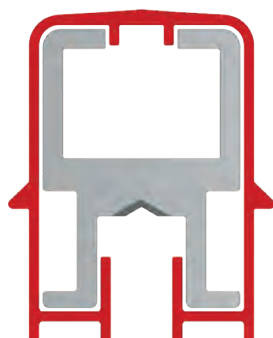
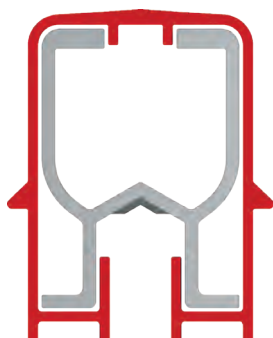
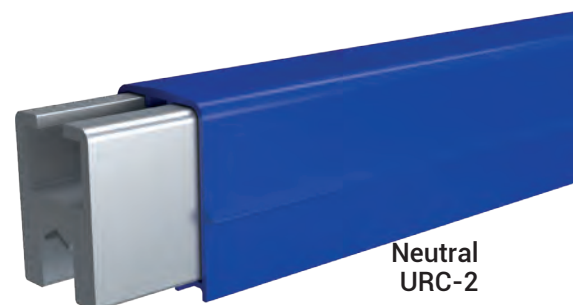
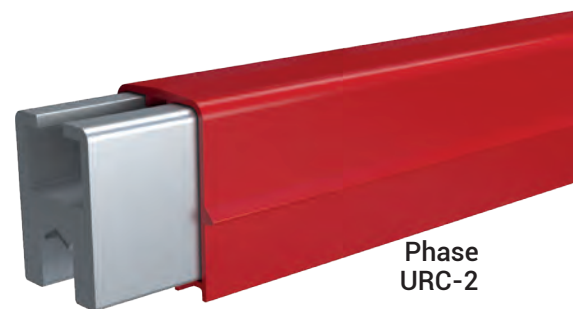

# E-LINE URC

## Current Collector

### URC-2 Current Collector



Description	Order Code
URC-2 300A Current Collector (Y)	3233908

#### URC-2 Technical Features:

- Current collector capacity is 300A
- Copper-Graphite Brush
- 200m/min. maximum operating speed
- 1x95mm<sup>2</sup> H01N2-D 3m standard cable length

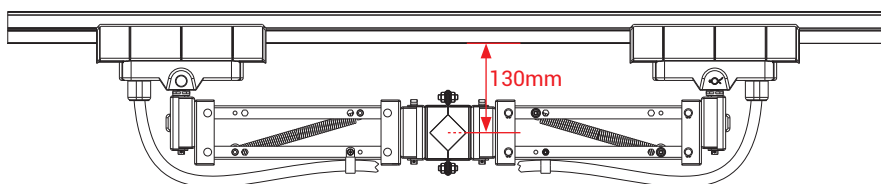
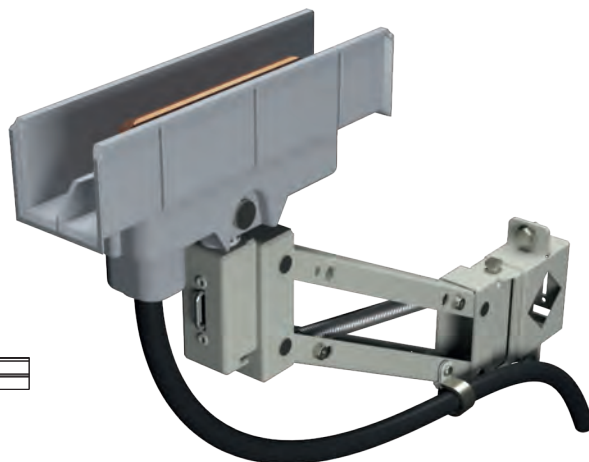

- The distance between busbar and current collectors support should be 130mm.
- The contact pressure of current collector is 50N.

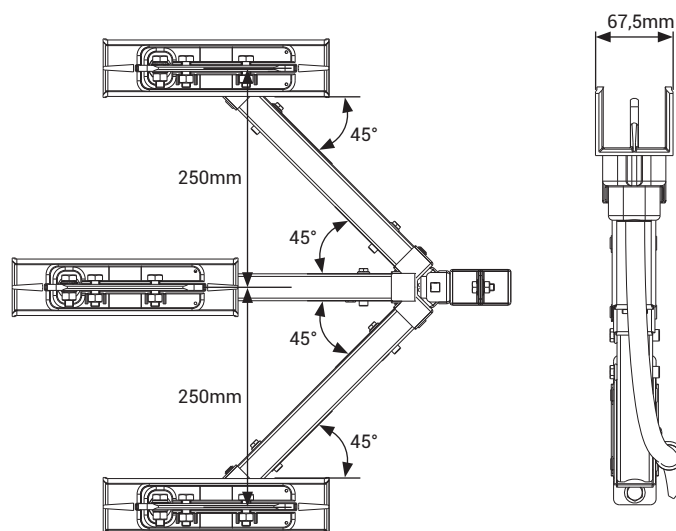
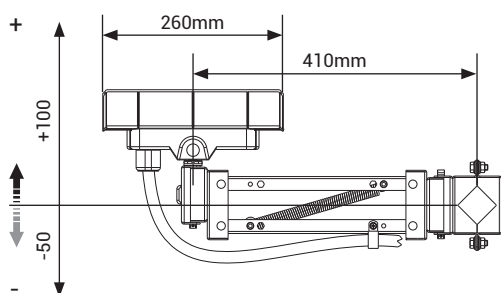

### URC-2 Current Collectors Support

Description	L (mm)	Order Code
URC-2 Current Collectors Support	600	3030410

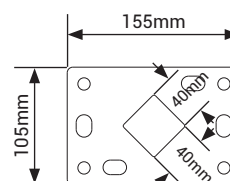
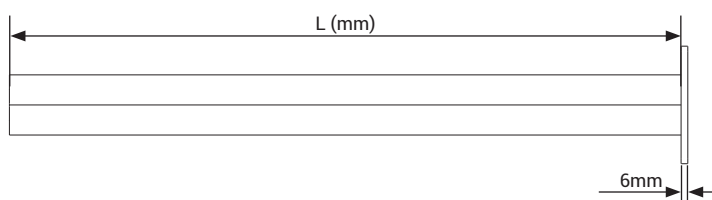
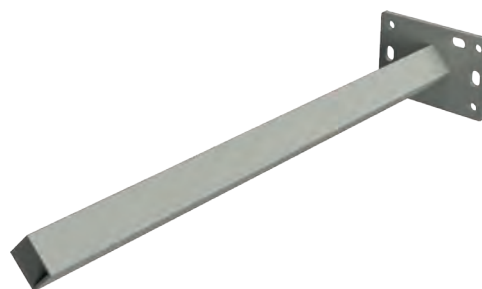

# E-LINE URC

## System Components

### URC-2 Feeder Units



Description	Order Code
URC-2 Feeder Units	3033990

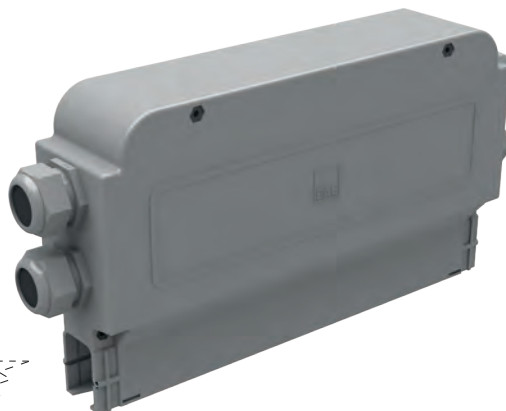
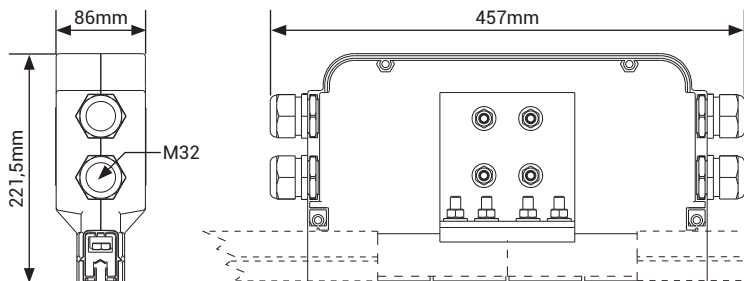

### URC-2 Joint Unit

Description	Order Code
URC-2 Joint Unit	3033995

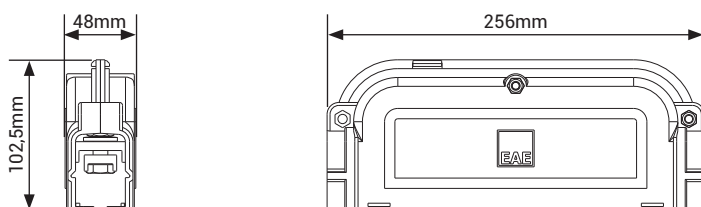

### URC-2 End Closure

Description	Order Code
URC-2 End Closure	3033977

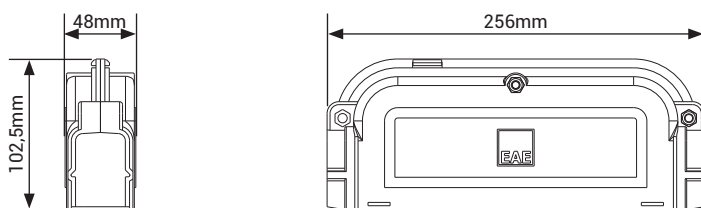

### URC-2 Fixing Unit

Description	Order Code
URC-2 Fixing Unit	3033987



# E-LINE URC

## System Components

### URC-2 Current Collector Brush



Description	Order Code
URC-2 Current Collector Brush (300A)	1003516



### URC-2 Sliding Hanger

Description	Order Code
URC-2 Plastic Sliding Hanger	3033986
URC-2 Steel Sliding Hanger	3132893

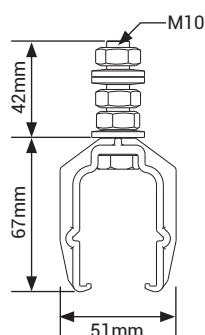

Plastic Sliding Hanger

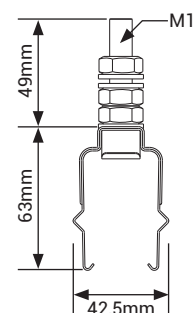

Steel Sliding Hanger



### URC-2 Hanger Bracket

Description	L (mm)	Order Code
URC-2 Hanger Bracket	750	3025382

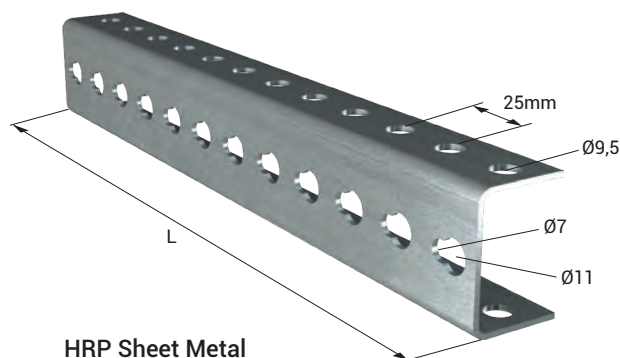
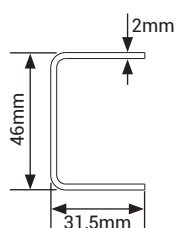

HRP Sheet Metal

### URC-2 BR Hanger Bracket Set

Description	L (mm)	Order Code
URC-2 BR Hanger Bracket Set	800	3178918

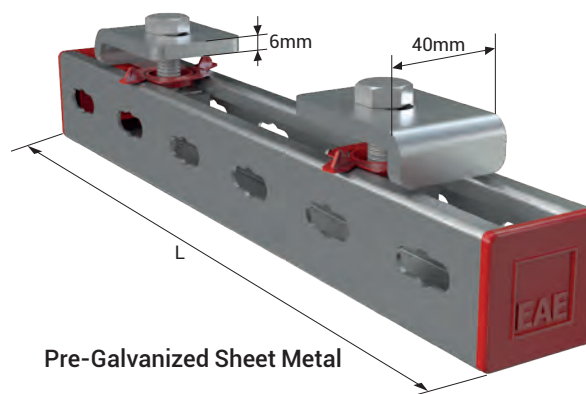
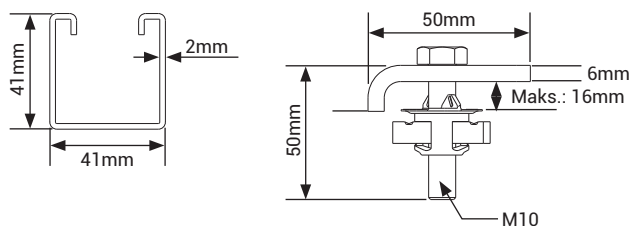

Pre-Galvanized Sheet Metal

• Please browse the MFIX catalog to see our various support solutions.

# E-LINE URC

## System Components

### URC-2 Repair Zone Module



Aluminium Conductor	C-PVC Housing		PC (Polycarbonate) Housing	
	(-40°C +55°C)		(-40°C +100°C)	
	Phase	Neutral	Phase	Neutral
URC-2 Repair Zone Module	3055997	3055998	3164919	3164920

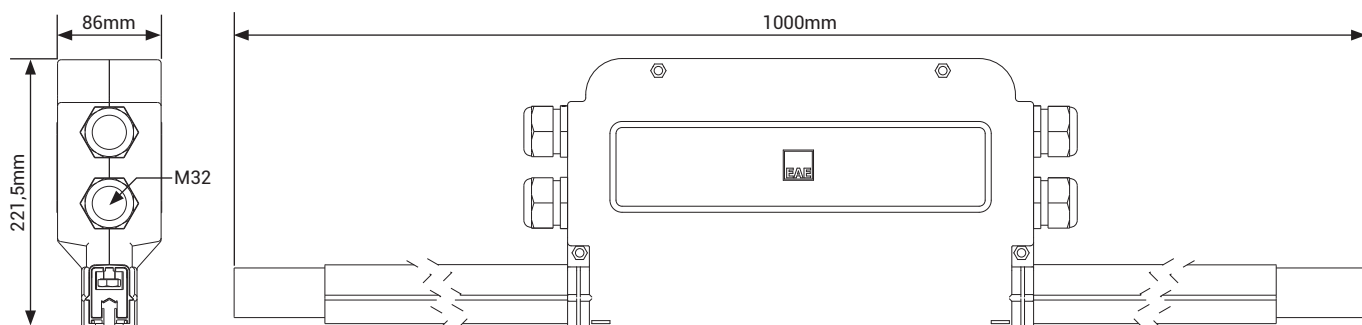
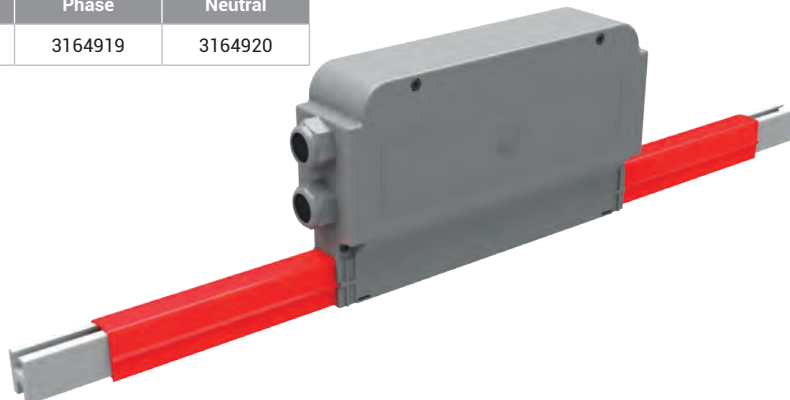

### URC-2 Expansion Module

Aluminium Conductor	C-PVC Housing		PC (Polycarbonate) Housing	
	(-40°C +55°C)		(-40°C +100°C)	
	Phase	Neutral	Phase	Neutral
URC-2 050 Expansion Module	3033983	3033984	3164925	3164926
URC-2 080 Expansion Module	3033981	3033982	3164923	3164924
URC-2 100 Expansion Module	3033979	3033980	3164921	3164922

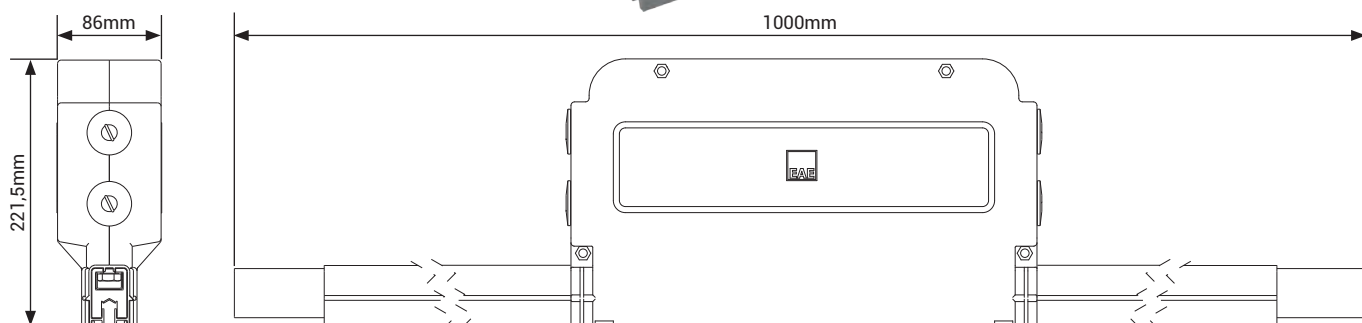
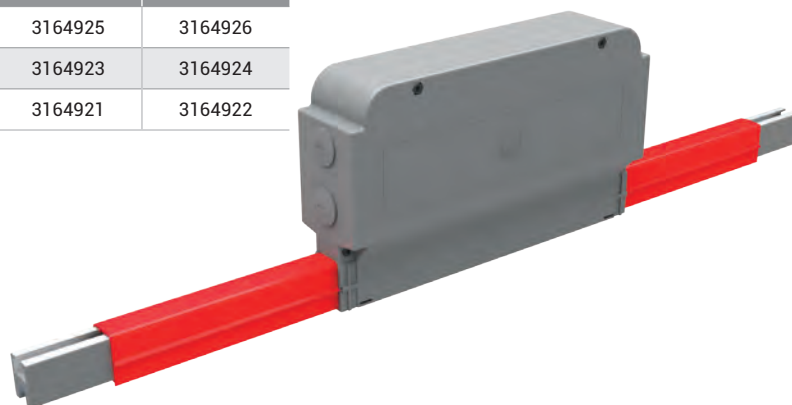

The expansion module should be used every 50 meters between the fixed points in order to protect the system from being damaged by the expansion that may occur due to heat.

The voltage drop in the busbar lines shall be inspected as per the busbar type selected according to the total current calculated based on the ambient temperature and operating period of the system. Maximum acceptable value for voltage drop is 3%.

<b>For Direct Current</b>	$\Delta U = 2 \cdot L_t \cdot I_G \cdot R$	$\Delta U =$ Voltage Drop [V]
<b>For Mono-Phase Alternative Current</b>	$\Delta U = 2 \cdot L_t \cdot I_G \cdot Z$	$I_G =$ Total Current [A]
<b>For Three-Phase Alternative Current</b>	$\Delta U = \sqrt{3} \cdot L_t \cdot I_G \cdot Z$	$R =$ Resistance of The Busbar [ $\Omega/m$ ]
		$Z =$ Impedance of The Busbar [ $\Omega/m$ ]
		$L_t =$ Calculated Hole Length [m]

**Note :** Calculation of the current drawn during first start in various motor types;  
 $I_A =$  Total current drawn in the first start of the motors [A]

For the starting current;

Three-phase asynchronous drive in direct start	$I_A = I_G \times 5 \text{ to } 6$
Slip ring rotor motor	$I_A = I_G \times 2 \text{ to } 3$
Frequency converter	$I_A = I_G \times 1,20 \text{ to } 1,50$

## Calculation of Feeding Points

When we take L as the length of the line, feeding points may be selected as shown in the diagrams below to keep the  $L_t$  voltage drop at minimum and it may be used as the hole length for the calculation of  $L_t$  voltage drop.



1 feeding point from the start  $L_t=L$

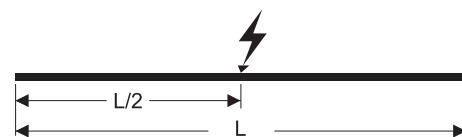

1 feeding point from the center  $L_t=L/2$



2 feeding points from the start points  $L_t=L/4$



2 feeding points  $L_t=L/6$

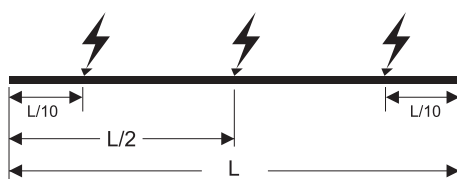

3 feeding points  $L_t=L/10$

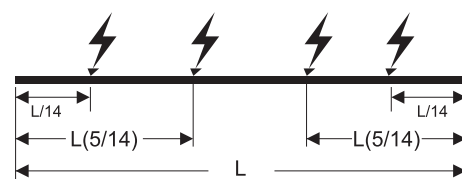

4 feeding points  $L_t=L/14$

# E-LINE URC

## Installation Manual

### General System Usage Metrics

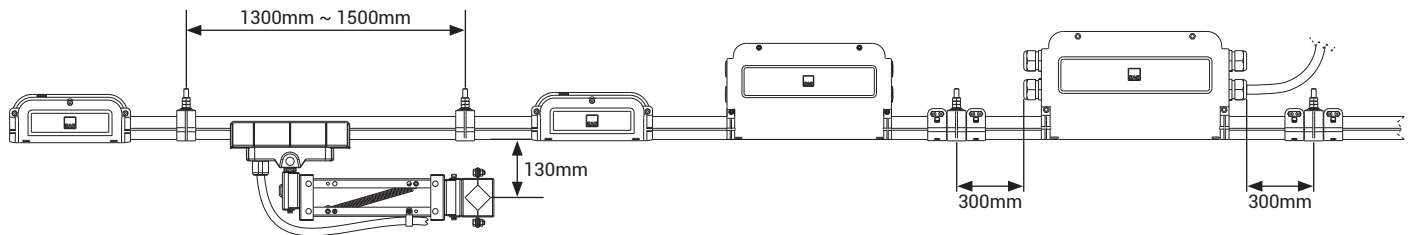

- Distance between the sliding hangers should be **1300 ~ 1500mm**.
- Distance between sliding hanger and other units (joint unit, feeder, expansion etc.) should be minimum **300mm**.

## Installation

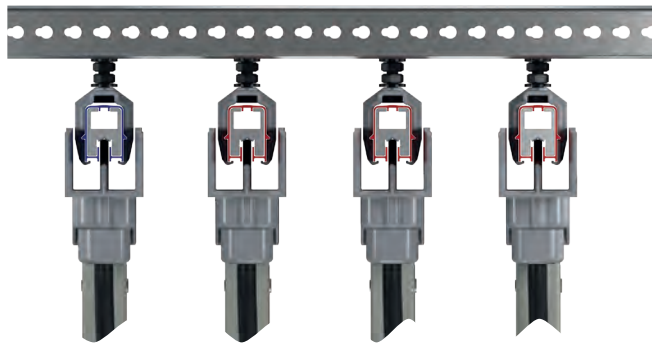

- For horizontal installation distance at least 100mm, should be between sliding hanger axes.

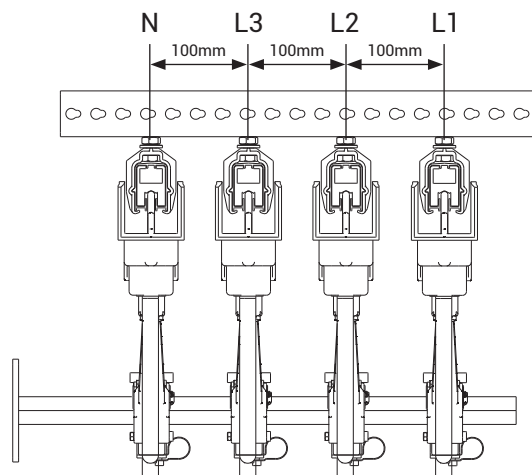

## URC-2 Joint Unit Installation Manual

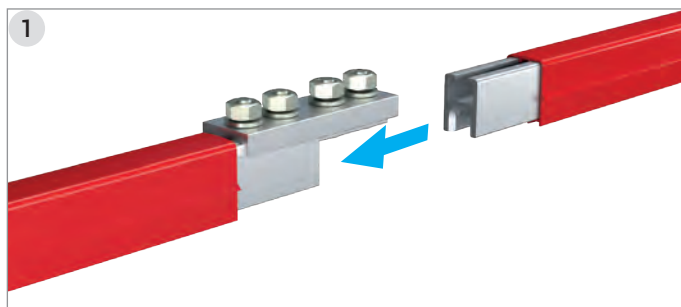

Place the joint unit between the two aluminium busbar lengths to be joined with their bolts facing upwards as shown. The notch of the joint unit should be centered at the junction of the two Busbars.

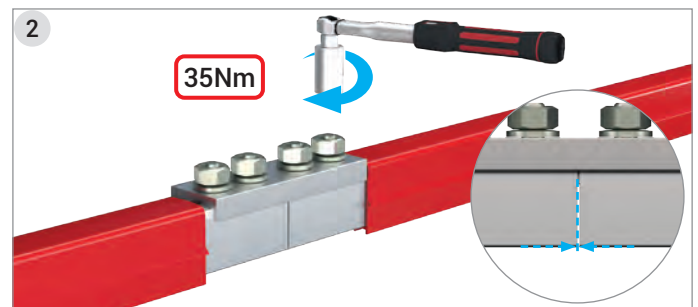

Tighten the nuts with torque wrench adjusted to 35Nm.

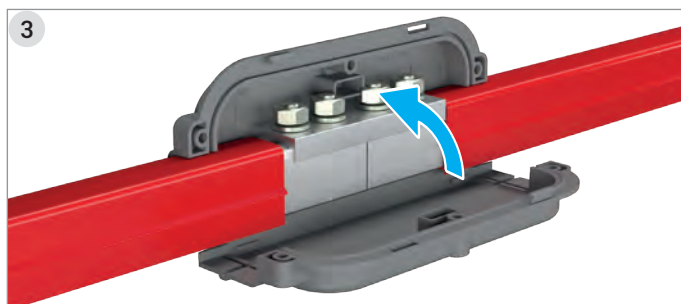

Place the joint unit covers facing each other. Put the bolts and nuts in the sockets.

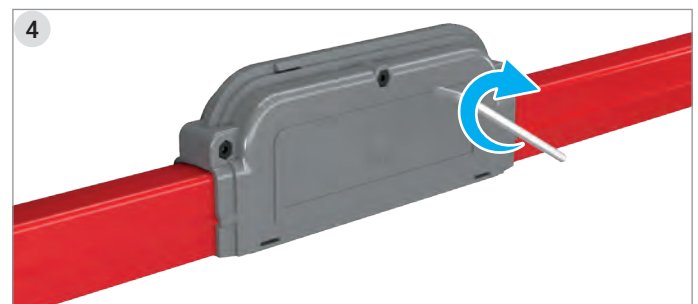

Tighten the the bolt with 5 allen wrench.

# E-LINE URC

## Installation Manual

### URC-2 Feeder Unit Installation Manual

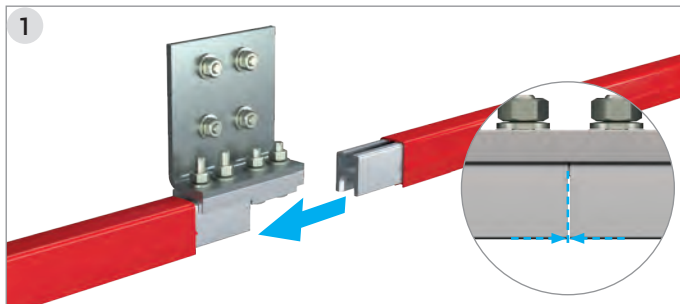

Place the joint unit between the two busbar lengths to be joined with their bolts facing upwards as shown.

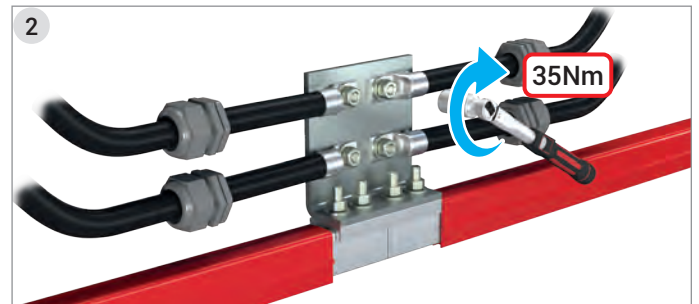

Pass the cables feeding the system through cable gland, tighten the nuts of the connecting plate with a torque wrench adjusted to 35Nm.

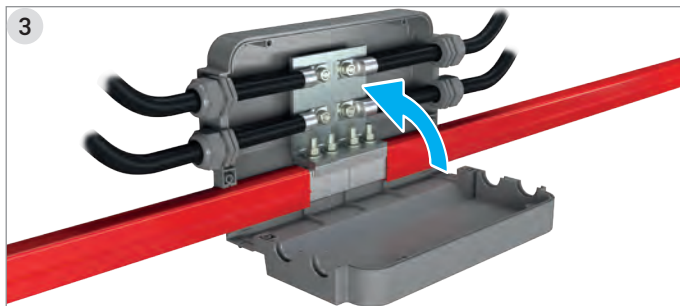

Place the feeder unit covers facing each other.

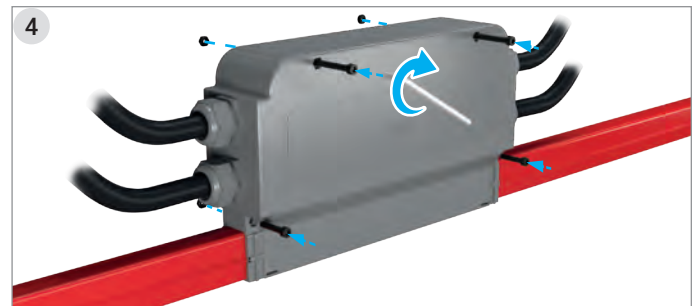

Put the bolts and nuts in the sockets. Tighten the the bolt with 5 allen wrench.

## Calculation of Feeding Points

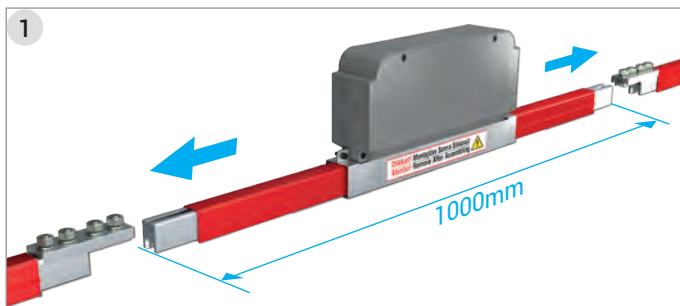

Installation of the expansion module in accordance with the joint unit installation instructions.

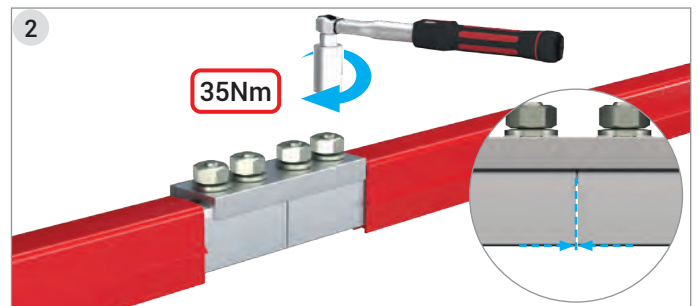

The notch of the joint unit should be centered at the junction of the two busbars. Tighten the nuts with torque wrench adjusted to 35Nm.

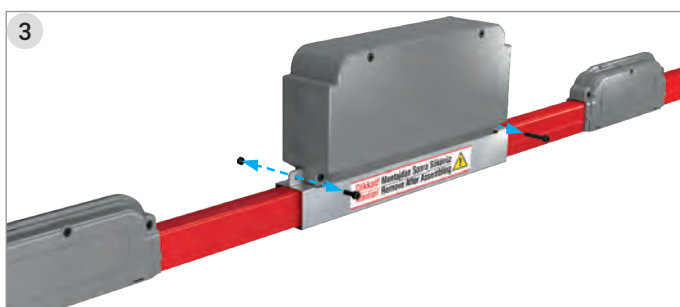

Do not open the expansion module covers. After assembly unscrew the bolts of the alignment part and remove it.

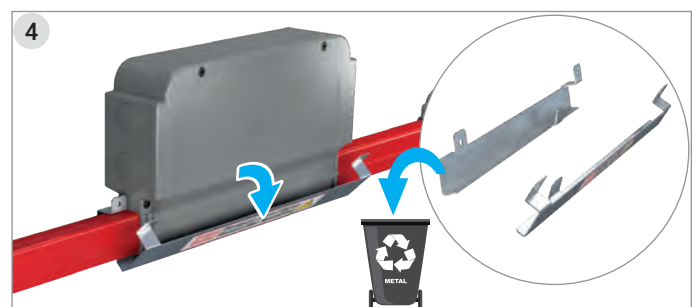

Throw the steel alignment jig into the recycling bin.

**Note:** If the alignment part is removed before assembly, the distances of the module should be adjusted as shown in the Figure 1.

# E-LINE URC

## Offer Request Form



Date :

Project Name	:	<input type="text"/>
Company	:	<input type="text"/>
Name Surname	:	<input type="text"/>
Tel	:	<input type="text"/>
E-Mail	:	<input type="text"/>
Address	:	<input type="text"/>

### General Data

Track Length	:	<input type="text"/>
Number of Cranes on Track	:	<input type="text"/>
Crane Travel Speed	:	<input type="text"/>

### Environmental Data

Operating Environment	:	<input type="checkbox"/> Indoor	<input type="checkbox"/> Outdoor
Ambient Temperature	:	<input type="text"/> °C min.	<input type="text"/> °C max.
Other Operating Conditions (Humidity, Dust, Chemical Influence, etc.)	:	<input type="text"/>	

### Electrical Data

Operating Voltage	:	<input type="text"/> Volts	<input type="checkbox"/> AC	<input type="checkbox"/> DC			
		<input type="text"/> Phases	<input type="checkbox"/> N	<input type="checkbox"/> PE			
Position and Number of Feeder	:	<input type="text"/> from End	<input type="text"/> from Middle				
Duty Cycle (%)	:	<input type="checkbox"/> 50%	<input type="checkbox"/> 60%	<input type="checkbox"/> 70%	<input type="checkbox"/> 80%	<input type="checkbox"/> 90%	<input type="checkbox"/> 100%

Motor Specifications	Crane - 1		Crane - 2		Crane - 3	
	Power (kW)	Current (A)	Power (kW)	Current (A)	Power (kW)	Current (A)
Hoist motors	<input type="text"/>	<input type="text"/>	<input type="text"/>	<input type="text"/>	<input type="text"/>	<input type="text"/>
Auxiliary motor	<input type="text"/>	<input type="text"/>	<input type="text"/>	<input type="text"/>	<input type="text"/>	<input type="text"/>
Long travel	<input type="text"/>	<input type="text"/>	<input type="text"/>	<input type="text"/>	<input type="text"/>	<input type="text"/>
Cross travel	<input type="text"/>	<input type="text"/>	<input type="text"/>	<input type="text"/>	<input type="text"/>	<input type="text"/>

### Options

Brackets Required	:	<input type="checkbox"/> Yes	<input type="checkbox"/> No
Repair Zone Required	:	<input type="checkbox"/> Yes	<input type="checkbox"/> No
		<input type="text"/> Qty	
Collector Replacement Required:		<input type="checkbox"/> Yes	<input type="checkbox"/> No
		<input type="text"/> Qty	
Descriptions	:	<input type="text"/>	

Please duplicate this page for your own use.

## CE DECLARATION OF CONFORMITY

**Product Group** E-Line Trolley Busbar Systems  
**Manufacturer** Akcaburgaz Mahallesi, 3114. Sokak,  
No:10 34522 Esenyurt-Istanbul

The objects of the declaration described below is in conformity with the relevant Cable gland harmonisation legislation. This declaration of conformity is issued under the sole responsibility of the manufacturer.

**Standard:**

**TS EN 61439-6**

Low-voltage switchgear and controlgear assemblies - Part 6: Busbar trunking systems

**CE - Directive:**

2014/35/EU "The Low Voltage Directive"

2014/30/EU "(EMC) Electromagnetic Compatibility Directive"

2011/65/EU "RoHS Directive"

**Technical Document Preparation Official:**

EAE Elektrik Asansor End. Insaat San. Tic. A.S.  
Akcaburgaz Mahallesi, 3114. Sokak, No:10 34522 Esenyurt-Istanbul

Mustafa AKÇELİK

**Date**

26.05.2026

**Document Authorized Signatory**

Elif Gamze KAYA OK  
Deputy General Manager



# SUSTAINABLE FUTURE

## Sustainability Management at EAE Elektrik



As part of our goal to support sustainable development and green transformation, measuring, evaluating, and managing all economic, environmental, and social impacts resulting from our sustainability practices is a key governance priority for EAE Elektrik. We act with great care in analyzing, monitoring, and managing the economic, environmental, and social impacts and risks that arise throughout our value chain in both our national and global operations.

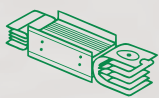

Busbar Systems

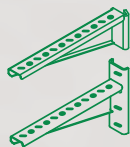

Support Systems

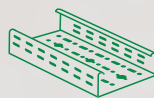

Cable Tray Systems

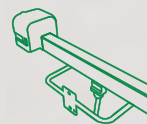

Trolley Busbar Systems



Fit-Out Solutions

*"We are working together with all our stakeholders to develop the electrical technologies that will build the future."*

You can visit our sustainability website at [sustainability.eaeelectric.com](https://sustainability.eaeelectric.com)



#FutureTogether

**EAE Elektrik**  
**Head Office**

Akcaburgaz Mahallesi,  
3114. Sokak, No: 10 34522  
Esenyurt - Istanbul - Turkiye  
Tel: +90 (212) 866 20 00  
Fax: +90 (212) 886 24 20

**EAE DL 4 Factory**  
**Busbar 2**

Organize Sanayi Bolgesi Mahallesi,  
6. Cadde, No: 14/10, 41455  
Dilovasi - Kocaeli - Turkiye  
Tel: +90 (262) 999 05 55  
Fax: +90 (262) 502 01 45



Please visit our website for the updated  
version of our catalogues.  
[www.eaeelectric.com](http://www.eaeelectric.com)



Catalogue 15 - En. / Rev. 17 1000 Pcs. 26/05/2026  
E.U.

EAE has full right to make any revisions or changes on this catalogue without any prior notice.