



# DATA CENTER SOLUTIONS

## DATA CENTER SOLUTIONS

EAE Elektrik is your reliable and innovative manufacturer worldwide offering Busbar, Rack Cabinet, Cable Tray and Support Systems to serve the critical Data Center infrastructure with peace of mind.



### CUSTOMER DRIVEN DESIGN

The EAE product family has been designed and manufactured to address the needs of end users. At all design steps, customer's feedback has been considered which guides our design engineers to end-up with more user friendly, modular and wide range products.



### LEAN PRODUCTION

To add value for the customers, increase productivity and quality, to manage competition, we strongly adopt "Lean Production". It is an important tool that helps EAE to act fast, create wide product portfolio and reduce manufacturing costs.



### INNOVATIVE APPROACH

The EAE product family provides innovative solutions such as Seismic Rack Cabinets and Seismic Support Systems, Particular Aisle and Containment for Cooling and In-aisle Lighting with continuous R&D studies to increase Energy Efficiency and maximize Uptime.

## Energy Efficiency

Availability

Scalability

Security



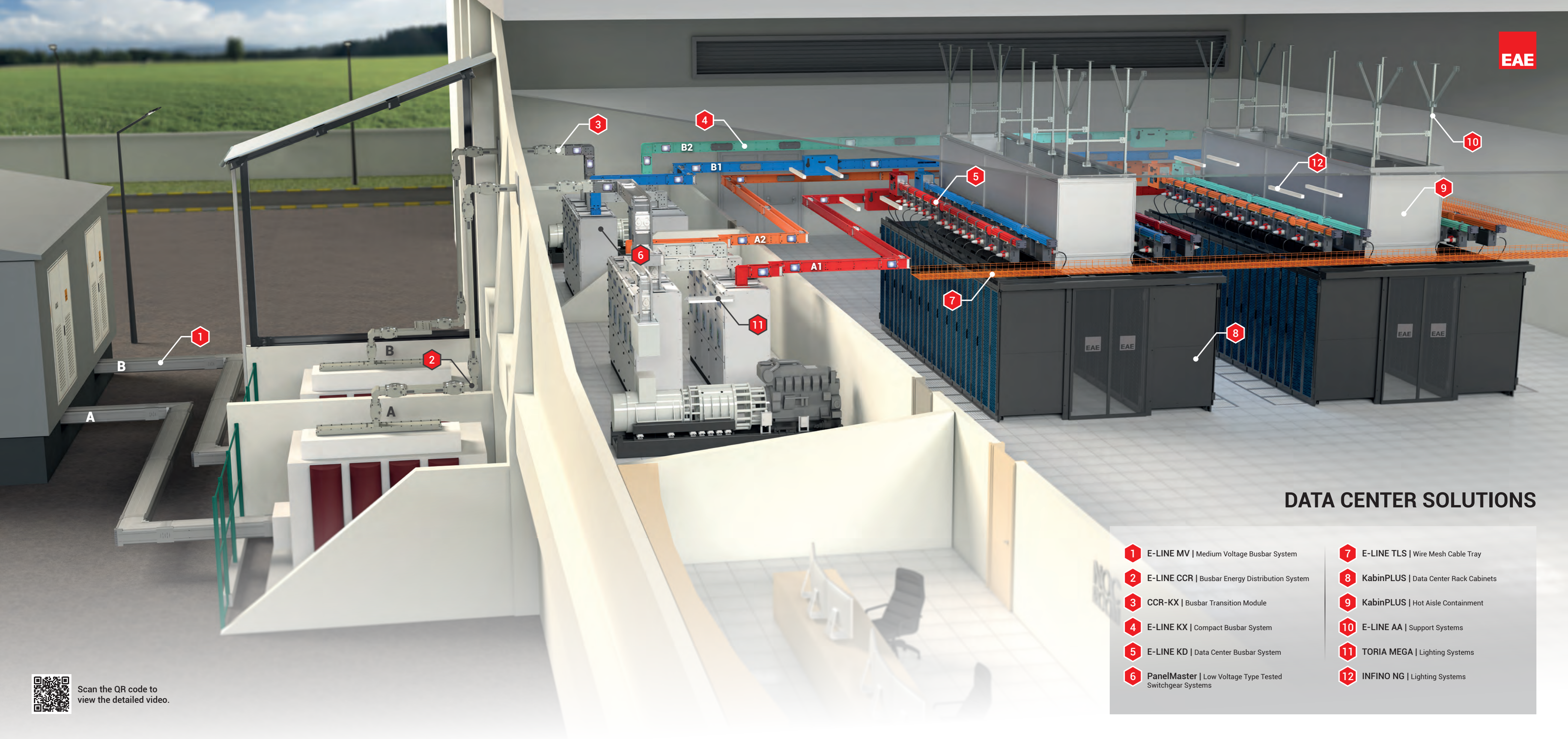

## DATA CENTER SOLUTIONS

- 1 E-LINE MV | Medium Voltage Busbar System
- 2 E-LINE CCR | Busbar Energy Distribution System
- 3 CCR-KX | Busbar Transition Module
- 4 E-LINE KX | Compact Busbar System
- 5 E-LINE KD | Data Center Busbar System
- 6 PanelMaster | Low Voltage Type Tested Switchgear Systems
- 7 E-LINE TLS | Wire Mesh Cable Tray
- 8 KabinPLUS | Data Center Rack Cabinets
- 9 KabinPLUS | Hot Aisle Containment
- 10 E-LINE AA | Support Systems
- 11 TORIA MEGA | Lighting Systems
- 12 INFINO NG | Lighting Systems



Scan the QR code to view the detailed video.



## Since 1973

EAE Group of Companies started its journey in the electrical sector in 1973 with the establishment of EAE Elektrik. Since its founding, EAE has grown rapidly, expanding its production and areas of operation by incorporating EAE Lighting in 1983, EAE Machinery in 1996, EAE Electrotechnics in 2004, and EAE Technology in 2009.

EAE carries out its production activities in accordance with ISO 9001 Quality Management, ISO 14001 Environmental Management, ISO 14064-1 Greenhouse Gas Management System, ISO 45001 Occupational Health and Safety Management, ISO 10002 Customer Satisfaction Management, ISO 50001 Energy Management System, and ISO 27001 Information Security Management System standards.



**50+**  
Years Experience



**8**  
Active Factories



**370.000m<sup>2</sup>**  
Enclosed Space



**3**  
R&D Centers



**150+**  
Countries Exported To

### Supervision Services

Experienced EAE teams are available for measurements, installation and testing services on-site



### Short Response & Delivery Time

Extensive manufacturing capacity to provide order deliveries within 3-4 weeks' time (Ex-Works incoterms).  
Emergency manufacturing team can produce in 48 hours any urgent product requirement due to site hold or damaged items during installation



### Busbar Software, 3D and Revit Modelling

Easy-use software for practical and fast project design providing precise material lists. EAE Busbar products are available in Revit and Aveva libraries.



### Pre-Sales Customer Services

Comprehensive technical product consultancy for the tailored customer solution and technical design services free of charge



### ENERGY EFFICIENCY;

The accelerated rise of energy consumption in data centers and increasing global energy costs make the energy efficiency the permanent hot topic in the data center industry. Due to its big impact on energy efficiency, the heat sources in the IT Power Infrastructure shall be considered within the scope of an "Energy Optimization Program" leading to reduced power loss and naturally less heat dissipation. In addition to that, the cooling methods shall be considered and implemented carefully aiming to completely isolate cold cooling air and hot exhaust air with a correct airflow management by means of containment solutions.

### AVAILABILITY;

The Uptime Institute defines Tier classifications for the proper design, build and operation of data centers. The availability of the data center for the active hardware (servers & switches) and its related power, cooling and digital connectivity infrastructure shall always be maintained during operation, maintenance and the upgrade processes. To ensure this, the IT Power Infrastructure shall provide High Short Circuit, High Fire Resistance, Hot-Swap Operations and Physical Durability as well as Busbar Tap-Off points Flexibility while The IT Passive Digital Infrastructure of Rack Cabinets and High Density Cable Tray Systems shall ensure end-to-end sustainability.

### SCALABILITY;

The accelerated rise of the volume of data due to Colocation & Cloud Computing and also the recent trends such as IoT and new approaches in social media is the reason of the Data Center spaces to be LIVE environments with a lots of moves, adds and changes (MACs), bringing up the Scalability issue as one of the important challenges. The data center design approach shall consider the overall capacity increase for the first day and future upgrades with flexible implementations. The IT Power and Passive Digital Infrastructure with High Modularity, Flexible Project Management and Expansion, Time Saving Fast Installations, Free Standing Aisle Containments which are expandable and adaptable for standard and non-standard Rack Cabinets together with Wire Mesh Cable Trays ensure the fulfillment of this objective.

### SECURITY;

Rack, corridor, room, zone and building based physical and environmental security against theft, fire, flood and earthquake shall be maintained and supervised in data center environments. The Colocation & Cloud Computing business models demand customer based physical access to their particular racks and zones while the service provider shall keep the overall operability of the critical IT infrastructure against intrusion. To secure the operational sustainability the IT Power and Digital Infrastructure particular solutions such as Sprinkler Proof Busbars, Tap-Off Boxes with Locking Mechanism and Dual Door (for temperature measurement under load), Seismic Restraint Support Systems, High Fire Resistance, Tin Whisker Protection and Seismic Rack Cabinets with Seismic Stand are from great importance. Customer based physical access against intrusion, mechanical and electro-mechanical locking, keypad access, proximity card access, finger print, eye retina or hand geometry biometric access solutions shall be among the choices of the end-customers.

# DATA CENTER SOLUTIONS

## Challenges

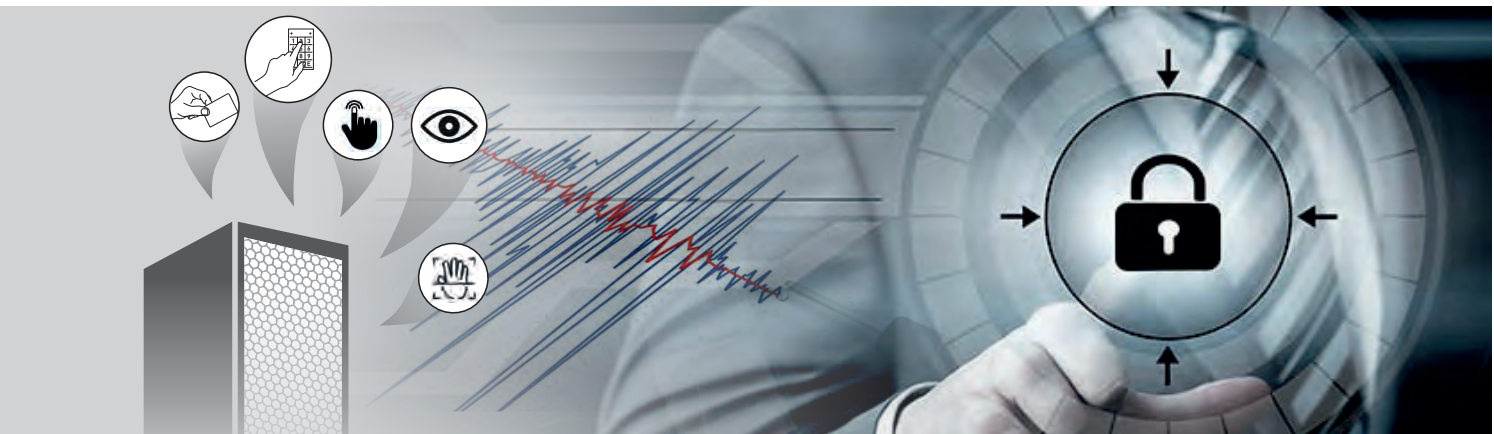
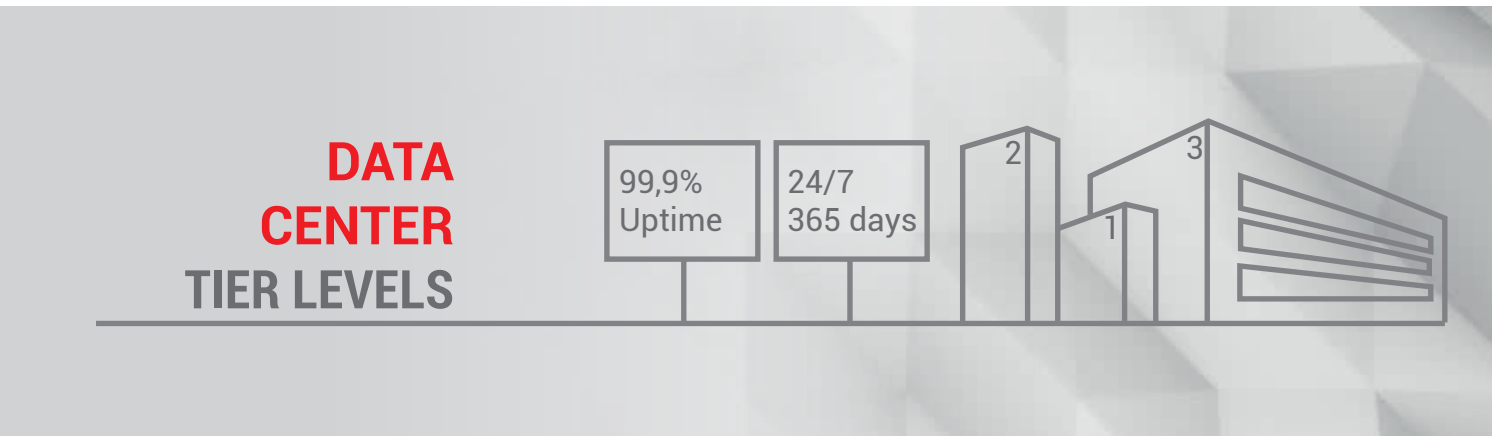

# DATA CENTER SOLUTIONS

## Busbar Power Distribution Systems

E-LINE KD / Data Center Busbar Distribution Systems 160A...1000A



### Overview

To power the mission critical IT infrastructures on the Data Rack Cabinets, EAE offers a highly flexible and reliable Busbar System to meet the "Scalability" challenge in the Data Centers finding the way to Moves, Adds and Changes (MACs).

### Features

- Plug-in-play anywhere along the bar
- Protected Tap-off contacts
- Aluminium or copper conductors
- 4,5 or 6 conductors
- Tin plated aluminium or copper conductors
- Safe alignment mechanism ensures correct installation and operation
- Special interlock mechanism enabling to carry the weight of the plug-in box and cables by the busbar housing
- IP 23D protection level

### Applications

- Data Centers - White Space
- Data Centers - High Density Distribution Points and Mid-Range Power Distribution Areas with "Infinite Flexibility"
- Other - Medium sized buildings and industrial facilities

To power the mission critical IT infrastructures, EAE offers a highly flexible Busbar Systems for reliable and energy efficient operations in your Healthcare System's Data Centers.

The E-Line KD Busbar system from EAE is designed for safe, flexible, and efficient power distribution in rack-type data center applications. It supports currents from 160 A up to 1000 A and allows easy installation of plug-in tap-off boxes anywhere along its housing, enabling modular and scalable power delivery. The system features aluminum or copper conductors and a durable monoblock joint structure for secure connections. Its IP23D-rated enclosure protects against solid objects larger than 12.5 mm, tool or wire access, and water spray up to 60°, ensuring safety in indoor environments. It offers configurations with 4, 5, or 6 conductors, adapting to different power distribution needs. Tap-off boxes include internal separation and locking mechanisms for added operational security. Energy monitoring is also supported, and brand-independent energy monitoring systems can be integrated into the tap-off boxes, making the system well-suited for scalable, high-efficiency data center infrastructures.

## DATA TAP-OFF Boxes Upto 125A;



KD Plug-in 125A and 80A Tap-Off Boxes are made of aluminum case with Safe Locking Mechanism enables Customization with vendor neutral components for different setups of MCB, SPD, RCCB, Power Meters Energy Analyzers and Current Transformers etc.

# DATA CENTER SOLUTIONS

## Busbar Power Distribution Systems

E-LINE KO-II / Busbar Power Distribution System 160A...800A



### Overview

The E-Line KO Series is a medium power range busbar system providing a highly flexible solution for the white space of the data centers to distribute power and feed the Rack Cabinets with the required power budgets.

### Features

- Modular structure
- Plug-in tap off points at every 25 cm.
- Aluminium or copper conductors
- 4, 4,5 or 5 conductors
- Tin plated conductors with tin whisker free contacts
- Dust cover on outlet points
- Halogen free material
- IP 55 protection class
- Single shear head bolt joint
- Compact Tap-off Boxes up to 80A
- Metal Tap-Off Boxes up to 400A

### Applications

- Data Centers - White Space Area
- Data Centers - Medium Range Power Distribution Areas with High Density Tap-Off Points
- Other - Medium-sized buildings or industrial facilities

Thanks to their design, E-Line KO busbars are able to accommodate high density tap-off points thus various tap-off boxes can be deployed at every 50 cm. along the both sides of the busbar resulting with a tap-off point at every 25 cm. distance. The E-Line KO Busbars can be used in horizontal or vertical applications. Versatile Tap off box solutions comprising metal and plastic boxes for small currents with particular locking mechanisms, can easily be customized and equipped with different setups of MCBs, SPDs, RCCBs, Power Meters, Energy Analyzers and Current Transformers for electrical protection, energy monitoring and management.

## DATA TAP-OFF Boxes; upto 400A

To feed the Rack Cabinets with the required power budgets and monitor the energy consumption. EAE offers a wide range Tap- Off Boxes composed of metal and plastic cases.



# DATA CENTER SOLUTIONS

## Busbar Power Distribution Systems

E-LINE MK / Busbar Power Distribution System 100A-160A-225A-250A



### Overview

The E-Line MK Series small power range busbar systems are flexible and cost-effective solutions for the distribution of electrical power in data center white spaces for lower energy requirements.

### Features

- Modular structure
- Plug-in tap off outlets at every 25 cm. on both side
- Tin plated aluminium or copper conductors with tin whisker free contacts
- 4 or 5 conductors
- Hinged and lockable dust cover on outlet points
- Halogen free material
- Installation without using a torque wrench (shearhead bolts)
- IP 55 protection class
- Compact Tap-off Boxes up to 80A

### Applications

- Data Centers - White Space Area
- Data Centers - Low Range Power Distribution Areas with High Density Tap-Off Points
- Other - Small-sized buildings or industrial facilities

Tap-off points at every 50 cm. on both sides can be deployed resulting with a tap-off point in each 25 cm. distance. The E-Line MK Busbars can be used in horizontal or vertical applications. Versatile Tap off box solutions comprising metal and plastic boxes rated up to 80A can easily be customized for electrical protection and energy metering.

## DATA TAP-OFF Boxes; upto 400A

Customized tap-off boxes provide an independent setup for choosing a variety of electrical equipment to be installed regardless of the brand. Energy Metering over RJ-45 connections using structured cabling is one of the value-added features of the EAE Tap-Off boxes for the real-time monitoring of energy consumption and other critical power parameters in your data centers to monitor and drive your IT infrastructure efficiently.

### Features

- Plastic or Metal
- IP 55 protection class
- Compact Tap-off Boxes up to 80A
- Aluminium Tap-Off Boxes up to 125A
- Sheet metal Tap-Off Boxes up to 400A
- RJ-45 Connectivity
- Energy Monitoring and Management Customization with
  - Main/Molded Case/Residual Circuit Breakers
  - NH Fuses
  - Surge Protection Devices
  - Power Meters with Current Transformers
  - Energy Analyzers

# DATA CENTER SOLUTIONS

## Busbar Power Distribution Systems

E-LINE KX / Compact Busbar Power Distribution System 400A...6300A

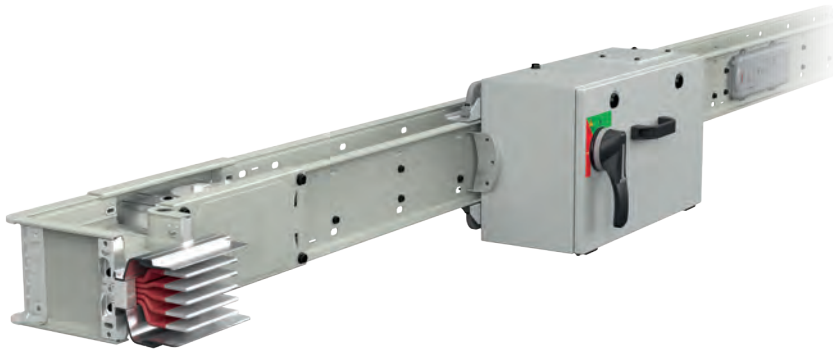

### Overview

The E-Line KX Series is the ultimate solution for high power range compact busbar systems to distribute power from the main transformer stations, generator sets and various high power sources through main distribution lines to the LV Switchgear in the data center power infrastructure.

### Features

- Modular structure
- Plug-in tap off points at every 60 cm.
- Aluminium or copper conductors
- 3; 4; 4,5; 5 or 6 conductors
- Tin or silver plated conductors with tin whisker free contacts
- Epoxy Insulation
- Dust cover on outlet points
- Halogen free material
- IP55, IP65, IP67 protection class
- Seismic compliance
- Single bolt joint
- Sheet metal Tap-Off Boxes up to 630A (Plug-in) 1200A (Bolt-On)
- GreenGuard Gold and CPR B1ca, s1, d0 certifications

### Applications

- Data Centers - White Space Area
- Data Centers - High to Medium Range Power Distribution Areas
- Other - High to Medium sized buildings or industrial facilities

With ratings from 400A to 6300A composed of high conductivity copper and aluminum conductors, the sandwich construction combines insulated conductors in an aluminum housing. Due to its compact design, the EAE E-Line KX Series Busbar System can also be utilized for the data center white space power distribution to leverage the space utilization and heat dissipation. The wide range Tap-Off box choices with customization also applies to the EAE E-Line KX Series.

## Fire Certificate

### KX Series Busbar

IEC 60331-1 and IEC 60331-21; **1000 °C - 3 Hours**  
IEC 60331-1; 830 °C – 3 Hours  
BS 6387; 950 °C – 3 Hours  
BS 8491; 830 °C, 120 minutes + Pressurized Water + Mechanical Impact

### Plug-in Tap Off Box

IEC 60331-1; **830 °C – 3 Hours**,  
Magnetic MCCB  
IEC 60331-1; 830 °C – 3 Hours,  
NH Circuit Breakers



# DATA CENTER SOLUTIONS

## Busbar Power Distribution Systems

E-LINE CCR / Compact Outdoor Busbar Power Distribution System 600A...6300A



### Overview

The E-Line CCR Series is a specific solution for outdoor high power range compact busbar systems to distribute power from the main transformer stations, from generator sets and various high power sources in outdoor environments for the data center power infrastructure.

### Features

- Protection degree IP68
- Protects against corrosion
- Protects against chemicals
- Resist insects and rodents
- Suitable for tropical climates
- Resistant to fire propagation
- Electrical continuity during fire
- Protects against chimney effects
- High mechanical strength
- Single bolt joint
- Low voltage drop
- High short circuit withstand
- Suitable to connect with E-Line KX busway systems

### Applications

- Data Centers - High Range Outdoor Power Distribution Areas
- Other - Big Scale buildings or industrial facilities
- Outdoor Power Distribution

### Advantages

- Lighter
- Easier mechanical support
- Reusable
- Quicker installation time
- Paint options (Special RAL Codes)

With ratings from 600A to 6300A, composed of high conductivity copper or aluminum conductors, the body of the E-Line CCR busbar is formed using DURACOMP, a composite material of epoxy resin and pure silicon protection, inserted into an Aluminium housing to ensure IP68 ratings against arduous environments with high fault level endurance, good fire ratings and resistance to moisture.

### EX - Protected

ATEX as per EN 60079-0:2009,  
EN 60079-18:2009, EN60079-31:2009

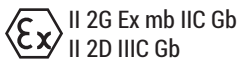

IP55  
E-LINE KX  
400A...6300A

IP68  
E-LINE CCR  
600A...6300A

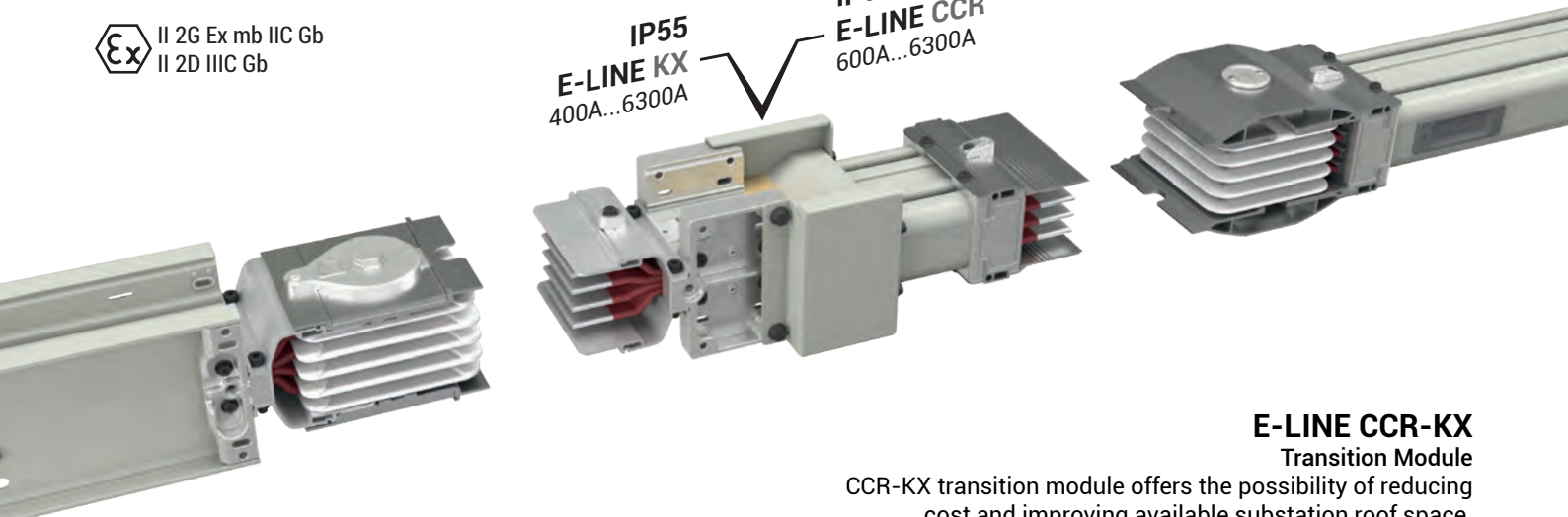

### E-LINE CCR-KX Transition Module

CCR-KX transition module offers the possibility of reducing cost and improving available substation roof space.

# DATA CENTER SOLUTIONS

## Busbar Power Distribution Systems

E-LINE MV / Medium Voltage Busbar System 12kV/17,5kV 950A...5000A



### Overview

The E-Line MV Series Busbar Systems, as the newest addition to the busbar product range, is offered with 12 kV and 17,5 kV variants. It offers safe and efficient power transmission. MV CR is manufactured in a single body with Cu conductors embedded in DURACOMP insulation which is a composite material of epoxy and pure silicon.

### Features

- Products tested in accordance with the international standards
- Outdoor IP 68 level protection
- Corrosion-resistant
- Chemical-resistant
- Pest-resistant
- Usable in tropical environments
- High mechanical strength
- Without stack effect
- Highly resistant to short circuit
- Ensures less voltage drop in comparison with cabled systems
- UV-resistant
- No requirement for maintenance
- High short circuit resistance due to compact structure
- Special design to occupy minimum space based on the running amperage rank

### Applications

- Outdoors
- Industrial buildings
- Petrochemical Industry
- Areas with flood risk
- Oil and natural gas Industry
- Power Generation Industry
- Data centers

## Current Ratings

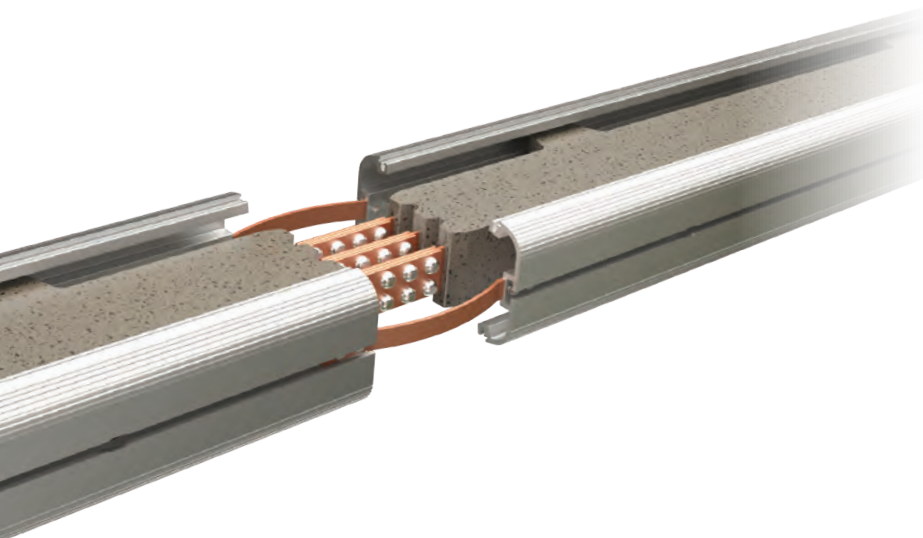

### For 12kV Copper Conductors

950A / 1150A / 1350A / 1650A / 2250A / 2750A

### For 17,5kV Copper Conductors

1800A / 2100A / 3200A / 4000A / 5000A

# DATA CENTER SOLUTIONS

## Support Systems

E-LINE A-A, BR, SEISMIC / Heavy Duty and Seismic Support Systems

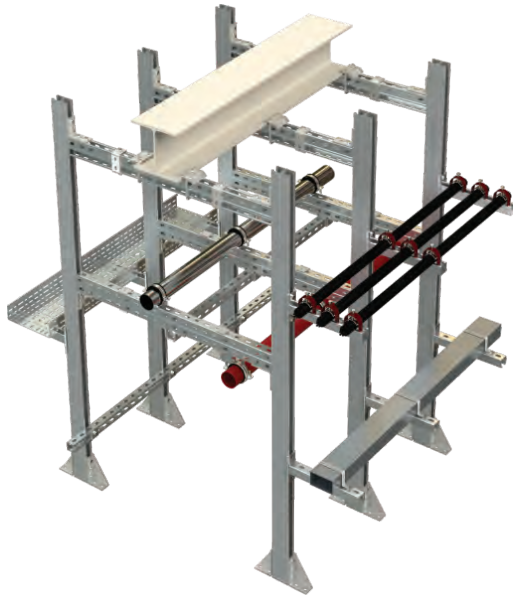

### Overview

For the cable trays, cable ladders and seismic restraint solutions of electrical and mechanical equipments, E-Line BR, E-Line A-A and E-Line Seismic support systems provide a sustainable solution for standard and heavy duty applications.

To ensure corrosion resistance and minimize the tin whisker problems, the support systems are manufactured as pregalvanized and hot dip galvanized with electrogalvanized and/or painted accessories

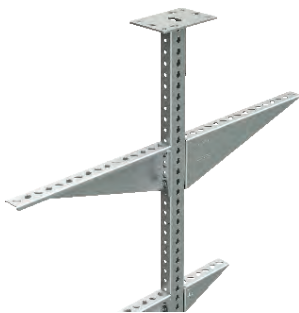

### A-A

**Hot Dip Galvanized (TS EN ISO 1461), Fire Resistant (E30-E90)**

E-Line A-A series of support systems are designed for heavy duty loads.

The A-A series can be produced from 2.0mm upto 4 mm. as hot dip galvanized. With its special coating it can withstand to 400 hours salt test and it is fire resistant.

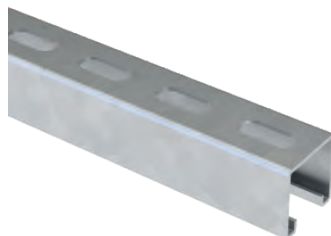

### BINRAK CHANNEL (41x41mm.)

**Pregalvanized (TS EN 10346 - TS EN 10143) and Hot Dip Galvanized (TS EN ISO 1461)**

E-Line BINRAK series are a support system especially designed for heavy duty loads.

The BINRAK series can be produced with 2.0mm and 2.5mm thickness as pregalvanized and hot dip galvanized



### SEISMIC

**Hot Dip Galvanized (TS EN ISO 1461)**

E-Line Seismic bracing assembly systems are designed to secure the support systems sustainability against seismic waves with lateral and longitudinal applications withstanding the push and pulling forces. The assemblies are produced as hot dip galvanized with electrogalvanized accessories.

# DATA CENTER SOLUTIONS

## Cable Tray Systems

### E-LINE TLS / Wire Mesh Cable Trays

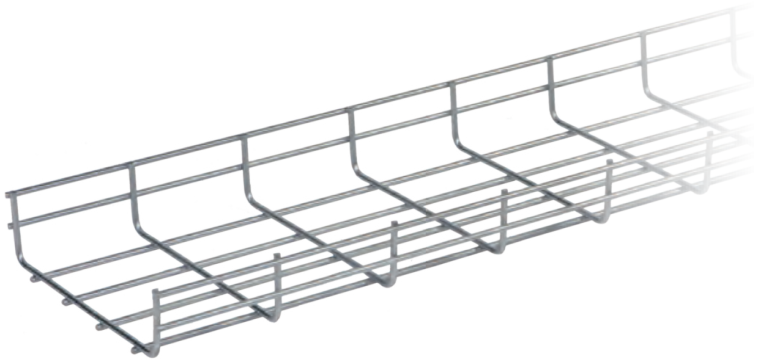

#### Overview

E-Line TLS Series wire mesh cable trays allow high density cabling with a flexibility for Moves-Adds-Changes in the data center environments.

#### Features

- Wires of 4-5 mm. of diameter to form the cable tray
- In 3000 mm. standard lengths
- Produced as electrogalvanized, stainless steel and also as painted
- H35, H55, H75, H85 and H100 mm.
- W50.....W600 mm.
- Flexible application with feature rich accessories
- Fire resistant

#### Applications

- Data Centers - White Space Overhead Data Cabling
- Data Centers - White Space Raised Floor applications
- Other - Food Industry, Oil&Gas Industry

Stainless steel or electro-galvanized wire mesh tray with painted option helps to eliminate the tin whisker problems and provides color coding in the cable pathways. The cage structure and feature rich accessories of the E-line TLS cable trays makes it simple for modular expansion and easy access in-between the cable pathways.

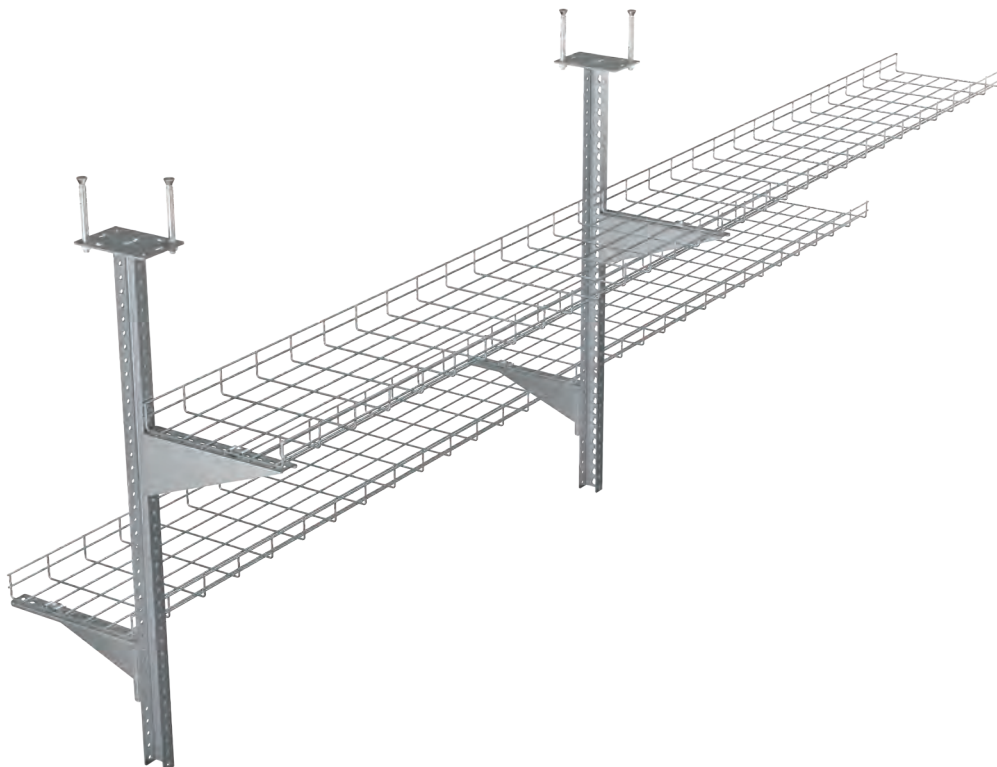

# DATA CENTER SOLUTIONS

## Cable Tray Systems

### E-LINE UKFG / Pregalvanized Cable Tray Systems



#### Overview

E-Line UKFG Series cable trays are aimed to build-up a general purpose cabling infrastructure in data center environments.

#### Features

- Heavy duty type
- 40/50/60/75/100mm heights
- 100/200/300/400/500/600mm widths
- 100/200/300mm widths 0,7mm and 400/500/600mm widths 0,9mm thicknesses
- Thanks to special forming of the edges of the tray lengths, it can bear the load equal to the products with standard thickness
- Thanks to its snap on system, easily mounted without the need for additional elements
- Wide range of accessories
- Fire resistance certificates (E30-E60-E90)

#### Applications

- Parking areas
- Hotels, housing
- Factory and industrial plants
- Food processing plants

E-LINE UKFG systems can be connected with a bolt without the need for any an additional equipment thanks to its snap on system on the edges. It offers the greatest savings with minimum installation time thanks to its minimum thickness and minimum costs and simple installation on site.

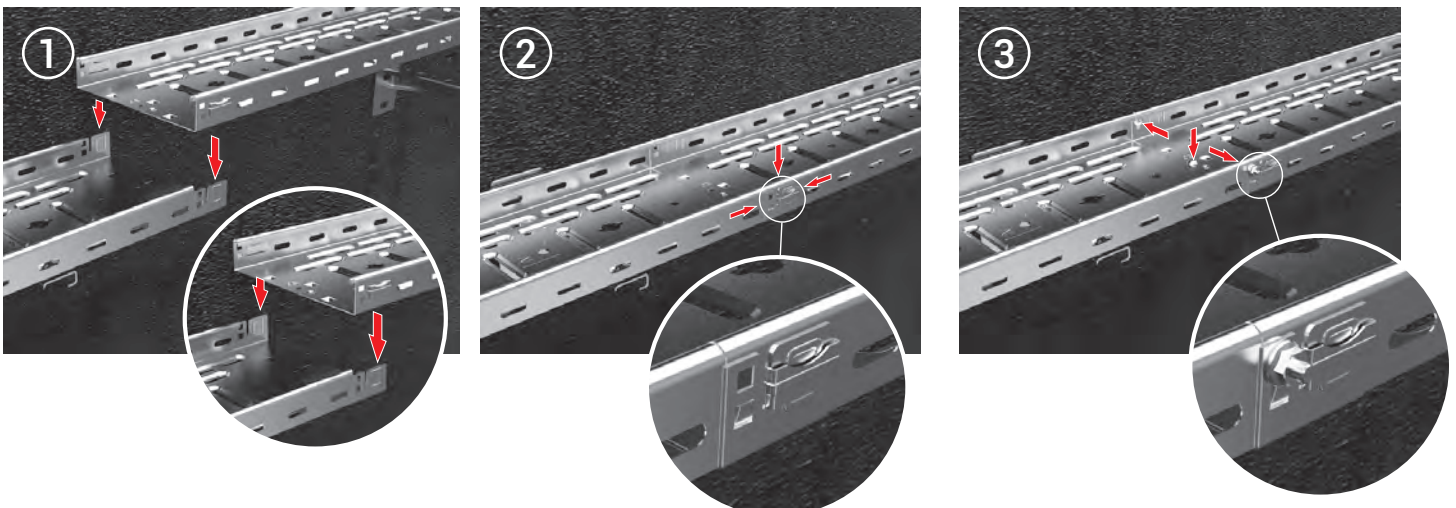

# DATA CENTER SOLUTIONS

## Cable Tray Systems

### E-LINE TLS-G / Wire Mesh Cable Trays

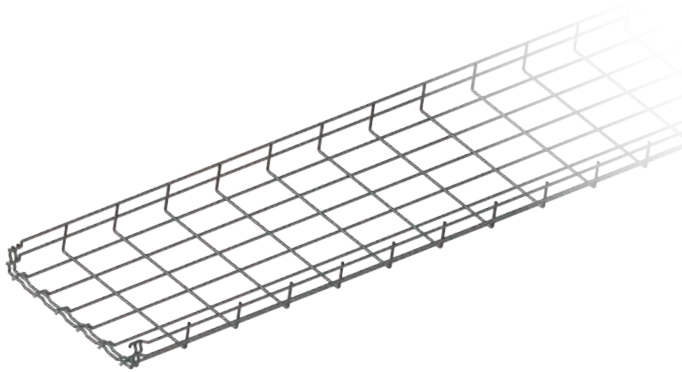

#### Features

- Wires of 4-5 mm. of diameter to form the cable tray
- In 3000 mm standard lengths
- Produced as electrogalvanized and stainless steel.
- 055 mm height.
- 100.....600 mm width.
- Flexible application with feature rich accessories

#### Overview

The TLS-G wire cable trays, manufactured in electro-galvanized and stainless steel materials, are designed to provide robust and reliable cable management solutions.

#### Applications

- Data centers
- Industrial facilities
- Commercial buildings
- Infrastructure projects
- Networking and telecommunications setups
- Power plants and utilities

Featuring a modular design and a convenient “click” connection system for seamless installation, along with compatibility with a wide range of accessories, these trays are an ideal choice for data centers, ensuring optimal performance and reliability in their environment.

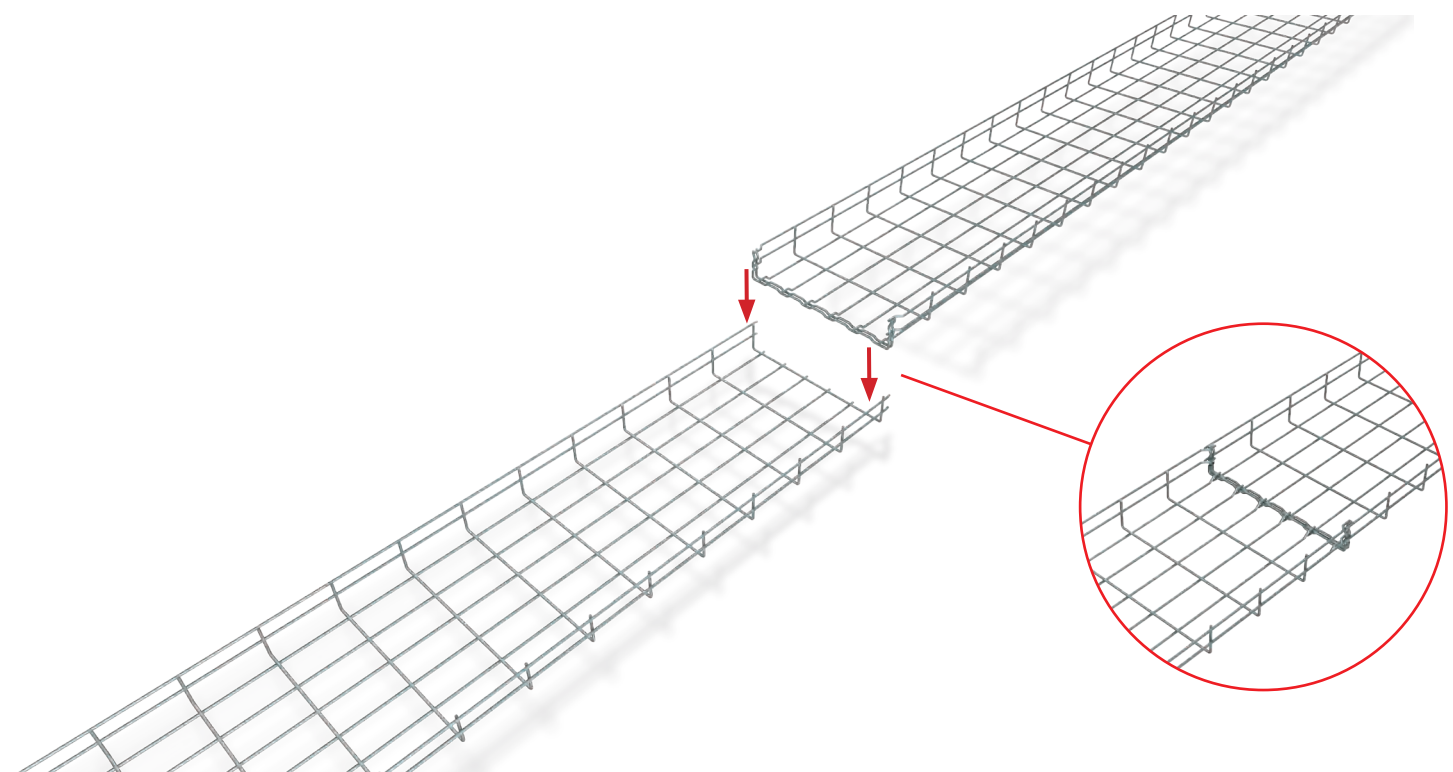

# DATA CENTER SOLUTIONS

## Rack Cabinet Systems

### General Features



#### Configuration Flexibility

- Wide range of choices in dimensions and configurations
- Assembled delivery of selected configuration
- Designed to be used as a single unit or bayed in a row
- Wide range of interior mounting, cabling and airflow management accessories are available

#### Robust Framework

Rigid framework made of steel with 1500 kg static and dynamic loading capacity -dynamic loading with heavy duty castor sets

#### High Corrosion Resistance

All parts made of pre-galvanised sheet steel or have protective coating. In addition electrostatic powder painted for superior corrosion protection.

#### Standart Colours

RAL 9003 White  
RAL 9005 Black  
Please contact for other alternatives

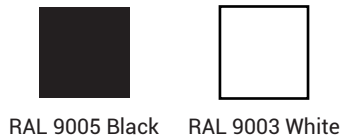

#### Grounding

All doors, covers and internal parts are grounded with the body. The door grounding conductor is in a socket structure. The grounding terminal positioned on the frame is designed as a connection point to the common grounding network.

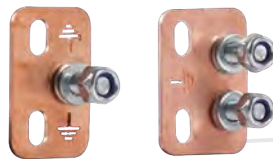

#### Cabinet Baying Kit

- Baying brackets made of 3 mm steel
- 4 pieces of baying brackets per upright pair
- It is not necessary to remove the doors during the cabinet baying
- Baying brackets placed below the door plane - invisible when door closed
- The baying kit does not interfere with installation space in the cabinet interior
- Cabinets can be bayed with or without side panel fitted on

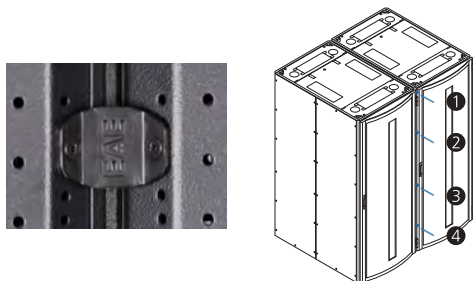

#### True Dimensions

- Doors are excluded in frame depth dimension
- Access to adjacent raised floor tiles directly in front or behind the cabinet is not blocked



### KD Series



#### Levelling Feet

- Levelling feet allows adjustment on uneven floors
- Full metal design; no plastic part
- Loading capacity 1500 kg / 4 feet
- Adjusting range between 85 mm and 100 mm and +/- 15 degree
- Possibility of adjustment from inside the cabinet when external access to the feet is blocked by airflow management accessories
- Levelling feet is adjustable from outside and inside the cabinet easily at each corner

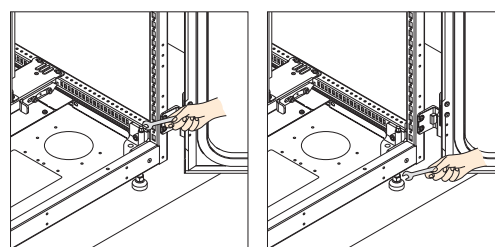

Adjustment from inside

Adjustment from outside

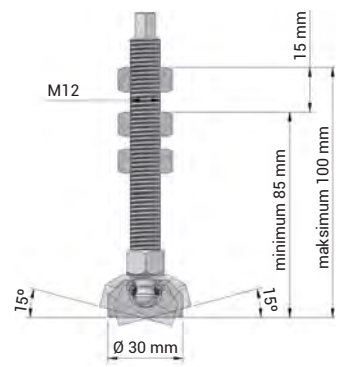

Full-metal design

### KabinPLUS



#### 19 Inch Mounting Rails

- Compatible with EN 60297-3-100 ve EIA-310E
- 4 pieces of mounting rails in all configurations
- Dual welded design with 2 mm +1,5 mm steel rails
- Square mounting holes for M6 cage nuts
- 1500 kg load capacity with four rails
- Additional 12U Zero-U mounting area option in 800 mm wide cabinets

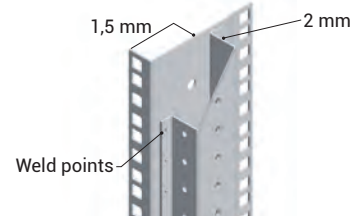

- Design with top and bottom support rails in width axis for fixing mounting rails eliminate fixing at mid-height to the frame. More space is provided for cabling and air flow management accessories
- Mounting rails are in same colour with the cabinet
- Threaded bolts and cage nuts used for device mounting and rail fixing ensure low resistant grounding

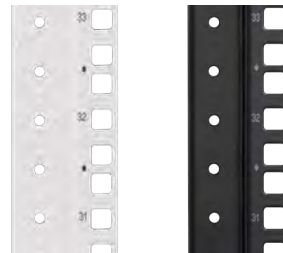

Rack unit markings both on front and rear mounting rails - white marking on black paint / black marking on white paint

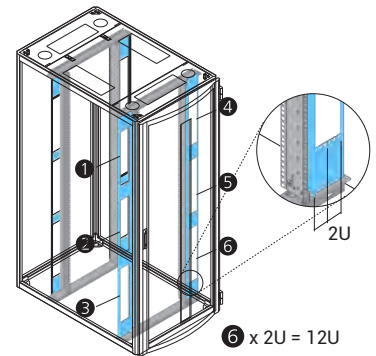

Zero-U mounting option - 12U

#### Front and rear depth adjustment alternatives

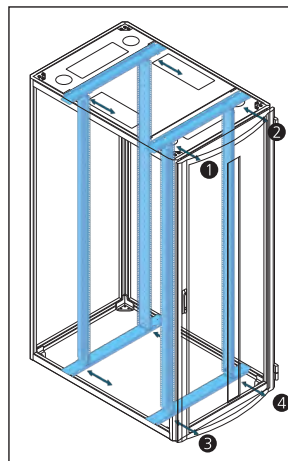

Position and depth adjustment at four points

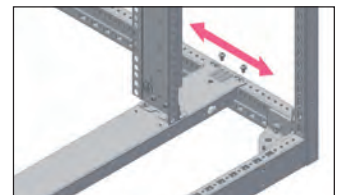

Standard type - Continuously adjustable

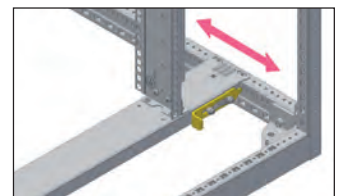

Slider type - Adjustable by 10mm steps



Seismic reinforced support rail

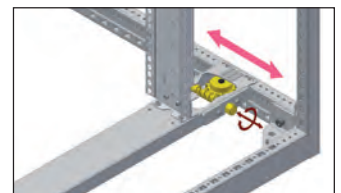

Mechanism type - Continuously adjustable

#### Castors

- Robust construction - plate type castor fixed on steel plate
- Steel ball bearing
- Standard type four-wheel set is designed to transport empty racks to initial place of use - each can rotate 360° degrees
- The heavy-duty castor set allows safe and comfortable movement of fully equipped racks loaded up to 1500 kg. Only front two of four wheels are capable of 360° degrees rotating.
- Cabinets equipped with heavy-duty castor set are UL 1678 certified for dynamic loading at 1500 kg

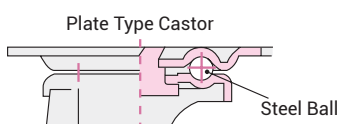

# DATA CENTER SOLUTIONS

## Rack Cabinet Systems

### Doors and Panels



#### Front and Rear Doors

- More airflow achieved with 85% perforation
- Thanks to the 180° opening of the doors, the aisle passage can be left free
- Rear split door wings can open 180° over to adjacent cabinets door when bayed side by side
- Opening direction of full-width doors can be changed on site whenever needed

Perforation Dimensions

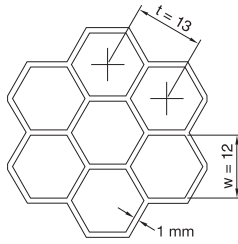

### KD Series



#### Removable / Attachable Door Design

- After the doors are opened 20°, they can be easily removed without the need for tools and then installed in the same way. The grounding cable with socket provides convenience.
- Any part that might be lost while the door is being removed, such as hinge pin, is not present.
- Attaching removing the door is only possible after unlocking. No security vulnerability occurs.
- Door opening direction can be changed on site.



180° hinge

#### Locking Options

- All lock options provide single-point locking as standard and four-point locking as option
- Combination lock or unique pass key option
- Electronic lock with keypad
- Electronic lock with card reader
- Electronic lock with finger print
- Biometric access control - iris
- Biometric access control - palm vein

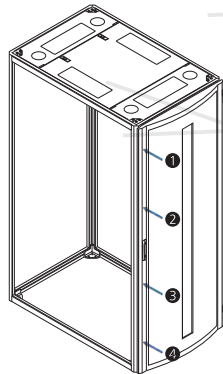
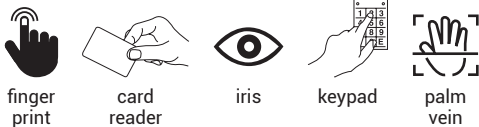

4 points locking alternative

#### Dedicated Cable Routing On Doors

- Necessary cable route for electronic locking system cabling inside the door is predefined
- Cable channels for temperature and airflow sensors are placed at top, mid- and lower height on the door

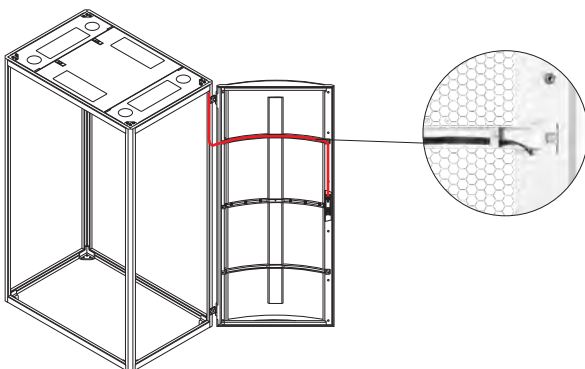

#### Bottom Cover

- Thanks to its segmented design, bottom cover
  - Ⓐ May not be used at all to provide access directly under the floor
  - Ⓑ Can be used at front or rear side for efficient airflow management
  - Ⓒ Can be used to completely close the bottom plane of the cabinet to prevent dust ingress or to provide full airflow control
- Thanks to their segmented structure and their design that they are positioned completely below the installation plane, bottom cover parts can be removed or fixed later at site provided the cabinet is empty
- Bottom covers enable entry of data and power cables at sides, front or rear of the cabinet's bottom
- There are various knockouts for cable entries where cable entry accessories can be placed

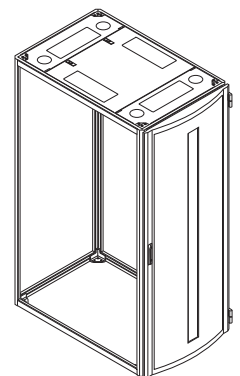

Ⓐ - Open

### KabinPLUS



#### Top Covers

- There are openings on the top covers that allow for the use of various cable passage accessories
- Top covers design provides possibility for mounting airflow management solutions that can be fixed to the upper parts of the cabinets
- Various top-of-cabinet cable management accessories can be selected, which are compatible with other features of the top covers
- The middle part of the top cover can be opened or removed and can be locked with an additional lock accessory if desired



#### Side Panels

- Vertically split side panels can be selected as either fixed types that are secured with screws or center-hinged types with key locks. Head-of-row types provide speed and ease of access to network cabinets at the end of aisles. Additionally, the fixed types have pass-through versions with transition openings for neighboring cabinets. Cable passage accessories are used in these transition openings
- Cabinets can be joined together while the side panels are attached. The presence and type of side panels do not affect the process of joining the cabinets side by side
- Side panels are designed and manufactured to be self-grounding during installation

Side panel options

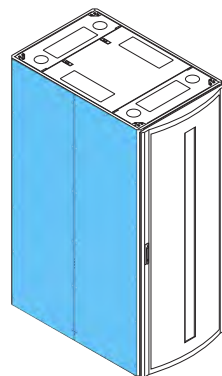

Fixed side panel

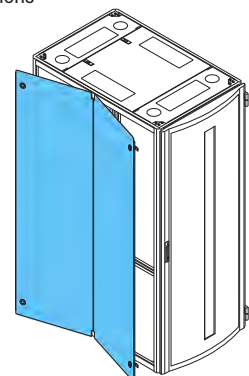

Hinged side panel

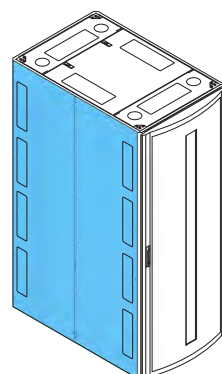

Transition type side panels

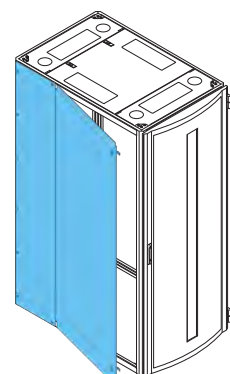

Head-of-row side panel

Bottom cover options

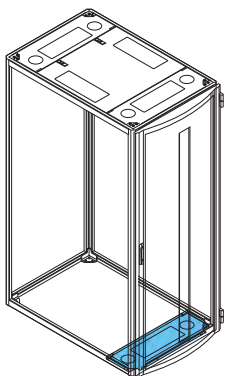

B - Partial covered

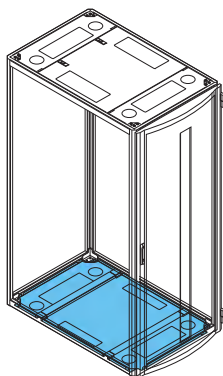

C - Closed

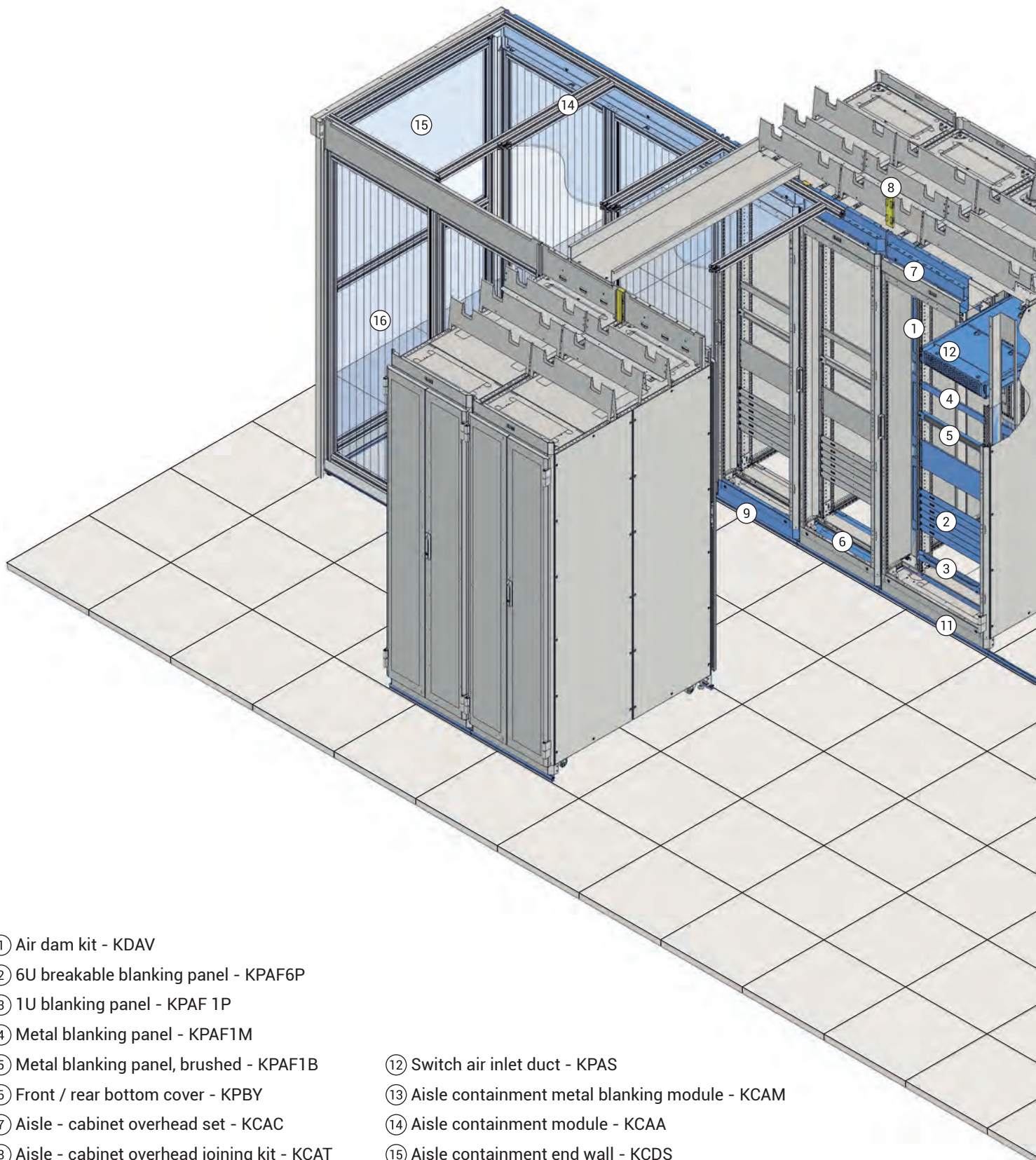

- ① Air dam kit - KDAV
- ② 6U breakable blanking panel - KPAF6P
- ③ 1U blanking panel - KPAF 1P
- ④ Metal blanking panel - KPAF1M
- ⑤ Metal blanking panel, brushed - KPAF1B
- ⑥ Front / rear bottom cover - KPBY
- ⑦ Aisle - cabinet overhead set - KCAC
- ⑧ Aisle - cabinet overhead joining kit - KCAT
- ⑨ Cabinet front-rear floor cover - KCAG
- ⑩ Cabinet side floor cover - KCAD
- ⑪ Cabinet floor gasket - KCAS

- ⑫ Switch air inlet duct - KPAS
- ⑬ Aisle containment metal blanking module - KCAM
- ⑭ Aisle containment module - KCAA
- ⑮ Aisle containment end wall - KCDS
- ⑯ Aisle containment module - vertical - KCAA
- ⑰ Aisle containment door - KCDT
- ⑱ Access control mounting module - KCES

# DATA CENTER SOLUTIONS

## Airflow Management



KabinPLUS

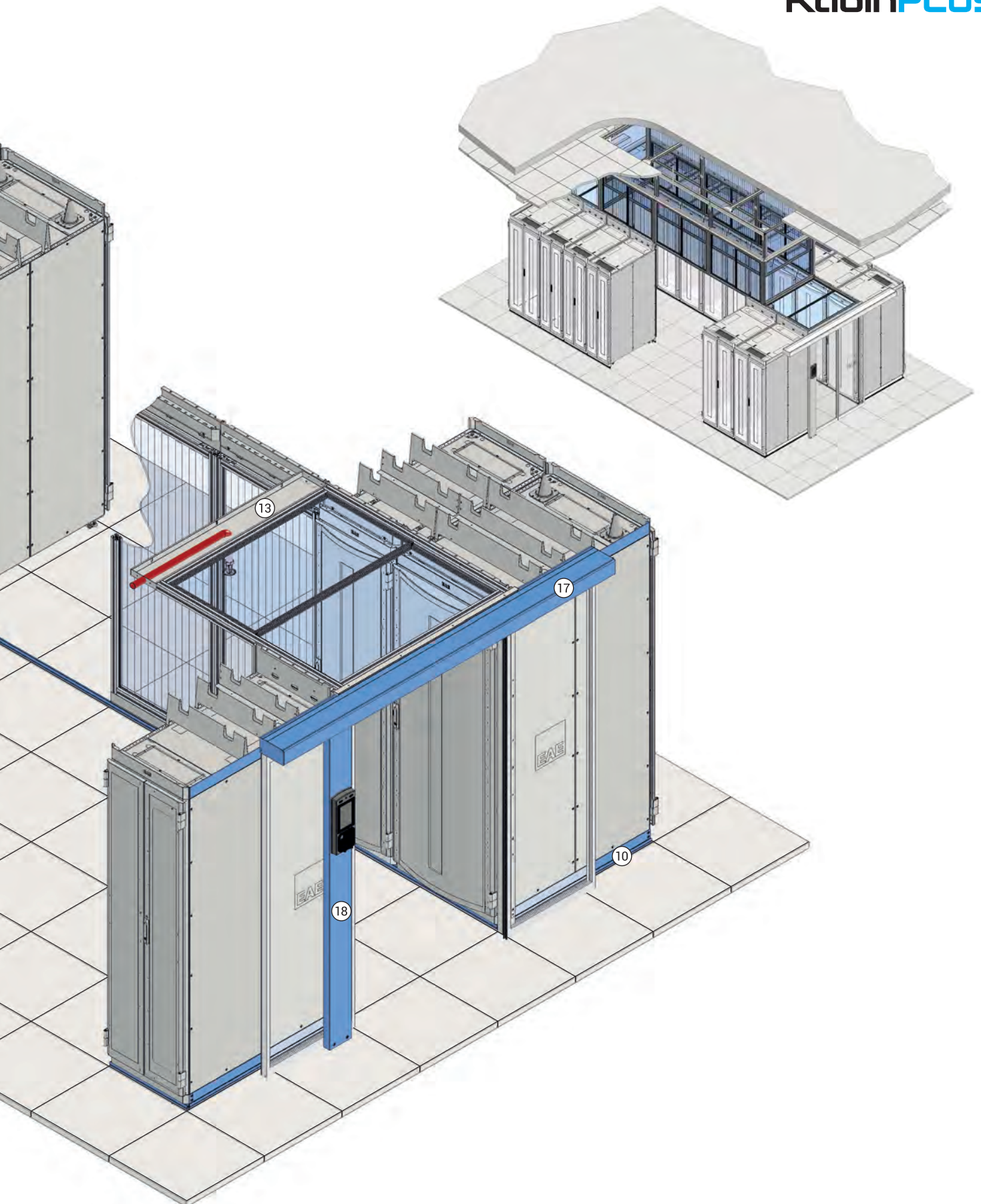

# DATA CENTER SOLUTIONS

## Rack Cabinet Systems

### KabinPLUS Aisle Containment Solution - Cold Aisle

---

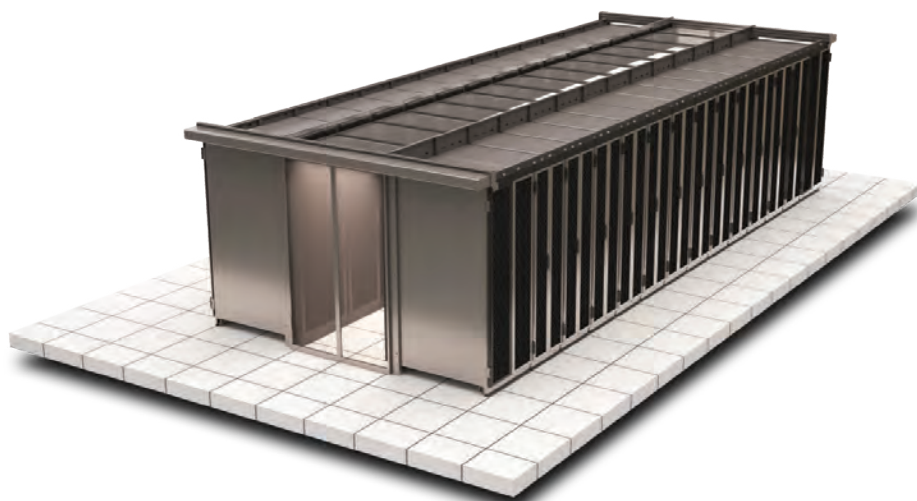

#### Overview

Cold Aisle Containment for rack cabinets with single or double sliding doors and sliding roof frame units made of aluminum with polycarbonate panel material and fire nozzle entry sections.

### KabinPLUS Aisle Containment Solution - Hot Aisle

---

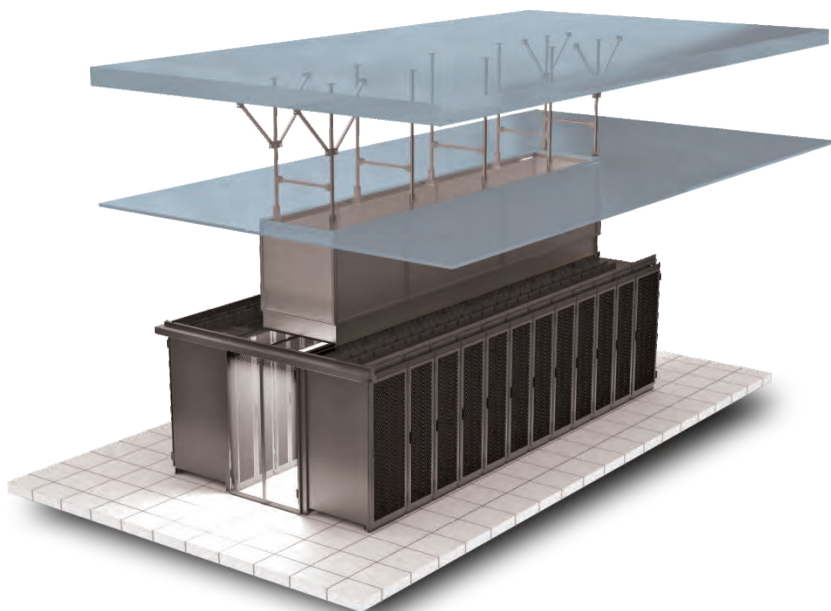

#### Overview

To ensure hot and cold air insulation to increase energy efficiency in suspended ceiling data center environments, an open chimney system to form the "Hot Aisle" made of aluminum frames with polycarbonate material is utilised where the hot air is directed to the plenum area.

Thanks to the specially designed fixing and flexible plastic isolation elements, the hot aisle chimney can easily be levelled and installed on top of the cabinets ensuring a flexible containment and airflow separation.

# DATA CENTER SOLUTIONS

## Rack Cabinet Systems

KabinPLUS Additional Physical Security



### Sliding Cage Solutions

KabinPLUS

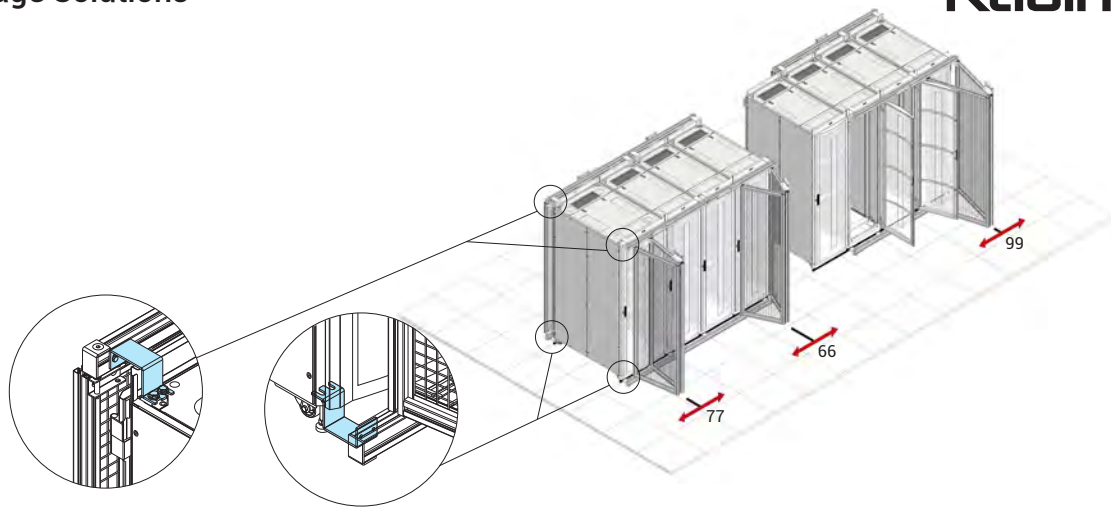

- Possibility of adding or removing sliding cage partitions when desired.
- Standard 2 cabinet or 3 cabinet sets can be combined for groups of 4, 5 or more cabinets.
- Sliding cage rails on the top and the floor are easily fixed to the robust cabinet construction when the doors are open.
- Fixation feature that does not require drilling holes in the floor
- It takes up negligible space in the white hall, saves space.
- Remote control feature of the electromagnetic lock (optional)
- Possibility of attaching a padlock (optional)

### Infinoo NG / Surface Mount Linear Tracking System LED Luminaire

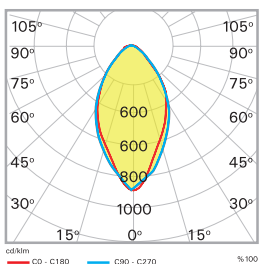

- Housing: Aluminium Extrusion Housing and Cover
- Operation Temperature: -20°/+45°C
- Light Source: Mid Power LED
- Correlated Light Colors: 4000K / 5700K / 6500K
- Optical Degree Options: 30° / 60° / 90° / Asymmetric / Double Asymmetric Lens
- Light Efficacy: 141.6 lm/W
- Operation Voltage: 220-240V AC, 50/60Hz
- Power Consumption: 35 W / 36 W / 42 W / 44 W / 52 W / 56 W / 64 W / 65 W / 78 W / 82 W

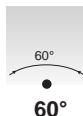

# DATA CENTER SOLUTIONS

## Type Tested Low Voltage Switchgear Systems

### Technical Specifications



Rated Current ( $I_n$ )	Up to 6800A
Rated Operational Voltage( $U_e$ )	690 V AC
Rated Insulation Voltage ( $U_i$ )	1000 V AC
Rated Short Time Withstand Current ( $I_{cw}$ )	Up to 120 kA -1 sec.
Rated Impulse Withstand Voltage ( $U_{imp}$ )	Up to 12 kV
Internal Arc	65 kA / 0,3 s.
Seismic Withstand	Up to 0,66 g
Form Separation Classes	Up to Form 4b
IP Protection Class	Up to IP55
Protection Class Against Mechanical Impact	IK10
Framework	Painted 2mm pre-galvanized steel
Colour	RAL 7035 epoxy-polyester electrostatic powder paint
Operating Temperature	-5 °C, +40 °C
Standards and Regulations	IEC/EN 61439-1/2 Low Voltage Switchgear and Controlgear Assemblies IEC/EN 62208 Empty Enclosures for Low Voltage Switchgear and Controlgear Assemblies IEC/EN 60529 Degrees of Protection Provided by Enclosures (IP Code) IEC/EN 62262 International Standard Degrees of Protection Provided by Enclosures for Electrical Equipment Against External Mechanical Impacts (IK Code) IEC 61641 Internal Arc Test IEC 60068 and IEEE-693/2005 "IEEE Recommended Practice for Seismic Design of Substations"

# DATA CENTER SOLUTIONS

## Type Tested Low Voltage Switchgear Systems

Freedom of Circuit Breaker Brand Selection



Type tests have been carried out in internationally accredited DEKRA laboratories according to the highest technical standards, using product groups from 8 different circuit breaker brands and full type test certificates have been obtained. With the PanelMaster Low Voltage Type Tested Switchgear Systems, we offer freedom to assemble type tested switchgears without being restricted to any specific circuit breaker brand.



PanelMaster Gold Partner List



PanelMaster Partner List



# DATA CENTER SOLUTIONS

## Type Tested Low Voltage Switchgear Systems

### Control and Licensing



In PanelMaster low voltage type tested switchgear systems, the licensing procedure is an exclusive process implemented by EAE Elektrotechnik. Only authorized PanelMaster partners are permitted to assemble and use PanelMaster switchgear system badge.

If a PanelMaster license badge is requested for switchgears whose assembly has been completed, the panelbuilder partner shall apply for inspection to the PanelMaster team for scheduling an on-site inspection in its assembly workshop.

The on-site inspection procedure starts first with checks whether all given documents related to the switchgear match with actual application. If no nonconformities are found in the documentation standard inspection procedure steps are carried out. After all inspection steps where various measurements made and photographs of each panel compartment are taken, the inspection form is completed in full. The inspection team then reports the completed inspection form and photographs to the licensing team. If the licensing team finds no nonconformities during their review, switchgears in question are licensed and license badges with serial numbers are released to be fixed on the switchgear. Switchgears without license badge are considered unlicensed and therefore not recognized as PanelMaster switchgear.

Through this process panelbuilder partners gain a better understanding of type tests and respective standards. Specifiers ensure that the specifications defined in their requirements are met and contracting as well as investment companies are confident to receive fully licensed and type tested switchgear system.

# DATA CENTER SOLUTIONS

## Lighting Systems









### Infinoo NG



#### Overview

Uninterrupted Data, Flawless Light: Meet Infinoo  
Optimized for data centers, Infinoo NG delivers  
reliable and uniform lighting to support your  
critical infrastructure.

#### Features

-  LED linear trunking system for power, control and emergency in one compact structure
-  High Efficiency: Up to 140 lm/W
-  Multiple optics: 30°, 60°, 90°, 30 x 90°, 25x105°, Asymmetric / Double Asymmetric
-  IP20 protection & IK02 impact resistance class
-  Operating temperature: -20°C to +45°C
-  DALI, emergency and sensor-compatible modular system
-  Fast, tool-free connection with plug-in modules
-  CRI > 80
-  Aluminium extrusion housing with sleek finish



### Limitless control for the next-generation lighting line



Discover More  
Scan to visit product page



### Why Infinoo NG for Data Centers?

#### Uniform & Glare-Free Lighting

Ensures shadow-free visibility in critical server environments, reducing visual fatigue during maintenance.

#### Quick & Tool-Free Installation

Minimizes downtime with plug-in modularity-ideal for time-sensitive data center operations.

#### Smart Control Integration

Fully compatible with DALI, sensors, and emergency modules for seamless automation and safety.



#### Overview

STL offers a seamless linear lighting solution tailored for the demanding environment of data centers. It can be used as a single module or extended in long lines for uniform illumination across server aisles (white space areas). With both surface-mounted and pendant installation options, STL combines technical precision with a clean design, ensuring optimal visibility without compromising the architectural integrity of

- Housing: Aluminium Extrusion Housing
- Optic: Opal Diffuser
- Lumen Efficiency: Up to 97 lm/W
- Power: 20 W ~ 100 W
- Protection Class: IP20
- Mounting Type: Pendant / Surface Mounted / Recessed Mounted

### BLM S NG



#### Overview

Bloom S NG is a reliable indoor lighting solution for industrial and commercial spaces. With its IP20-rated sheet metal housing, opal polystyrene diffuser, and efficient LED technology (up to 140 lm/W), it provides uniform illumination with long-lasting performance.

- Housing: Sheet Metal Housing
- Optic: Opal Polistren Diffuser
- Lumen Efficiency: Up to 140 lm/W
- Power: 24 W - 36 W
- Protection Class: IP20
- Mounting Type: Recessed Mounted



#### Overview

Toría Mega is a durable luminaire with advanced Mid Power LED technology, offering 15W–70W power and 3000K–6500K color options. With IP65 and IK09 ratings, it is ideal for industrial areas, parking lots, warehouses, technical spaces, and outdoor use.

Its opal diffuser provides uniform light, while the minimal aluminum body ensures both style and performance. Works reliably in  $-20^{\circ}\text{C}$  to  $+40^{\circ}\text{C}$ .

- Housing: Aluminium Extrusion Housing
- Optic: Opal Diffuser
- Lumen Efficiency: Up to 145 lm/W
- Power: 15 W ~ 70 W
- Protection Class: IP65
- Mounting Type: Surface Mounted



### YPL NG



#### Overview

YPL NG stands out with its fixture efficiency and belongs to the Linear Watertight Lighting family. With its durable IP66 housing and advanced LED technology, it delivers high energy savings.

It is an optimal solution for industrial facilities, warehouses, technical spaces, parking areas, and all projects requiring watertight lighting.

- Housing: Plastic Extrusion
- Optic: Opal Diffuser
- Lumen Efficiency: Up to 110 lm/W
- Power: 15 W ~ 53 W
- Protection Class: IP66
- Mounting Type: Surface Mounted / Pendant



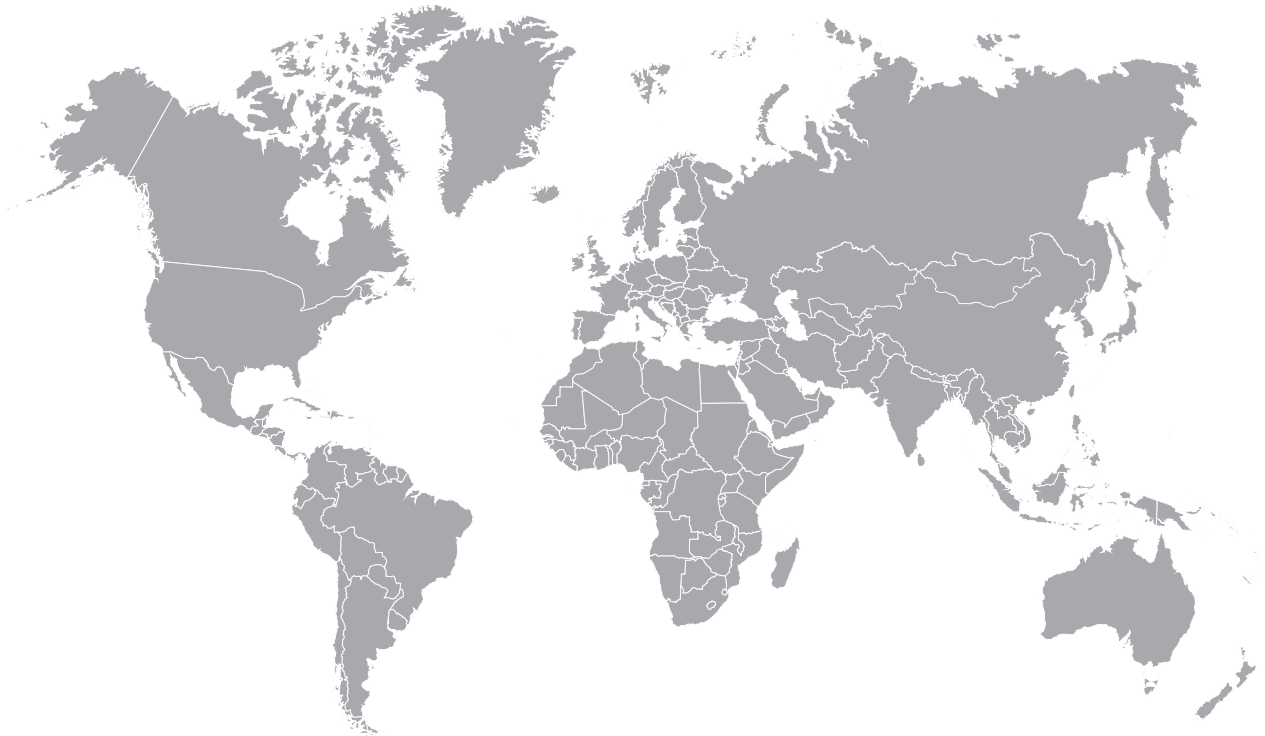

- @Home, Groningen
- Abu Dhabi Judiciary Department Data Center, Abu Dhabi
- Accelerated, Frankfurt
- Adalet Bankalığı IT Center, Istanbul
- ADJD PI Research Center, Abu Dhabi
- Airbus A29, Colomiers
- AIS SILA, Thailand
- Akbank Sabancı Center, Istanbul
- Alcatel Lucent Data Center, Istanbul
- Al Rumaith Data Center, Ksa
- Ancotel, Frankfurt
- Antares Bailly, Romainvilliers
- Aselsan IT Center, Ankara
- Asko Data Center, Oslo
- Astra Zeneca, Cambridge
- AXA Berchem
- Bahnhof AB Data Center, Stockholm
- Banco di Desio, Seriate
- Bank of America, Chennai
- BASE Aartselaar
- Basefarm, Oslo
- BCE GD, Luxembourg
- BNP PARIBAS; Romainvilliers, Bastogne, Vaux sur Sure,
- Borealis Data Center, Reykjavik, Iceland
- Boruce Tach Park, Bangalore
- Brigade Metropolis, Cognizant, Bangalore
- Brigade Tech Park, Bangalore
- British Telecom, LOT1&LOT2, Netherlands
- Cable & Wireless, München
- Calculationcenter RegioPolitie, Amsterdam
- Cap Gemini, Docklands UK
- Ced, RegioneToscana
- CEL Streak Software Park, Bangalore
- Cineca, Bologna
- Centraal Justitueel Incasso Bureau, Leeuwarden
- Cibicom Data Center, Denmark
- Cisco; Brussels, Amsterdam
- CitiBank Global Data Centre, Chennai
- Citibank, Thailand
- Clément Ader, Toulouse
- COLT, Les Ulis
- Computer Gross, Italy
- Crédit Agricole, Chartres
- CSIC Superior Council of Scientific Research, Madrid
- CVI Computercentrum, Utrecht
- Daimler RZ Geb. 11-2, Sindelfingen
- Data4 DC Cornaredo, Milan
- Datacenter Arnhem, Arnhem
- Datacenter BIT, Ede
- Datacenter De Bunker, Kloetinge
- Datacenter Flowtraders, Amsterdam
- Datacenter ITB2 Ecofactorij, Apeldoorn
- Datacenter Main Cubes, Amsterdam Schiphol
- Datacenter Mediapark, Hilversum
- Datacenter MUC 1, München
- Datacenter National Public Service Broadcasting, Hilversum
- Datacenter of Customs, Tver
- Datacenter Sjöbo Kommun, Sweden
- Datacenter World Stream, Naaldwijk
- Datacloud, Brussels
- Datahouse, Alkmaar
- Dataplace (Proserve), Alblasterdam
- Dataplex, Hungary
- Datazaal Hoofdkantoor RABO, Utrecht
- DC Smart (Van Nelle), Rotterdam
- DC05, Marcoussis
- Dammam 7 Data Center, Ksa
- Denizbank Data Center, Istanbul
- DETE-Immobilien, Stuttgart
- Deutsche Bank, Bangalore
- Deutsche Bundesbank , Germany
- Deutsches Klima Rechenzentrum, Hamburg
- DFAS Data Center, Norway
- DGR Telekom, Bursa
- Digiplex, Oslo
- Digital Realty, Amsterdam
- Doclerpro , Hungary
- DORA 2012
- DPC Data Center, Tver
- DROSBACH Cloche d'Or GD, Luxembourg
- DTO, Ministry of Defence, Airport Woensdrecht
- Equinix, Pantin-Paris
- Equinix, Amsterdam
- Equinix, Oman
- Equinix, Frankfurt
- Equinix, Istanbul
- Equinix, Milan ML2

- Equinix, Munich
- Equinix PA4.4 Pantin (93), France
- Equinix PA9 Paris, France
- Equinix, Perth
- Equinix, Sydney
- Ericsson AB, Linköping Gen-Power, Sweden
- ESDC Data center - Mumbai
- ESDS Solutions, Mumbai
- Etisalat Data Center - Khalifa City, Abu Dhabi, Al Ain,
- EU Networks, Halfweg
- EUROCLEAR Brussels
- EURONET II Brussels
- Evoswitch, Haarlem
- EVS Liège
- Fastweb (Internet provider) - Firenze, Bergamo, Roma, Bari, Catania, Palermo, Napoli
- Finansbank IT Center, Istanbul
- FORUM II Brussels
- France Telecom-Orange, Rueil Malmaison-Aubervilliers-Val de Rueil
- Free-Iliad, Vitry-sur-Seine
- Global Switch, Clichy
- Göteborgs Energi HK, Sweden
- Green Data Center - ABB, Switzerland
- Greenwich View Data Center, UK
- Grid Telekom, Ankara
- Halkbank Data Center, Istanbul
- HCL Infosys, Chennai
- Hoddesdon Data Center, UK
- Hyde Park Hayes Rackspace Data Center, UK
- Hydro66 Hydroelectric Data Center, Sweden
- IBM Data Center; Brussels, Greenford, Hurley, Bangalore
- IDFC Bank Chennai, India
- Imagination North London Data Center, UK
- InfraServ, Hürth
- Intel, Bangalore
- Interxion (La Courneuve, Paris), France
- Interxion AMS3, Schiphol Rijk, Netherlands
- Interxion MRS3, Marseille
- Interxion PAR8 Paris, France
- Interxion PAR9 Paris, France
- IP Only, Stockholm
- Irideus, Milan
- İş Bankası Operational Center Data Center, Istanbul
- İş Bankası Tuzla Data Center, Istanbul
- İTÜ National High Accuracy Calculation Center, Istanbul
- IX - EUROPE, Frankfurt
- Ixcelerate Data Center, Moscow
- KBC Datacenter, Leuven
- KKB Credit Registration Center Data Center, Istanbul
- KPN, Drentestraat, Amsterdam
- Kuveyt Türk Banking Station Data Center, Istanbul
- Khazna, Data Center
- L&T Data Center, India
- L&T, Chennai
- LCL Belgium, Brussels
- Level 3, Amsterdam
- Linköpings University Data Hall, Sweden
- Lucent Technologies, Bangalore
- Malta Data Center, Malta
- MAN RZ LDR-Gebäude, Dachau
- Megafon Data Center, Samara
- Mobily Abhur, Jeddah
- Mobily Data Center Obhur, Ksa
- Mobistar, Liège
- MTS Data Center, Novosibirsk
- Muscat Internation Airport MC3, Oman
- Natixis, Melun-Bailly
- Netmagic, Bangalore
- NEXT DC, (Sydney-2, Melbourne-2, Brisbane-2, Perth-2) Australia
- Nirlon IT Park, Mumbai
- Nournet, Riyadh
- Nova Data, Eindhoven
- Noovle, Moncalieri
- Noovle, Rozzano
- Noovle, Cassina de Pecchi
- NXS, Amsterdam
- Office Complex Datacenter Muscat, Oman
- Old Reel Store Scotland Data Center Phase 1 & 2, UK
- Optiver, Amsterdam
- Orange, Val de Reuil
- Orange, Chartre
- Polizia di Stato, Bari
- Poste Italiane, Roma
- RABO Bank, Dealingroom, Utrecht
- Radore Telekom Metrocity Data Center, Istanbul
- RAM Mobile Data, Utrecht
- RBS Bank, Birmingham
- Rechenzentrum Airbus, Ottobrunn
- Rechenzentrum EDEKA, Würzburg
- Rechenzentrum RTL, Luxemburg
- Rechenzentrum Universität, Konstanz
- Sabic Headquarter Data Center, Ksa
- Salpuria Tech Park, Bangalore
- SB-SB, Handelsbanken, Sweden
- Safehost SH2, Gland, Switzerland
- Selectel Data Center, Moscow and St. Petersburg
- SGK (Social Security Institution) Data Center, Ankara
- Signal Corp. Data Center, Qatar
- Sky, Roma
- SMALLS Brussels, Belgium
- SNCF Socrate - Phases 1 & 2, Lille
- Société Générale, Fontenay
- Sogei, Roma
- Sparkle Telecom Palermo, Sicily
- Stadtwerke Herne RZ TMR, Germany
- Statistic Landesamt Bayern, München
- SWIFT Brussels, Belgium
- Take Solutions Data Center, India
- T-Com Zentrale, Hamburg
- TCS (Adibatla, Hinjwadi, Infopark, Powoi, Sez Bajarat,Trivendrum), India
- TDC, Oslo 2011
- Teknik I Media Datacenter AB, Sweden
- Tele 2, Stockholm, Gen-Power, Sweden
- TeleCity – Phases 1 & 2, Courbevoie
- TeleCity AMS2 & AMS4; Wenckebachweg, Amsterdam
- Telecom Italia - Cesano Maderno, Mestre, Cassina de Pecchi, Rozzano, Aprilia, Acilia
- Telekomunikasyon Communication HQ, Ankara
- The Data Center Group, Netherlands
- THY Data Center, Istanbul
- T-Mobil II, Bonn
- T-Systems, München
- Turkcell, Gebze, İzmir, Ankara, Çorlu
- Türkiye Finans Katılım Bankası Data Center, Istanbul
- Turkuaz Data Center, Ankara
- Twin Datacenters, National Tax Authorities, Apeldoorn
- UK2 GROUP, London
- Uni Credit, Verona
- Unisource Brussels, Belgium
- University of Amsterdam, SARA Computer, Amsterdam
- UOB Operation Center Building, Thailand
- UZ-Leuven Leuven
- Vakıflar Bankası Data Center, Ankara
- Virtu (Equinix AMS1), Amsterdam
- Virtu Enfield Data Center, UK
- Vodafone, Arnhem
- Volta Great Sutton Street Data Center, UK
- Volvo Data, Gothenburg Gen-Power, Sweden
- WE Dare Rivium, Capelle a/d Ijssel, Netherlands
- Wide XS, Amsterdam
- Wipro (Bangalore, Cochin, Pune), India
- Woking Data Center, UK
- WTC, Bangalore
- YKBU Yapı Kredi Banking Center Data Center, Istanbul
- Zenium Data Center; Slough, Frankfurt, Istanbul

---

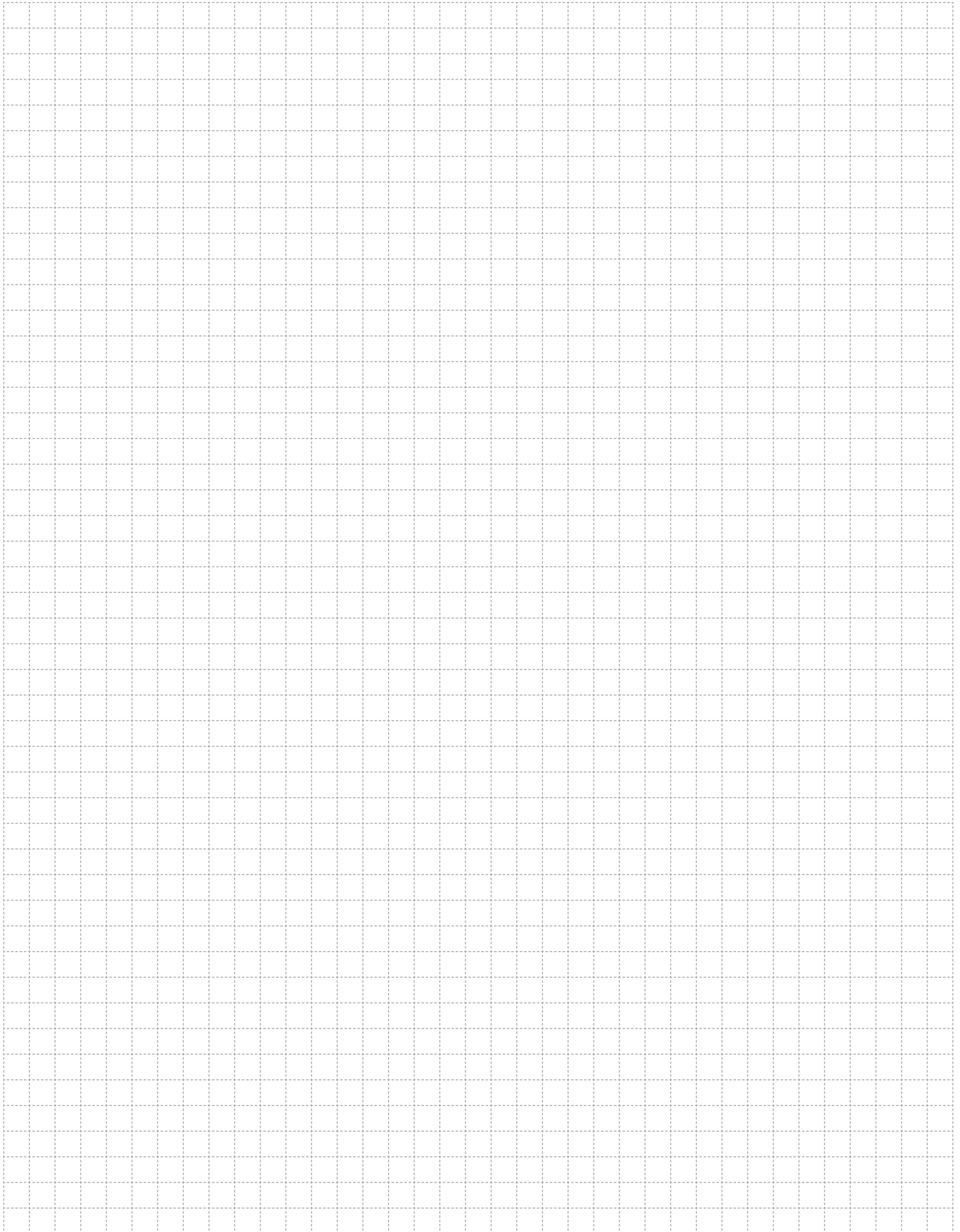

# SUSTAINABLE FUTURE

## Sustainability Management at EAE Elektrik



As part of our goal to support sustainable development and green transformation, measuring, evaluating, and managing all economic, environmental, and social impacts resulting from our sustainability practices is a key governance priority for EAE Elektrik. We act with great care in analyzing, monitoring, and managing the economic, environmental, and social impacts and risks that arise throughout our value chain in both our national and global operations.

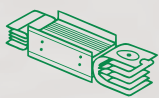

Busbar Systems

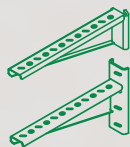

Support Systems

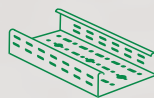

Cable Tray Systems

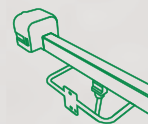

Trolley Busbar Systems



Fit-Out Solutions

*"We are working together with all our stakeholders to develop the electrical technologies that will build the future."*

You can visit our sustainability website at [sustainability.eaeelectric.com](https://sustainability.eaeelectric.com)



**EAE Elektrik**

**Head Office**

Akcaburgaz Mahallesi,  
3114. Sokak, No: 10 34522  
Esenyurt - Istanbul - Turkiye  
Tel: +90 (212) 866 20 00  
Fax: +90 (212) 886 24 20

**EAE DL 1 Factory**

**Cable Tray**

Organize Sanayi Bolgesi Mahallesi,  
6. Cadde, No: 2E, 41455  
Dilovasi - Kocaeli - Turkiye  
Tel: +90 (262) 999 05 55  
Fax: +90 (262) 502 05 70

**EAE DL 3 Factory**

**Busbar**

Organize Sanayi Bolgesi Mahallesi,  
6. Cadde, No: 6A, 41455  
Dilovasi - Kocaeli - Turkiye  
Tel: +90 (262) 999 05 55  
Fax: +90 (262) 502 05 69

**EAE Aydınlatma**

**Head Office**

İkitelli Organize Sanayi Bolgesi Mahallesi,  
Eski Turgut Ozal Caddesi No: 20 34490  
Basaksehir - Istanbul - Turkiye  
Tel: +90 (212) 413 21 00  
Fax: +90 (212) 549 37 90

**EAE Elektroteknik A.S.**

**Head Office**

İkitelli Organize Sanayi Bolgesi Mahallesi,  
Eski Turgut Ozal Caddesi No: 20/2  
Basaksehir - Istanbul - Turkiye  
Tel: +90 (212) 549 26 39  
Fax: +90 (212) 549 37 91  
www.eaeelektroteknik.com



Please visit our website for the updated  
version of our catalogues.  
[www.eaegroup.com](http://www.eaegroup.com)



Catalogue 17 - En. / Rev. 12 1000 Pcs. 06/01/2026  
N.G.

EAE has full right to make any revisions or changes on this catalogue without any prior notice.