

M O D E R N E



FEEL, FREESTYLE, DMETRIA E LIGHT
PORTE MODERNE
LACCATE, INCISE PANTOGRAFATE
LACQUERED, ENGRAVED AND PANTOGRAPHED MODERN DOORS

THE ITALIAN STYLE DOOR

Dierre

YOUR HOME. YOUR LIFE

M O D E R N E

UN COLORE NON È MAI UGUALE A SE STESSO

Le porte Dierre possono anche essere personalizzate (a seconda del modello) con i colori RAL e/o NCS.

La cartella colori RAL è una scala normalizzata molto utilizzata in ambito produttivo, soprattutto nel settore delle finiture e delle vernici. È stata creata nel 1925 dal Reichsausschuss für Lieferbedingungen e i codici RAL sono composti da 4 cifre, raggruppati per migliaia in base alla famiglia di colori.

NCS (Natural Colour System®) è un sistema logico di ordinamento dei colori che si basa sul modo in cui questi sono percepiti ed è riconosciuto in campo internazionale come il linguaggio universale dei colori perché aiuta i professionisti del colore in tutto il mondo, con un linguaggio univoco che non lascia spazio a errori di comunicazione. Per mezzo del Sistema cromatico NCS, infatti, ogni possibile colore di superficie può essere descritto ed identificato con uno speciale codice (Notazione NCS).

Il Sistema NCS si fonda sui sei colori elementari e non associabili a livello percettivo ad alcun altro colore: bianco (W), nero (S), giallo (Y), rosso (R), blu (B) e verde (G). Le notazioni dei colori NCS si basano sulla somiglianza con questi sei colori elementari.

Il sistema RAL cataloga un insieme arbitrario e ristretto di sfumature ben definite e standardizzate, quello NCS invece fornisce un codice in grado di identificare univocamente i 10 milioni di tinte che l'occhio umano è in grado di percepire.

A COLOUR NEVER FULLY RESEMBLES ITSELF.

The Dierre doors can also be customized (depending on the model) with RAL and NCS colours.

The RAL colour card is a normalized scale very used in manufacturing, especially in the field of finishes and paints. It was created in 1925 by Reichsausschuss für Lieferbedingungen and the RAL codes are composed of 4 digits, grouped by thousands based on the colour group.

NCS (Natural Color System®) is a logical colour ordering system based on the way these are perceived and is internationally recognized as the universal language of colours as it helps colour professionals worldwide use a unique language that leaves no room for communication errors. In fact, by means of the NCS chromatic system every possible surface colour can be described and identified through a special code (NCS notation). The NCS System is based on the six elementary colours and cannot be associated to the perceptive level to any other colour: white (W), black (S), yellow (Y), red (R), blue (B) and green (G). The NCS colour notations are based on the similarity with these six elementary colours.

The RAL system orders an arbitrary and narrow set of well-defined and standardised shades, the NCS instead provides a code able to univocally identify the 10 million colours that the human eye is able to perceive.

Le informazioni presenti in questo catalogo possono subire variazioni.

I materiali rappresentati sono puramente indicativi: per la verifica dei colori si rimanda al campionario.

The information contained in this catalogue may undergo variations.

The materials shown are a bare example: for the verification of colours please refer to the sample collection.

Forme astratte e geometriche entrano in casa con le nuove porte moderne firmate Dierre. Quattro collezioni di porte laccate dalle superfici disegnate per conferire personalità ad ogni ambiente. Freestyle scatena la fantasia con profonde incisioni pantografate che sembrano realizzate "a mano libera", Dmetria ispira la creatività grazie alle sue trame e layer sovrapponibili, Light mostra l'eterna eleganza delle linee semplici mentre Feel è la porta dedicata al cliente sofisticato che ama le superfici materiche. Le moderne Dierre, porte speciali che valorizzano lo spazio arricchendo la casa di creatività e tecnologia.

Abstract and geometric shapes come into the house with the new modern doors endorsed by Dierre. Four collections of lacquered doors with patterned surfaces to give each environment its personality. Freestyle unleashes the imagination with deep pantographed engravings that look like freehand-made, Dmetria inspires creativity thanks to its patterns and superimposable layers, Light shows the timeless elegance of simple lines while Feel is dedicated to the sophisticated customer who loves textured surfaces. Dierre modern doors are special doors that enhance the space by enriching the house with creativity and technology.

FEEL	4
FREESTYLE	16
DMETRIA	34
LIGHT	52
PORTA BLINDATA PER INTERNI / INTERNAL SECURITY DOOR SILENCE	64



ISOLAMENTO ACUSTICO SOUND INSULATION

Sempre più importante è l'**isolamento acustico**, che contribuisce in maniera determinante al comfort di un'abitazione, in particolare nel caso di appartamenti collocati all'interno di grandi condomini.

Un'esigenza molto sentita anche da chi vive la casa come luogo di lavoro, vista la recente crescita del fenomeno smart working.

La grande novità è la certificazione acustica su quasi la totalità dei modelli di porte interne Dierre. Quelle delle linee Moderne sono tutte disponibili in diverse classi di isolamento acustico: **si parte dai 29 dB**

delle soluzioni con cerniere a vista per salire a 30 dB con le cerniere a scomparsa, ai 32 dB delle porte con anta in truciolare forato e raggiungere i 36 dB con l'utilizzo di speciali feltri isolanti in fibra di riciclo.

Filum, la porta filomuro insonorizzata fino a 34 dB a richiesta, nella versione sia liscia che incisa.

Sound insulation is becoming increasingly important, as it makes a decisive contribution to the comfort of a home, particularly in the case of apartments located in large apartment buildings. A need that is also strongly felt by those who live in the home as a work space, given the recent growth of smart working.

*The big news is the sound insulation certification on almost all Dierre internal door models. Those of the Moderne lines are all available in different soundproofing classes: **starting from 29 dB of the versions with visible hinges and rising to 30 dB with concealed hinges, to 32 dB of the doors with perforated chipboard leaf and reaching 36 dB with the use of special insulating felts in recycled fibre.***

***Filum, the soundproof flush door up to 34 dB** on request, in both flush and engraved versions.*

FEEL



Feel 1 tranciato tessuto rovere grey
Feel 1 grey oak fabric

FEEL

Porta in legno tamburata
con trama tranciato tessuto o venato.
Guardala. Poi sfiorala, accarezza, sentila.
Perchè Feel parla agli occhi
e alla pelle di chi la scopre.
Una lavorazione rivoluzionaria
trasforma l'anta di legno
in superficie di seduzione tattile.
Matericità e design innovativo insieme,
con trama a tranciato tessuto o venato.
Ancora una volta, natura, immaginazione e
tecnologia creano un capolavoro.

*Wooden hollow core door
with woven or veined texture.
Look at it and then touch, caress, feel it.
Because Feel connects to the eyes
and skin of those who discover it.
A revolutionary process
turns the wooden door into a surface
that leads to tactile seduction.
Texture and innovative design together,
with woven or veined texture.
Once again, nature, imagination
and technology create a masterpiece.*

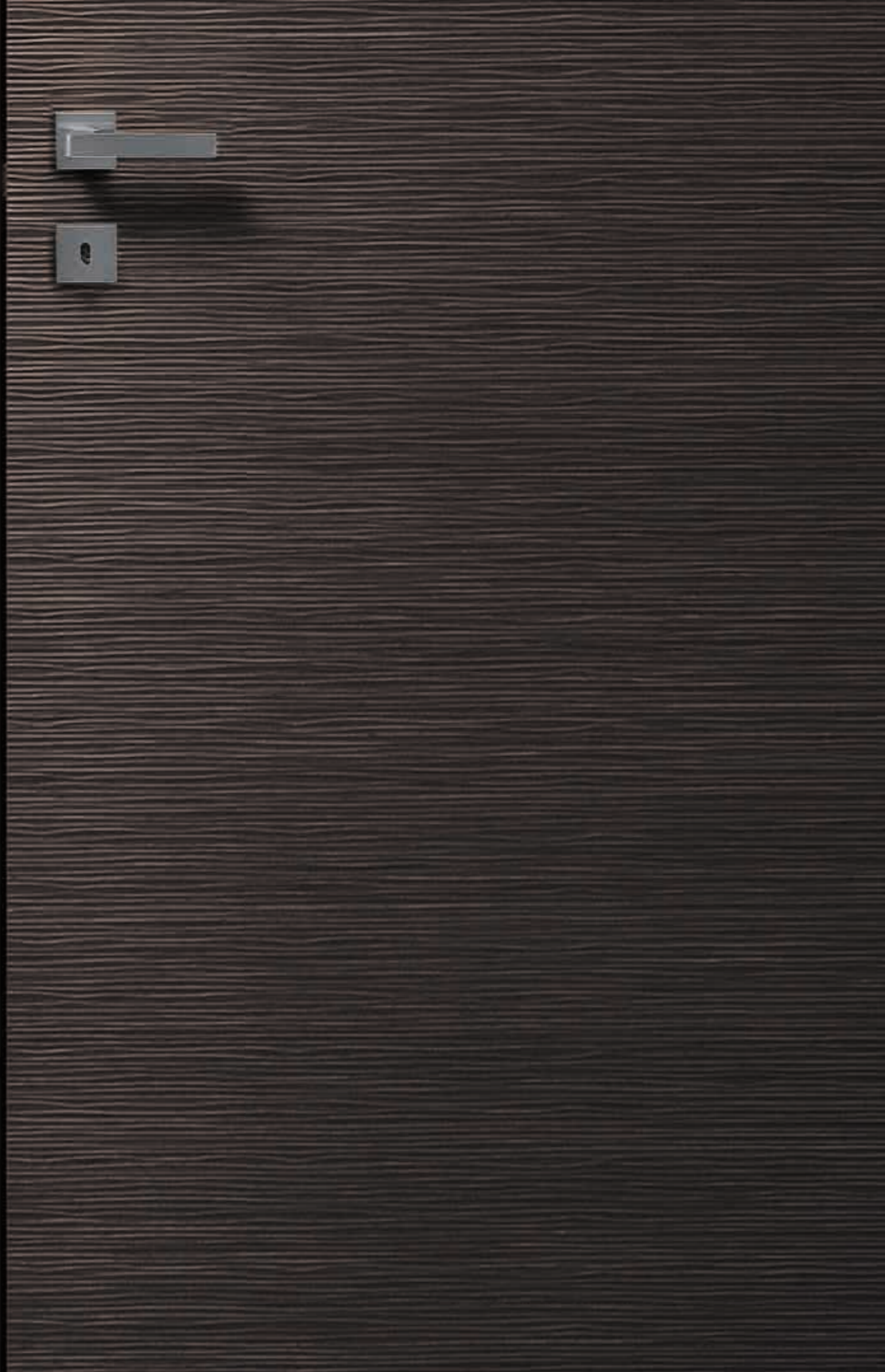

Il telaio realizzato in multistrato/MDF
è laccato e completo di guarnizione
di battuta.

*The frame made of multilayer/MDF
is lacquered and complete with stop seal.*



Il battente è fornito di serratura magnetica
con foro chiave in finitura cromo satinato.

*The door is equipped with a magnetic lock
with keyhole in satin chrome finish.*



L'anta tamburata, di spessore 44 mm ,
è supportata con MDF da 4 mm, con interno
in alveolare kraft, impiallacciata con tranciato
precomposto venato o tipo juta e laccata
con vernice di tipo poliuretano opaca.

*The 44 mm thick honeycomb-core door is supported
through a 4 mm MDF, with a kraft honeycomb core,
veneered with veined or jute type veneer
and lacquered with matt polyurethane varnish.*



Il battente è ferrato con 3 cerniere
a scomparsa in finitura cromo satinato.

*The door has 3 concealed hinges
in satin chrome finish.*

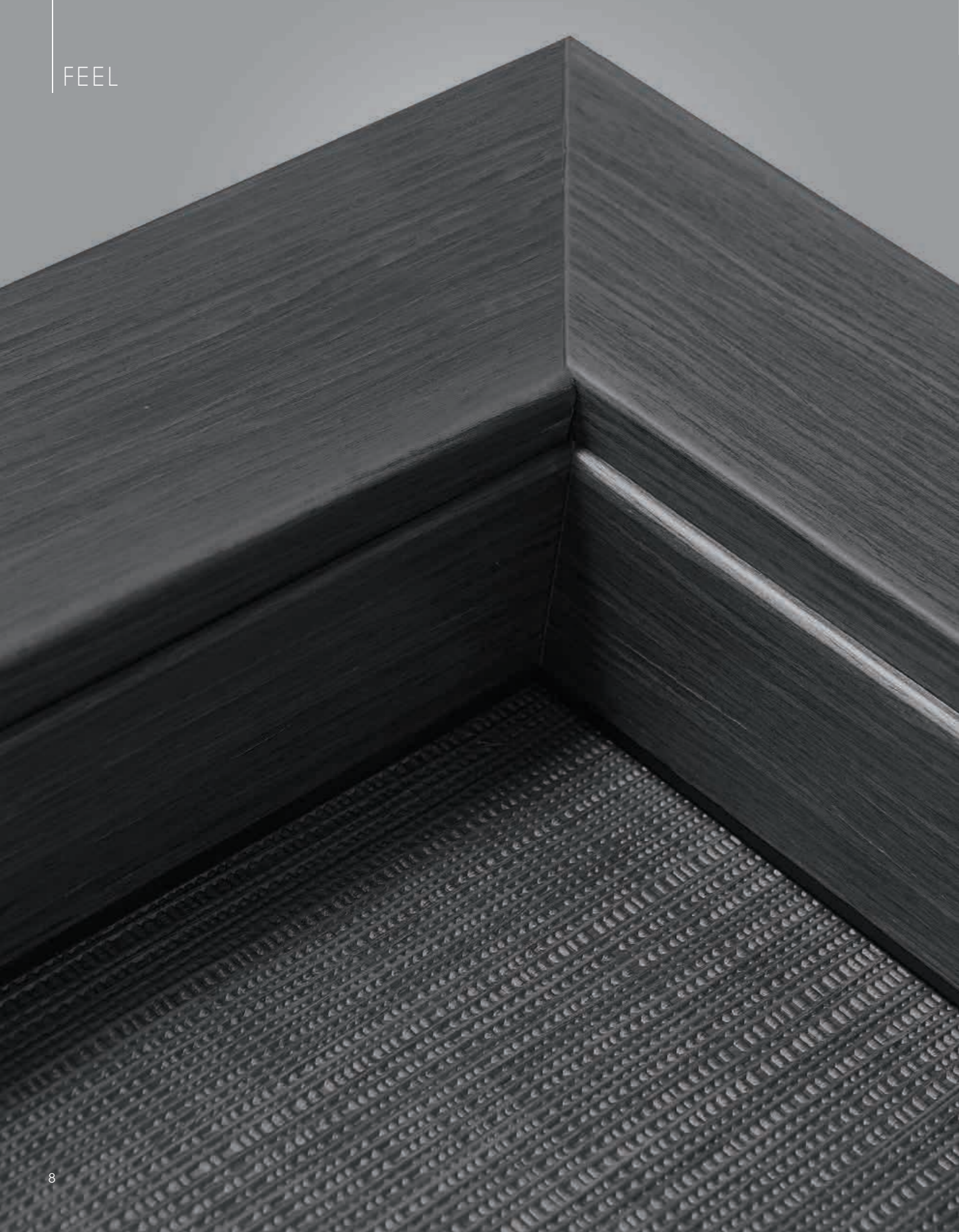

Versione | Feel 1
Colore | Tranciato tessuto rovere grey
Coprifilo | M93
Variant | Feel 1
Colour | Fabric-like veneer grey oak
Cover mould | M93



Versione | Feel 2
Colore | Tranciato venato rovere sbiancato
Coprifilo | M93
Variant | Feel 2
Colour | Grained veneer bleached oak
Cover mould | M93



allestimenti *lines*

FEEL 1



Tranciato tessuto
Fabric like veneer

FEEL 2



Tranciato venato
Grained veneer

soluzioni di apertura *opening variant*

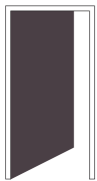

Battente singolo
Single leaf



Doppio battente
Double leaf



Anta pieghevole 1/3 - 2/3
Folding door 1/3 - 2/3



Scorrevole interno muro singolo
Single leaf sliding inside the wall



Scorrevole interno muro 2 ante
Two opposing leaves sliding inside the wall

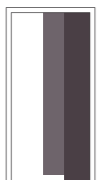

Scorrevole interno muro 2 ante sovrapposte
Inside the wall sliding door with two overlapping single leaves

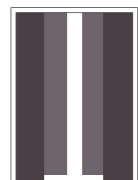

Scorrevole interno muro 2 ante sovrapposte doppie
Inside the wall sliding door with two overlapping double leaves



Scorrevole interno duetto
Duetto inside the wall sliding door



Scorrevole esterno muro
One leaf sliding outside the wall

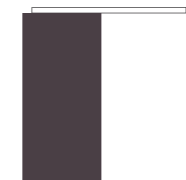

Porta ad un anta scorrevole esterno muro con mantovana nascosta
One leaf sliding outside the wall

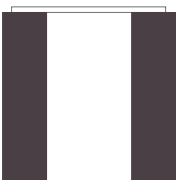

Scorrevole esterno muro 2 ante
Outside the wall sliding door with two single leaves

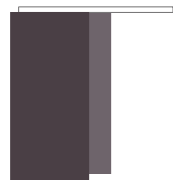

Scorrevole esterno muro 2 ante sovrapposte
Outside the wall sliding door with two overlapping single leaves



Scorrevole esterno muro 2 ante sovrapposte doppie
Outside the wall sliding door with two overlapping double leaves

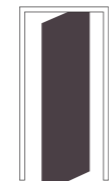

Anta rototraslante
Rototranslating door



Filum
Filum



Disponibile nelle versioni Opera E130 34dB/42dB e E160 37dB/47dB
Available in Opera models E130 34dB/42dB and E160 37dB/47dB



Sigillo di autenticità
Authenticity seal



Truciolare forato
Perforated chipboard



Truciolare lino pieno
Full flax chipboard



Serratura magnetica
Magnetic lock



Isolamento acustico
Sound insulation



Cerniera a scomparsa registrabile su tre assi
Concealed hinge adjustable on three axis

soluzioni telaio in legno *soluzioni telaio in legno*

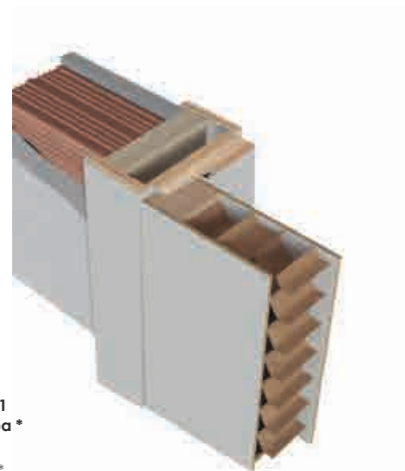

TELAIO STANDARD 1
con cerniera Anuba*
Special frame
with Anuba hinge*

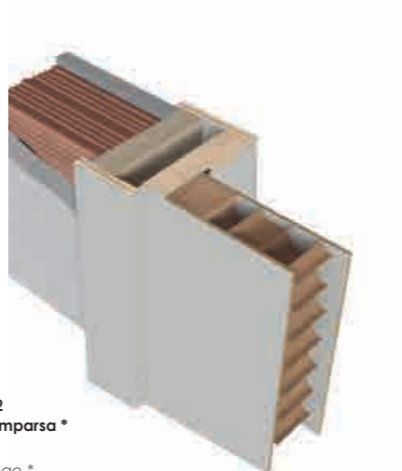

TELAIO STANDARD 2
con cerniera a scomparsa*
Special frame
with concealed hinge*

soluzioni telaio in alluminio *aluminium frame solutions*



TELAIO ALUTECH
con cerniera a bandella
ALUTECH FRAME
with strap hinge

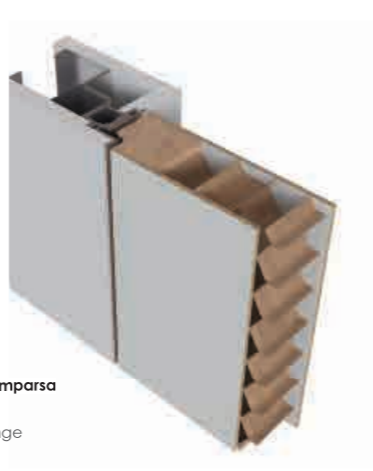

TELAIO FILUM
con cerniera a scomparsa
FILUM FRAME
with concealed hinge



TELAIO FILUM REVERSE
con cerniera
a scomparsa reversibile
FILUM REVERSE FRAME
with concealed reversible hinge

soluzioni telaio per porte tagliafuoco
frame solutions for fire doors

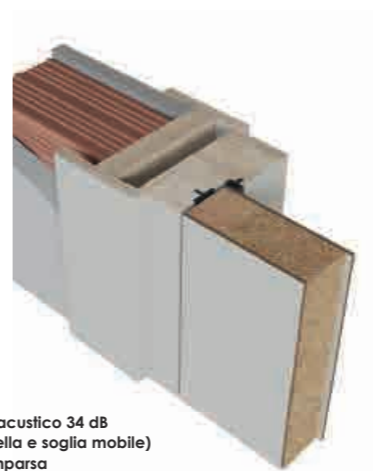

TELAIO EI30
con allestimento acustico 34 dB
(cerniere a bandella e soglia mobile)
e cerniere a scomparsa
EI30 FRAME
With sound-proofing fitting 34 dB
(flap concealed hinge and mobile
threshold) and with concealed hinge

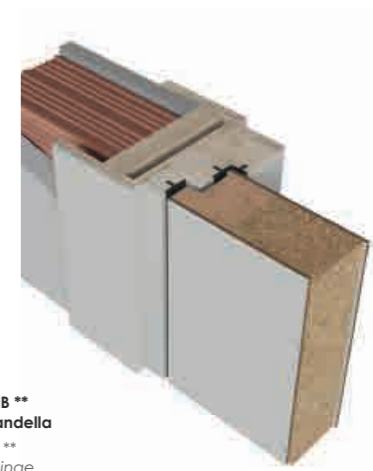

TELAIO EI60 - 37 dB**
con cerniera a bandella
EI60 FRAME 37 dB**
with concealed hinge

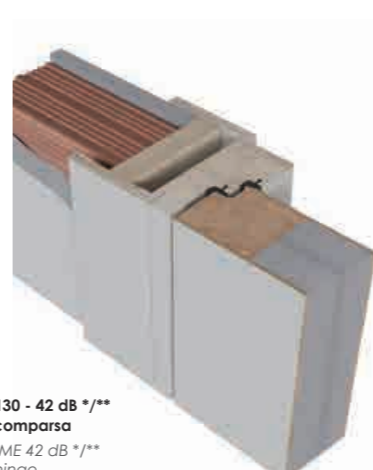

TELAIO D SUPER EI30 - 42 dB */**
con cerniera a scomparsa
EI30 D SUPER FRAME 42 dB */**
with concealed hinge

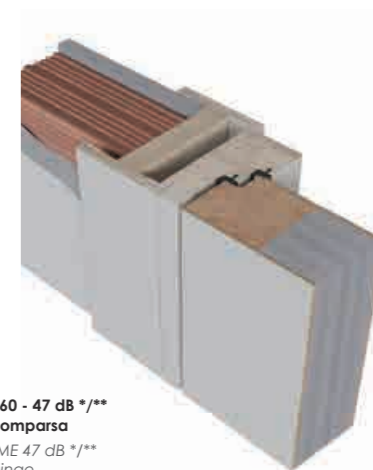

TELAIO D SUPER EI60 - 47 dB */**
con cerniera a scomparsa
EI60 D SUPER FRAME 47 dB */**
with concealed hinge

* Solo per quantitativi superiori a 100 pezzi / Only for quantities over 100 pieces
** Con allestimento acustico / With sound-proofing fitting

essenze e colorazioni per Feel 1
wood types and colors

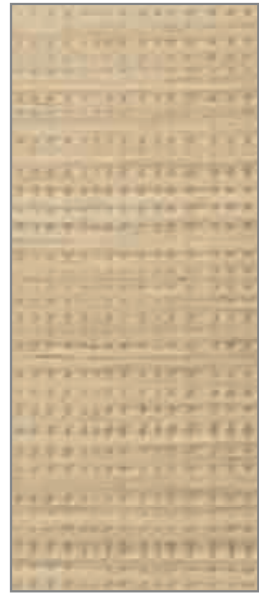

Tranciato tessuto rovere sbiancato
Bleached oak fabric

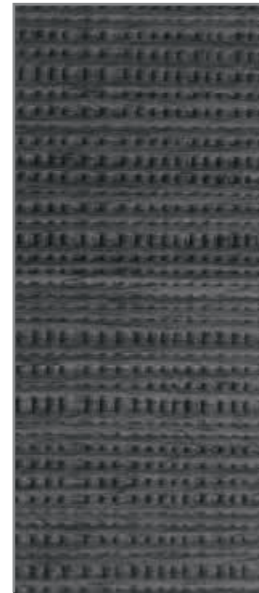

Tranciato tessuto rovere grey
Grey oak fabric



Tranciato tessuto rovere wengé
Wenge oak fabric



Tranciato tessuto laccato bianco B011
Lacquered B011 white fabric

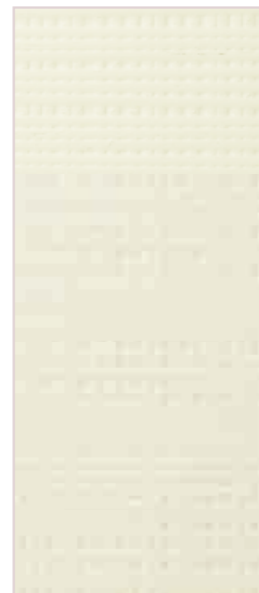

Tranciato tessuto laccato avorio
Lacquered ivory fabric

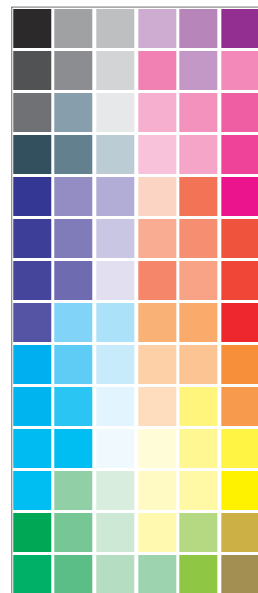

Laccato RAL* a scelta
Choice of RAL

essenze e colorazioni per Feel 2
wood types and colors



Tranciato venato rovere sbiancato
Bleached grained oak

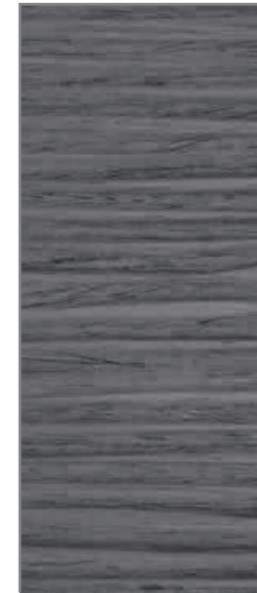

Tranciato venato rovere grey
Grey grained oak



Tranciato venato rovere wengé
Wenge stained grained oak



Tranciato venato laccato bianco B011
Grained lacquered B011 white



Tranciato venato laccato avorio
Grained lacquered ivory



Laccato RAL* a scelta
Choice of RAL

Freestyle



Freestyle

Porta laccata dal disegno deciso e contemporaneo, Freestyle si distingue come vero e proprio elemento di arredo. Il suo carattere si definisce scegliendo a piacimento nel catalogo delle incisioni disponibili e abbinandole alla gamma delle laccature, fino ad affiancarle a vetri con disegno analogo. Disponibile anche nelle nuove finiture d'arredo Portedi, selezionate NCS: terre d'argilla, violetta, grigio saturno, grigio tortora, ghiaccio, corda.

Lacquered door with a marked and contemporary pattern, Freestyle stands out as a true piece of furniture. Its character is defined by choosing the available engravings from the catalogue and combining them to the range of lacquering, up to matching them to glasses with similar design.

Available in the new Portedi furnishing finishes, NCS selected: clay soils, violet, Saturn grey, dove grey, ice, cord.

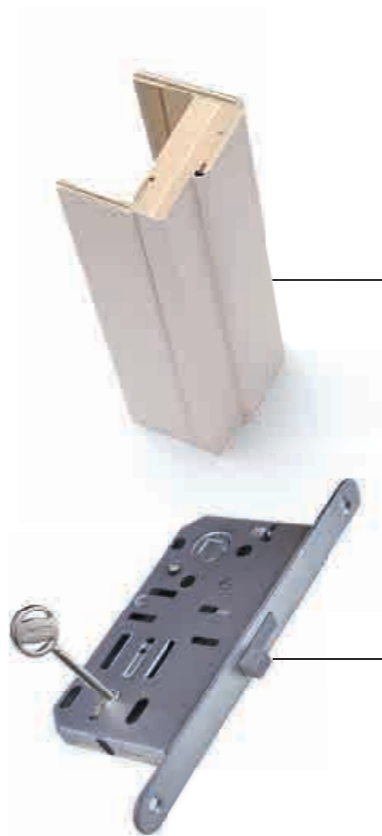

Il telaio listellare e i coprifili in multistrato garantiscono una elevata resistenza all'umidità. I coprifili da 7 cm con aletta da 2 cm per il lato interno e da 9 cm con aletta telescopica da 3 cm per il coprifilo esterno compensano perfettamente gli spessori parete fuorimisura e garantiscono la stessa altezza sia sul lato a spingere sia su quello a tirare.

The block board frame and the multilayer casing ensure high resistance to humidity. The 7 cm casing with 2 cm tab for the inner side and the 9 cm casing with 3 cm telescopic tab for the external casing perfectly compensate the non-standard wall thickness and ensure the same height both on the push and pull side.

Serratura magnetica. Lo scrocco indipendente dal magnete permette sempre la chiusura della porta. Incontro sul telaio di tipo registrabile che agevola la fase di posa in opera.

Magnetic lock. The latch is independent from the magnet and always allows the closing of the door. Adjustable frame striker that aids the fitting stages.

Controplacca registrabile
Adjustable counter plaque

Cerniera a scomparsa registrabile su 3 assi
con cover in finitura alluminio
Hinge with aluminium finish cover



Sigillo di autenticità
Authenticity seal

Serratura libero/occupato minimale della versione scorrevole
Minimal lock of the sliding version



Versione Sequoia
Colore Bianco B011
Coprifilo M90 45° esterno / M20 45° interno
Variant Sequoia
Colour B011 White
Cover mould M90 45° external/M20 45° internal



Versione X con inserti vetro
Colore Corda
Coprifilo M90 45° esterno / M20 45° interno
Variant X
Colour Rope
Cover mould M90 45° external/M20 45° internal



Versione Linee
Colore Avorio B003
Coprifilo M90 45° esterno / M20 45° interno
Variant Linee
Colour B003 ivory
Cover mould M90 45° external/M20 45° internal

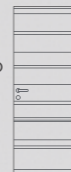

Versione Filum doppia Girandole
Colore Grigio Tortora
Variant Filum Girandole
Colour Dove Grey



Versione Alberi
Colore Terre d'Argilla
Coprifilo Rasé M90/T90
Variant Alberi
Colour Clay dirt
Cover mould Rasé M90/T90



Versione Bambù
Colore Ghiaccio
Coprifilo Rasé M90/T90
Variant Bambù
Colour Ice
Cover mould Rasé M90/T90



Versione Cascata
Colore Violetta
Coprifilo Rasé M90/T90
Variant Cascata
Colour Violet
Cover mould Rasé M90/T90



Versione Z
Colore Grigio Saturno
Coprifilo M90 45° esterno / M20 45° interno
Variant Z
Colour Saturn Grey
Cover mould M90 45° external / M20 45° internal

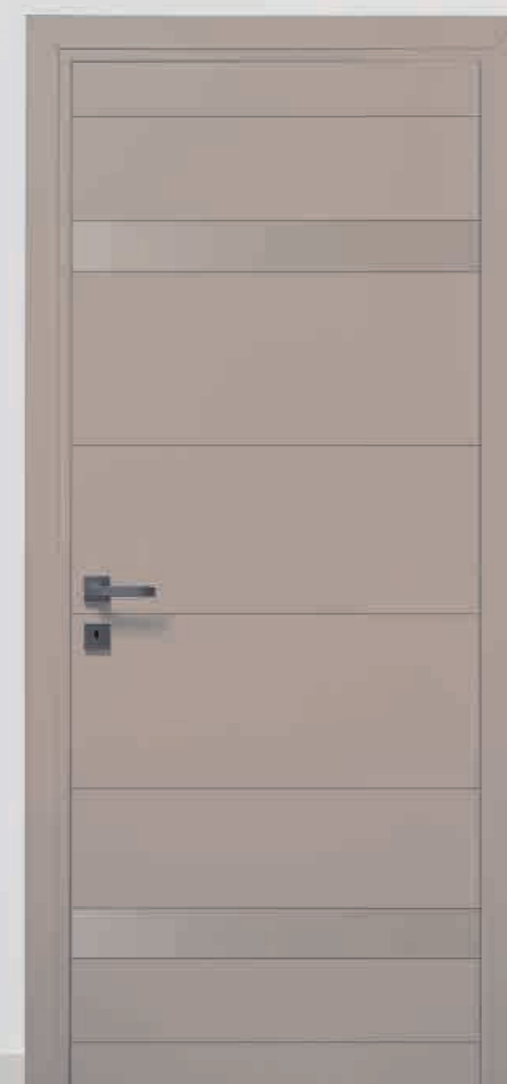
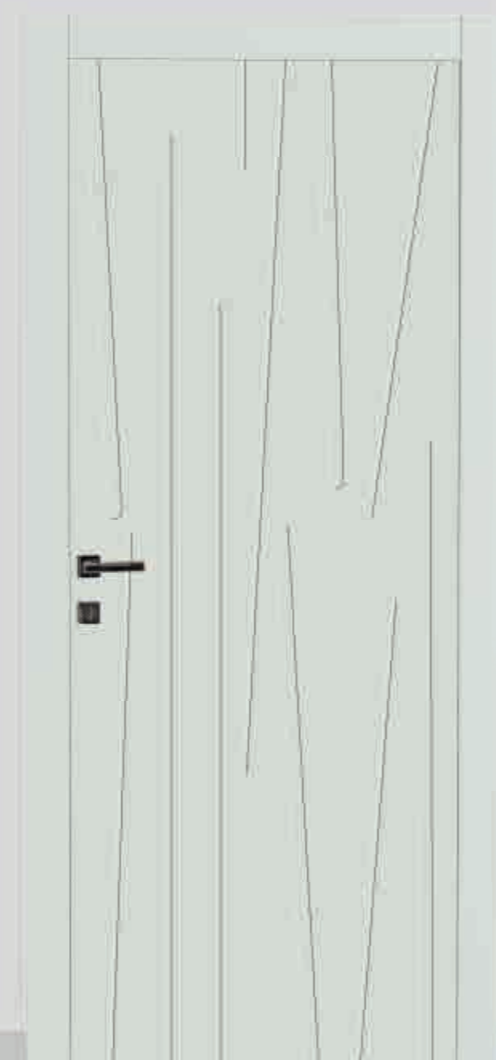
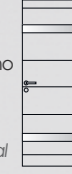

allestimenti lines

Freestyle cieche *blank*

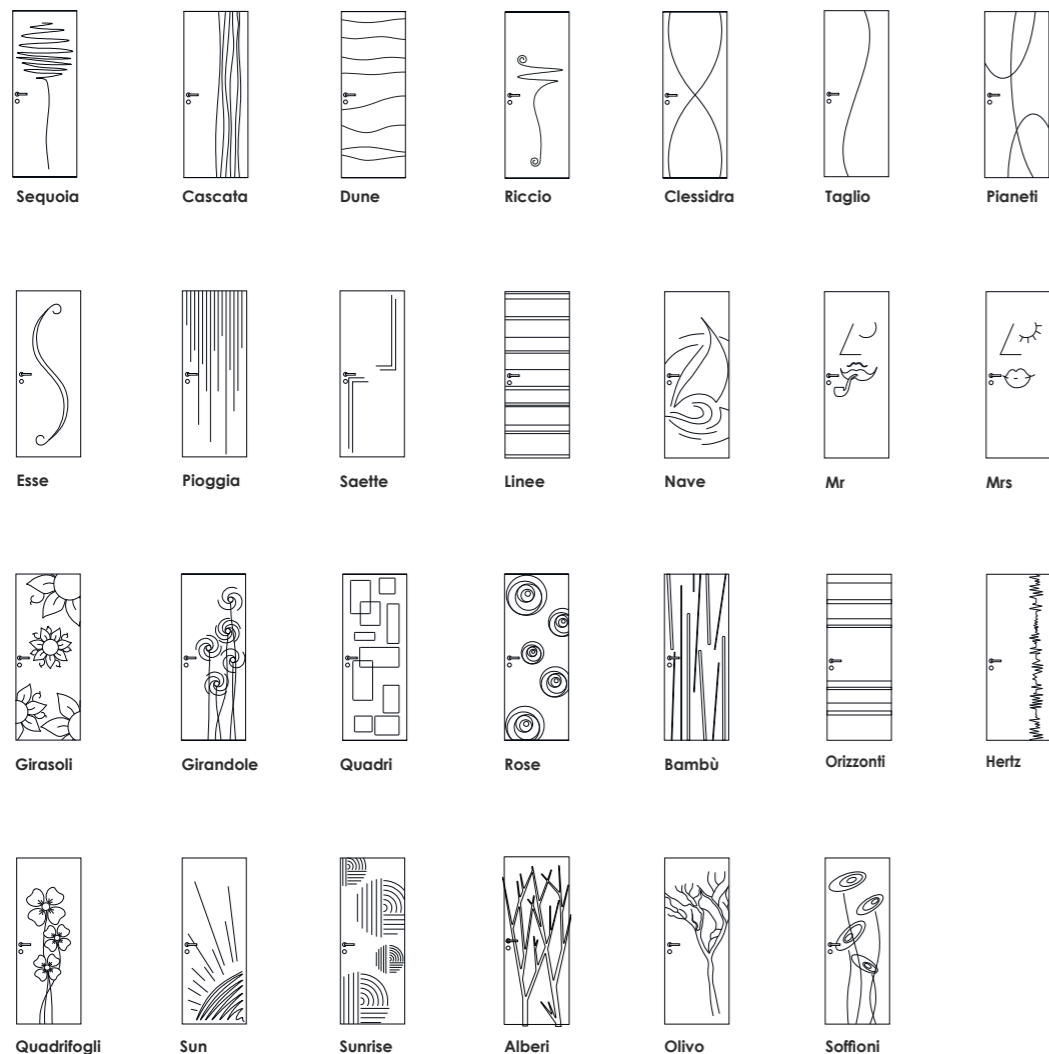

Freestyle con inserti vetro laccati *with lacquered glass inserts*

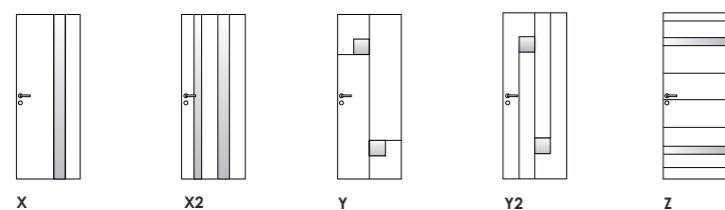

Freestyle pannello vetro a infilare *with slide-in glass panel*

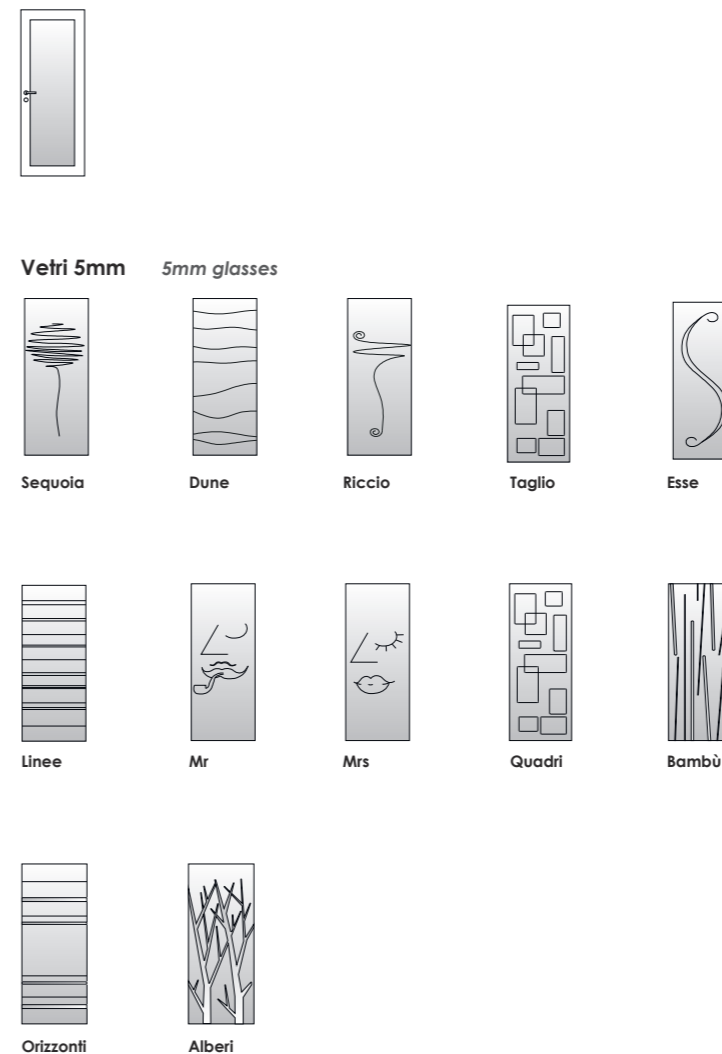

Vetri 5mm *5mm glasses*

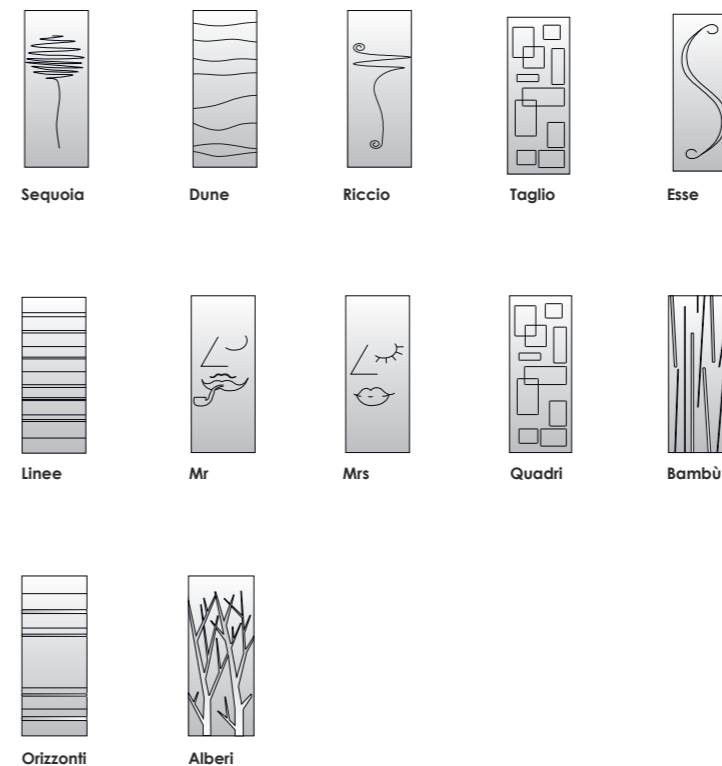

soluzioni di apertura *opening variant*



Battente singolo
Single leaf



Doppio battente
Double leaf

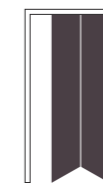

Porta pieghevole a libro singola
Single folding door

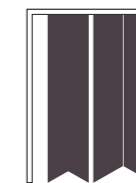

Porta due ante pieghevoli a libro
Double folding door



Scorrevole interno muro singolo
Single leaf sliding inside the wall

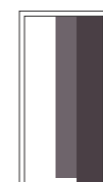

Scorrevole interno muro 2 ante sovrapposte
Inside the wall sliding door with two overlapping single leaves



Scorrevole interno muro 2 ante
Two opposing leaves sliding inside the wall



Scorrevole interno muro 2 ante sovrapposte doppie
Inside the wall sliding door with two overlapping double leaves

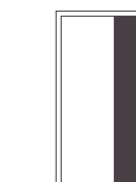

Scorrevole interno duetto
Duetto inside the wall sliding door

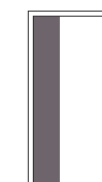

Scorrevole esterno muro
One leaf sliding outside the wall



Scorrevole esterno muro 2 ante sovrapposte
Outside the wall sliding door with two overlapping single leaves



Scorrevole esterno muro 2 ante
Outside the wall sliding door with two single leaves



Scorrevole esterno muro 2 ante sovrapposte doppie
Outside the wall sliding door with two overlapping double leaves



Bommer
Bommer



Bommer doppio
Double bomber

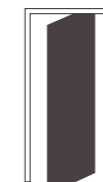

Anta rototraslante
Rototranslating door



Rasé
Rasé



Filum
Filum

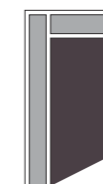

Sopraluce e fiancoluce
Fanlight and sidelight

soluzioni telaio in legno *soluzioni telaio in legno*

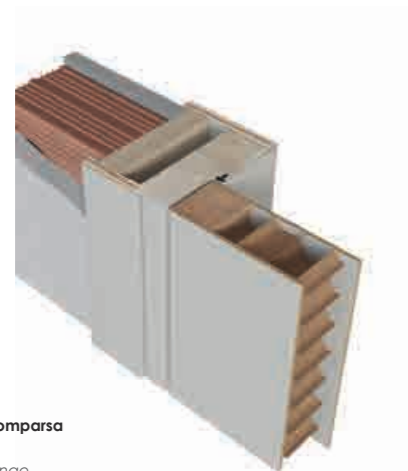

TELAIO STANDARD
con cerniera a scomparsa
Standard frame
with concealed hinge



TELAIO RASÉ SPINGERE
con cerniera a scomparsa
PUSH RASÉ FRAME
with concealed hinge

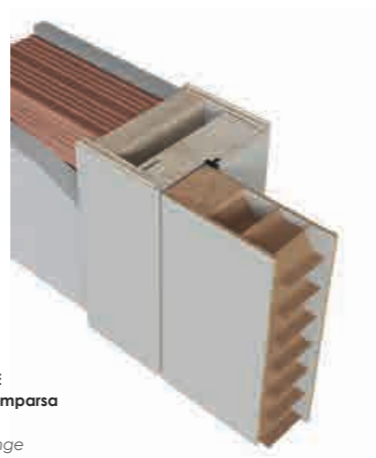

TELAIO RASÉ TIRARE
con cerniera a scomparsa
PULL RASÉ FRAME
with concealed hinge

soluzioni telaio in alluminio *aluminium frame solutions*

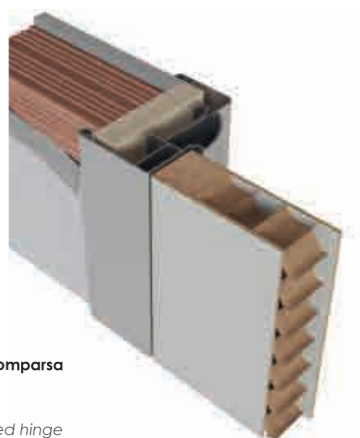

TELAIO ALUTECH
con cerniera a scomparsa
e/o a bandella
ALUTECH FRAME
with flap concealed hinge



TELAIO FILUM
con cerniera a scomparsa
FILUM FRAME
with concealed hinge

soluzioni telaio per porte tagliafuoco
frame solutions for fire doors

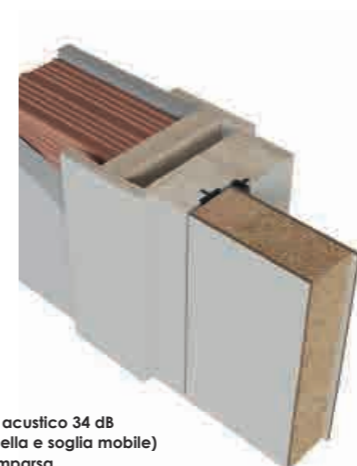

TELAIO EI30
con allestimento acustico 34 dB
(cerniere a bandella e soglia mobile)
e cerniere a scomparsa
EI30 FRAME
With sound-proofing fitting 34 dB
(flap concealed hinge and mobile
threshold) and with concealed hinge

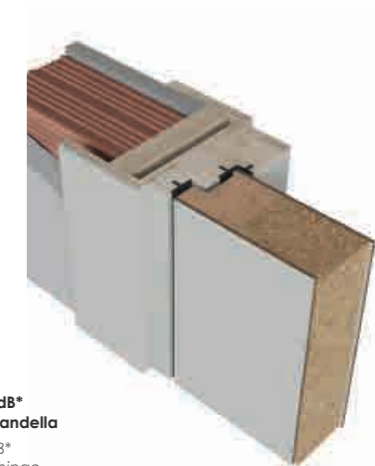

TELAIO EI60 - 37 dB*
con cerniera a bandella
*EI60 FRAME 37 dB**
with concealed hinge

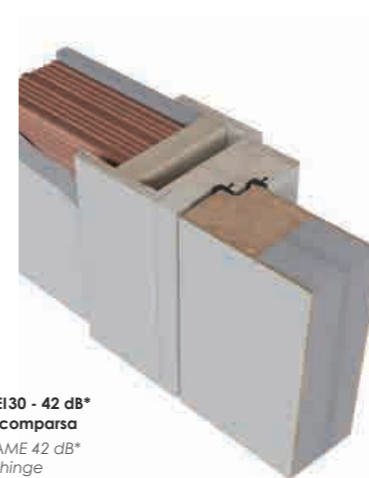

TELAIO D SUPER EI30 - 42 dB*
con cerniera a scomparsa
*EI30 D SUPER FRAME 42 dB**
with concealed hinge

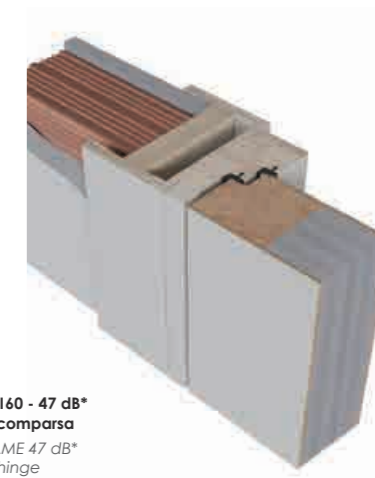

TELAIO D SUPER EI60 - 47 dB*
con cerniera a scomparsa
*EI60 D SUPER FRAME 47 dB**
with concealed hinge

* Con allestimento acustico / *With sound-proofing fitting*



Resistenza all'umidità
Telaio in listellare resistente all'acqua
Resistance to moisture
Water resistant blockboard



Disponibile nelle versioni Opera
EI30 34dB/42dB e EI60 37dB/47dB
Available in Opera models
EI30 34dB/42dB and EI60 37dB/47dB



Sigillo di autenticità
Authenticity seal



Truciolare forato
Perforated chipboard



Truciolare lino pieno
Full flax chipboard



Serratura magnetica
Magnetic lock



Isolamento acustico
Sound insulation



Finitura coordinata per tutte le porte di casa,
rivestimento blindato e battiscopa
Matching panelling
for all your home doors



Cerniera a scomparsa
registrabile su tre assi
Concealed hinge
adjustable on three axis

essenze e colorazioni *wood types and colors*

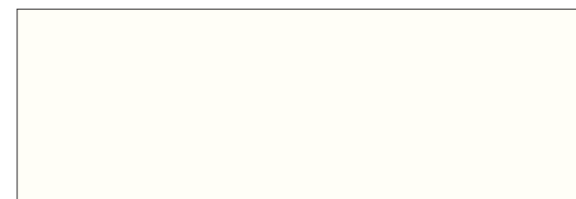

Bianco B011
B011 White



Avorio B003
B003 ivory



Violetta
Violet
NCS S 3005 - R 20B



Grigio Saturno
Saturn Grey
NCS S 3005 - Y 80R

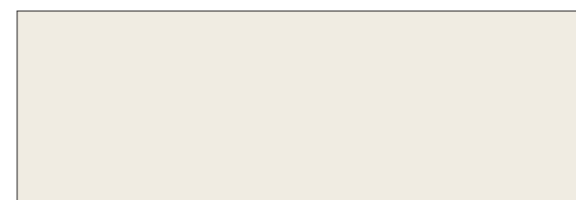

Terre d'Argilla
Clay dirt
NCS S 1002 - Y



Corda
Rope
NCS S 1005 - Y 10R



Ghiaccio
Ice
NCS S 1005 - G

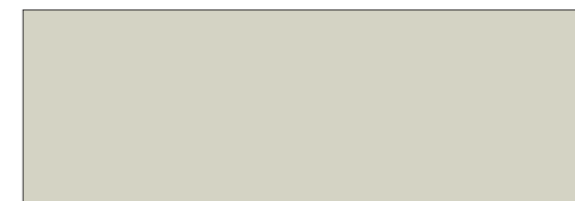

Grigio Tortora
Dove Grey
NCS S 3005 - G 80Y

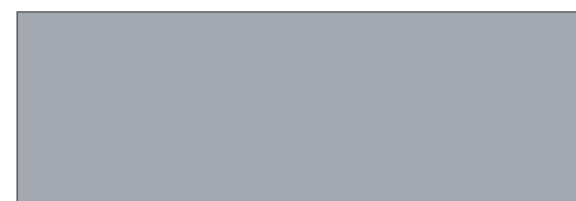

Grigio Dierre
Dierre Grey

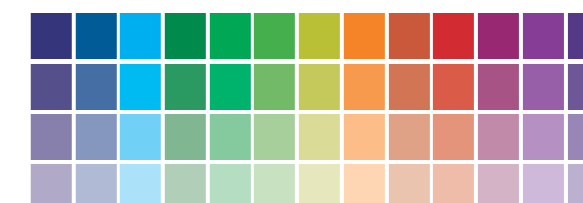

RAL* / NCS



DMETRIA

Porta laccata di stile contemporaneo arreda con eleganza offrendo al cliente la possibilità di combinare tre livelli di pantografatura e due disegni alternativi: la linearità delle "strade" o la morbidezza dei "fiumi". Abbinata al nuovo telaio minimale rasé, grazie alla perfetta complanarità di anta e telaio, garantisce un risultato di sicura eleganza. Disponibile anche nelle nuove finiture d'arredo Portedi selezionate NCS: terre d'argilla, violetta, grigio saturno, grigio tortora, ghiaccio, corda.

Contemporary style lacquered door, its elegant features give the customer the possibility to combine three pantographing levels and two alternative patterns: the linearity of "roads" or the softness of "rivers". Combined with the new minimal rasé frame, thanks to the perfect flushness of door and frame, it guarantees the utmost elegant touch. Available in the new Portedi furnishing finishes, NCS selected: clay soils, violet, Saturn grey, dove grey, ice, cord.



Il telaio listellare e i coprifili in multistrato garantiscono una elevata resistenza all'umidità. I coprifili da 6,5 cm con aletta da 2 cm per il lato interno e da 9 cm con aletta telescopica da 3 cm per il coprifilo esterno compensano perfettamente gli spessori parete fuorimisura e garantiscono la stessa altezza sia sul lato a spingere sia su quello a tirare.

The block board frame and the multilayer casing ensure high resistance to humidity. The 6,5 cm casing with 2 cm tab for the inner side and the 9 cm casing with 3 cm telescopic tab for the external casing perfectly compensate the non-standard wall thickness and ensure the same height both on the push and pull side.

Serratura magnetica. Lo scrocco indipendente dal magnete permette sempre la chiusura della porta. Incontro sul telaio di tipo registrabile che agevola la fase di posa in opera.

Magnetic lock. The latch is independent from the magnet and always allows the closing of the door. Adjustable frame striker that aids the fitting stages.

Controplacca registrabile
Adjustable counter plaque

Cerniera a scomparsa registrabile su 3 assi
con cover in finitura alluminio
Hinge with aluminium finish cover



Sigillo di autenticità
Authenticity seal

Serratura libero/occupato minimale della versione
scorrevole Minimal lock of the sliding version



Versione Strade Shangai BASE
Colore Grigio Saturno
Coprifilo Rasé M90/T90
Variant Strade Base BASE
Colour Saturn Grey
Cover mould Rasé M90/T90



Versione Strade Shangai LAYER 1
Colore Violetta
Coprifilo M90 45° esterno / M20 45° interno
Variant Strade Shangai LAYER 1
Colour Violet
Cover mould M90 45° external/M20 45° internal



Versione Strade Shangai LAYER 2
Colore Ghiaccio
Coprifilo Rasé M90/T90
Variant Strade Shangai LAYER 2
Colour Ice
Cover mould Rasé M90/T90



Versione Strade Shangai BASE +LAYER 1
Colore Avorio B003
Coprifilo M90 45° esterno / M20 45° interno
Variant Strade Shangai BASE +LAYER 1
Colour B003 ivory
Cover mould M90 45° external/M20 45° internal



Versione Strade Shangai BASE + LAYER 2
Colore Ghiaccio
Coprifilo M90 45° esterno / M20 45° interno
Variant Strade Shangai BASE + LAYER 2
Colour Ice
Cover mould M90 45° external / M20 45° internal

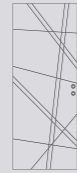

Versione Strade Shangai BASE + LAYER 1 + LAYER 2
Colore Bianco B011
Coprifilo M90 45° esterno / M20 45° interno
Variant Strade Shangai BASE + LAYER 1 + LAYER 2
Colour B011 White
Cover mould M90 45° external / M20 45° internal

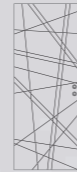

Versione Fiumi BASE
Colore Grigio Tortora
Coprifilo Rasé M90/T90
Variant Fiumi BASE
Colour Dove Grey
Cover mould Rasé M90/T90

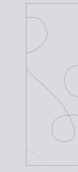

Versione Fiumi LAYER 1
Colore Ghiaccio
Coprifilo Rasé M90/T90
Variant Fiumi LAYER 1
Colour Ice
Cover mould Rasé M90/T90

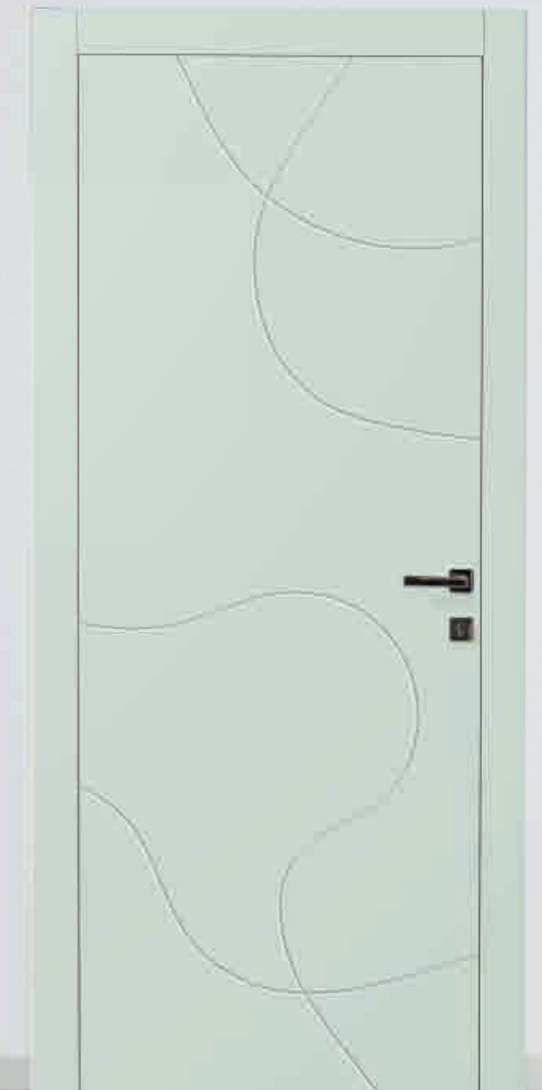

Versione	Fiumi LAYER 2
Colore	Avorio B003
Coprifilo	M90 45° esterno / M20 45° interno
Variant	Fiumi LAYER 2
Colour	B003 ivory
Cover mould	M90 45° external/M20 45° internal



Versione	Fiumi BASE +LAYER 1
Colore	Corda
Coprifilo	M90 45° esterno / M20 45° interno
Variant	Fiumi BASE +LAYER 1
Colour	Rope
Cover mould	M90 45° external/M20 45° internal



Versione	Fiumi BASE +LAYER 2
Colore	Violetta
Coprifilo	M90 45° esterno / M20 45° interno
Variant	Fiumi BASE +LAYER 2
Colour	Violet
Cover mould	M90 45° external/M20 45° internal



Versione	Fiumi BASE +LAYER 1 + LAYER 2
Colore	Grigio Saturno
Coprifilo	Rasé M90/T90
Variant	Fiumi BASE +LAYER 1 + LAYER 2
Colour	Saturn Grey
Cover mould	Rasé M90/T90



allestimenti *lines*

Strade Shangai

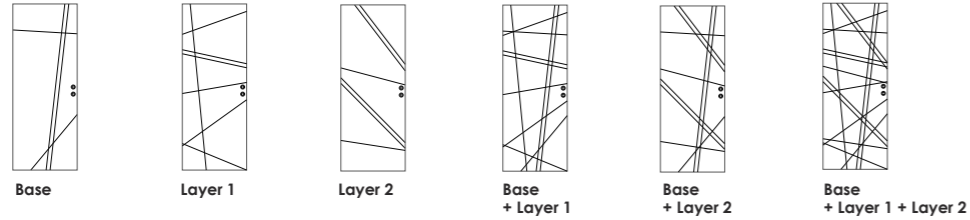

Fiumi

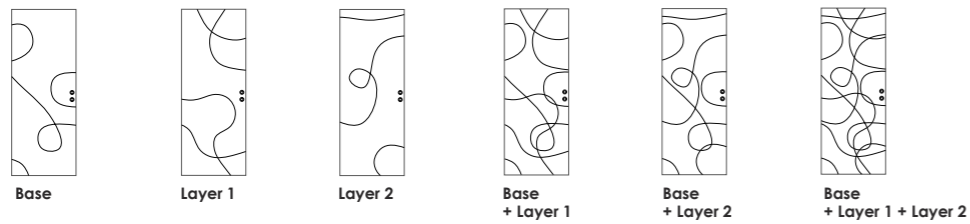

soluzioni di apertura *opening variant*

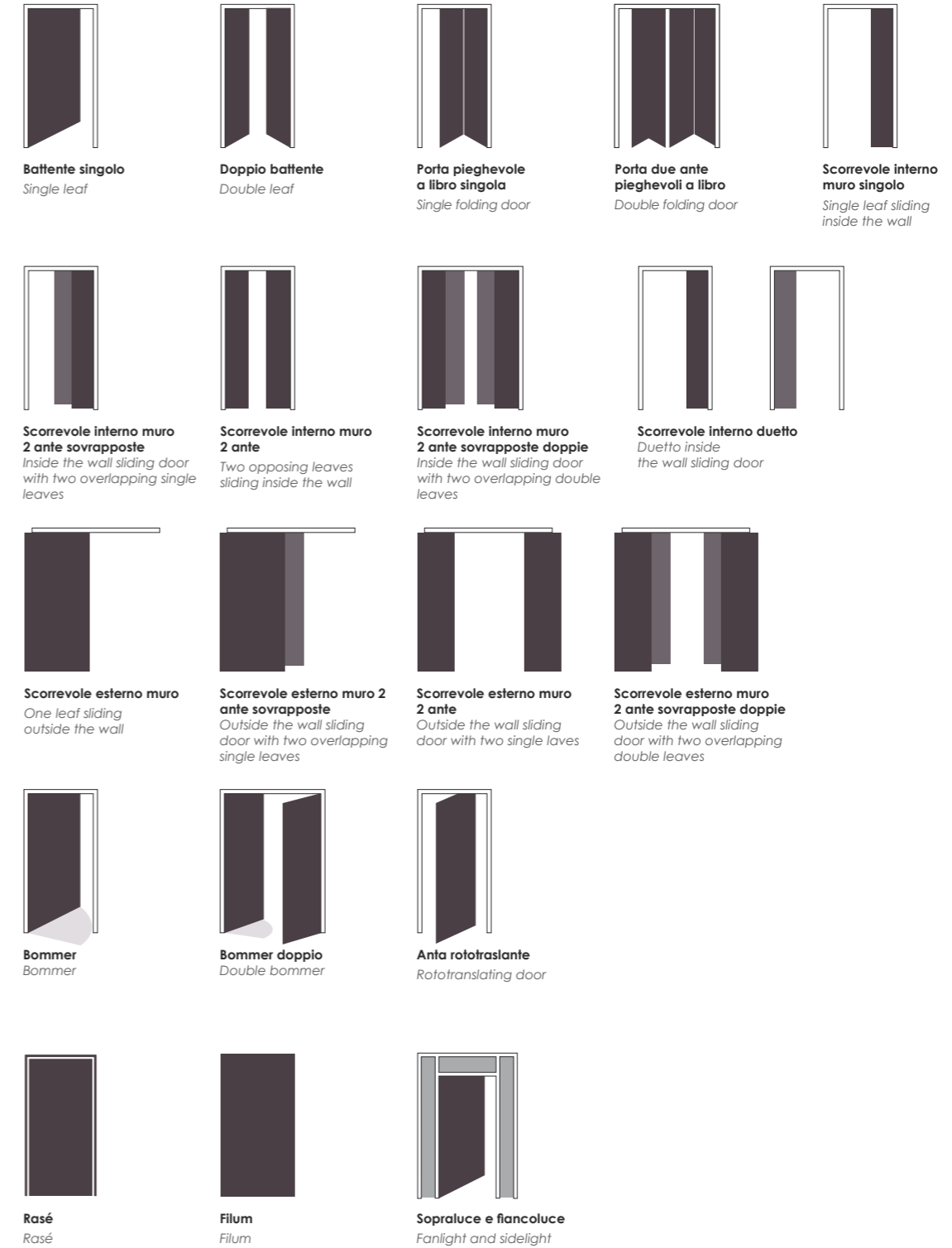

soluzioni telaio in legno *soluzioni telaio in legno*

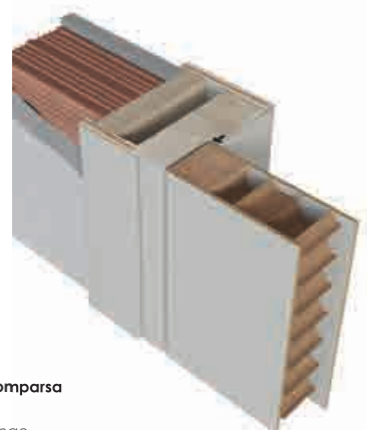

TELAIO STANDARD
con cerniera a scomparsa
Standard frame
with concealed hinge

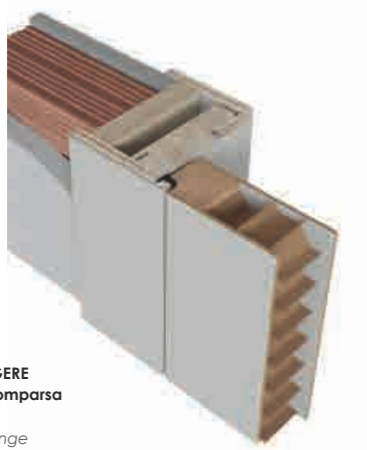

TELAIO RASÉ SPINGERE
con cerniera a scomparsa
PUSH RASÉ FRAME
with concealed hinge

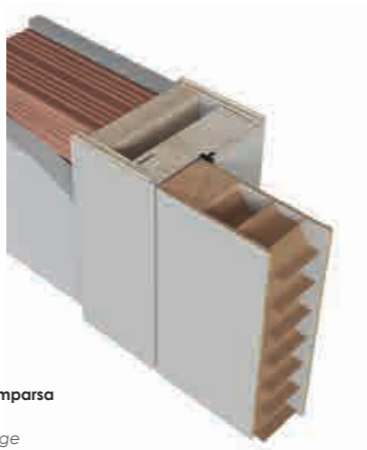

TELAIO RASÉ TIRARE
con cerniera a scomparsa
PULL RASÉ FRAME
with concealed hinge

soluzioni telaio in alluminio *aluminium frame solutions*

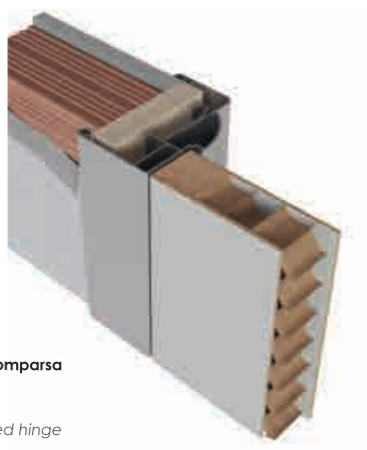

TELAIO ALUTECH
con cerniera a scomparsa
e/o a bandella
ALUTECH FRAME
with flap concealed hinge



TELAIO FILUM
con cerniera a scomparsa
FILUM FRAME
with concealed hinge

soluzioni telaio per porte tagliafuoco
frame solutions for fire doors

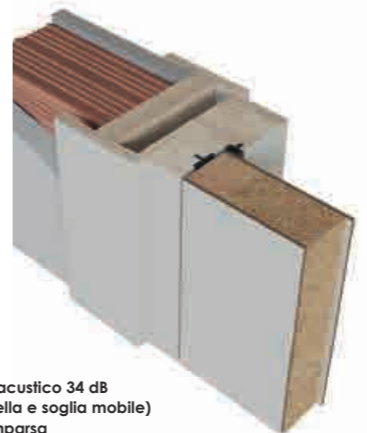

TELAIO EI30
con allestimento acustico 34 dB
(cerniere a bandella e soglia mobile)
e cerniere a scomparsa
EI30 FRAME
With sound-proofing fitting 34 dB
(flap concealed hinge and mobile
threshold) and with concealed hinge

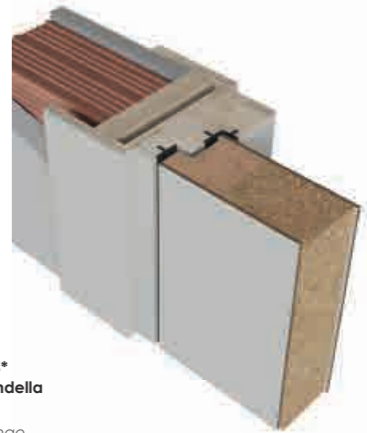

TELAIO EI60 - 37 dB*
con cerniera a bandella
EI60 FRAME 37 dB*
with concealed hinge

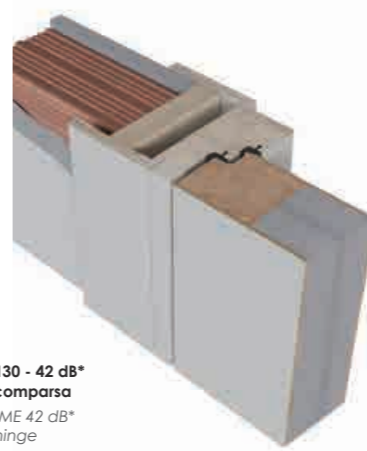

TELAIO D SUPER EI30 - 42 dB*
con cerniera a scomparsa
EI30 D SUPER FRAME 42 dB*
with concealed hinge

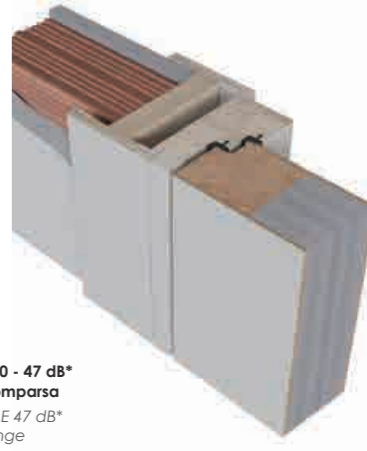

TELAIO D SUPER EI60 - 47 dB*
con cerniera a scomparsa
EI60 D SUPER FRAME 47 dB*
with concealed hinge

* Con allestimento acustico / With sound-proofing fitting



Resistenza all'umidità
Telaio in listellare resistente all'acqua
Resistance to moisture
Water resistant blockboard



Disponibile nelle versioni Opera
EI30 34dB/42dB e EI60 37dB/47dB
Available in Opera models
EI30 34dB/42dB and EI60 37dB/47dB



Sigillo di autenticità
Authenticity seal



Truciolare forato
Perforated chipboard



Truciolare lino pieno
Full flax chipboard



Serratura magnetica
Magnetic lock



Isolamento acustico
Sound insulation



Finitura coordinata per tutte le porte di casa,
rivestimento blindato e battiscopa
Matching panelling
for all your home doors



Cerniera a scomparsa
registrabile su tre assi
Concealed hinge
adjustable on three axis



essenze e colorazioni *wood types and colors*



Bianco B011
B011 White



Avorio B003
B003 ivory

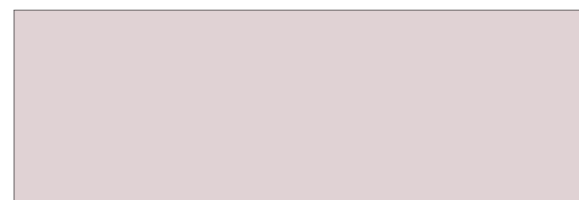

Violetta
Violet
NCS S 3005 - R 20B



Grigio Saturno
Saturn Grey
NCS S 3005 - Y 80R

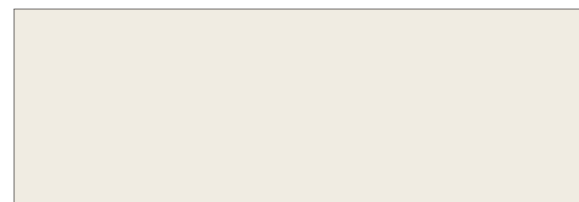

Terre d'Argilla
Clay dirt
NCS S 1002 - Y

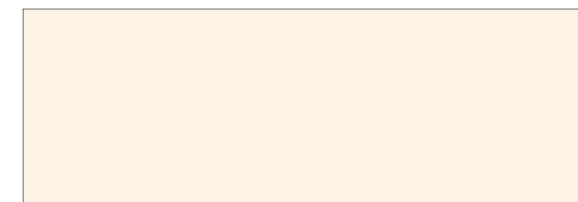

Corda
Rope
NCS S 1005 - Y 10R

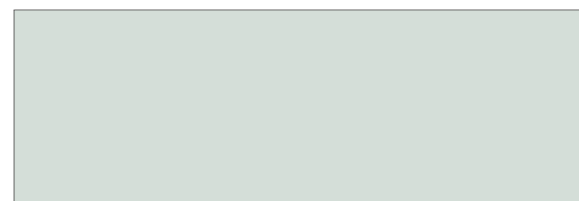

Ghiaccio
Ice
NCS S 1005 - G

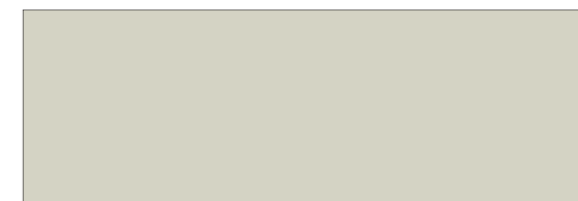

Grigio Tortora
Dove Grey
NCS S 3005 - G 80Y

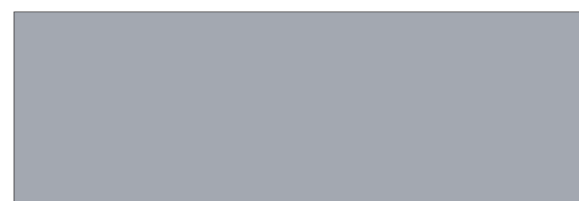

Grigio Dierre
Dierre Grey

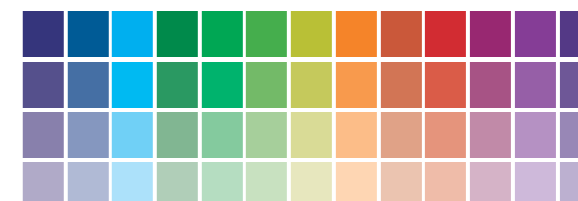

RAL* / NCS

* Vedere campionario RAL per codifica colore / See RAL sample for colour coding

LIGHT



LIGHT

La collezione Light ripropone in chiave moderna le linee classiche delle porta tradizionali a bugna con una pantografatura quadrata piana. Segno delicato che si abbina alla perfezione con le nuove finiture d'arredo Portedi selezionate NCS, offrendo superfici morbide e caldi riflessi.

The Light collection presents a more modern version of classic lines found in traditional raised panel doors with a flat square pantographing. A delicate touch that perfectly matches with the new Portedi NCS selected furnishing finishes, offering soft surfaces and warm reflections.



Telaio listellare e coprifili in multistrato da 6,5 cm con alette telescopiche da 2 cm

The block board frame and the multilayer casing and 6.5 cm with 2 cm telescopic tabs



Serratura meccanica centromediana con scrocco in teflon antirumore

Mechanical lock with noise-proof teflon latch

Serratura libero/occupato minimale della versione scorrevole Minimal lock of the sliding version

Particolare linguetta di trascinamento Sliding tab detail

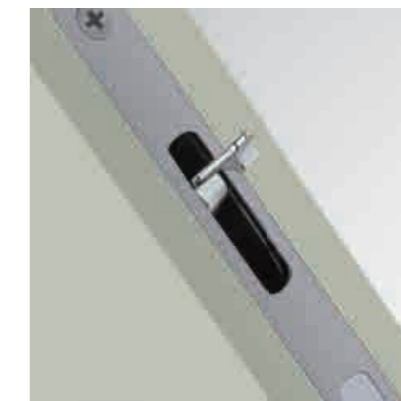

Sigillo di autenticità Authenticity seal

Particolare di anubatura tra anta e telaio e cappucci copricerniera Anuba hinges detail between wing and frame and hinge cover caps





Versione Light Y
Colore Grigio Saturno
Coprifilo M90/T90 taglio a 90° lineare
Variant Light Y
Colour Saturn Grey
Cover mould M90/T90 with 90° cut



Versione Light R 2
Colore Terre d'Argilla
Coprifilo M90/T90 taglio a 90° lineare
Variant Light R 2
Colour Clay Dirt
Cover mould M90/T90 with 90° cut





**Disponibile nelle versioni Opera
E130 34dB/42dB e E160 37dB/47dB**
*Available in Opera models
E130 34dB/42dB and E160 37dB/47dB*



Sigillo di autenticità
Authenticity seal



Truciolare forato
Perforated chipboard



Truciolare lino pieno
Full flax chipboard



Serratura magnetica
Magnetic lock



Isolamento acustico
Sound insulation



**Finitura coordinata per tutte le porte di casa,
rivestimento blindato e battiscopa**
*Matching panelling
for all your home doors*



**Cerniera a scomparsa
registrabile su tre assi**
*Concealed hinge
adjustable on three axis*

soluzioni telaio in legno *soluzioni telaio in legno*

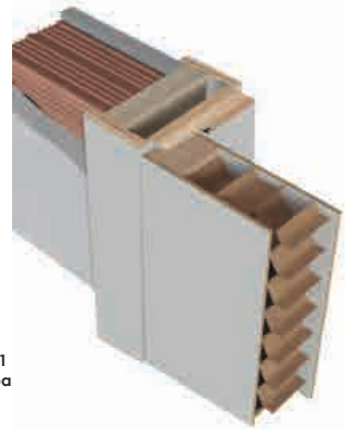

TELAIO STANDARD 1
con cerniera Anuba
Special frame
with Anuba hinge

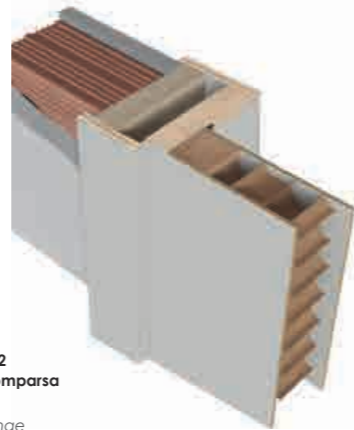

TELAIO STANDARD 2
con cerniera a scomparsa
Special frame
with concealed hinge

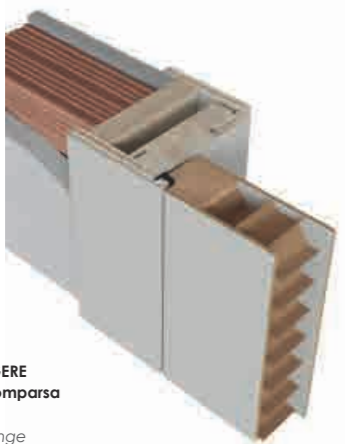

TELAIO RASÉ SPINGERE
con cerniera a scomparsa
PUSH RASÉ FRAME
with concealed hinge

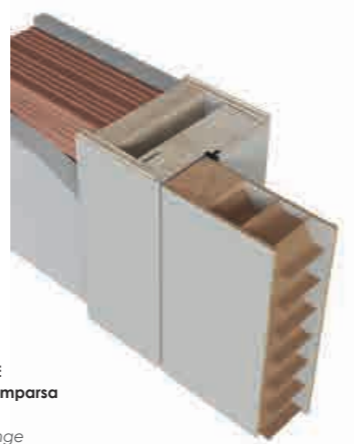

TELAIO RASÉ TIRARE
con cerniera a scomparsa
PULL RASÉ FRAME
with concealed hinge

soluzioni telaio in alluminio *aluminium frame solutions*

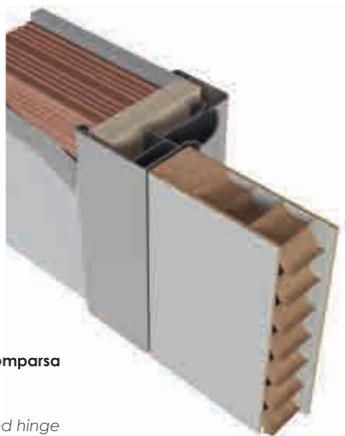

TELAIO ALUTECH
con cerniera a scomparsa
e/o a bandella
ALUTECH FRAME
with flap concealed hinge

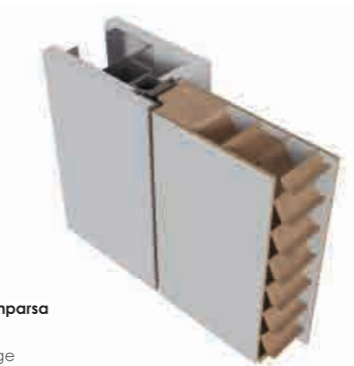

TELAIO FILUM
con cerniera a scomparsa
FILUM FRAME
with concealed hinge

soluzioni telaio per porte tagliafuoco
frame solutions for fire doors

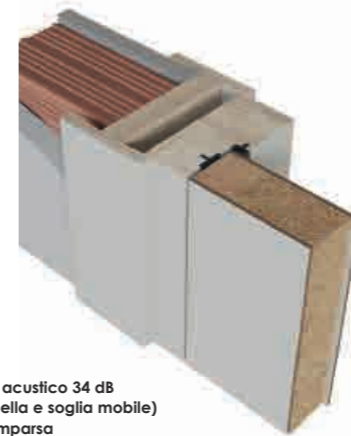

TELAIO EI30
con allestimento acustico 34 dB
(cerniere a bandella e soglia mobile)
e cerniere a scomparsa
EI30 FRAME
With sound-proofing fitting 34 dB
(flap concealed hinge and mobile
threshold) and with concealed hinge

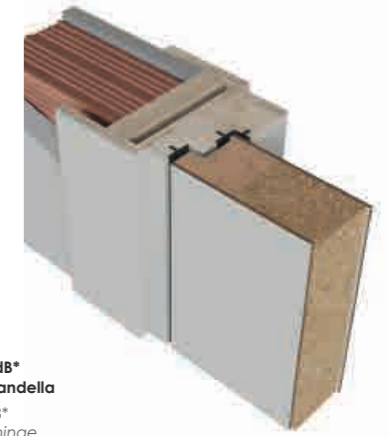

TELAIO EI60 - 37 dB*
con cerniera a bandella
*EI60 FRAME 37 dB**
with concealed hinge

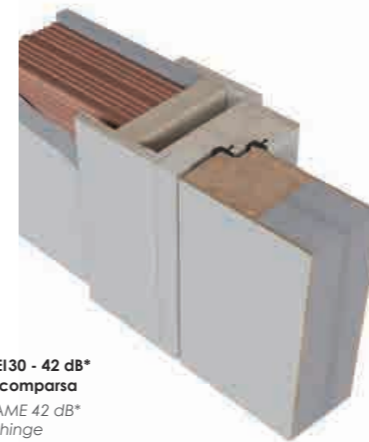

TELAIO D SUPER EI30 - 42 dB*
con cerniera a scomparsa
*EI30 D SUPER FRAME 42 dB**
with concealed hinge

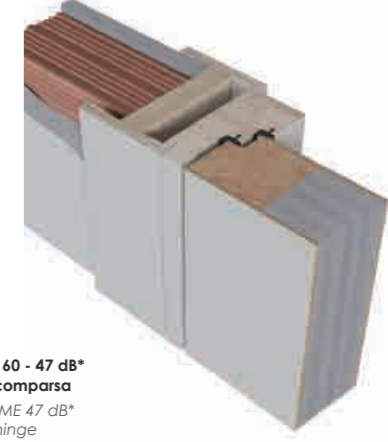

TELAIO D SUPER EI60 - 47 dB*
con cerniera a scomparsa
*EI60 D SUPER FRAME 47 dB**
with concealed hinge

* Con allestimento acustico / *With sound-proofing fitting*

allestimenti lines

LIGHT

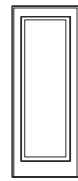

Light 1



Light 2



Light Y



Light J
a 3 riquadri
with 3 sections



Light L
a 3 riquadri
with 3 sections



Light J
a 4 riquadri
with 4 sections



Light L
a 4 riquadri
with 4 sections

LIGHT R

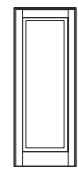

Light 1 R

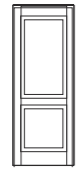

Light 2 R

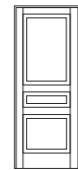

Light Y R

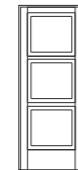

Light J R
a 3 riquadri
with 3 sections

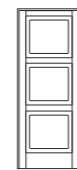

Light L R
a 3 riquadri
with 3 sections

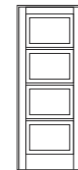

Light J R
a 4 riquadri
with 4 sections



Light L R
a 4 riquadri
with 4 sections

soluzioni di apertura opening variant

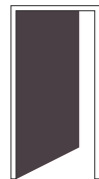

Battente singolo
Single leaf



Doppio battente
Double leaf



Porta pieghevole
a libro singola
Single folding door



Porta pieghevole
doppia
Double folding door



Bommer
Bommer



Bommer doppio
Double bommer



Rasé
Rasé

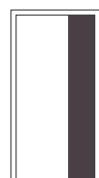

Scorrevole interno
muro singolo
Single leaf sliding
inside the wall

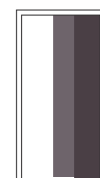

Scorrevole interno muro
2 ante sovrapposte
Inside the wall sliding
door with two
overlapping single leaves



Scorrevole interno muro
2 ante
Two opposing
leaves sliding inside
the wall



Scorrevole interno muro
2 ante sovrapposte doppie
Inside the wall sliding door
with two overlapping dou-
ble leaves



Scorrevole interno duetto
Duetto inside
the wall sliding door



Filum
Filum

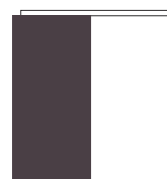

Scorrevole esterno muro
One leaf sliding
outside the wall

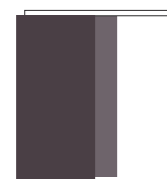

Scorrevole esterno muro 2
ante sovrapposte
Outside the wall sliding
door with two overlapping
single leaves



Scorrevole esterno muro
2 ante
Outside the wall sliding
door with two single laves

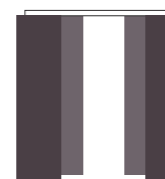

Scorrevole esterno muro
2 ante sovrapposte doppie
Outside the wall sliding
door with two overlapping
double leaves

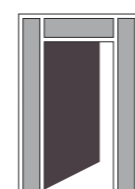

Sopraluce
e fiancoluce
Fanlight
and sidelight



Trapezoidale
Slanted door

essenze e colorazioni wood types and colors



Bianco B011
B011 White



Avorio B003
B003 ivory



Violetta
Violet
NCS S 3005 - R 20B



Grigio Saturno
Saturn Grey
NCS S 3005 - Y 80R

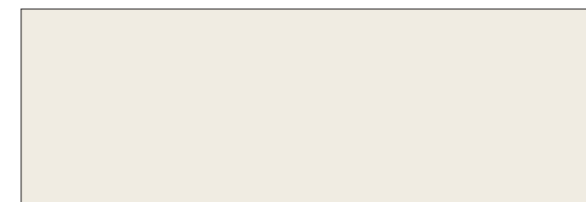

Terre d'Argilla
Clay dirt
NCS S 1002 - Y

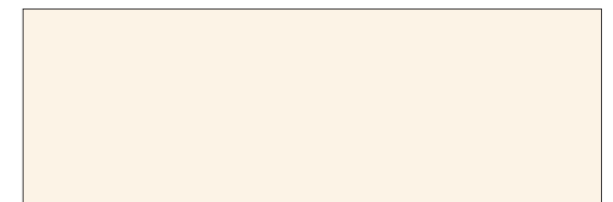

Corda
Rope
NCS S 1005 - Y 10R



Ghiaccio
Ice
NCS S 1005 - G

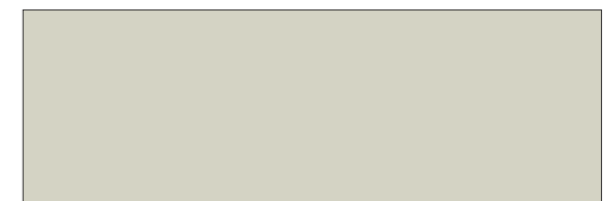

Grigio Tortora
Dove Grey
NCS S 3005 - G 80Y

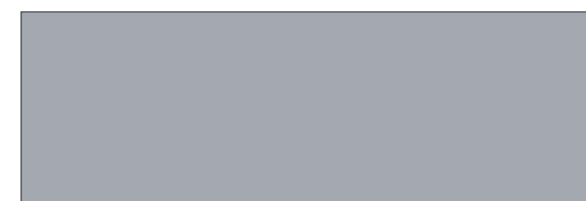

Grigio Dierre
Dierre Grey

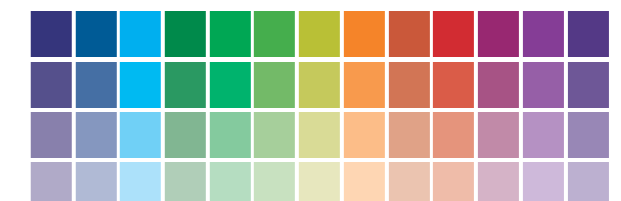

RAL* / NCS

* Vedere campionario RAL per codifica colore / See RAL sample for colour coding

SILENCE



Silence raso muro modello Light 1 RAL 5011, maniglia Dallas cromo satinato
Silence raso muro Light 1 model RAL 5011, Dallas handle chrome satin

SILENCE

Ideale per chi vuole proteggere l'accesso alla camera da letto, Silence è la porta blindata che unisce le prestazioni di una chiusura di sicurezza per esterni con lo stile e la discrezione di una porta per interni. Sicura, versatile ed elegante, le soluzioni estetiche sono quelle suggestive e sconfinata della collezione Dierre di porte interne per una relazione armonica tra i diversi spazi. La maniglia, dotata di uno sblocco di sicurezza, può essere regolata alla stessa altezza delle altre presenti in casa. Disponibile nelle due versioni: predisposta per imbotte e raso muro.

The ideal solution for those wishing to protect access to the bedroom, Silence is the security door that combines the performance of an outdoor security door with the style and discretion of an interior door.

Secure, versatile and elegant, the aesthetic solutions are those suggestive and boundless of the Dierre collection of interior doors for a balanced combination of different spaces. The handle, equipped with a security release, can be adjusted to the same height as the others in the house. Available in two versions: for casing and flush to the wall.



Le cerniere non sono a vista, ma nascoste dal telaio e dall'anta stessa. Inoltre sono regolabili sui 3 assi e permettono l'apertura del battente a 180°.

The hinges are not exposed, but hidden by the frame and the leaf itself. Furthermore they can be adjusted on the 3 axes and allow the 180° opening of the leaf.



Perfettamente complanare alla parete, il telaio è realizzato con uno speciale profilo in alluminio e può essere murato o ancorato ad una struttura preesistente in legno.

Perfectly flush to the wall, the frame is made with a special aluminium profile and can be bricked-in or anchored to a pre-existing wooden structure.



Con uno spessore di cinquantasette millimetri e tre rostri fissi antisfondamento, Silence è una vera e propria porta di sicurezza, che preserva inalterata l'eleganza di una porta da interni. L'anima del battente realizzata in doppia lamiera, certificata in classe 3 antintrusione ENV1627, è dotata di soglia mobile (lamina parafreddo), che garantisce protezione da spifferi e luce.

57 millimetres thick and with three wrench-proof fixed grips, Silence is a true security door that preserves the elegance of an internal door. The double sheet core of the leaf, certified burglar-proof in class 3 ENV1627, is equipped with a mobile sill (cold-excluding sill), which guarantees protection from drafts and light.



Serratura di serie in versione mezzo cilindro, a tre catenacci e scrocco, con deviatore Hook inferiore ed asta superiore. Il cilindro visibile solo su lato esterno. Per chiudere la porta dall'interno, basta sollevare la maniglia e abbassare la stessa, per riaprirla. Per chiudere la porta dall'esterno basta sollevare la maniglia, mentre per riaprirla è necessario utilizzare la chiave.

Standard lock in the half cylinder version, with three bolts and latch, with lower Hook deviator and upper rod. The cylinder is only visible on the outer side. To lock the door from the inside, simply lift the handle and lower it to reopen it. To close the door from the outside lift the handle, while to reopen it you must use the key.

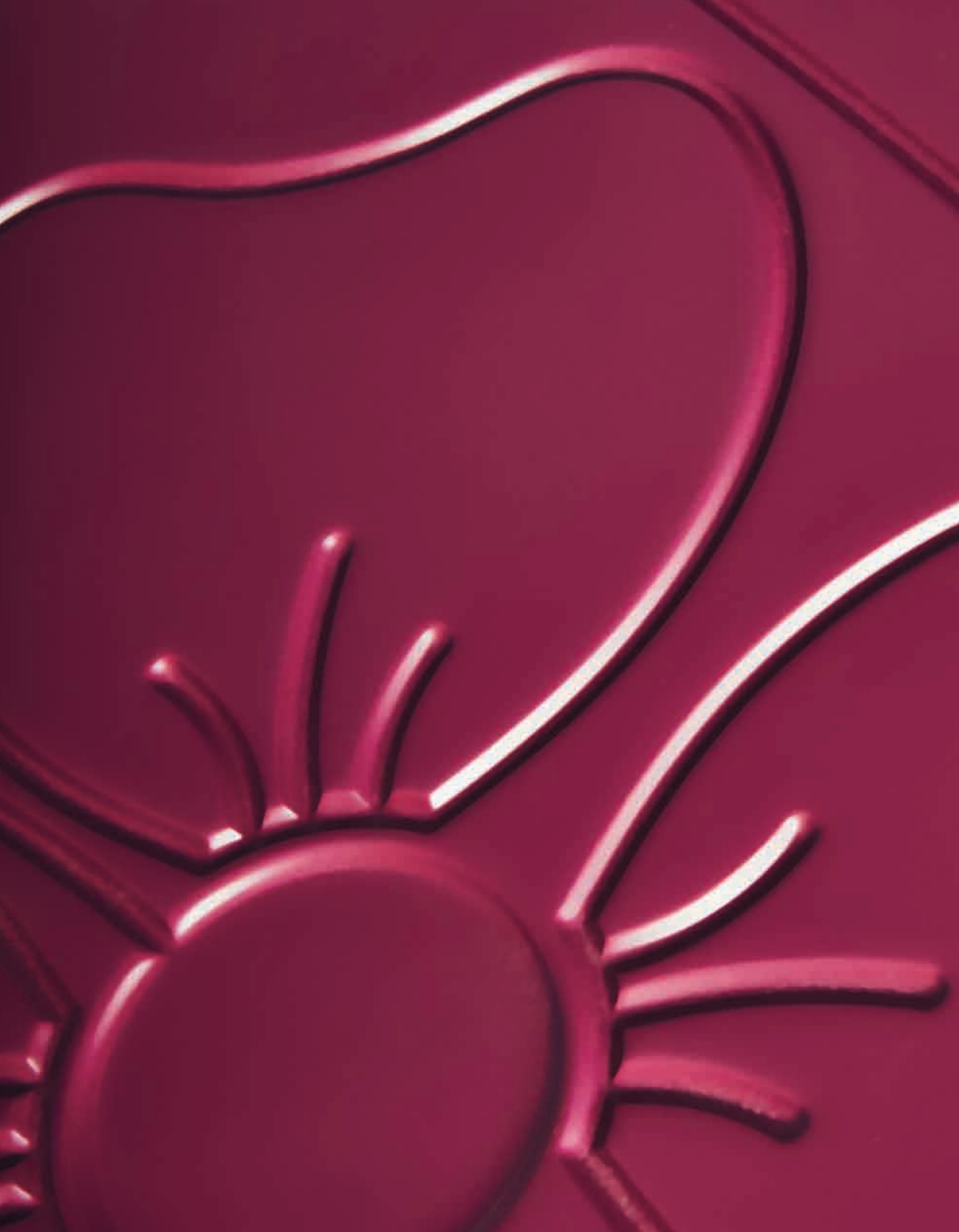



Dierre Spa
Strada statale per Chieri 66/15
14019 Villanova D'Asti (At)
Tel 0141.949411
info@dierre.it

www.dierre.com