

Product Overview

www.minimal-windows.com

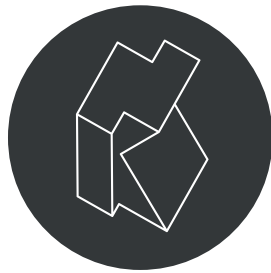



About us

Keller minimal windows® is a worldwide leading designer and manufacturer of innovative, high-quality, and almost frameless aluminum window and door systems.

Our success is based on 15 years of experience in the luxury segment. We develop tailor-made solutions that bring architectural visions to life all over the world. Our goal is to achieve perfection and meet the most extreme and demanding requirements. We strive to push architectural boundaries while providing reliable and long-lasting functionality.

Although we offer global service, we firmly believe that a personal touch is essential for success. We have

maintained the flexibility of a small company. All our products are individually designed and manufactured in our production facility in Luxembourg, in the heart of Europe.

Assembly is carried out by our exclusive network of trained and qualified partners on various continents. The dedicated product team of Keller minimal windows® strives to understand both your requirements and your vision. We always deliver tailor-made solutions perfectly aligned with your projects and the markets you serve.



minimal windows®

Enter a world of limitless light and outstanding views with our minimal windows® double glazing system. With an elegant sash profile of just 21 mm, our aluminum windows redefine contemporary luxury and offer expansive views with virtually invisible frame profiles.

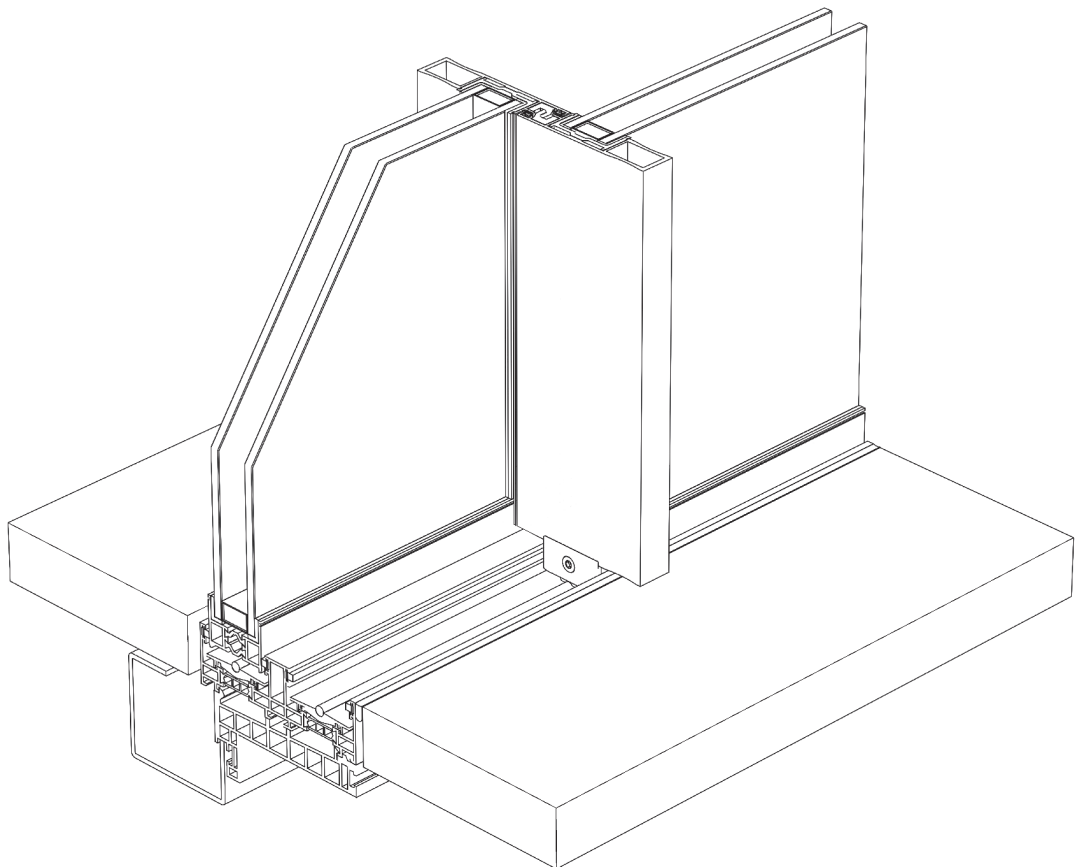

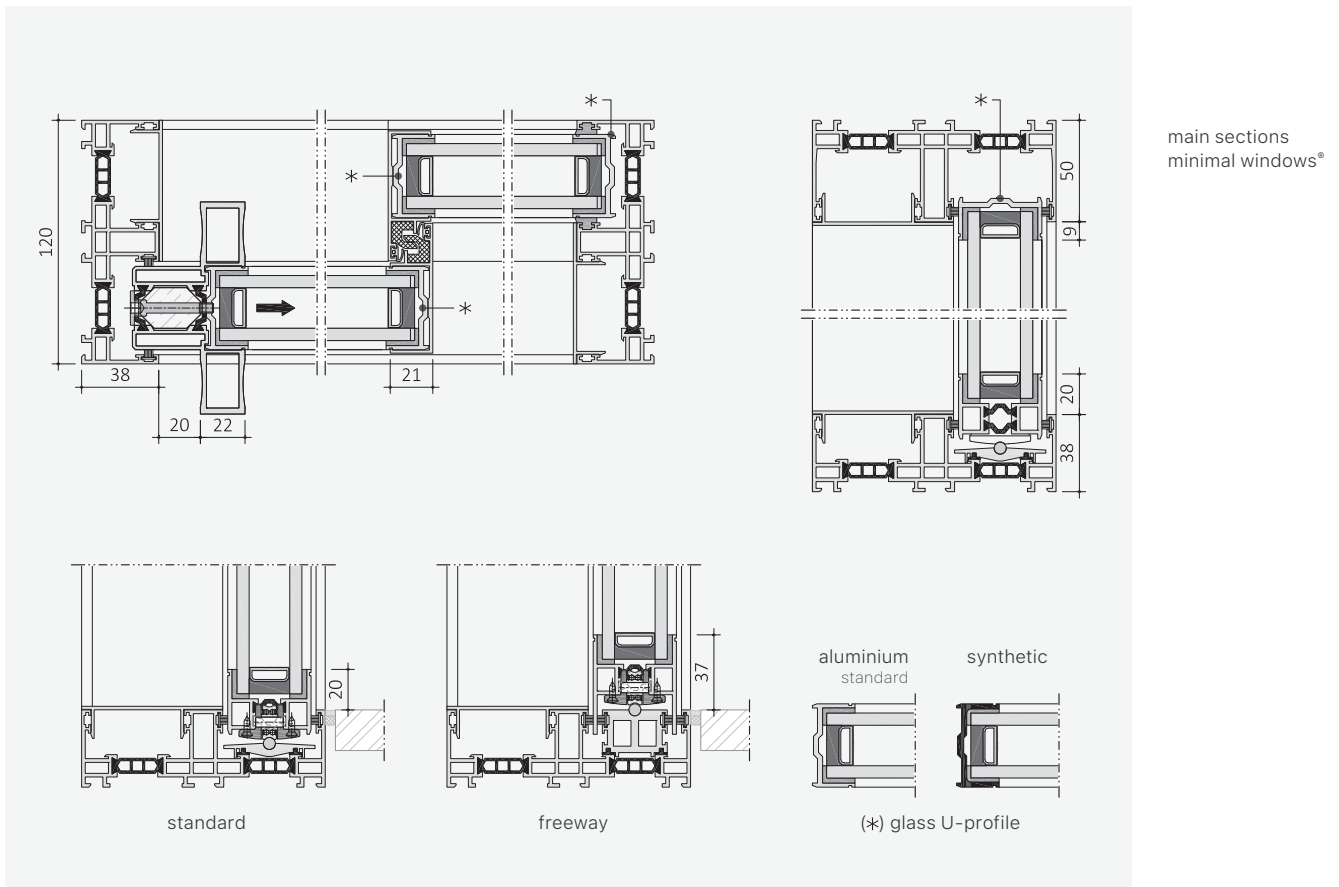

Minimalist design takes center stage in contemporary architecture. With clean lines, balanced proportions and a focus on natural light, our minimal windows® system elevates any space, from exclusive villas to commercial projects.

With over 15 years of meticulous development, we have perfected the art of the concealed floor track and ensure effortless operation of our sliding elements. Enjoy the perfect synergy of form and function, where architectural elegance meets unparalleled ease of use.

Thanks to their narrow width, our aluminum frame profiles almost disappear visually and emphasize the minimalist elegance of our minimal windows®. With a limitless choice of placement options, from mullion-free internal or external corners to reversible units, all-glass corners and wall pockets where the unit disappears completely into the wall, our system offers maximum flexibility to meet any design preference. Choose from a wide range of colors and textures, including matte, gloss or powder-coated finishes to perfectly match your space.

minimal windows®

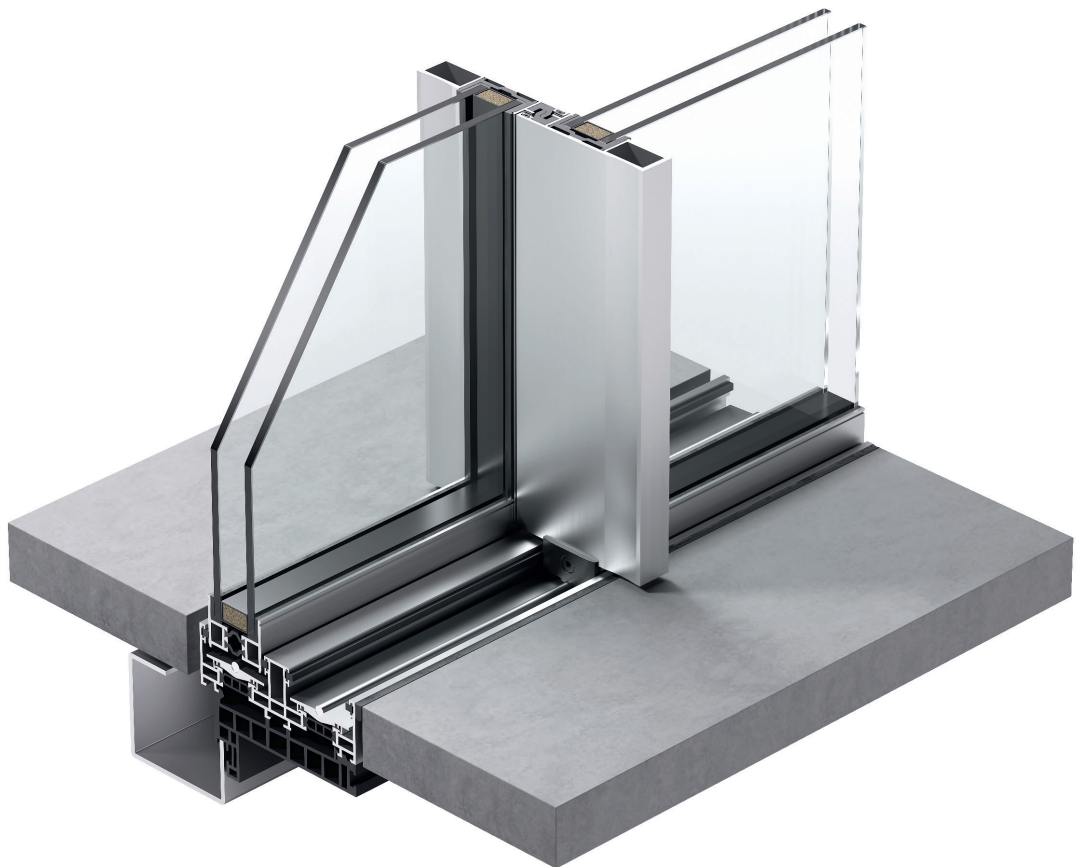



system

facing width	21 mm	max. numbers of tracks	up to 5 tracks
installation flush to the floor	possible	overall insulation glass thickness	26 up to 34 mm
installation flush to the ceiling	possible	automated sliding leaf	yes
max. leaf height	4 m	motorisation	up to 2400 kg total weight with one motor and combined leaves
min. W/H	1/3	accessibility	DIN 18040-1, DIN 18040-2
max. leaf weight	500 kg		
max. leaf area sliding	8 m ²		
max. leaf area fix	18 m ²		

building physics

Uw-Values (depending on glass type & dimensions)	≥1,1 W/(m ² K)	
air permeability	up to class 4	EN 12207
resistance to rain penetration	up to class 7A	EN 12208
resistance to wind loads	up to class C4/B5	EN 12210
sound insulation	up to 39 dB	ISO 717-1

safety

resistance to burglary	up to RC 2	EN 1627
------------------------	------------	---------

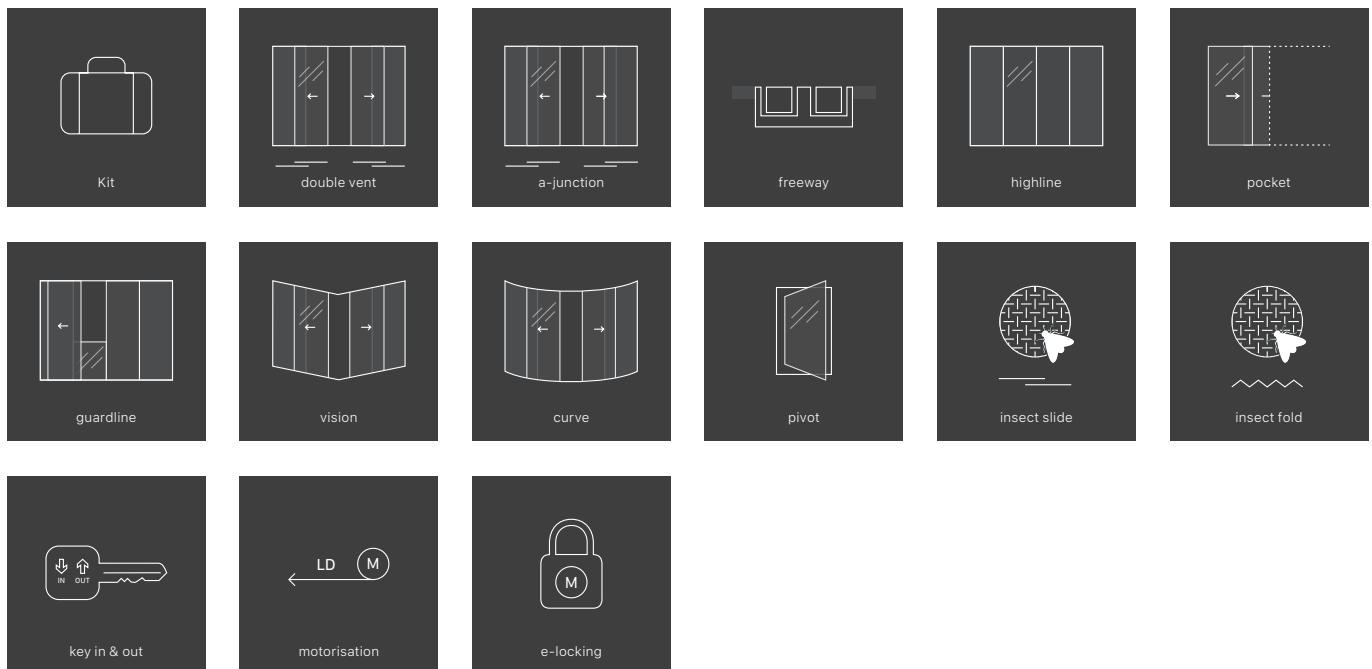

minimal windows®

4+

Our product range embodies the essence of minimalist design by combining simplicity with functionality and comfort. Our minimal windows®4+ is characterized by the integration of triple-glazed premium windows, available as sliding or fixed units, perfect for creating expansive glass façades. These windows not only flood interiors with natural light, but also open up unobstructed views of nature and seamlessly merge indoor and outdoor areas.

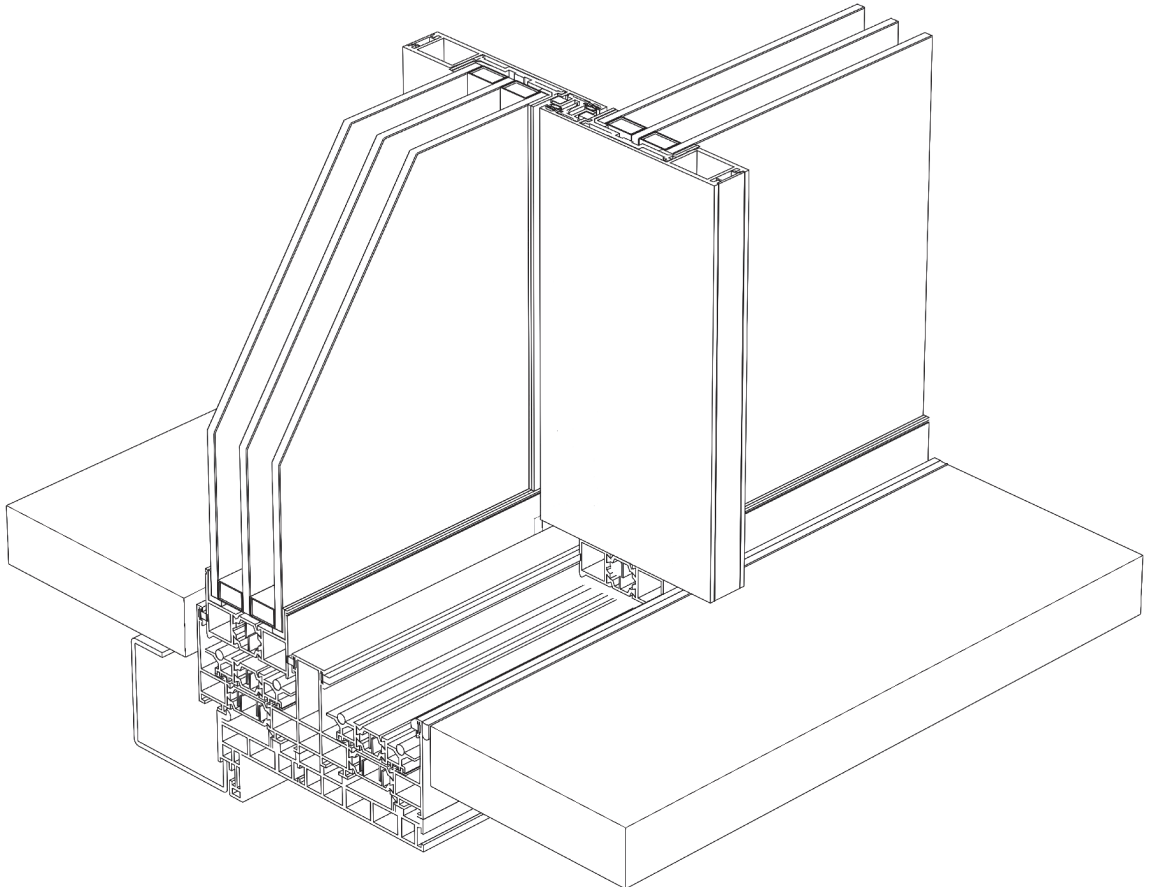

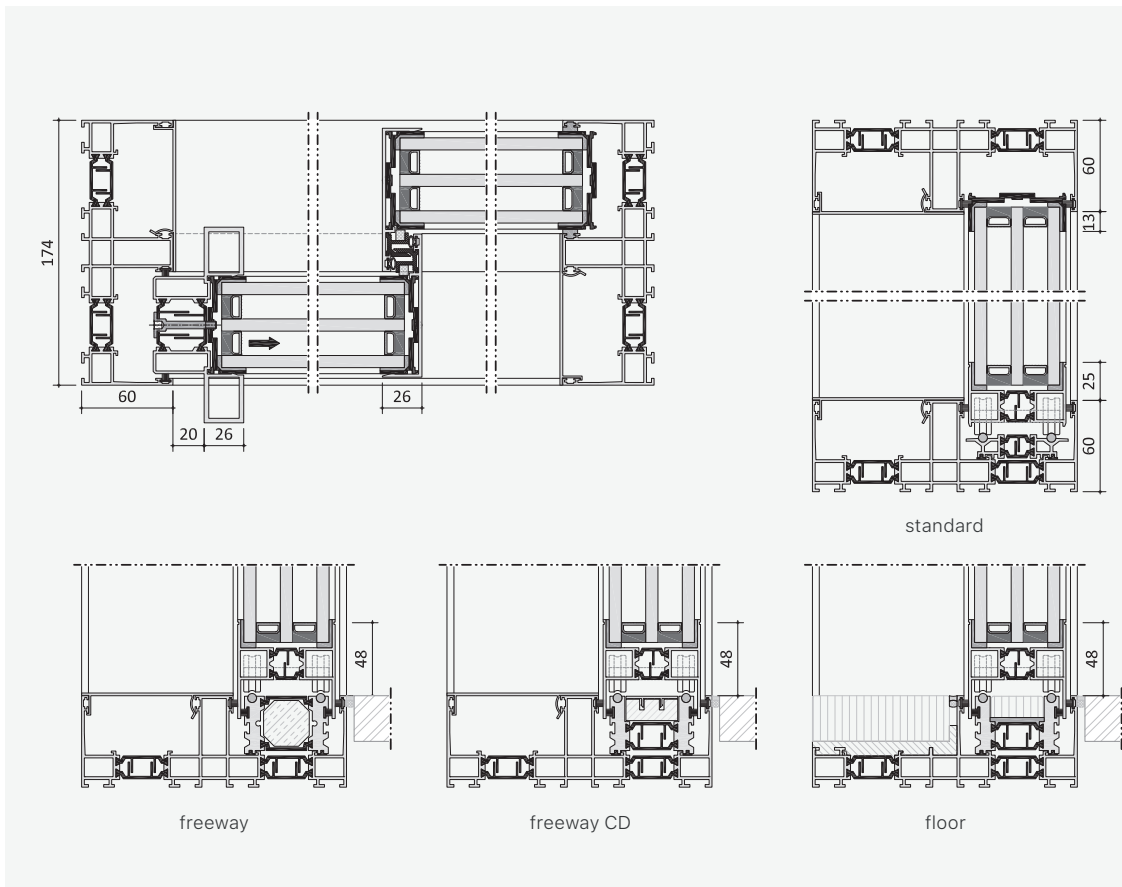

main sections
minimal windows® 4+

Architects can unleash their creativity with our products, as the 4+ enables oversized glass surfaces with heights of up to 6 meters and a weight of up to 1,000 kg per sash. In line with the latest energy-efficient building standards, our solutions are suitable for low-energy and passive houses.

In combination with high-quality insulating glass, our 4+ system enables U_w values of ≥ 0.70 W/m²K and therefore considerable energy savings. In addition, our aluminum frames are designed to withstand strong wind loads while maintaining their slimline elevations of just 26 to 34mm. The minimalist frame profiles integrate seamlessly into floors, ceilings or walls.

At Keller minimal windows, we offer architects, contractors and homeowners a wide range of design options. From mullion-free inner or outer corners to pivot units and all-glass corners, our products offer endless possibilities.

For those looking for an even more seamless transition between interior and exterior spaces, our sliding units can disappear into specially designed wall pockets to create unrestricted views and unparalleled aesthetics.

minimal windows®

4+

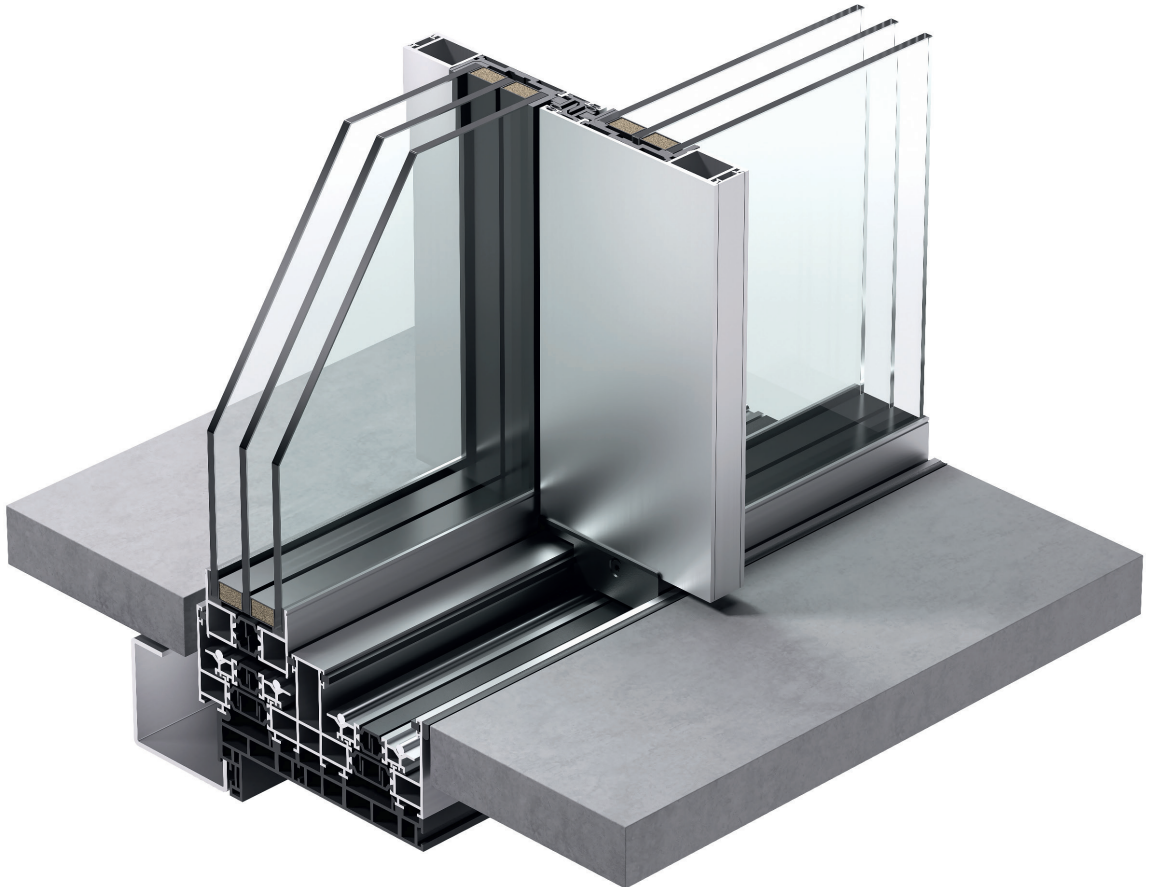



system

facing width	26/34 mm	max. numbers of tracks	up to 5 tracks
installation flush to the floor	possible	overall insulation glass thickness	40 up to 56 mm
installation flush to the ceiling	possible	automated sliding leaf	yes
max. leaf height	4,5 m	motorisation	up to 2400 kg total weight with one motor and combined leaves
min. W/H	1/3	accessibility	DIN 18040-1, DIN 18040-2
max. leaf weight	1000 kg		
max. leaf area sliding	12 m ²		
max. leaf area fix	18 m ²		

building physics

Uw-Values (depending on glass type & dimensions)	≥0,7 W/(m ² K)	
air permeability	up to class 4	EN 12207
resistance to rain penetration	up to class 8A	EN 12208
resistance to wind loads	up to class C5	EN 12210
sound insulation	up to 43 dB	ISO 717-1

safety

resistance to burglary	up to RC 2	EN 1627
------------------------	------------	---------

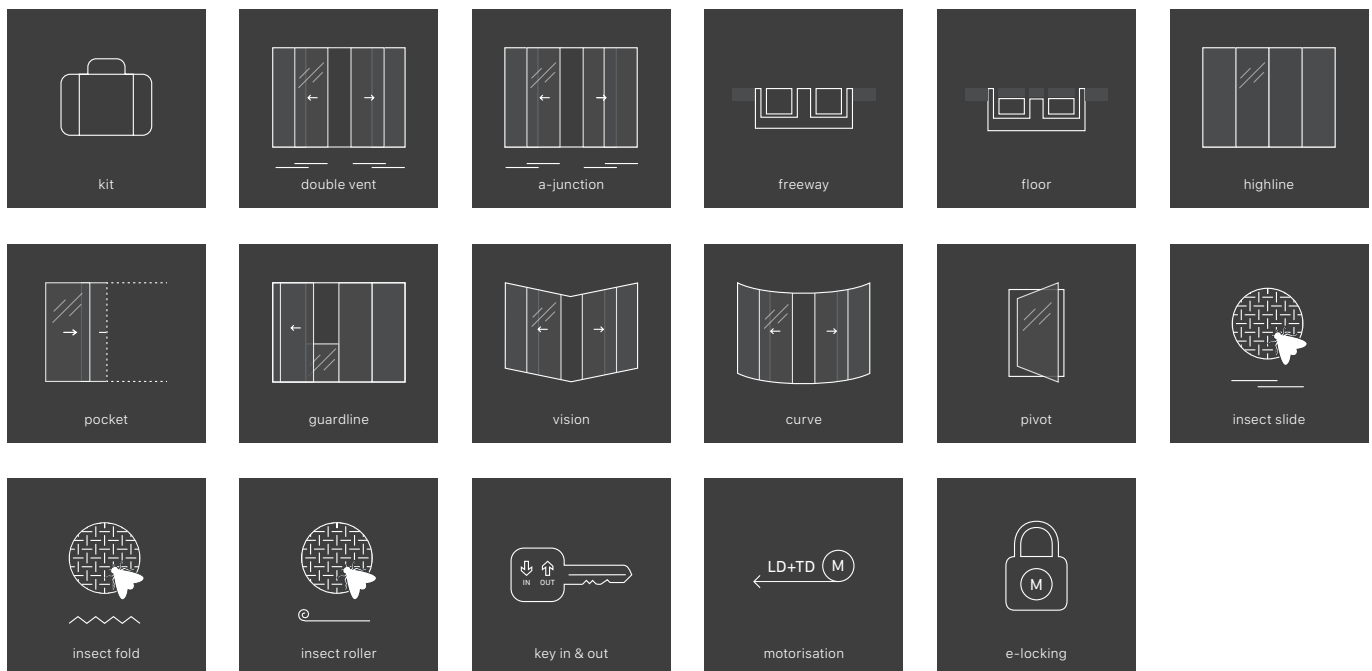

minimal windows® NGS

minimal windows® NGS enables a seamless transition between indoor and outdoor areas through barrier-free openings of entire window façades with heights of up to 6 meters and unlimited length options. Our expertise and continuous development over more than 15 years has enabled us to offer these customized solutions that provide maximum flexibility.

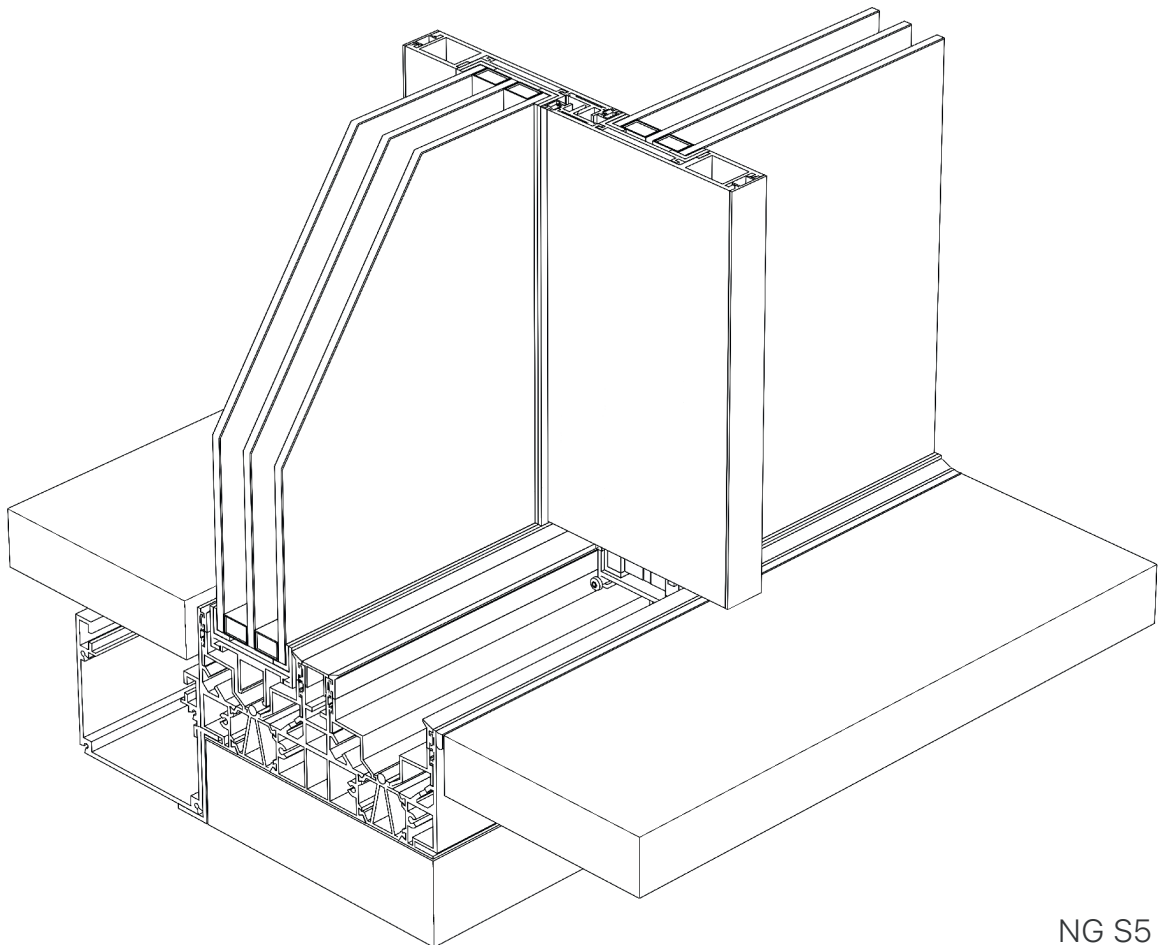

NG S5

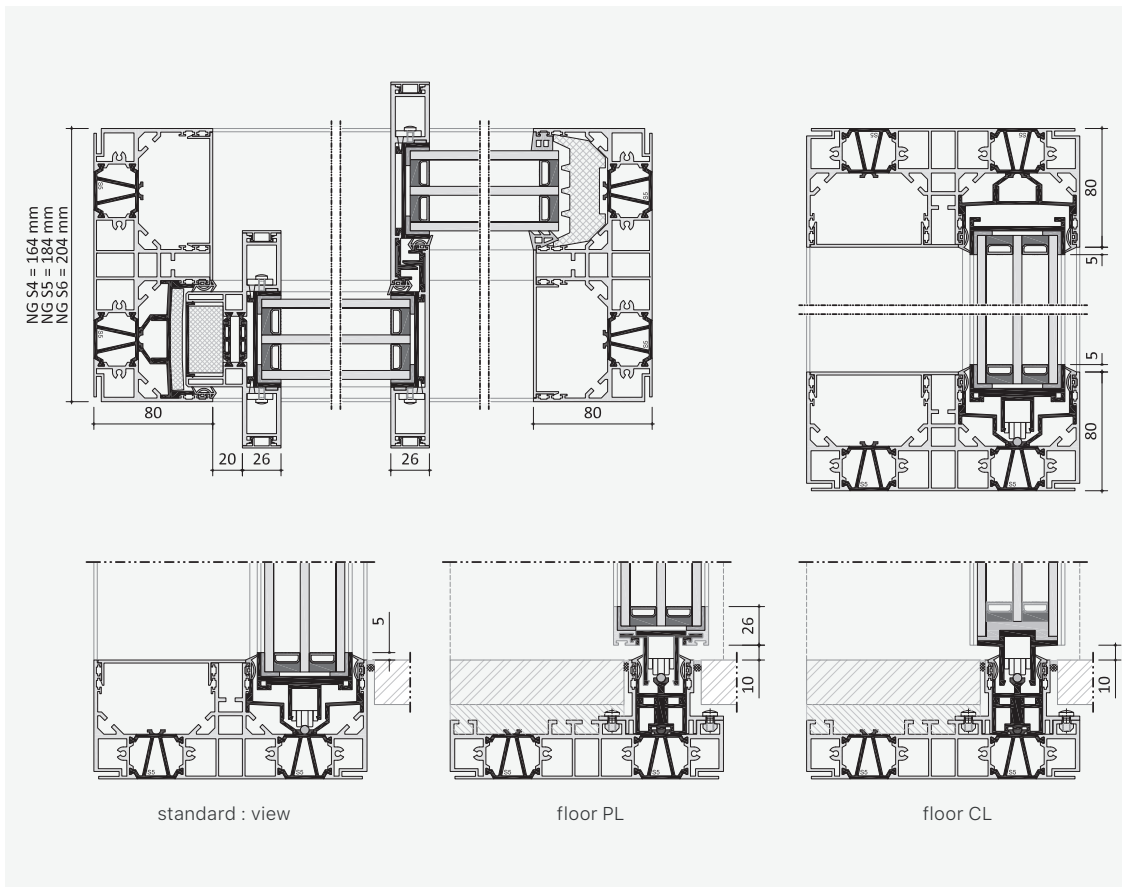

Our minimalist design allows for a harmonious combination of natural light and elegant aesthetics, promoting an inviting atmosphere for contemporary living. Light-flooded rooms with a maximum transparency of up to 99.3% create a unique, airy atmosphere in any home concept.

The advanced minimal windows® NGS system offers versatile design options, such as customizable glass thicknesses from 34 mm to 74 mm. The side profiles can be seamlessly integrated into walls, floors and ceilings to make them virtually invisible.

In addition, we offer motorization for opening and closing the sliding elements, which is capable of moving sash weights of up to 1,500 kg along the stainless steel track.

The possibilities offered by NGS provide limitless possibilities in the planning process and we are ready to turn your individual visions and requirements into reality.

minimal windows® NGS

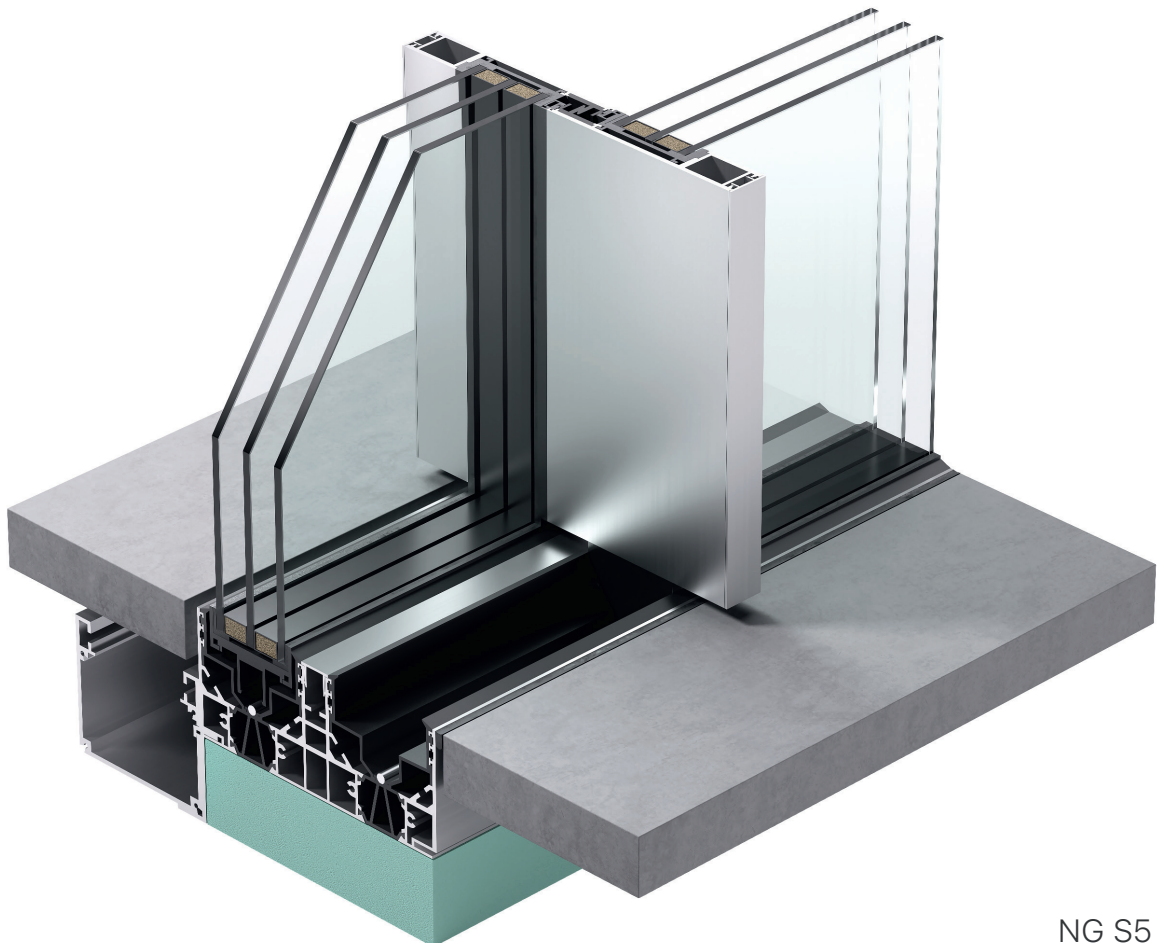

NG S5



system

facing width	26 mm	max. numbers of tracks	NG S4 : up to 5 tracks NG S5 : up to 4 tracks NG S6 : up to 4 tracks
installation flush to the floor	possible	overall insulation glass thickness	NG S4 : 34 up to 44 mm NG S5 : 44 up to 54 mm NG S6 : 54 up to 64 mm
installation flush to the ceiling	possible	automated sliding leaf	yes
max. leaf height	6 m	motorisation	up to 2400 kg total weight with one motor and combined leaves
min. W/H	1/3	accessibility	DIN 18040-1, DIN 18040-2
max. leaf weight	1500 kg		
max. leaf area sliding	18 m ²		
max. leaf area fix	18 m ²		

building physics

Uw-Values (depending on glass type & dimensions)	NG S4 ≥1,2 W/(m ² K) (a) NG S5 ≥0,95 W/(m ² K) (a) NG S6 ≥0,9 W/(m ² K) (a)	≥0,9 W/(m ² K) (b) ≥0,75 W/(m ² K) (b) ≥0,65 W/(m ² K) (b)
air permeability	up to class 4	EN 12207 (c)
resistance to rain penetration	up to class 8A	EN 12208 (d)
resistance to wind loads	up to class C5	EN 12210 (c)
sound insulation	up to 44/45/46 dB	ISO 717-1 (c)

safety

resistance to burglary	up to RC 3	EN 1627 (c) & PAS24
------------------------	------------	---------------------

(a) theoretical R&D calculation for sliding-fixe 6.0 x 6.0 m with glass Ug 1.0 W/m²K
 (b) theoretical R&D calculation for sliding-fixe 4.0 x 6.0 m with HM-glass Ug 0.6 W/m²K
 (c) target value, waitinWg for official testing
 (d) target value for drainage type 1 (target value for drainage type 2 & 3 >8A)

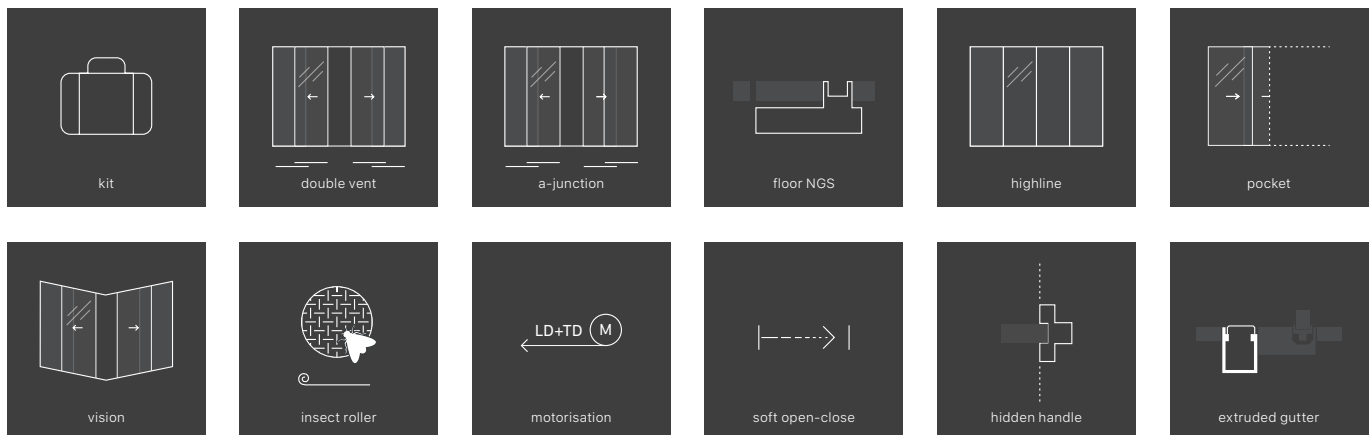





Showhouse

Photographer	mediashots
Partner	Group Ceyskens
Product	minimal windows® 4+

Showcasing uniqueness

Embark on a journey into the realm of modern architectural design and technology with Keller minimal windows® showcased in the stunning Showhouse of our Belgian partner Group Ceyskens. This architectural marvel skillfully combines contemporary, spacious interior design with expansive window facades that guarantee maximum light. Natural light floods the rooms, enhancing their warmth and inviting ambiance.

Uninterrupted views

At the heart of the Showhouse is a high-end swimming pool equipped with a movable pool floor for optimal use of space. Around the pool, an unobstructed panorama is created thanks to our minimal windows®, allowing indoor and outdoor spaces to flow effortlessly into one another - a demonstration of architectural finesse and seamless integration of design. The Group Ceyskens Showhouse symbolises progressive living, where cutting-edge technology meets sophisticated design.



Discover the fascinating story behind our project through an exclusive interview with Dirk Ceyskens. Simply scan the QR code to access the video directly.

System

	MW	MW4+	NG S4	NG S5	NG S6	NG S7
SHAPE						
sliding	●	●	●	●	●	⊖
highline	●	●	●	●	●	⊖
pivot	●	●	⊖	⊖	⊖	⊖
pivot entrance door	●	●	⊖	⊖	⊖	⊖
curve	●	●	○	○	○	⊖
vision	●	●	●	●	●	⊖
pocket	●	●	●	●	●	⊖
BOTTOM						
standard	●	●				
view			●	●	●	⊖
freeway	●	●				
freeway CD		●				
floor PL	○	●	●	●	●	⊖
floor CL			●	●	●	⊖
OPTIONS						
guardline	●	●				
key entrance	●	●	○	○	○	⊖
hidden handle bar			●	●	●	⊖
flush bar locking		●	●	●	●	⊖
MECHATRONIC						
smart slider LD	●	●	●	●	●	⊖
smart slider TD		●	●	●	●	⊖
soft open-close		○	○	○	○	⊖
e-lock	⊖	⊖	⊖	⊖	⊖	⊖
INSECT SCREENS						
protect slide	●	●				
protect fold	●	●				
protect roll		●	●	●	●	⊖

- AVAILABLE
- IN DEVELOPMENT
- ⊖ ON HOLD

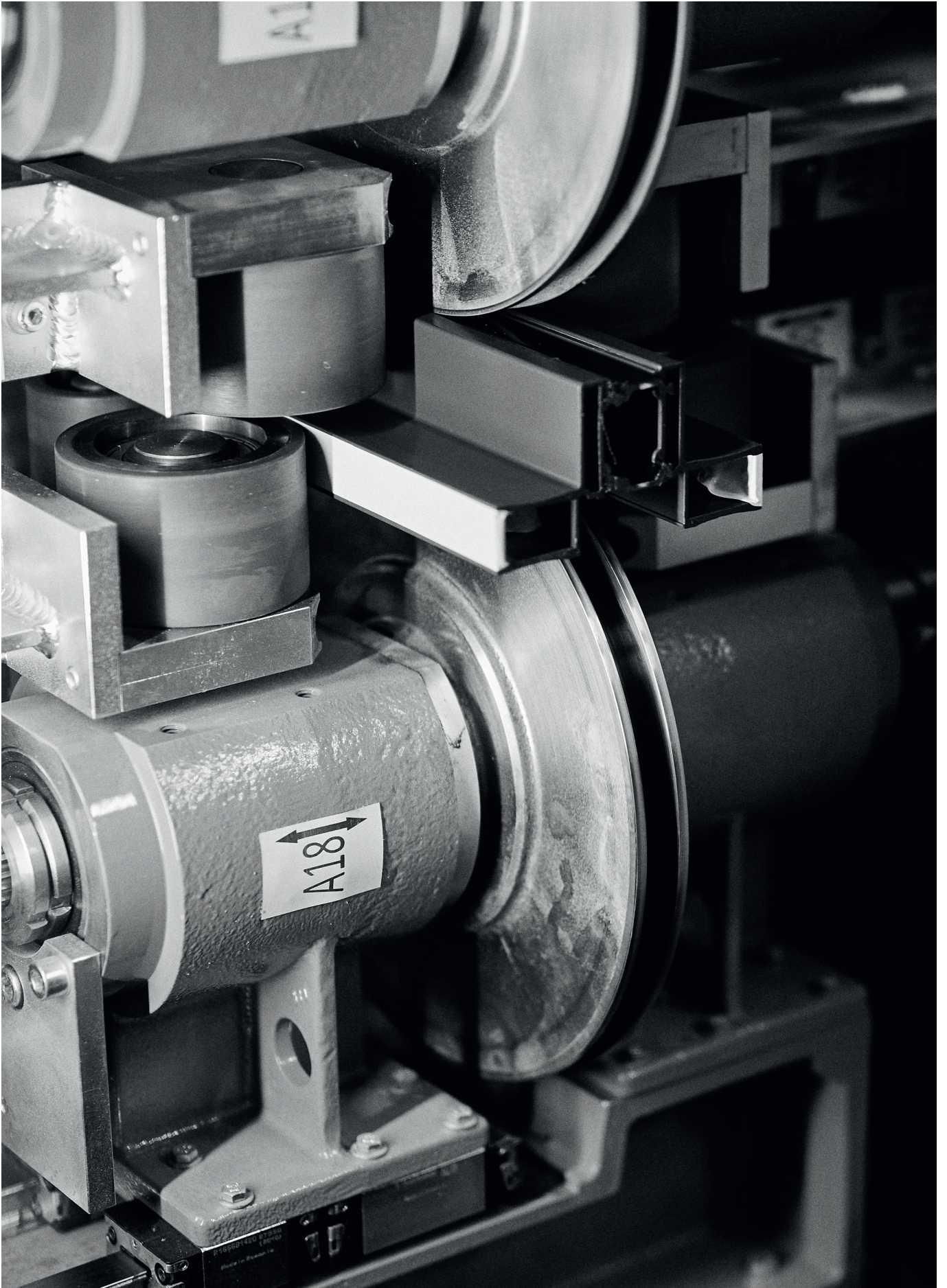



Keller Minimal Windows S.A.

38-40, route de Wilwerdange
9911 Troisvierges
LUXEMBOURG

Phone: +352 28 38 66 01
Email: info@keller-minimal-windows.com

www.minimal-windows.com