



SVK

**Experts in
fibre cement**



**TECHNICAL
DATA**

Ornimat ■ Decoboard ■
Puro Plus ■ Colormat

United Kingdom
Ireland

VERSION 1ST APRIL 2024

Content

Production	5
Technical characteristics	5
Physical characteristics	5
Durability	6
Weight	6
Reaction to Fire	6
Dimensions and tolerances	7
Finishing	8
Puro plus	8
Decoboard	8
Ornimat	9
Colormat	9
Guarantee	10
Quality	11
Puro Plus, Decoboard, Ornimat	11
Colormat	11
Transportation, storage and handling	12
Packaging and storage	12
Protection panel surface	13
Handling	13
Execution	14
Edge treatment	14
Cut to size panels	14
General tips for working	15
Drilling	15
Sawing	16
Protection and maintenance	17
Protection	17
Maintenance	17
Scope of application	18
Construction aspects of the ventilated facade	19

Advantages of a ventilated façade	19
Ventilation.....	19
Insulation	20
Moisture retention.....	21
Stability.....	21
Advantages of open horizontal joints	21
Execution - subframe.....	22
General	22
Timber subframe.....	23
Metal subframe	24
Execution façade panels.....	26
General	26
Intermediate distances fixings	28
Edge distance of the fixings	28
Diameter fixing holes	30
Visible fixing - screws on wood (system included in ETA)	30
Visible fixing –rivets on metal (system included in ETA)	31
Invisible fixing – anchors on metal (system included in ETA)	32
Invisible fixing – bonding system on wood or metal(system not included in ETA)	34
Execution ceiling	35
General	35
Intermediate distances fasteners (ceiling)	35
Edge distance fasteners (ceiling).....	35
List of reference documents	36
Principle section wooden substructure	38
Visible fixing on single wooden structure, mounted on support brackets.....	39
Visible fixing on single wooden structure – mounted on adjustable screws	41
Visible fixing on double wooden structure – directly on load-bearing structure	43
Invisible fixing on double wooden structure – bonding	45
Ceiling fixing – single wooden structure, mounted on support brackets.....	47
Principle section.....	48
Metal substructure	48
Fixing on metal substructure – rivets	49
Invisible fixing on metal substructure – with anchors	51
Connection details	53

Ventilation – air inlet bottom.....	53
Ventilation – air outlet top.....	54
Connection with other construction elements.....	55
Inner corner.....	56
Outer corner.....	57
Window finishing – lintel.....	58
Window finishing - sill.....	59
Cavity interruption.....	60
<u>Annex 1 – guide values for support- & fixing distances.....</u>	<u>62</u>
United kingdom.....	62
Ireland.....	65
<u>Annex 2 – Impact resistance.....</u>	<u>68</u>

The aim of these technical data is to provide information about the SVK façade cladding panels and how to install them. They do not relieve the executer of his responsibility concerning the application of the materials. SVK cannot be held responsible for mistakes made during manipulation and placement of the materials.

Details regarding the sub-frame, fasteners and other products / accessories are merely informative and not binding. We advise you to always gather information from the manufacturer or supplier of these products, and to follow their recommendations.

SVK façade cladding panels must always be installed in compliance with the national and/or local building regulations and guidelines. If these do not comply with the SVK guidelines, SVK must be contacted before the work starts.

Our product guarantee is only valid if the placement is executed following our most recent technical data. They are available on request or www.svk.be.

PRODUCTION

SVK façade panels are manufactured from a homogeneous mixture of Portland cement, selected process- and reinforcement fibres, additives and water. The mixture is transmitted in thin layers under constant pressure to a format roller by means of a sieve cylinder machine (Hatschek) until the required panel thickness is obtained.

Ornimat, Decoboard and Puro Plus panels are double pressed and harden at least 4 weeks under normal atmospheric conditions. Colormat panels are pressed and autoclaved.

BEFORE FINISHING, ORNIMAT, DECOBOARD AND PURO PLUS ARE SUBSEQUENTLY EXTRA DRIED TO A RESIDUAL MOISTURE CONTENT < 5% TO MINIMIZE THE DIMENSIONAL MOVEMENTS.

TECHNICAL CHARACTERISTICS

SVK panels comply with the prescriptions of European standard EN 12467 "Fibre-cement flat panels – Product specification and test methods".

SVK façade panels are resistant to micro-organisms, fungi, microbes, insects etc. So they cannot rot. Ornimat and Decoboard panels are chemical resistant to alkalis and diluted acids due to their coated surface.

PHYSICAL CHARACTERISTICS

		Puro Plus	Decoboard	Ornimat	Colormat
EN 12467	Density – oven dry	≥ 1.700 kg/m ³	≥ 1.700 kg/m ³	≥ 1.700 kg/m ³	1600 ± 50 kg/m ³
	Bending strength	Class 5 (≥ 24 MPa)	Class 5 (≥ 24 MPa)	Class 5 (≥ 24 MPa)	Class 5 (≥ 24 MPa)
	Modulus of Elasticity (wet)	14.000 MPa	14.000 MPa	14.000 MPa	12.000 MPa
	Water impermeabilty	no water drops			
	Moisture movement (30-90 %)	1,2 mm/m	0,7 mm/m	0,5 mm/m	0,8 mm/m
	Moisture movement (30-90 %) //	1,0 mm/m	0,6 mm/m	0,4 mm/m	0,7 mm/m
EN 10545	Thermal movement (-20 +30°C)	0,03 mm/m	0,01 mm/m	0,01 mm/m	
	Thermal movement (-20 +30°C) ⊥				0,58*10 ⁻⁶ /°C
	Thermal movement (-20 +30°C) //				1,71*10 ⁻⁶ /°C

DURABILITY

EN 12467	Class	A
	Resistance to frost	$R_L \geq 0,75$
	Resistance to warm water	$R_L \geq 0,75$
	Resistance to wet-dry	$R_L \geq 0,75$
	Resistance to heat rain	pass

WEIGHT

Puro Plus, Decoboard, Ornimat	$\pm 14,6 \text{ kg/m}^2$
2.535x1.235mm	$\pm 45,7 \text{ kg}$
3.085x1.235mm	$\pm 55,6 \text{ kg}$
Colormat	$\pm 14,4 \text{ kg/m}^2$
2.500x1.220mm	$\pm 43,9 \text{ kg}$
3.050x1.220mm	$\pm 53,6 \text{ kg}$

REACTION TO FIRE

SVK façade panels are non-flammable, they hardly contribute to a fire and there is virtually no smoke development.

Fire reaction class	A2-s1, d0	EN 13501-1
---------------------	-----------	------------

Façade cladding with SVK façade panels is a construction with open joints. Consequently, they do not contribute to the fire resistance, protection against fire penetration or fire spread of the façade construction.

DIMENSIONS AND TOLERANCES

Puro Plus and Decoboard panels are delivered squared or non-squared. Non-squared panels must be squared before installation. Ornimat is always delivered squared, cut to size. Colormat panels are delivered square.

The squared panels meet the requirements of **Tolerance Level I** as per norm EN 12467. For Tolerance Level II (non-squared) see norm EN12467.

Dimensions	Puro Plus, Decoboard		Ornimat	Colormat
	Squared	Non-squared	Cut to size (max. dimension)	Squared
Standard dimensions	3.070 x 1.220 mm	3.085 x 1.235 mm	3070 x 1220 mm	3.050 x 1.220 mm
	2.520 x 1.220 mm	2.535 x 1.235 mm		2.500 x 1.220 mm
Thickness	8 mm	8 mm	8 mm	8 mm

Tolerances	Puro Plus, Decoboard, Ornimat		Colormat
Length	± 1,5 mm		± 2 mm
Width	± 1,5 mm		± 2 mm
Straightness	0,1 %		0,1 %
Squareness	2 mm/m		2 mm/m
Thickness e	± 10 % e		± 10 % e

FINISHING

PURO PLUS

Puro Plus cladding boards are natural grey (due to the cement used). The panels are untreated, they exhibit the honest and natural nuanced appearance of fiber cement and are characterized by their natural aging.

Puro Plus facade boards are lightly sanded, creating a discreet line pattern. As a result, the boards are directional. This direction is indicated by the direction of the production stamp on the back side and by arrows on the protective foil on the front side of the panels.

As the panels are untreated, they are sensitive to weather conditions, and show the typical cementitious surface phenomena such as grey shading, emphasising the natural character of the material. It is highly recommended to order the panels for a continuous surface in one time, to minimize the differences. This is because uniformity of colour cannot be guaranteed.

The presence of small variations (inclusions) in the panel surface are inherent to the production of fibre cement panels and are part of the normal aspect of the wall panel.

Another phenomenon is the possible occurrence of efflorescence. This phenomenon is not necessarily visible immediately and may even become visible after some time (after installation).

Efflorescence in irregular patterns is almost always the result of incorrect storage or handling. Important measures to this matter are to ensure a dry, ventilated storage of the panels (it is not allowed to store the panels outside, not even under a watertight canvas). Always process (drill or saw) the panels dry and immediately remove the drill or sawing dust (cement dust) from the panels immediately. Cement dust left on the surface attaches itself firmly in the pores and causes unwanted visual effects on the panels after their exposure to weather conditions.

The intensity of the efflorescence will diminish with time under influence of the weather conditions. As this is a very slow process it is difficult to predict the total duration before the panels will get a more uniform appearance. This depends on the severity of the efflorescence and the degree of exposure.

The removal of efflorescence is not easy; it is advisable to initially not take any action. However, if result in short term is desired the easiest way is to manually (without electric tools) remove the efflorescence by lightly sanding the panels with an open sponge, for instance „Scotch-Brite 3M 7447“ or equivalent and rinse the chalk dust away. Always sand in dry weather and when the cladding panels are dry. The sanding must happen in linear movement, circular movements could fixate the created dust in the pores which could lead to efflorescence again. Chances remain however that panels treated this way, might show again efflorescence in the future and that the appearance of the panel might slightly change.

DECOBOARD

Decoboard facade panels are given a primer coat and are then finished with a high-quality and durable water based acrylic paint system. This finish has excellent UV resistance and a uniform matt appearance. The back side is provided with a grey-coloured, also water-based coating.

- The panels are not directional, they can be placed in the longitudinal or transverse direction of the panel, according to preference.
- The **Decoboard Classic** range consists of several standard colours. From certain quantities, a large range in almost all RAL and NCS colours is possible.
- The **Decoboard Pure** range has a semi-transparent finish and consists of a number of standard colours. Prior to coating, the panels are sanded, creating a discreet line pattern. As a result, the sheets are directional. This direction is indicated by the direction of the production stamp on the back side and by arrows on the protective foil on the front side of the panels. The colour and structure of the fibre cement remains more or less visible through the finishing layer (depending on the chosen colour). As a result, the tint of the panels is not uniform and can slightly differ between panels.
- The presence of small variations (inclusions) in the panel surface belongs to the normal aspect of the panel.
- The edges of the panel are not coated.

Ornimat facade panels are given a primer coat and are then finished with a high-quality and durable water based two-component polyurethane painting system. This finish has excellent UV resistance and a uniform matt appearance. The back side is provided with a grey-coloured, also water-based coating.

- The panels are not directional, they can be placed in the longitudinal or transverse direction of the panel, according to preference.
- The **Ornimat** range consists of several standard colours. From certain quantities, a large range in almost all RAL and NCS colours is possible.
- **Unique delivery concept:** Ornimat façade panels are delivered tailor-made with the advantage of accurate dimensions, a perfect finish, no panel waste at work or extra sawing work for the installer.
- Ornimat façade panels can be supplied with straight, angled or rounded saw cuts. For mechanical mounting, the holes are also pre-drilled in the factory according to the customer's specifications.
- Ornimat façade panels are first sawn and then coated, so that all panel edges and holes are machine colored.
- No more recesses, openings and special shapes need to be sawn on site. All that remains to be done at the building site is assembly.
- **Clear packaging:** a clear and well-arranged delivery also allows for smooth installation of the panels, the panel characteristics (e.g. East façade, row D) that are communicated with the order are printed on a sticker on the back of the façade panel. The façade panels are distributed across different palettes to the customer's preference, as far as this is practically feasible. In this case, the SVK parts list indicates in which packaging which panels can be found.

Colormat panels are coloured through-and-through and are available in a number of standard and project colours. Colormat panels have a nuanced, natural appearance typical of fibre cement.

The panels are finished with a transparent impregnation making the panels water-repellent. This hydrophobic protective coating will gradually degrade under the influence of changing weather conditions. This reduces its water-repellent effect, however this has no negative influence on the intrinsic properties and quality of the panels. Due to potentially excessive hydrophobic agent, the edges of the Colormat façade panels may appear white. This impacts only the aesthetics aspect of the panels and if desired, can be removed by slightly sanding the edges.

The free lime in the cement of the panels, especially when the protective effect of the hydrophobic layer decreases, may start to react with water and air from the environment to form efflorescences that migrate to the surface. These can then give rise to irregular shade changes/colour variations on the surface of the panel, evolving the aspect of the façade panel. Since efflorescences are white in nature, the impact on colour is going to be greater on dark toned panels than on lighter toned ones. The rate of natural weathering depends on environmental factors such as location, orientation, air pollution and the degree of exposure to UV rays combined with the amount of humidity in the environment.

Mass-coloured products do not have similar colour fastness to coated products. The aspect and colour may therefore change or fade with time.

Colormat Classic facade panels are lightly sanded, creating a discreet line pattern. **Colormat Scripto** facade panels have a unique relief due to additional sanding. **Colormat Touch** has no line structure but a soft crepe appearance. Colormat cladding panels are always directional. This direction is indicated by the direction of the production stamp on the back of the panels. As differences in colour shade are possible, we recommend ordering the panels for a continuous surface surface in one time, to minimise these differences. This is because uniformity of colour cannot be guaranteed.

The presence of small variations (inclusions) in the panel surface are inherent to the production of fiber cement façade panels and are part of the normal aspect of the façade panel. These inclusions can be black, white, red or gray, among others. The size can vary from a few millimeters to a centimeter.

GUARANTEE

SVK provides a guarantee on the façade panels if the materials are stored, handled, installed and cleaned according to the best practice of the trade and in accordance with our current prescriptions and this under normal use and atmospheric conditions.

Tampering of the SVK façade panels and fastening of objects on the façade panels fall beyond the guaranteed domain.

SVK wishes to emphasize that aesthetic phenomena such as efflorescence, inclusions, color nuances, natural aging, etc. are not considered a shortcoming and do not in any way detract from the properties of the façade panels. With regard to mechanical/physical properties and durability, they comply with the requirements of the European standard EN 12467 "Fiber cement flat sheets – Product specifications and test methods".

A material and color guarantee are given for Ornimat and Decoboard classic.

The "colour" guarantee means that the basic color of the Ornimat and Decoboard fiber cement façade panels may not change significantly under the influence of normal weather conditions, except for the normal aging process inherent to each coating, such as the patina of the finishing layer. In the event of exceptional or abnormal weather or environmental factors that affect the color of the façade panels, SVK will not intervene under the warranty. Only SVK will be authorized to judge this.

A coated surface is visually assessed in an outdoor environment, from a distance of 3 m, viewed at an oblique angle of approximately 60° and under normal light (without stray light). The criterion for this assessment is that no imperfections such as excessive roughness, bubbles, craters, matte spots, pits or scratches should be visible. Color deviations are measured according to CieLab. The permitted deviations upon delivery are determined according to data from the Qualicoat directive.

For Decoboard Pure, Puro Plus and Colormat, only a material guarantee is given, no color guarantee.

Decoboard Pure, Puro Plus and Colormat have a nuanced natural aspect, characteristic of fiber cement, with color variations and inclusions. The aspect and color of the panel may change or fade over time due to aging over time.

SVK is entitled to remove or add colours without prior notice.

For further information, please request our warranty certificate.

QUALITY

PURO PLUS, DECOBOARD, ORNIMAT



ETA 14/0284

Z-31.4-192



N° ATT-20/010_V1
<http://www.evaluation.cstb.fr>



Intertek

CCRR-0338
Control No. 5012733

CERTIFIED TO:
ASTM C1186 Type A, Grade IV
ASTM E84
Flame Spread 0 Smoke Developed \leq 5
NFPA 285
Refer to the Intertek Directory of Building Products
(<https://bpdirectory.intertek.com>) for detailed information

COLORMAT



ETA 14/0284

N° ATT-20/011_V1
<http://www.evaluation.cstb.fr>



Intertek

CCRR-0338
Control No. 5011216

CERTIFIED TO:
ASTM C1186 Type A, Grade IV
ASTM E84
Flame Spread 0 Smoke Developed \leq 5
NFPA 285
Refer to the Intertek Directory of Building Products
(<https://bpdirectory.intertek.com>) for detailed information

TRANSPORTATION, STORAGE AND HANDLING

Unless a panel type is specifically mentioned, the following guidelines apply to all SVK façade panels covered in these technical data.

PACKAGING AND STORAGE

SVK façade panels are supplied on pallets, wrapped in foil. This foil does not provide sufficient protection from weather conditions (rain, condensation and bright sunlight). The panels must be protected until they are installed.

Respect closely the next prescriptions:

- SVK façade panels must be transported under a watertight canvas.
- The panels must be stored indoors.
- Limit the storage period on site to the time that is needed to execute the work and keep the packaging closed until the moment the panels are installed. If it is impossible to store the panels inside, carefully cover the panels with a vapor-open, watertight canvas and protect them from precipitation and heavy sunshine. Also prevent the panels from becoming wet or dirty due to condensation, water absorption, dust or any other kind of pollution.
- Facade panels that have become wet in their packaging and show stains, efflorescence or deformation are not covered by the warranty
- To prevent the risk of deformation of the façade panels as much as possible, it is recommended to apply a sufficiently heavy, clean cover panel to the façade panels when storing separately or after opening the pallet. This applies to all SVK façade panels but requires particular attention to Puro Plus as they are provided with a foil on one side and there is no finishing layer on the back. This allows the back to absorb moisture leading to a moisture imbalance resulting in possible deformation.

SVK panels are always stored horizontally, on an even and dry subsoil, clear of the ground.

- Use racks, pallets or supporting laths with a maximal distance of 400mm.
- The panels must be supported sufficiently so that they cannot deform.
- Stack height is maximum 3 pallets. Pallets must not be stacked during transport. Never stack Ornimat pallets on each other.

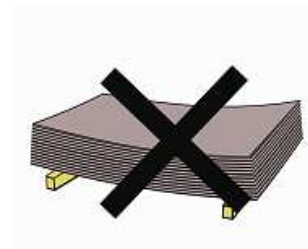
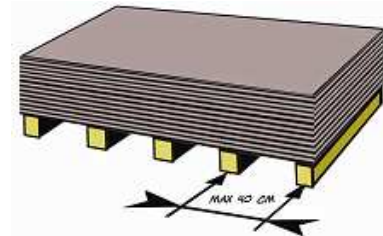

Whilst packing the SVK panels, the finished surface is protected

ORNIMAT AND COLORMAT

The surface of the panels is protected by placing the panels with their front side facing each other. Between the front sides lies a protective foil.

- Always leave this foil between the panels, until the moment they are installed.
- In case the panels are restacked, always replace the protective foil between the panels.
- **Avoid moisture getting between the façade panels and this foil.** Trapped moisture can cause indelible stains or damage to the coating.

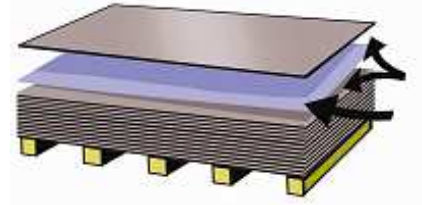

DECOBOARD AND PURO PLUS

- The panel surface is protected by a self-adhesive protective film that is applied to the visible side of the façade panels.
- The production direction is indicated by arrows on this foil.
- The foil protects the panel surface against contamination and damage during transport, storage and processing. Despite this protection, the necessary precautions must be taken:
 - Avoid large temperature fluctuations. Heat can affect the durability of the foil.
 - Limit storage time
 - **Remove the protective film the same day after installation.** If the foil is exposed to sun and rain for a long time, air bubbles can form under the foil. This allows moisture to penetrate between the protective film and the panel surface, which can cause stains on the façade panel.
 - In the case of screws or rivets, loosen a piece of the foil at the mounting location or only fully tighten the screws after removing the foil, to avoid pieces of foil stuck under the screw head.

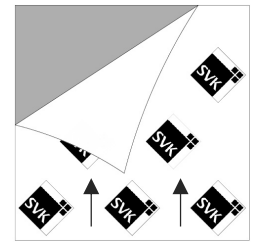

HANDLING

Be careful when transporting or handling the panels, in order not to damage the decorative finishing layer.

- Lift the panels with two people, without dragging them or moving them over the panel below.
- Carry them in a vertical position.
- Avoid staining and wear woolen gloves when lifting the panels.
- Avoid stains of glue, silicone, polyurethane foam as these can leave irremovable stains.
- Do not stick labels, tape of any type of adhesive tape on the decorative surface of the panels. These can leave glue residue on the panel and could affect the decorative surface.
 - Ornimat and Decoboard: the decorative finish (coating) can be damaged
 - Puro Plus: the panel surface can be damaged
 - Colormat: the hydrophobic layer can be damaged when removing the tape. The damage to the hydrophobic layer will be visible and this place will absorb more moisture than the rest of the panel where the hydrophobic layer is still intact.

Whilst transporting and handling SVK façade panels, the legislation related to mobile work equipment for hauling and lifting loads must be always respected.

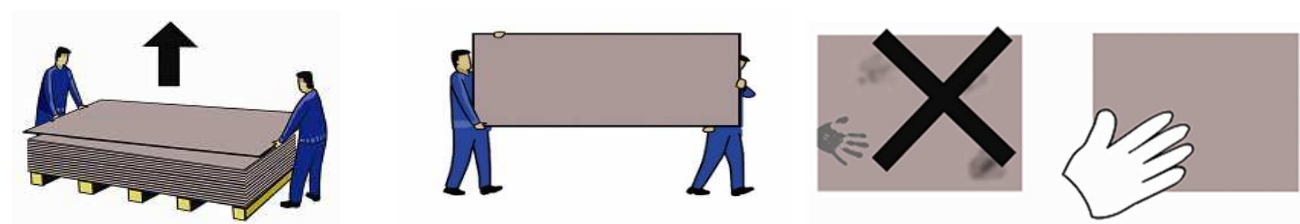

EXECUTION

EDGE TREATMENT

PURO PLUS

As the panel surface is not treated it is not necessary to protect the edges

DECOBOARD

The edges of the panels are not painted.

Decoboard Classic:

After sawing the edges of the panels can be treated if desired for aesthetic reasons by the 'Coloured SVK Protector' edge paint (70ml pack).

Whether or not the edges are treated has no influence on the quality of the Decoboard Classic façade panel.

Decoboard Pure:

All edges and holes must be treated with 'colourless SVK Protector (hydrophobic)' or an equivalent impregnator to avoid discolouration of the edges by water.

COLORMAT

If you wish to treat the edges of the panels after sawing for aesthetic reasons, we recommend doing this with 'colorless SVK Protector (hydrophobicizing agent)' or an equivalent impregnating layer. By treating the edges less moisture will be absorbed along the edges, thus avoiding visible moisture stains at the edges. Whether or not the edges are treated has no influence on the quality of the Colormat façade panel.

ORNIMAT

- Ornimat façade panels are delivered cut to size with mechanically painted edges (and drill holes). The intention is that the panels are fixed on site, without further manipulation needed.
- Finished Ornimat edges do not require additional treatment as they are mechanically painted.
- If additional working of the panels is exceptionally required, be careful to not damage the finished surface. Use Ornimat paint (package 250g) to colour the cut edges of Ornimat panels that are sawn on site.

CUT TO SIZE PANELS

Ornimat panels are always delivered cut to size. Decoboard, Puro Plus and Colormat façade panels are in principle supplied in full panels, but on request SVK can also supply your Decoboard, Puro Plus and Colormat panels cut to size, with or without fixing holes. To avoid errors, we ask that you provide the data clearly and completely. We recommend using the SVK order forms for this. You can download this on our website.

In the case of unusual shapes, it is best to add a clear plan with all dimensions.

GENERAL TIPS FOR WORKING

SVK FAÇADE PANELS ARE BASICALLY TREATED AS A STONY SHEETING MATERIAL

- When sawing SVK façade panels, it is important to know that SVK façade panels consist of hard material.
- Always drill and cut SVK façade panels dry. Only drill or cut in a dry environment.
- Dust is released when processing SVK façade panels. Always use a device with dust extraction and wear the necessary protective equipment, including a dust mask and safety goggles.
- Wear clean gloves to avoid sweat and grease stains on the fibre cement material.
- Always drill and/or cut from the front to the backside. This way, the edges of the front side will remain intact.
- Duly support the panel, provide a stable support and avoid tensions and/or vibrations.
- Work accurately, always saw with a guide rail.

ALWAYS FINISH THE CUTTING EDGES BY MEANS OF SMOOTH ABRASIVE PAPER (NO. 220) OR A SANDING BLOCK

AVOID DRILLING AND CUTTING DUST SEDIMENT ON THE PANEL SURFACE.

- In case there is dust on the panels, it should be removed immediately by means of a soft, dry and pure micro-fibre cloth or a soft brush, before the panels are being processed, exposed to rain or restacked.
- Cement dust remaining on the panel surface causes deterioration of the panel surface or the coating. In case of non-treated panels (Puro Plus), this dust settles in the pores and causes efflorescence once they are installed and exposed to weather conditions.
- Treat Decoboard and Puro Plus panels before the protective foil is removed (sawing, drilling holes, treating the edges).

DRILLING

- For drilling, it is best to use a (metal) drill with a TiN coating (Titanium Nitride) (gold-colored coating). These are suitable for drilling hard materials.
- Do not set the drill to hammer function.
- The best result is obtained when using a drill, specifically designed for fiber cement panels, which has been sharpened at an angle of 70° to 90°. This extends the life of the tool and promotes penetration of the drill into the panel.
- Support the panel at the location of the hole to be drilled.



STRAIGHT CUT WITH BUZZSAW OR CIRCULAR SAW

When sawing large quantities of SVK panels, always work with a professional and sufficiently powerful sawing machine. Choose the right saw blade diameter for the machine used.

**SVK PROVIDES GENERAL ADVICE.
THE OPTIMAL RPM AND FEEDING SPEED
SETTINGS DEPEND ON THE COMBINATION OF THE
INSTALLATION AND THE SAW BLADE USED.
ALWAYS CARRY OUT A NUMBER OF TESTS TO
DETERMINE THE IDEAL SETTINGS**

- Given the high density of the SVK façade panels, a **rotation speed of 2800 to 3600 rpm** (depending on the diameter of the saw blade) is required. The larger the diameter, the higher the speed can be.
- The feeding speed largely depends on the number of façade panels that are sawn simultaneously. When sawing one façade panel with a thickness of 8 mm, you can work at a feeding **speed of approximately 2 to 6 m/min**, provided that the parameters of the machine are set correctly and depending on the total thickness to be sawn.
- Use a diamond coated saw blade. The diamond blade must be suitable for hard materials such as natural stone, ceramics, etc. A continuous diamond blade gives the best cut but is less suitable for large quantities due to less cooling. For large volumes it is recommended to work with a segmented saw blade. Such a saw blade gives a good result and sufficient cooling of the saw blade is possible.
- To obtain the best performance and correct cooling of the saw blade, it is very important to rotate the saw blade away from the cutting area for a few seconds, so that the saw blade can cool effectively in the air.
- When using hand equipment, experience shows that a plunge saw often gives a better result than a circular saw.
- For façade panels with protective foil, the foil does not need to be removed before sawing.
- For detailed advice on blade selection, please refer to the equipment supplier. Solga is rather for professional installations, Diam is also suitable for handheld equipment.



Segmented diamond blade, e.g. Solga



Continuous diamond blade, e.g. Diam TS60

ROUND APERTURES WITH A HOLESAW.

- Make small saw cuts by means of a holesaw with centre drill.
- Use a saw blade with diamond cladding

APERTURES WITH A JIGSAW.

- Cut the desired shape with a jigsaw.
- Use a carbide-tipped saw.

PROTECTION AND MAINTENANCE

PROTECTION

PROTECTION DURING CONSTRUCTION

SVK façade cladding panels are used for decorative finishing. Try to plan the execution at the end of the building phase, to avoid damage and pollution due to subsequent work.

The façade panels are preferably installed from top to bottom, using a support rail. This way, there is no risk of contamination or damage to the underlying panels. In addition, the scaffolding can be dismantled when work progresses to a lower floor.

PROTECTION FROM GRAFFITI

The risk of graffiti is imminent at some locations. For surfaces at risk, it is recommended to preventively provide a permanent protection layer against graffiti and other pollution (markers, ink, etc.). SVK panels are not provided with anti-graffiti layer but are adequate for treatment with protective products against graffiti. These can vary dependent on the panel type. As there are different types of anti-graffiti protection, dependent on the subsurface and wishes of the customer, it is recommended to have this executed by a specialized firm.

MAINTENANCE

GENERAL MAINTENANCE GUIDELINES

To maintain the attractive appearance each façade, independent of the used material, must be maintained on a regular basis. This way, persistent pollution, which diminishes the durability of the finishing coating, can be avoided. The cleaning frequency depends on the environment and the panel type.

In the first place, we recommend restricting pollution as much as possible, especially irregular pollution, by a well-thought-out design. Provide good sealing, overhangs, drip edges, etc.

Façade panels with coating (Ornimat/Decoboard):

Due to their low porosity Ornimat and Decoboard panels are less susceptible to pollution. For standard maintenance we recommend the use of clean tap water. For more persistent pollution a neutral, non-abrasive all-purpose cleaner with sufficient foaming is recommended. Dilute sufficiently following the instruction guidelines. Never use soaps containing linseed oil, nor an ordinary household detergent. First try out the product on a small area.

- Clean with a sponge or a soft piece of cloth. In case of large surfaces, a soft brush can be used for soaping, but see to it that hard parts of the brush do not cause scratches on the panel.
- Avoid hard scrubbing: this causes a "polishing effect", which slightly modifies the panel appearance.
- Do not let the soap solution dry in.
- Amply rinse with water.
- For rinsing afterwards, water can be vaporized over the surface without pressure (e.g. a garden hose, which vaporizes the water over the panel under a broad angle). For this working method, it is necessary that the rear construction is carried out impeccably with regard to water evacuation, ventilation and water tightness.

Façade panels without coating (Puro Plus/Colormat):

For normal maintenance, follow the method described for the façade panels provided with a finishing layer, without the use of all kinds of cleaners or detergents. Use only clean tap water.

EXCEPTIONAL POLLUTION – STAIN REMOVAL

Remove stains as soon as possible. Try to first remove the stains by a regular maintenance. If this does not lead to the desired result, contact our Technical Commercial Department (tcd@svk.be). As there is such a large amount of cleaning products and pollution types, depending on the case, SVK can help you further or refer you to a specialized firm.

For pollution by graffiti, we recommend you contact the firm which provided the anti-graffiti treatment.

SCOPE OF APPLICATION

These guidelines are valid for applications in buildings up to a height of 40 m with normal exposure to wind.

FOR EACH CONSTRUCTION A STUDY OF THE FAÇADE CONSTRUCTION MUST BE MADE BY A RECOGNIZED STUDY AGENCY

The following processing guidelines apply to vertical, ventilated cladding with SVK panels, installed with open horizontal joints. The panels can also be used as a ceiling finish.

The maximum intermediate distance from the supporting structure is determined, considering the own weight and wind loads determined according to Eurocode 1991-1-4 and national building regulations which lists the exact calculation values. Annex I provides non-binding guideline values for these intermediate distances.

The classification of the different geographical areas of the United Kingdom and Ireland, with their corresponding wind speeds, is shown in the following figures:

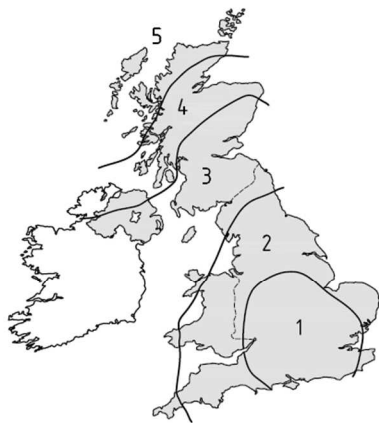

Geographical wind zone	Design wind pressure, $p_{u,r}$ for underlay (N/m ²)
5	1 600
4	1 330
3	1 150
2	975
1	820

NOTE 1 This figure is based on [A1](#) Fig. 1 in BRE Digest 489 [18]. For greater clarity users are advised to refer to the enlarged version in this document. [A1](#)

NOTE 2 Zones 3 and 4 apply to Northern Ireland. [A1](#) Zone 3 applies to the Scilly Isles and Channel Islands. Zone 5 applies to the Shetland Islands. [A1](#)

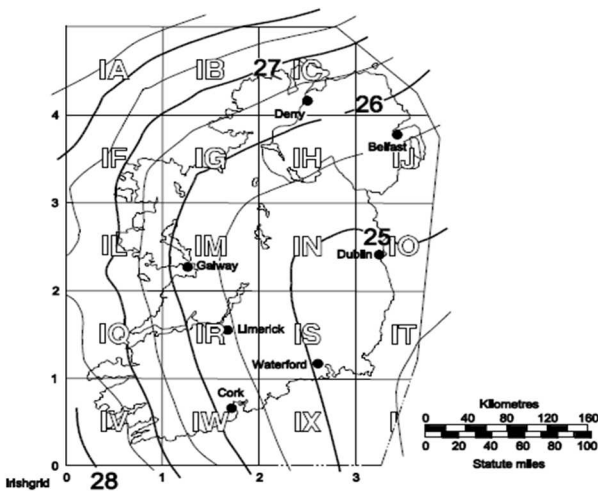

NOTE This map is intended for sites in the Republic of Ireland only. User to reference NA to BS EN 1991-1-4 when designing in Northern Ireland.

Figure NA.1 — Value of fundamental basic wind velocity $v_{b,ref}$ (m/s) before the altitude correction is applied

CONSTRUCTION ASPECTS OF THE VENTILATED FAÇADE

ADVANTAGES OF A VENTILATED FAÇADE

- No risk of internal condensation:
Moisture migrating from the inside of the building into the cavity behind the façade panels can accumulate and lead to condensation when reaching a cold insulation surface. In case of a well-ventilated cavity, this moisture can be easily removed, and excess condensation is avoided.
- Limited heating of the construction due to sunshine:
The surface of a construction quickly warms up due to sunshine. A dark panel can heat up to a temperature of 60° C or more. Thanks to a sufficient cavity ventilation, the basic building structure is not exposed to such high temperatures.

VENTILATION

SVK façade panels are always installed ventilated. It is important that air inlet and outlet is provided at the bottom and top of the façade, but also at the bottom and top of each façade interruption (windows, balconies, etc.), so that smooth air circulation and therefore rapid drying of the cavity space is assured.

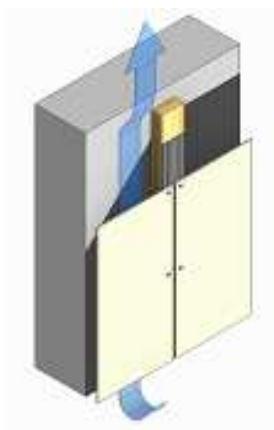

PROPER VENTILATION CONSISTS OF THE COMBINATION OF 3 ELEMENTS

1. AIR INLET AT THE BOTTOM
2. AIR CAVITY BEHIND THE FAÇADE PANELS
3. AIR OUTLET AT THE TOP

IF ONE ELEMENT IS MISSING, VENTILATION IS NOT POSSIBLE

The better ventilation is provided, the better heat and moisture are removed. This way your façade will remain beautiful for longer and it is also beneficial for the indoor climate of the home. We therefore strongly recommend providing more than the minimum (as shown in the table below), especially for projects with high exposure to moisture (north façade in wooded area) or heat (south façade, no shelter).

AIR CAVITY

To achieve proper ventilation, provide a continuous cavity between the back of the panels and the surface of the insulation or the rear structure.

Height of building	Minimum	Recommended
0 – 10 m	20 mm	40 mm
10 m - 20 m	25 mm	40 mm
> 20 m	30 mm	40 mm

For heights > 20 m, interpolation may be necessary to determine the required cavity depth. These values are minimums. Always follow local regulations and increase the cavity width if necessary.

AIR INLET AND AIR OUTLET

The minimum air inlet and air outlet is 100 cm² per running meter. This corresponds to a continuous gap of 10 mm. This is the effective, net space. Section loss due to, for example, a ventilation profile or other interruptions must be considered. A 33% perforated profile must therefore be 3x wider than the recommended dimension.

To prevent pests from entering, ventilation openings can be finished with a perforated ventilation profile.

At the very bottom of the building, at ground level, the vertical distance from the bottom of the panel to the finished level (paving, lawn...) should be at least 50mm. This also applies if the façade starts above a flat roof. The distance is then measured to the roof covering. Good maintenance should ensure that this opening is not blocked by debris such as leaves, dust, moss.

In high-rise buildings it is recommended to compartmentalize uninterrupted façade surfaces vertically (horizontally). A vertical ventilation flow becomes saturated after approximately 10 m and the chimney effect decreases. A profile is installed at the horizontal compartmentalization to interrupt the air flow. The saturated air is exhausted out and fresh air is drawn in again.

INSULATION

The thermal resistance of a façade construction is determined by the thermal insulation of the inner wall and/or by the insulation applied to this inner wall. Large insulation thicknesses are possible when cladding with SVK façade panels.

**THE SVK FAÇADE PANEL AS SUCH DOES NOT
CONTRIBUTE TO THE THERMAL INSULATION OF
THE CONSTRUCTION AND IS NOT TAKEN INTO
ACCOUNT IN THIS CALCULATION**

To obtain optimum insulation, thermal bridges should be kept to a minimum. A support structure on support brackets or adjustable screws is therefore recommended for constructions with high insulation requirements.

Cladding with SVK panels is done with open horizontal joints, so the insulation must be sufficiently resistant to, or protected from, weather influences throughout the life cycle of the cladding/building.

Choose an insulation type that meets the characteristics imposed in annex I of the ETA certificate (ETA 14/0284) and check that the insulation type you choose meets all the requirements for thermal insulation, sound insulation, fire reaction, UV resistance, moisture absorption, etc.

It should be assumed that façade materials (including sub-frame and fixing) are exposed to moisture on a regular basis:

- Rainwater comes down on the panel surface and enters the cavity through the joints.
- In case of heavy wind, water is blown into the cavity and can horizontally penetrate several centimetres into the cavity.
- Internal moisture migrates through the construction into the cavity.
- Air humidity

Both when defining the material for the back construction as when determining the façade apertures (windows, roof edge, ...), this moisture load should be taken into account.

**SVK FAÇADE CLADDING IS NEITHER
WATER- NOR WIND-TIGHT
THE AIR- AND WATER-TIGHTNESS MUST ALWAYS BE
ENSURED BY THE STRUCTURE BEHIND IT
ALWAYS PROVIDE A WATERTIGHT AND VAPOUR-
PERMEABLE SCREEN**

- Place the waterproof, vapour-permeable screen on the cavity side of the insulation.
- Use a vapor permeable foil (maximum μ_d value = 0.05 m) with a high UV resistance.
- Make sure that the screen is elastic and has sufficient tear resistance. Take care of overlaps and connections so that these are also perfectly sealed. Secure the edges of the foil properly, making sure that ventilation is not obstructed.
- Choose a black screen, this gives a uniform black background at the panel joints.

Cladding with SVK façade panels is a self-supporting façade finishing system: the panels transfer their own weight and the wind load via the supporting structure to the load-bearing inner construction. The panels cannot absorb any loads other than these, so do not attach objects directly to SVK façade panels.

- The mechanically painted edges of Ornimat are used to their full.
- Thanks to the open joints the panel edges remain attractive, neither dust nor dirt will accumulate in the joints.
- If needed, the lower horizontal panel joint can be sealed by means of a profile in order to prevent undesired objects from penetrating into the cavity.
- Joints are not to be considered as a ventilation void.

EXECUTION - SUBFRAME

GENERAL

The SVK façade panel is installed on a timber or aluminium subframe.

THE VALUES IN THESE TECHNICAL DATA ARE GUIDELINE VALUES

THE FIXING, DIMENSIONS, SECTIONS AND INTERMEDIATE DISTANCES OF THE ENTIRE FAÇADE SYSTEM MUST BE CALCULATED BY A STUDY BUREAU BASED ON THE MAXIMUM ALLOWABLE DEFLECTION, PULL-OUT VALUES AND TENSIONS TAKE INTO ACCOUNT WIND ZONE, TERRAIN CATEGORY, BUILDING HEIGHT AND PROJECT- SPECIFIC CONDITIONS

- Only use material that has been specially designed for use in a façade cladding system.
- Install the structure with the necessary care: check the straightness of the profiles, consider the manufacturer's guidelines, draw the position of the supporting profiles on the façade in accordance with the plan and pay sufficient attention to the alignment of the subframe.
- Choose a system where the subframe can be easily aligned. The flatness of the sub-frame is the same as the required flatness of the façade cladding.

THE MAXIMUM UNEVENNESS IS $L/1000$

(L= PANEL LENGTH)

- The façade panels cannot be placed properly if the supporting structure is not flat and even.
- Always place the profiles of the substructure vertically, so that the water in the cavity can drain smoothly and ventilation flow is possible.

FIXING THE SUPPORT SUBFRAME TO THE LOAD-BEARING CONSTRUCTION

- The load-bearing construction on which the subframe is installed must have sufficient stability and load-bearing capacity.
- The surface to which the subframe is attached must be sufficiently dry to avoid shrinkage stresses after installation.
- Use fasteners that are suitable for the material of the subframe and the load-bearing construction.
- Use fasteners with sufficient resistance to the tensile and shear forces that occur. This applies both to the attachment of the subframe to the load-bearing construction and to the mutual attachment of the constituent elements of the substructure.
- The distances between the brackets are determined by calculation, but may not exceed 1350 mm. The distance between the mounting and the top and bottom of the profile is maximum 150 mm.

Work with durable wood (own natural durability or treated/preserved – cfr EN 335, EN 460 en EN 350-2). Use wood with strength class C24 (EN338). Only use wood that is clean, dry (moisture < 18%), dust- and grease-free. Use wood with sufficient dimensional stability that also remains flat after alignment. For countries that are not part of the European Union, the national regulations are to be followed.

SUPPORT BRACKETS

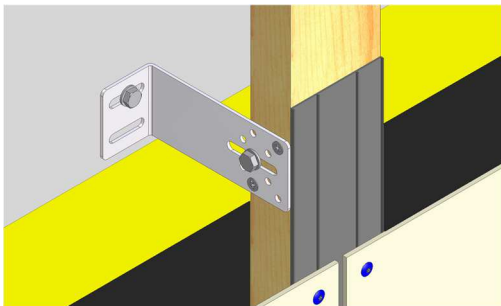

Support brackets should be made of galvanized steel.

RULE OF THUMB FOR THE DISTANCE BETWEEN THE BRACKETS: MAX 100 CM

The brackets are placed alternately to the left and right of the battens. Moreover, they are placed staggered with adjacent timber battens (not all at the same height).

ADJUSTABLE SCREWS

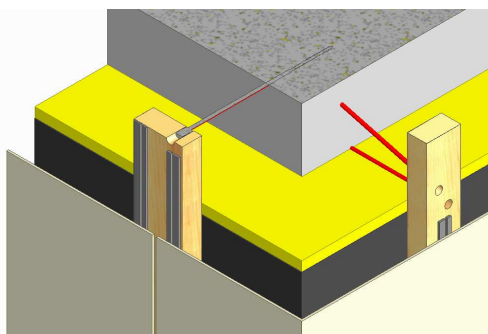

The adjustable screws are made of galvanized steel.

They are fixed to the load-bearing construction with a wall plug, specifically suited to the material of the construction.

Use adjustable screws with a body that can rotate independent of the positioning head. This system allows the adjusting of the wooden substructure, without weakening the anchoring value in the load-bearing construction.

The stability of the wooden substructure is guaranteed when the screws are fixed both horizontal and oblique. The length of the adjustable screws and the amount necessary are determined by a stability study.

Carefully follow the adjustment screw manufacturer's instructions.

VERTICAL SUPPORTING BATTENS

The battens need to be at least planed on one side (fixing side of facade panels). Leave a 5mm joint between the battens.

The dimensions of the battens are determined by calculation. National regulations may impose minimum sections. For screw fixing, the section is also determined by the minimum edge distance and the penetration depth of the screws. The following indicative values can be considered:

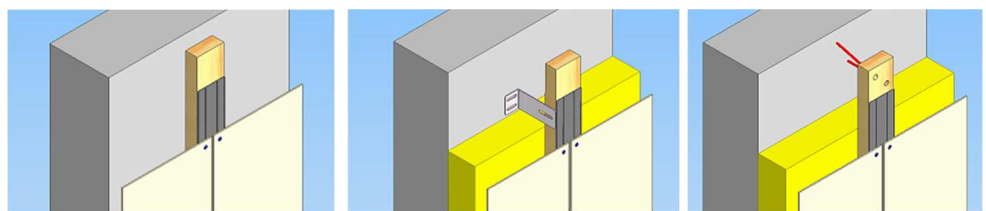

Minimum section battens (T x W) Screws

Fixing of battens:	Direct	Support brackets	Adjustable screws
Vertical joint	40 x 90 mm	50 x 90 mm	40 x 90 mm
Intermediate batten	40 x 40 mm	50 x 40 mm	40 x 70 mm
Angle post	40 x 70 mm	50 x 70 mm	40 x 70 mm

Minimum section battens (T x W) Bonding

Fixing of battens:	Direct	Support brackets	Adjustable screws
Vertical joint	28 x 95 mm	50 x 95 mm	40 x 95 mm
Intermediate batten	28 x 45 mm	50 x 45 mm	40 x 70 mm
Angle post	28 x 70 mm	50 x 70 mm	40 x 70 mm

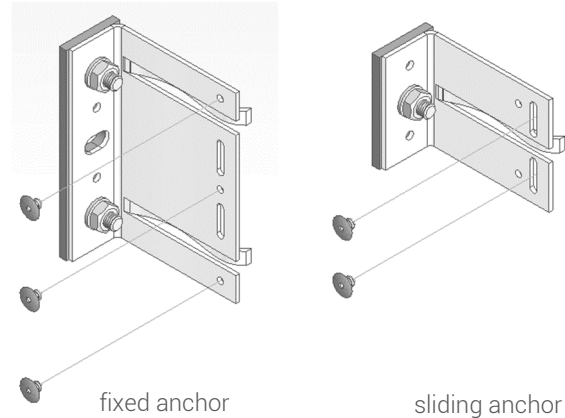
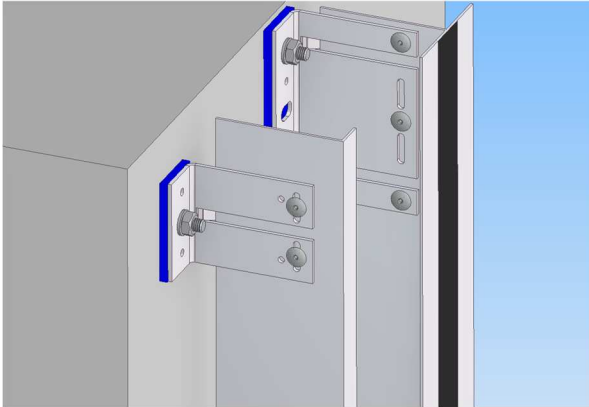

- The sub-frame consists of profiles and brackets.
- Use a system with fixed and gliding anchors (one fixed anchor pro vertical profile) to facilitate the levelling and thermal dilation of the façade. This prevents unwanted tensions in the material. The position and numbers are determined by the manufacturer of the profiles.
- The position of the fixed points and the expansion joints of the vertical rails must always be at the same height within one façade surface.
- Respect the requirements for expansion joints between the profiles. Make sure that the location of these expansion joints corresponds with joints in the building and the joints in the panel cladding. Façade panels may never be attached to two separate vertical profiles.

A FAÇADE PANEL MAY NEVER BRIDGE A JOINT BETWEEN TWO VERTICAL RAILS

- When using many different materials (with different expansion coefficients), there is a greater risk of unwanted tensions in the supporting structure and/or the façade panels.

ALWAYS ENSURE TENSION-FREE FIXING

- The support and fixing distances that apply to the wooden battens do not apply to a metal substructure. The fixing distances should never exceed 600mm.
- The 8mm wide joint leaves the rear structure visible. Use black profiles or stick black tape behind the joint to obtain a uniform dark background.

ALUMINUM

- Aluminum is used because of its weight to strength ratio, its resistance to corrosion, and its easy workability.
- An expansion joint of minimum $\frac{3}{4}$ in. (20 mm) between the rails of the sub-frame should be provided at least every 11,5 ft (3500 mm) (unless the supplier of the sub-frame imposes other distances). These joints should be at the same level of the building joints.
- Use high quality aluminum alloy EN-AW 6060 (T5,T66) and EN-AW 6030, conform norm EN 573-3 and EN 755-2. These alloys are used in extrusion profiles. Pleated profiles are always made from softer alloys and are therefore generally less strong and therefore less suitable for facade applications.

THE MINIMUM THICKNESS OF THE PROFILES IS 2 MM

- As standard, T-profiles with a width of 120 mm (behind vertical joints) and L-profiles with a width of 40 mm (intermediate profile in the middle of a façade panel) are used.
- Profiles are available in various lengths. Some may even match the height of the panels or multiple panels. It is best to take this into account during design.

STEEL

- The steel substructure consists of vertically placed profiles that are attached to the load-bearing structure with brackets of the same material.
- The profiles and brackets must be made of hot-dip galvanized steel, minimum S235 GD and Z275.

THE MINIMUM THICKNESS OF THE STEEL PROFILES IS 1,8 MM

- For a steel supporting structure, provide an expansion joint of 20 mm between the vertical profiles at least every 5180 mm (unless the supplier of the supporting structure prescribes other distances). These connections must be at the same level as the expansion joints of the building (shell construction).

CORROSION

The combination of certain metals in the presence of rainwater/humidity can lead to corrosion. Therefore, avoid the combination of aluminum and galvanized steel - opt for stainless steel instead.

In coastal environments, uncoated aluminum or galvanized support profiles should be replaced with an anodized aluminum or stainless-steel support structure.

Blind rivets must be quality A2 under normal conditions and quality A4 in coastal areas or other areas exposed to an aggressive environment. Applicability must be confirmed by the rivet supplier.

Always protect uncoated aluminum when directly exposed to cement surfaces such as fresh concrete walls.

Avoid contact of support brackets with wood preservatives containing copper, mercury or other incompatible compounds.

Do not use finishing profiles made of materials that can leach (zinc/copper/lead/...).

Contamination due to corrosion on the panels is difficult or impossible to remove.

EXECUTION FAÇADE PANELS

GENERAL

FIXING FAÇADE PANELS

Each panel is fixed with fasteners of the same type. Always take into account both the minimum and maximum edge distances, especially with small panels or strokes. An even distribution must be maintained when positioning the mounting points. Consider the maximum mounting distance imposed by the stability study. Do not add extra unnecessary mounting points, these will only increase the tension in the façade panel. The number of attachment points may not exceed the number determined in the stability study. Avoid fastening points close to inside corners of the facade panel. More stress often occurs at this position, a fixation at this location will cause a greater risk of cracking.



DILATION

SVK facade panels are less sensitive to thermal-hygrid effects than many other panel materials, but the panels cannot be placed against each other to allow the dilatation of the facade panels and to compensate for any tolerances. The fixing system must not impede the dilatation of the facade panels, otherwise too great tensions will arise in the panel. Therefore, always use fixing systems that meet the criteria below.

TO REALIZE A TENSION-FREE FIXATION, A JOINT WIDTH OF 8 MM IS PROVIDED BETWEEN THE FACADE PANELS AND THE FIXATIONS ARE PLACED PERFECTLY PERPENDICULAR TO THE PANEL SURFACE, IN THE CENTER OF THE DRILL HOLE

PROTECTION SUBFRAME

Protect the wooden battens against moisture by applying a UV-resistant EPDM joint tape behind the vertical panel joints that completely covers the batten. This drains the water that penetrates the vertical joints between the façade panels. Also place an EPDM joint tape on the intermediate battens, so that the panels can be placed nice and flat. EPDM joint tape cannot be used when bonding. In this case, choose a dark-colored pre-treatment/wood protection for the (vertical) battens. An EPDM joint tape is unnecessary for metal profiles. To obtain a uniform dark background, a black strip of adhesive tape can be applied to the profiles behind the panel joint, or black profiles can be used.

PROTECTION AND VIEW FAÇADE PANELS

SVK façade panels are high-quality finishing panels. Process them with the necessary care, so that the SVK façade panels are shown to their full potential.

When choosing the panel bond, take the regulations for support and mounting distances into account. If you choose a panel design where the vertical joints are not in line with each other, the façade surface can become unevenly contaminated at the height of the joints.

When installing, keep in mind that some façade panels are directional due to their finish.

FOAM TAPE

The use of foam tape on a metal support structure ensures that three-dimensional dilation is possible in case of metal substructure. The foam tape must be applied to each rail of the subframe and over the entire length of the panel.

Use foam tape with a thickness of at least 5 mm and a width of approximately 10 mm. The foam tape preferably has a density of approximately 60 kg/m³ and a hardness of 50-60 Shore A.

IMPACT

Depending on the nature and strength of the forces that must be absorbed, it may be necessary to take extra precautions for façade panels exposed to impact loads (hard or soft objects). More information about the resistance to impact loads and the measures to be taken can be found in Annex.

FINISHING PROFILES

In certain cases, it may be (aesthetically) appropriate to use an aluminum finishing profile.

- To prevent vermin from entering the cavity, we recommend installing **ventilation profiles** at the inlet and outlet of the air cavity and all other openings wider than 10 mm.
- An exterior corner can be finished extra tightly using an **exterior corner profile**.
- When connected to another façade element or when the sawn edges of the façade panels are visible, it can be finished with a **U-profile**.

Especially when using metal finishing profiles, it is important that these profiles can expand and contract independently of the façade panels. Provide a small expansion joint between connecting profiles and ensure that the joints between these profiles coincide with the joints between the panels.

SAW CUTS – CONNECTIONS

To hang small elements such as a doorbell, light fixtures, etc., a recess must be made in the façade panels so that the element can be attached to the rear structure. Make the opening slightly larger. A minimum clearance of 8 mm is required. The same edge distances must be maintained for openings as for the mounting points.

NEVER ATTACH ELEMENTS DIRECTLY AT THE FAÇADE PANELS

In the case of openings or recesses where the SVK façade panel connects to another structure or another material is fed through the SVK façade panels, the thermal-hygric effect of both materials must remain possible: over-dimension the recess and, if necessary, finish with a permanent elastic, neutral kit. Be careful not to close any ventilation openings.



KIT

Panel joints are never closed with sealant. Flexible connections to the shell, windows, etc. can be finished with a sealant that remains elastic. Only use neutral sealant to avoid staining.

EXCEPTIONAL EXPOSURE OF PANELS

When the surface of the façade panels is exposed to exceptionally heavy chemical or mechanical loads, the finishing layer (Ornimat, Decoboard, Colormat), respectively the panel surface (Puro Plus) ages faster.

INTERMEDIATE DISTANCES FIXINGS

In the annex to these technical data, you will find guide values for the support and fixing distances to be observed and an explanation of the calculation method. These data are general, non-binding guidelines.

THE MAXIMUM DISTANCE BETWEEN THE FIXINGS

IS 60 CM

The distance between the fixings (screws, rivets, etc.) is determined by calculation, considering project-specific circumstances, panel dimensions, number of supports, installation system used, shape of the building, height of the building, wind zone, ...

The wind load is determined based on the Eurocode 1991-1-4 and national annex, which state the exact design values.

The calculated values apply as maximums. They are converted into practical values, depending on the panel dimensions and the desired appearance.

EDGE DISTANCE OF THE FIXINGS

DISTANCE OF THE FIXING POINT TO THE EDGE OF THE PANEL

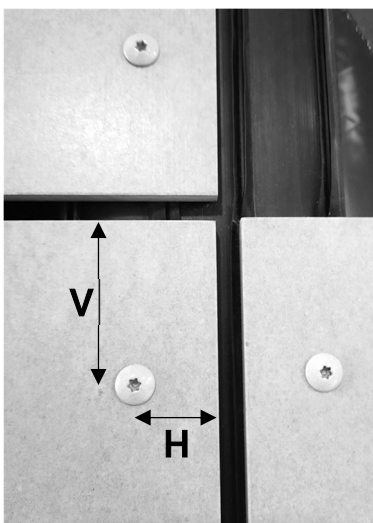

THE DISTANCE FROM THE FIXINGS TO THE PANEL EDGE MUST NOT BE TOO SMALL TO AVOID EDGE BREAKAGE

IT MUST ALSO NOT EXCEED THE MAXIMUM VALUE TO ENSURE FLATNESS

Stresses in the material must be avoided as much as possible. However, at high temperatures or humidity it can happen that the profiles of the subframe (especially with a metal subframe) expand in such a way that the available margin around the sliding point is reached and a (slight) tension is created in the material. After all, the profiles of the subframe expand more than the façade panels.

The attachment of the façade panels consists of one or two fixed points and sliding points. The fixed points must be centrally located because the expansion of the profiles builds up from the center/fixed point to the edges of the façade panel. The risk of reaching the available margin around the sliding point is therefore greatest at the edge fixing points. If these fixing points are placed too close to the edges, there is not enough material left to withstand the pressure and there is a greater risk of the material breaking out.

The minimum edge distances must therefore always be applied correctly.

On the other hand, there is also a maximum edge distance that must be respected. Too large an edge distance results in a larger 'free hanging' part and can cause deformation of the edges of the façade panel.

The minimum and maximum values are:

Edge distance of the screws	Ornimat – Decoboard – Puro Plus		Colormat	
	Minimum	Maximum	Minimum	Maximum
(V) Vertical distance	25 mm	100 mm	70 mm	100 mm
(H) Horizontal distance	25 mm	100 mm	25 mm	100 mm
Edge distance of blind rivets				
(V) Vertical distance	70 mm	100 mm	70 mm	100 mm
(H) Horizontal distance	30 mm	100 mm	30 mm	100 mm
Edge distance of invisible fixing				
(V) Vertical distance	50 mm	100 mm	50 mm	100 mm
(H) Horizontal distance	50 mm	100 mm	50 mm	100 mm
Edge distance bonding	The edge distances that apply are given by the glue producer. The edge distance may never be more than 50 mm.			

DISTANCE OF THE FIXING POINT TO THE EDGE OF THE VERTICAL PROFILE OF THE SUBSTRUCTURE

	Wooden substructure		Metallic substructure	
	Min	Max	Min	Max
Distance to the edge of the profile	20 mm	65 mm	15 mm	65 mm

DIAMETER FIXING HOLES

The diameter of the holes for the fixing points in the panels is determined on the basis of the fixing type and back structure.

	Screws on wood		Rivets on metal	
	Fixed point	Sliding point	Fixed point	Sliding point
Ornimat, Decoboard , Puro Plus	-	Ø 6,5 mm	Ø 5 mm	Ø 9,5 mm
Colormat	-	Ø 6,5 mm	Ø 5 mm	Ø 9,5 mm

VISIBLE FIXING - SCREWS ON WOOD (SYSTEM INCLUDED IN ETA)

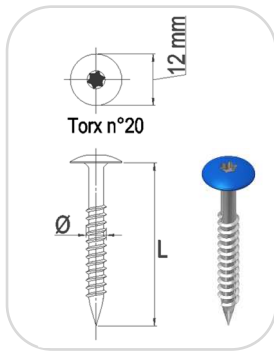

The panels are fixated on the wooden battens with stainless steel screws.

Façade panel screw, timber screw with painted mushroom head Ø 12 mm, Torx impact no. 20.

- Material: Quality A2 under normal circumstances, quality A4 in coastal areas or other areas exposed to an aggressive environment. Applicability to be confirmed by screw supplier.
- Minimum dimension: 4,8 mm (Ø) x 38 mm (L).
- Characteristics conform ETA 14/0284

The screws are fixed using an electric screwdriver equipped with a high-quality bit, adapted to the type of screw head. Use a screwdriver with depth adjustment stop.

THE SCREW HOLES ARE PRE-DRILLED WITH A DIAMETER OF Ø 6.5 MM

The screw holes in the panel are pre-drilled larger (Ø 6.5 mm or 3 mm larger than the screw diameter), to enable the free movement of the panels.

If screws with a diameter larger than 4.8mm are chosen, the screw hole in the panel should also be pre-drilled larger so as not to prevent the movement of the panel.

MAKE SURE THAT THE SCREWS ARE NOT FIXED TOO TIGHT

FIX THE SCREWS PERFECTLY PERPENDICULAR TO THE PANEL SURFACE, NICELY CENTERED IN THE DRILL HOLE, TO ENSURE A TENSION-FREE FIXING

THIS WAY, THE MOVEMENT OF THE PANEL IS NOT PREVENTED

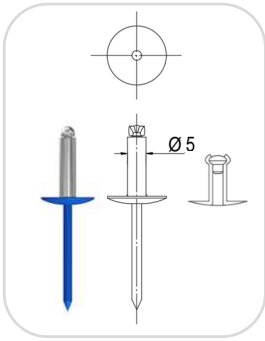

Façade panels on metal battens are fixated with rivets with wide lacquered head \varnothing 16 mm.

- Material: Quality A2 under normal circumstances, quality A4 in coastal areas or other areas exposed to an aggressive environment. Applicability to be confirmed by rivet supplier.
- Minimum dimensions: 4,8 mm (\varnothing) x 16 mm (L).
- Characteristics conform ETA 14/0284

Always use a blind rivet with appropriate clamp reach adjusted to the thickness of the façade sheet and the profiles. With a metal subframe fixed points and sliding points are used to better distribute the expansion of the metal.

THE APERTURES FOR SLIDING POINTS ARE PRE-DRILLED WITH \varnothing 9.5 MM

THE APERTURES FOR THE FIXED POINTS ARE PRE-DRILLED WITH \varnothing 5 MM

If rivets with a diameter larger than 4.8mm are chosen, the screw hole in the panel should also be pre-drilled larger so as not to prevent the movement of the panel.

The profiles are pre-drilled with a diameter of 5 mm. Do this using a centering drill so that the drill holes in the profile are centered in relation to the drill holes in the facade panel in order to allow dilatation. The rivets must be mounted at least 10 mm from the edge of the metal profile. Drillings are executed by skilled personnel.

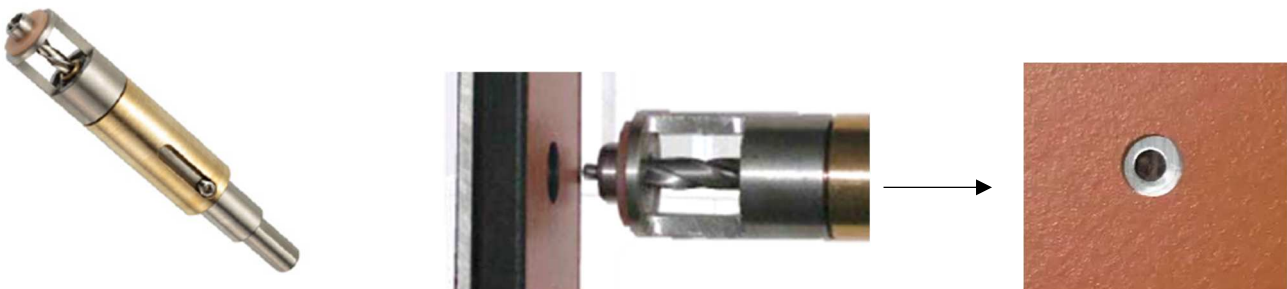

All dust caused by drilling must be removed immediately with a clean dry cloth or soft brush.

PLACE THE RIVETS PERFECTLY PERPENDICULAR TO THE PANEL SURFACE AND NICELY CENTERED IN THE DRILL HOLE SO THAT THE MOVEMENT OF THE PANEL IS NOT PREVENTED

Use a rivet machine with a nose piece to protect the panel. Do not press on the façade panel with the machine.



The panels are installed on a double metal substructure (minimal thickness profiles is 2mm, thickness panel hanger is 3mm) by means of a tension free undercut anchor, socket cap screw and washer.

- **Ornimat, Decoboard, Puro Plus**
Minimal thickness panel: 8 mm
Anchor type: Keil KH (hs 5,5 M6), in stainless steel, quality A4.
- **Colormat**
Minimal thickness panel: 10 mm
Anchor type: Keil KH (hs 7 M6), in stainless steel, quality A4.

- The characteristics of all the components used during assembling must at least correspond to the materials described in the ETA 14/0284. If not, they are outside of the scope of this technical data.
- All components must be of the same manufacturer/supplier.
- The execution is in accordance with the construction drawings made by the design office, by skilled executioners that are trained for this fixing technique.

Design

The stability of the supporting structure, mountings and façade panels must be calculated by an engineering office. At least 4 mountings are provided per panel. The weight of a panel is in principle supported by 2 mountings (1 fixed point and 1 horizontal sliding point in the upper mounting line). The fixed points are provided in the same place as much as possible. The other fixing points are both horizontal and vertical sliding points. The minimum and maximum edge distances of the fasteners and the joint width between the panels (8 mm) must be respected.

Drilling of the undercut hole

The holes are pre-drilled by SVK or a partner recognized by SVK, based on the construction drawings approved by the engineering office or the supplier of the aluminum supporting structure if they provide technical support (regarding the stability of the construction).

- Place the façade panels with the visible side downwards on a flat, clean surface with sufficient support. The façade panels must not bend.
- Mark the positions of the holes to be drilled and check that the correct number of holes have been marked.
- Fiber cement façade panels must always be drilled dry. Do not use water as this may stain the façade panel surface.
- Follow Keil drilling instructions carefully to obtain the required drill dimensions.
- After drilling, immediately remove all drilling dust with a dry soft brush or soft cloth.

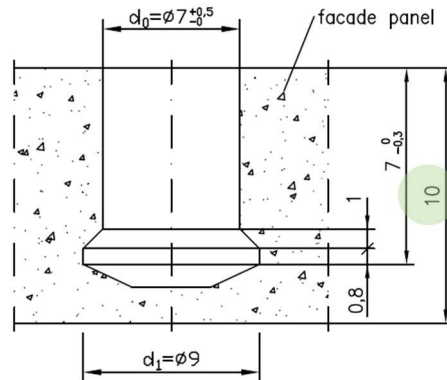
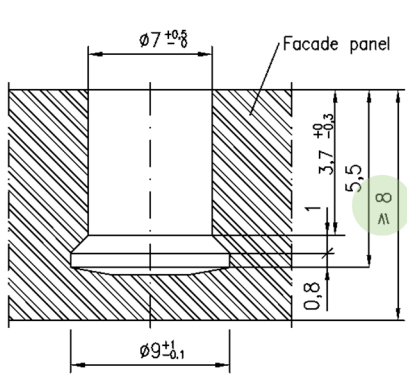

Control of the undercut drill hole

The dimensions of the undercut holes are checked with a control apparatus.

- First test is done by inserting the control gauge base part in the undercut and moving the gauge up to the block. The gauge should be pushed to the base part. If the gauge cannot be pushed to the base part it means that the drilling hole is too deep or that no undercut is provided.
- Second test is done by moving the probe between the panel and the control gauge base part. If the gauge is pushed to the base with the underplayed probe, it means that the drilling hole is not deep enough.
- Both tests must result positive for a correct drilled undercut hole.
- The correctness of the cylindrical hole is checked by a caliper.

At least 1% of all drilled holes have to be controlled.

- For example, if you have 25 panels with 10 holes each (total 250 holes) then at least 3 holes should be controlled.
- During this control, if an incorrect drilled hole is noted then 25% of all drilled holes (equal 63 holes) have to be controlled. No additional incorrect holes should be noted.
- If additional incorrect holes are noted, then all the holes (equal 250 holes) should be tested.
- All incorrect holes are to be discarded and new holes should be drilled. Keep a minimal centre distance of 20mm when drilling the new hole and ensure that the edge distances are respected.

First test

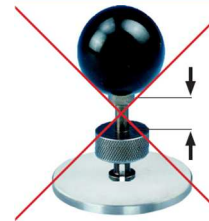
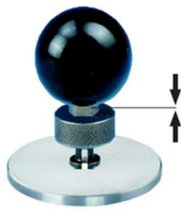

Second test



Installation

After the panels have reached the construction site the assembly of the system can start.

- Ensure the holes are clean and free from any dust or debris.
- Insert the Keil Anchor in the hole and position the panel hanger on the panel.
- Attach the panel hook to the panel using the hexagon head screw that is attached to the Keil anchor. Do not tighten the screw too hard, as this could damage the Keil anchor and reduce the pull-out force of the attachment. The optimal tightening torque of the hexagon head screw is between 2,5 Nm and 4,0 Nm.
- With this attachment, the collar of the Keil anchor is pressed into the milled edge. This way a tension free connection between façade panel and subframe is achieved.

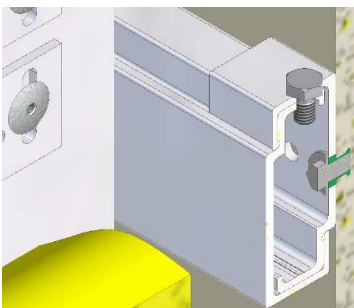
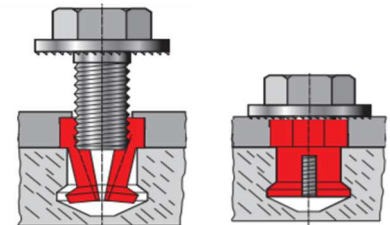

Because of the nature of the invisible mechanical fixing, it is required to install the panels from bottom to top, it is not practical for an installer to adjust and fixate the panel hangers unless there is sufficient free space above the panel. The panels are supported individually and they do not rest on each other (8mm joint around each panel), so the edges are not damaged.

The panels are mounted on the horizontal rails by means of the panel hangers. Each panel is provided on the top with 2 panel hangers with adjustable height, the other panel hangers cannot adjust the height. The adjustable screws on the 2 top panel hangers allow for the levelling of the panels. The horizontal sliding of the panels is restricted by firmly fixating one of the panel hangers on the horizontal rail with a screw. The location of this fixed point needs to be the same for all the panels.

Provide an expansion joint in the vertical battens and the horizontal profile at least every 3500 mm (unless the supplier of the sub-frame imposes other distances) to avoid undesired joint distances between the panels due to expansion of the aluminium profiles.

To narrow the risk of damage a work sequence must be established. SVK façade panels are finished products and are usually installed as the last component. If additional work needs to be done after the installation of the panels, precautions need to be taken to avoid pollution or damaging of the panels.

The installer controls the aluminum subframe, the flatness and the fixing points. In case of irregularities, the contractor/architect has to be informed immediately.

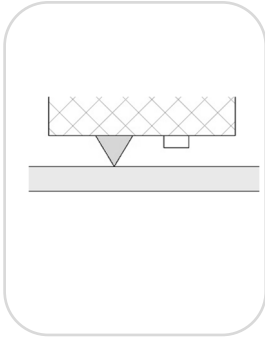

The panels are fixed on timber or aluminum subframes with a permanent elastic bonding system. Bonding system consisting of:

- Cleaning product, pre-treatment and primer for sheet and subsurface, depending on necessity.
- A double-sided adhesive tape, which is meant to provide initial contact retention of the panels and which determines the adhesive thickness.
- An elastic adhesive, creating a flexible and durable connection between the panels and the framework

USE A BONDING SYSTEM SPECIFICALLY DEVELOPED FOR THE INSTALLATION OF SVK CLADDING PANELS

The system must be able to safely and sustainably absorb the weight of the panels, their thermal-hygric effect and all external loads.

SVK façade panels may only be bond with an adhesive system that is compatible with both the supporting structure and the façade panel. **The suitability of the adhesive system must be sufficiently proven** (inspection certificate from an independent institution or equivalent). The adhesive manufacturer has extensive processing instructions, follow these carefully.

The framework must be properly pretreated (cleaning, priming, etc.).

Place the double-sided tape on the side of the vertical joint, so that the glue is not pushed out of this joint when pressed.

Apply a continuous adhesive bead along the entire length of the panel. Provide a sufficiently thick adhesive bead so that the entire length of the adhesive bead makes contact with the substructure when the façade panel is pressed on.

The use of spacers/blocks is not recommended to avoid stains and discoloration on the façade panel. If necessary, use clean spacers/blocks, preferably made of hard plastic, and keep the usage time as short as possible. Never use wooden or metal spacers/blocks, as these can cause stains from tannic acid or rust.

When using spacers, also ensure that the adhesive bead is not compressed too hard and that the minimum thickness of the adhesive bead is respected.

EXECUTION CEILING

GENERAL

A ceiling cladding is a self-supporting ceiling finishing system: the panels transmit their own weight and the wind load through the sub-frame to the load-bearing floor or roof construction. The panels are not able to support any other load, consequently, fixing objects on the SVK cladding panels is not allowed.

The guidelines mentioned hereafter are valid for ventilated ceiling claddings with SVK panels. The panels can be installed horizontally or at an incline. Ceiling cladding can only be installed if the construction above is watertight.

EXCEPT FOR THE GUIDELINES GIVEN HEREFTER, THE GENERAL EXECUTION OF FAÇADE PANELS ARE APPLICABLE

FIXATION

The panels are fixed on a timber or aluminum subframe.

In case of bonding, you can consider fixing the panels with spacers/blocks during the curing period of the glue. To do this, place spacers/blocks (10 cm x 10 cm) in the intersection of 4 panels. These spacers/blocks are screwed into the supporting structure. Do not leave the spacers/blocks on the panels longer than the time required for the panel adhesive to harden. Do not screw these spacers/blocks too tightly so that the glue thickness remains constant and use a material that does not discolor the panel surface. Use clean spacers/blocks, preferably made of hard plastic, and keep the usage time as short as possible. Never use wooden or metal spools, as these can cause stains from tannic acid or rust.

Invisible mechanical attachment with drilled panel anchors may not be used on the ceiling.

SUPPORTING FRAME

The following maximum support distance values must be considered for ceiling cladding:

- Panel carrying battens: the intermediate distance between the panel carrying battens and between the fixings is determined by calculations. The values in the table below can be used as guidelines.
- When using support brackets, a bracket is placed on both sides of the supporting profile

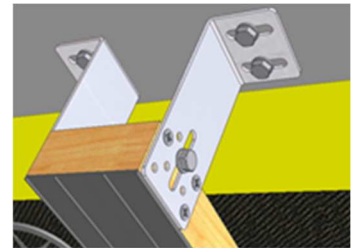

INTERMEDIATE DISTANCES FASTENERS (CEILING)

THE DISTANCE BETWEEN THE FIXING POINTS IS MAXIMUM 45 CM

For panels without intermediate support, a maximum mounting distance of 40 cm is recommended. These values are guideline values, their validity must be verified for each project by a design agency, depending on the specific situation.

EDGE DISTANCE FASTENERS (CEILING)

Distinction between horizontal and vertical edge distances is only important for façades at an incline. For ceiling (horizontal) the smallest values may be selected in all directions.

The minimum and maximum values are:

	Ornimat – Decoboard – Puro Plus		Colormat	
	Minimum	Maximum	Minimum	Maximum
Edge distance screws	25 mm	100 mm	25 mm	100 mm
Edge distance blind rivets	30 mm	100 mm	30 mm	100 mm
Edge distance bonding	The edge distances that apply are given by the glue producer. The edge distance may never be more than 50 mm.			

LIST OF REFERENCE DOCUMENTS

- EN13501: Fire classification of building products and building parts
- EN 12467 "Fibre-cement flat panels – Product specification and test methods"
- ETAG 034: Guideling for European technical approval of kits for external wall claddings. Part 1: Ventilated Cladding Kits comprising Cladding components and associated fixings; Part 2: Cladding Kits comprising Cladding components, associated fixings, subframe and possible insulation layer.
- ETA 14/0284: Ornimat, Decoboard, Puro Plus and Colormat - Wall cladding kit
- ISO 7892: 1988 Vertical building elements
- NBN EN 1991: Eurocode 1: Actions on structures – General actions.
- NBN EN 1993: Eurocode 3: Design of steel structures.
- NBN EN 1995: Eurocode 5: Design of timber structures
- NBN EN 1999: Eurocode 9: Design of aluminium structures.

DRAWI NGS

PRINCIPLE SECTION WOODEN SUBSTRUCTURE

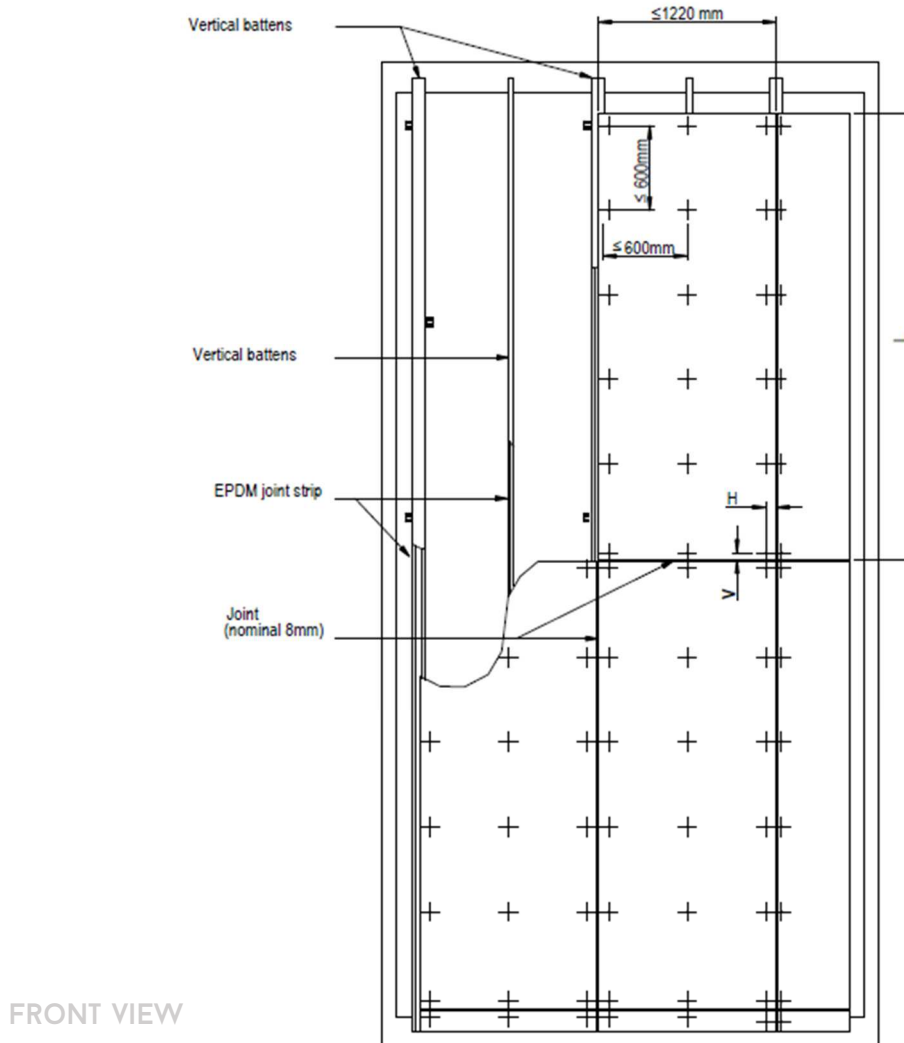

FRONT VIEW

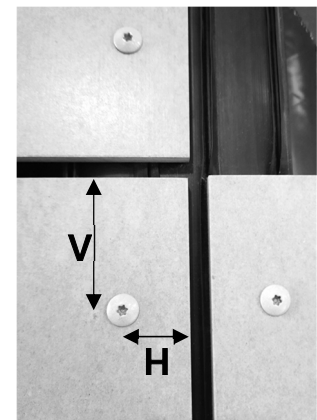

	$H_{\min-\max}$	$V_{\min-\max}$	Screw hole
Ornimat, Decoboard , Puro Plus	25 - 100 mm	25 - 100 mm	Ø 6,5 mm
Colormat	25 - 100 mm	70 - 100 mm	Ø 6,5 mm

VISIBLE FIXING ON SINGLE WOODEN STRUCTURE, MOUNTED ON SUPPORT BRACKETS

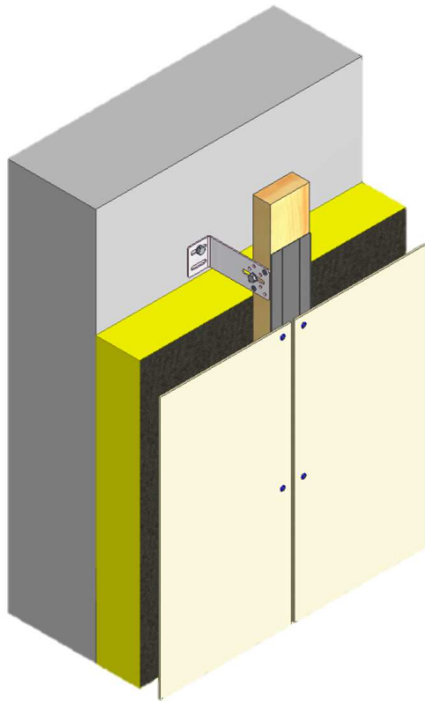

Legend

1.	SVK Façade panel
2.	Insulation
3.	Supporting internal skin
4.	EPDM joint strip
6.	Wooden sub-frame
7.	Screw
8.	Bracket
15.	Ventilation profile

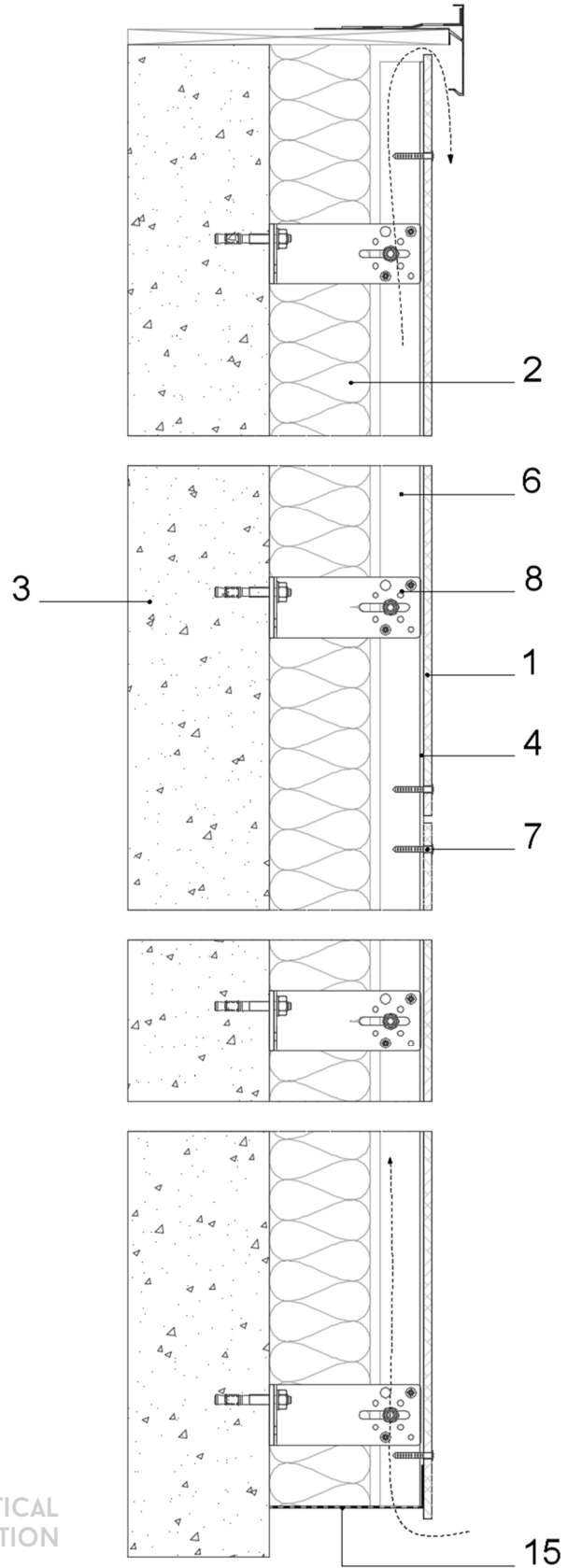

Legend

1.	SVK Façade panel
2.	Insulation
3.	Supporting internal skin
4.	EPDM joint strip
6.	Wooden sub-frame
7.	Screw
18.	Corner profile

HORIZONTAL SECTION

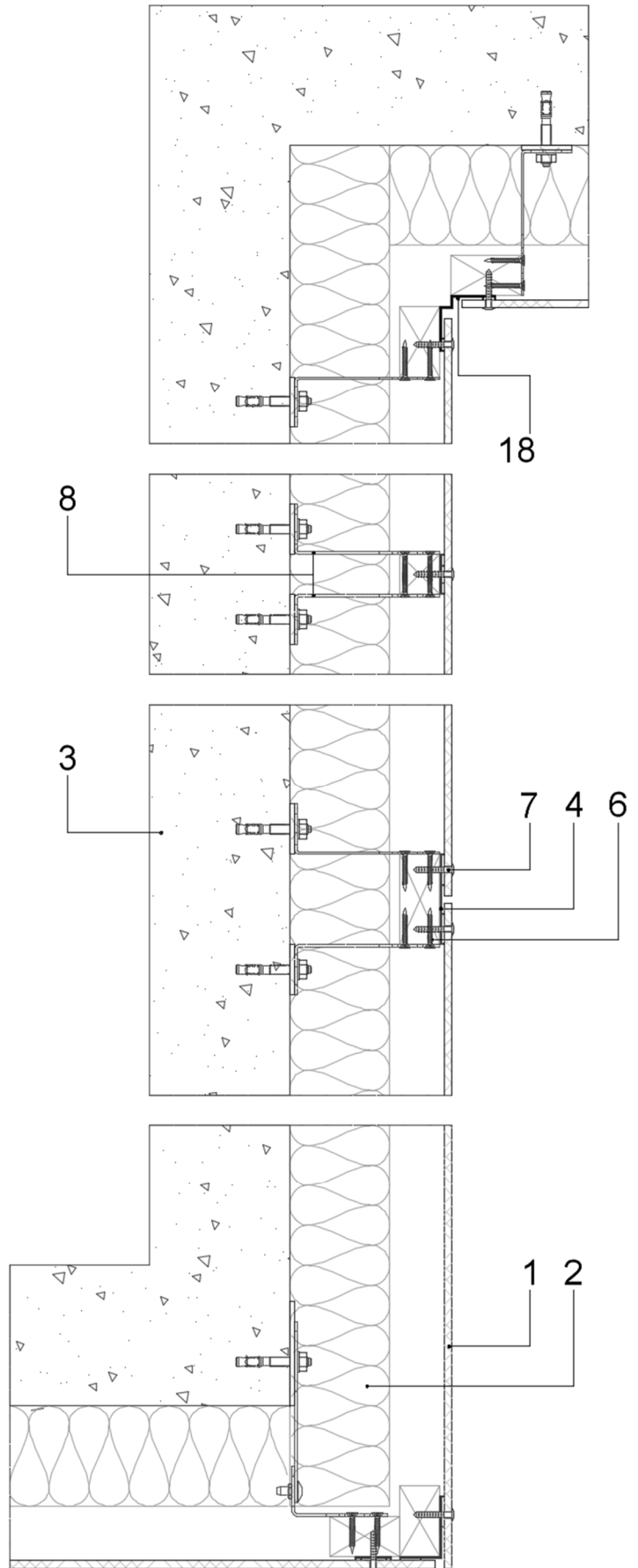

VISIBLE FIXING ON SINGLE WOODEN STRUCTURE – MOUNTED ON ADJUSTABLE SCREWS

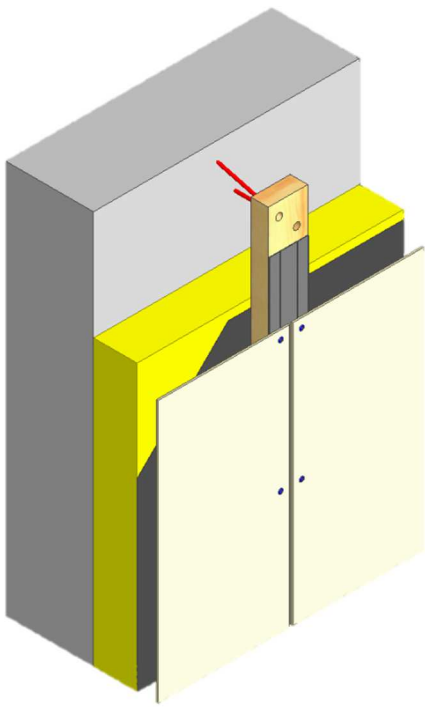

Legend

1.	SVK Façade panel
3.	Insulation
4.	Supporting internal skin
5.	EPDM joint strip
6.	Watertight, breather membrane
7.	Wooden sub-frame
8.	Screw
9.	Bracket
15.	Ventilation profile

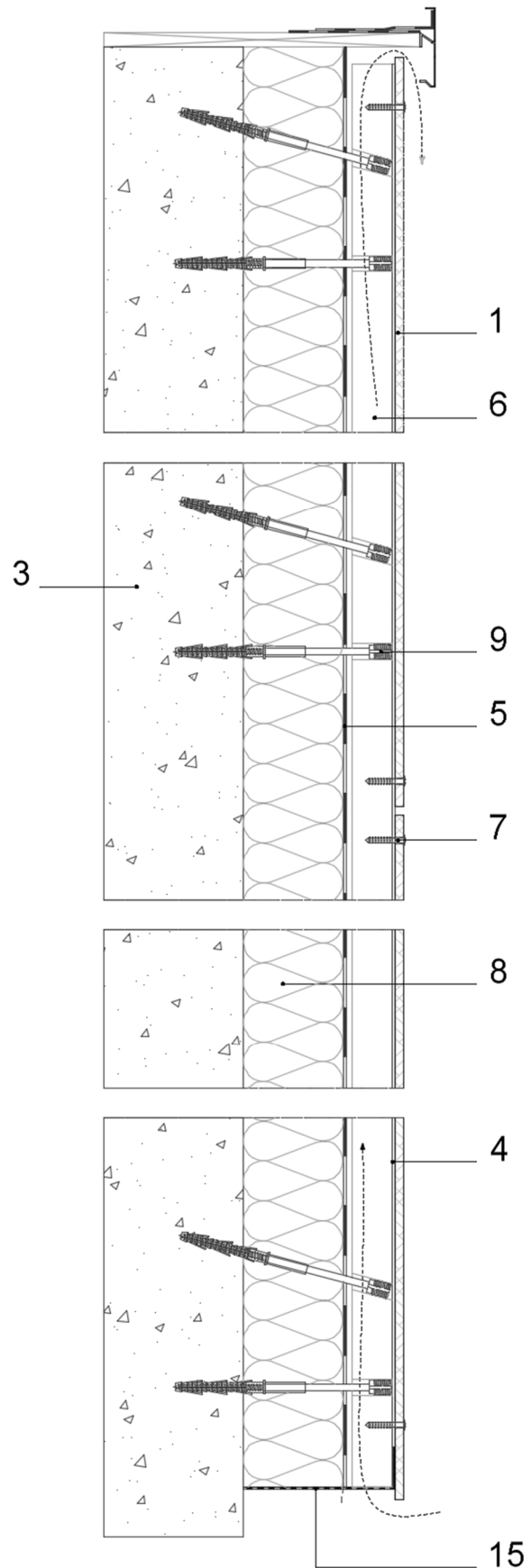

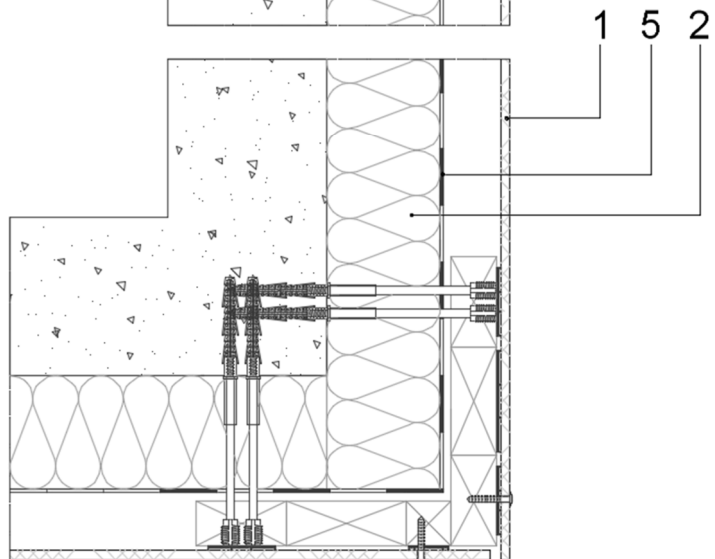
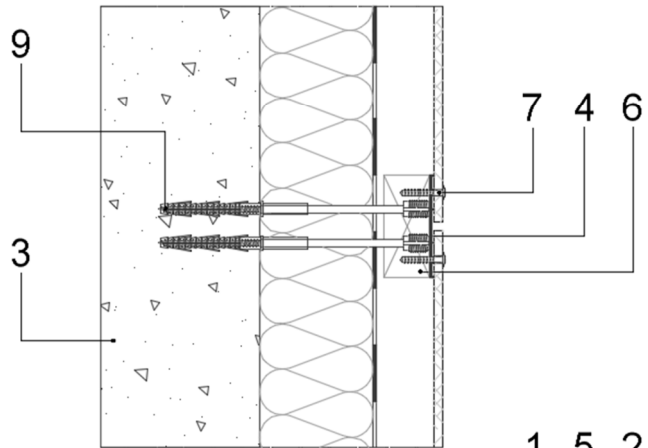
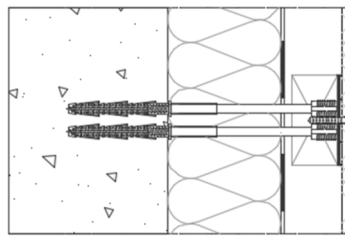
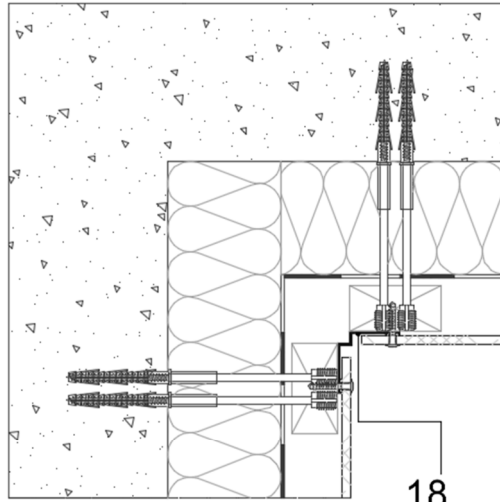

Legend

1.	SVK Façade panel
2.	Insulation
3.	Supporting internal skin
4.	EPDM joint strip
5.	Watertight, breather membrane
6.	Wooden sub-frame
7.	Screw
9.	Bracket
18.	Corner profile

HORIZONTAL SECTION

VISIBLE FIXING ON DOUBLE WOODEN STRUCTURE – DIRECTLY ON LOAD-BEARING STRUCTURE

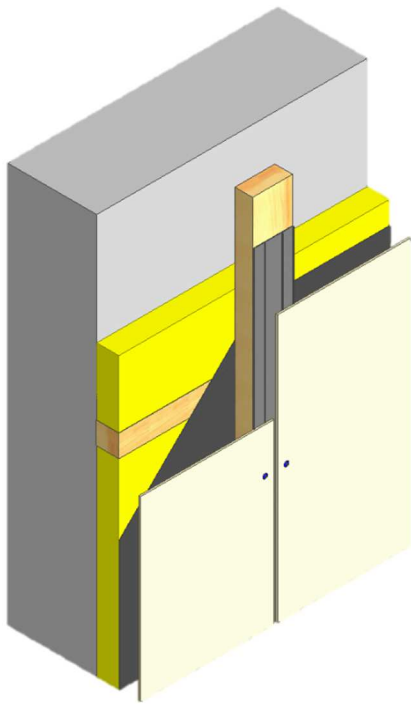

Legend

1.	SVK Façade panel
2.	Insulation
3.	Supporting internal skin
4.	EPDM joint strip
5.	Watertight, breather membrane
6.	Wooden sub-frame
7.	Screw
15.	Ventilation profile

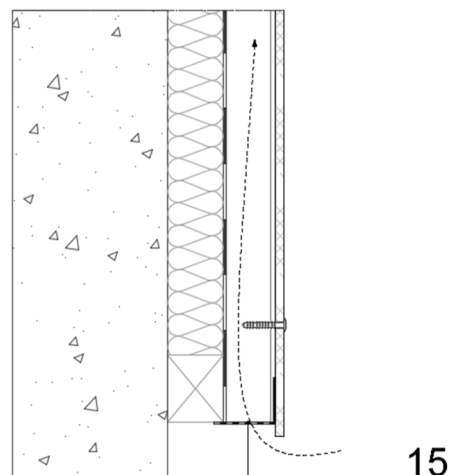
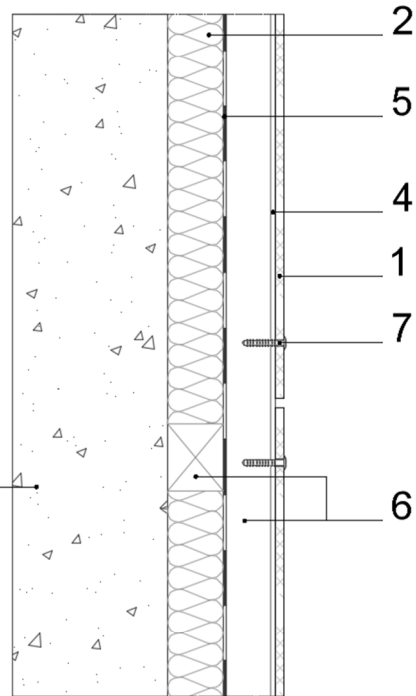
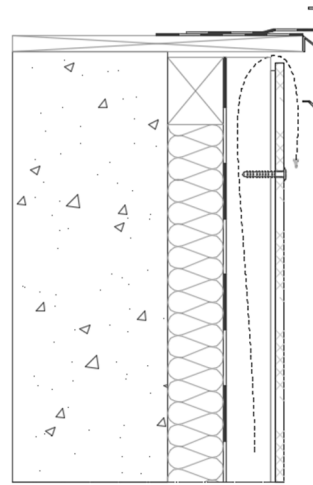

VERTICAL SECTION

Legend

1.	SVK Façade panel
2.	Insulation
3.	Supporting internal skin
4.	EPDM joint strip
5.	Watertight, breather membrane
6.	Wooden sub-frame
7.	Screw
18.	Corner profile

HORIZONTAL SECTION

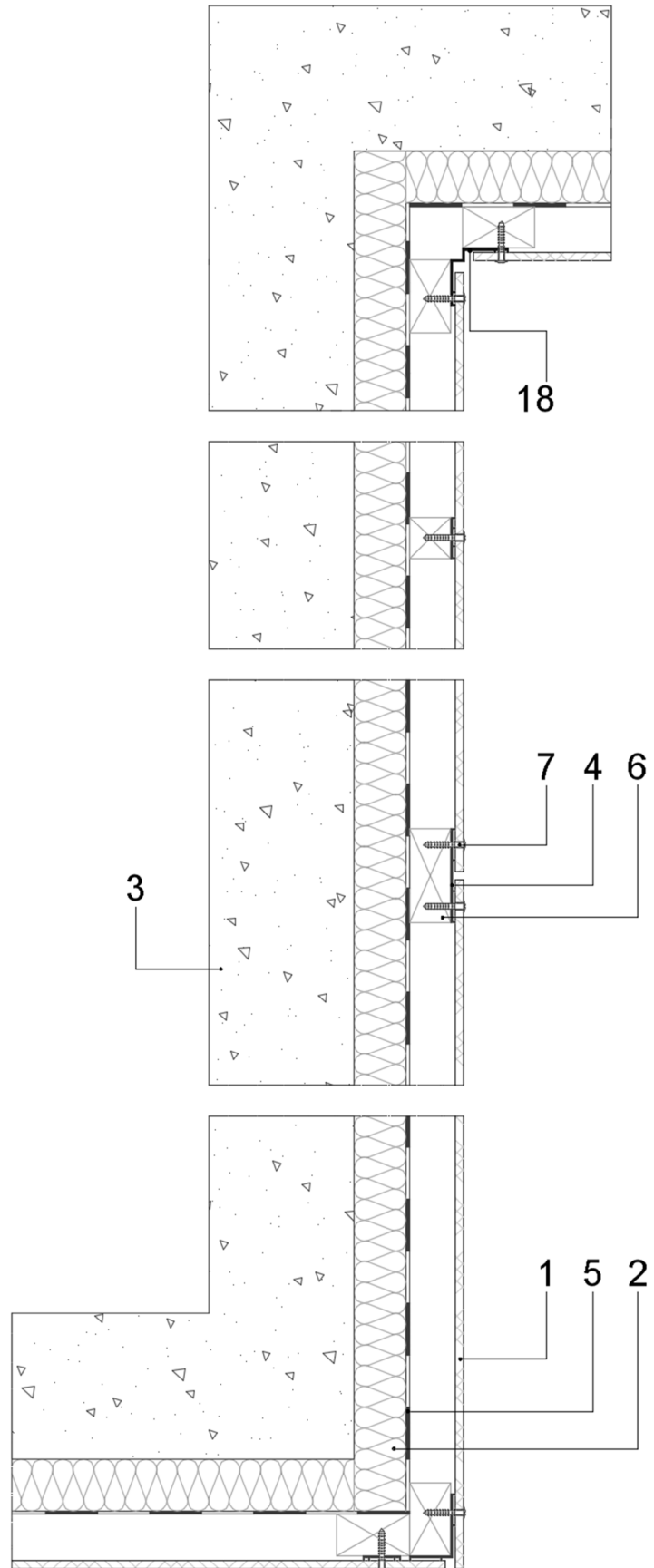

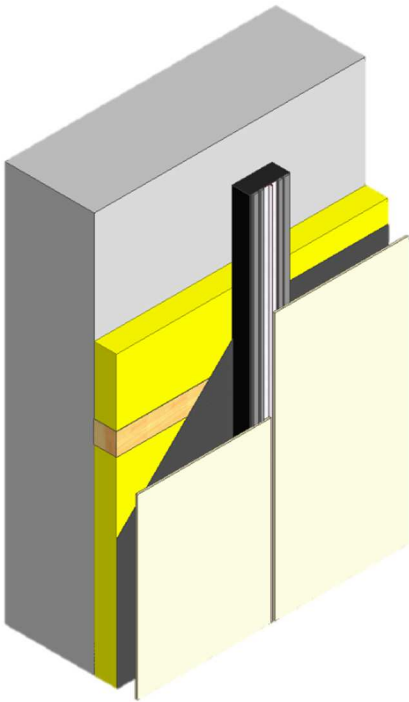

Legend

1.	SVK Façade panel
2.	Insulation
3.	Supporting internal skin
5.	Watertight, breather membrane
6.	Wooden sub-frame
15.	Ventilation profile
16.	Bonding system

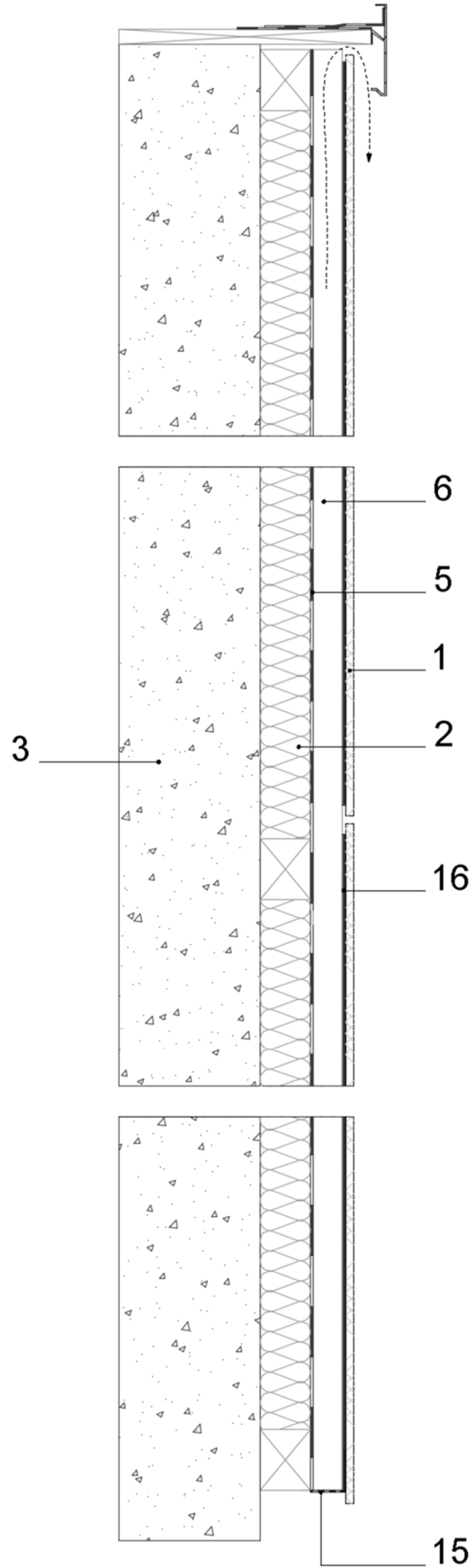

VERTICAL SECTION

Legend

1.	SVK Façade panel
2.	Insulation
3.	Supporting internal skin
5.	Watertight, breather membrane
6.	Wooden sub-frame
16.	Bonding system
18.	Corner profile

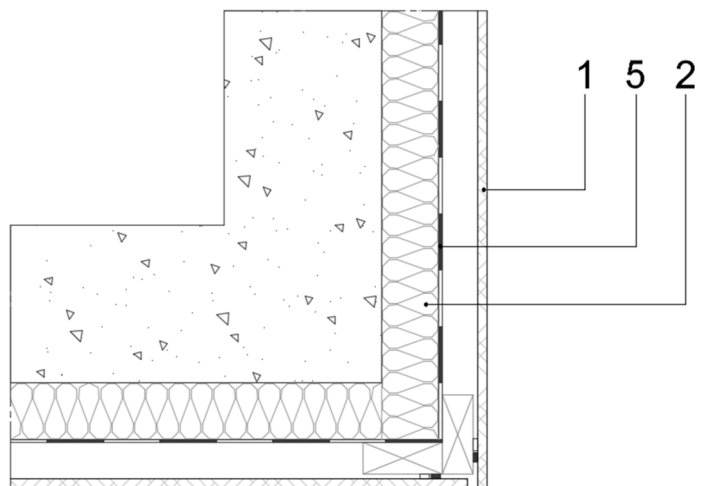
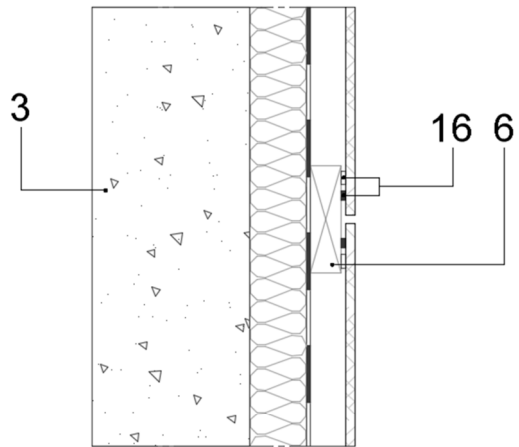
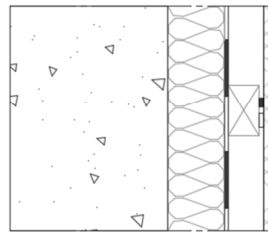
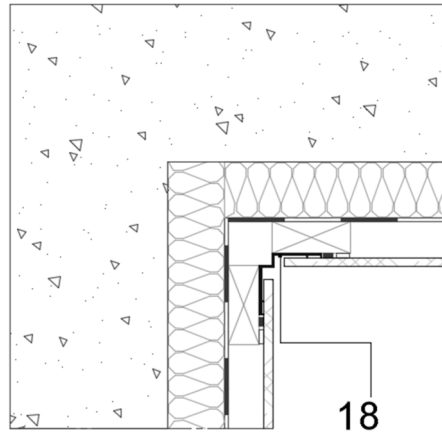

HORIZONTAL
SECTION

CEILING FIXING – SINGLE WOODEN STRUCTURE, MOUNTED ON SUPPORT BRACKETS

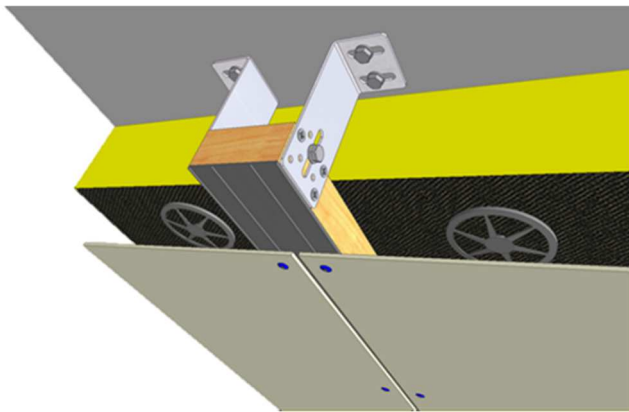
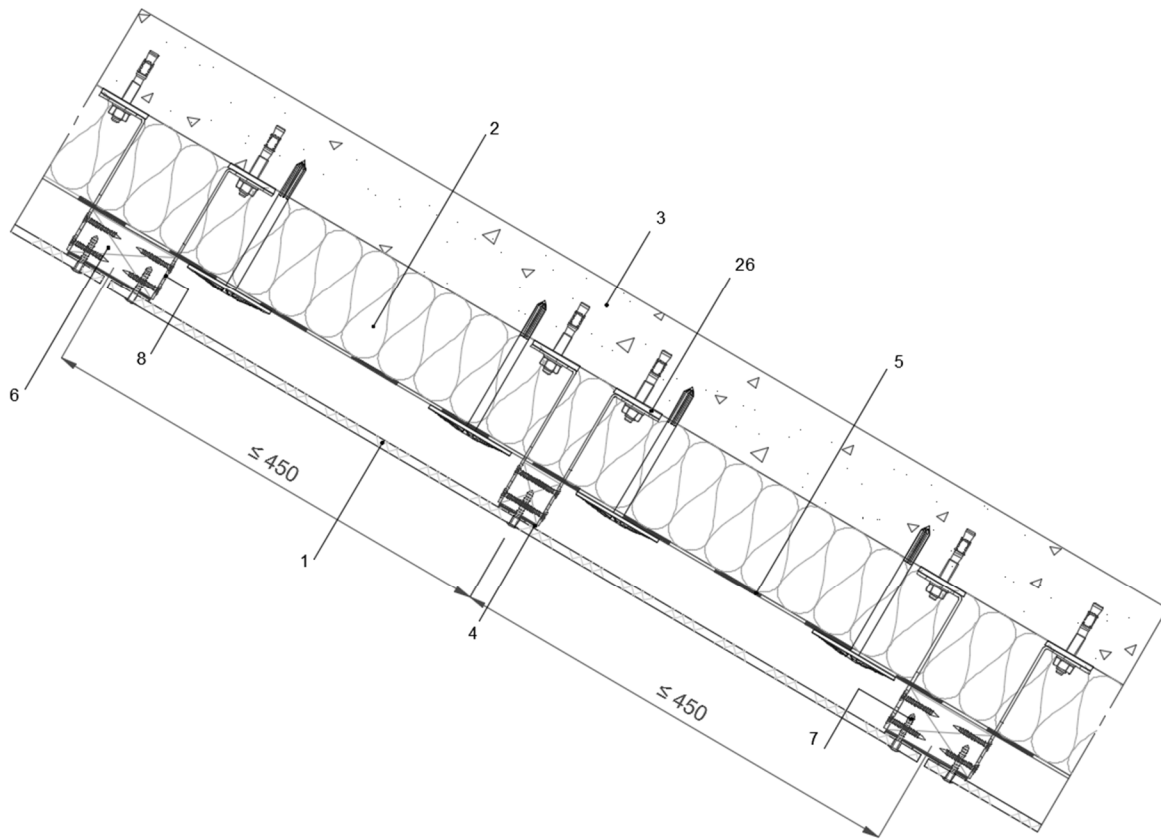

Legend

1.	SVK Façade panel
2.	Insulation
3.	Supporting internal skin
4.	EPDM joint strip
5.	Watertight, breather membrane
6.	Wooden sub-frame
7.	Screw
8.	Bracket
26.	Thermal break

PRINCIPLE SECTION

METAL SUBSTRUCTURE

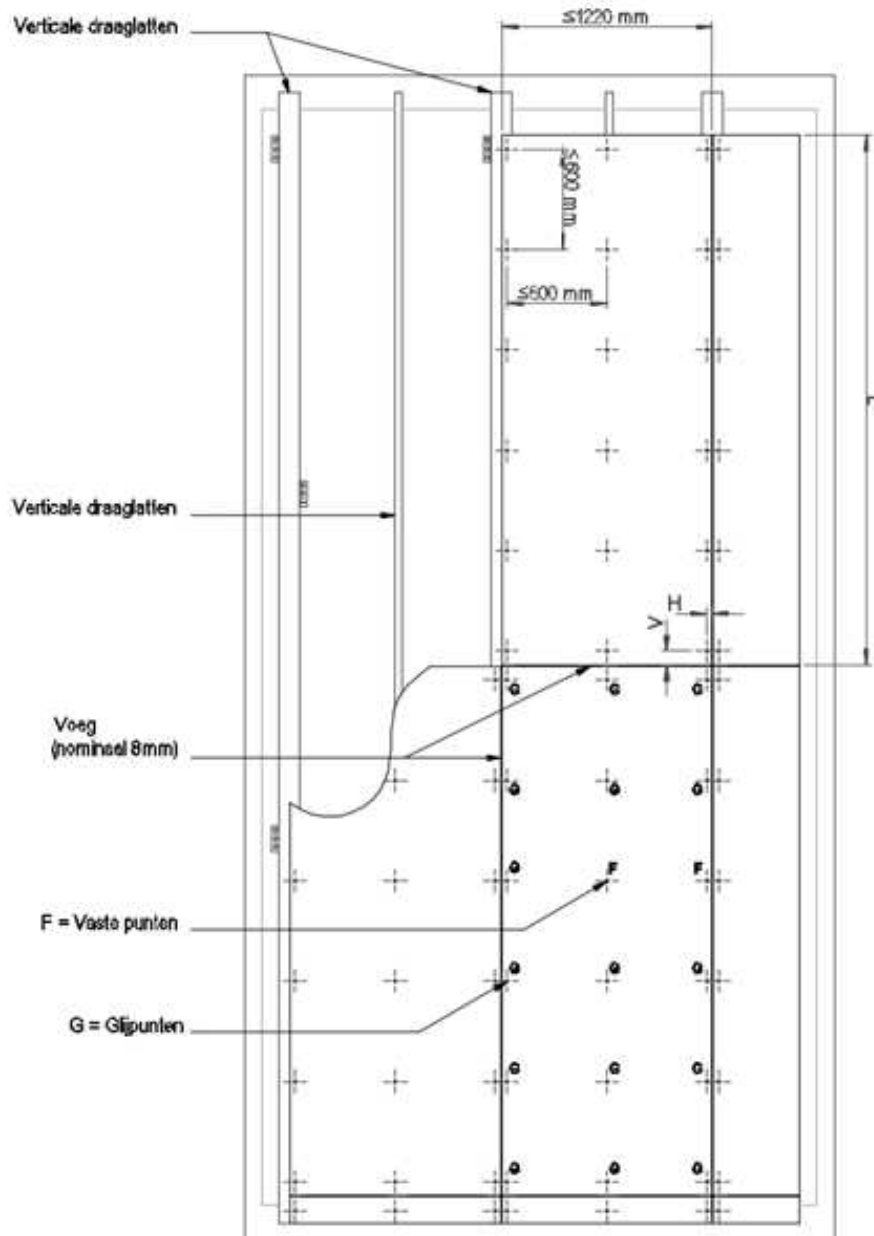
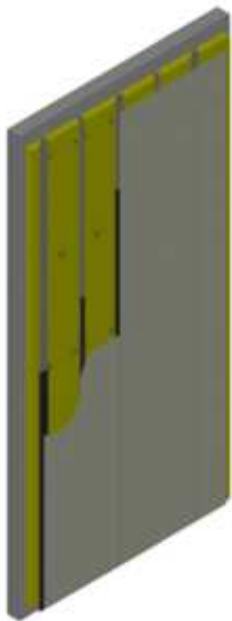

FRONT VIEW

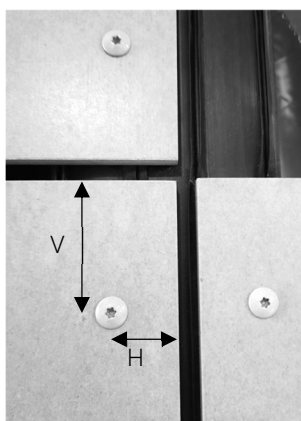

	$H_{\text{min-max}}$	$V_{\text{min-max}}$	Fixed Point	Sliding point
Ornimat, Decoboard, Puro Plus	30 – 100 mm	70 – 100 mm	$\varnothing 5\text{ mm}$	$\varnothing 9,5\text{ mm}$
Colormat	30 – 100 mm	70 – 100 mm	$\varnothing 5\text{ mm}$	$\varnothing 9,5\text{ mm}$

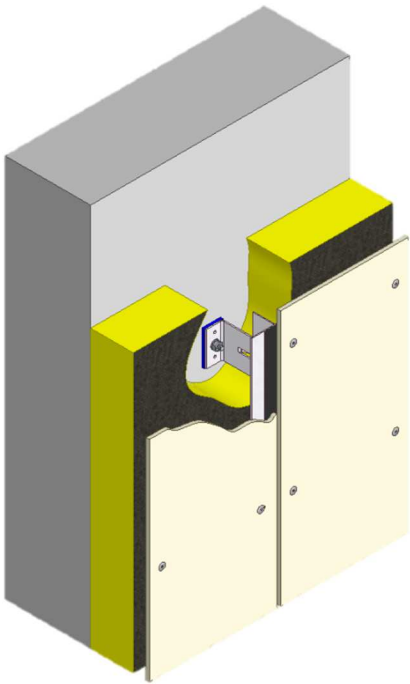

Legende

1.	SVK Façade panel
2.	Insulation
3.	Supporting internal skin
10.	Metal substructure
11.	Rivet
15.	Ventilation profile
26.	Thermal break

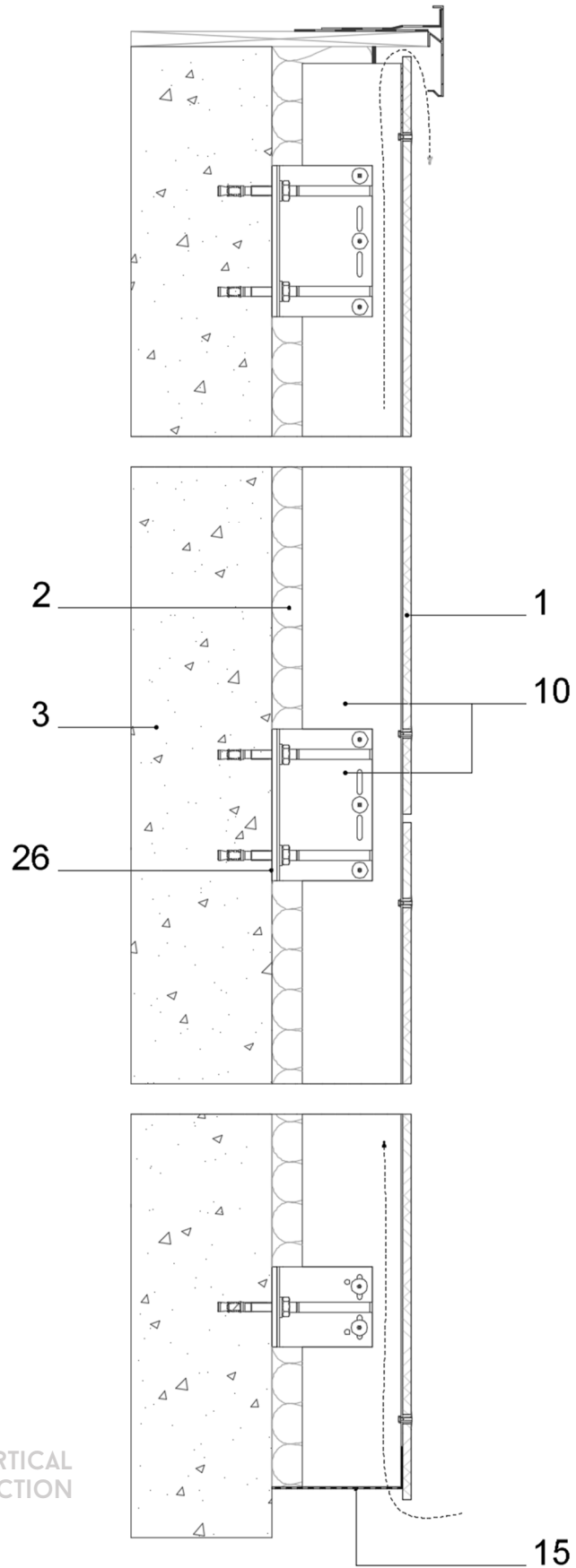

VERTICAL SECTION

Legende

1.	SVK Façade panel
2.	Insulation
3.	Supporting internal skin
8.	Bracket
10.	Metal substructure
11.	Rivet
18.	Corner profile All drill holes in the corner profile should be slotted holes, the fixing points are sliding points, centralized in the slotted holes
26.	Thermal break

HORIZONTAL SECTION

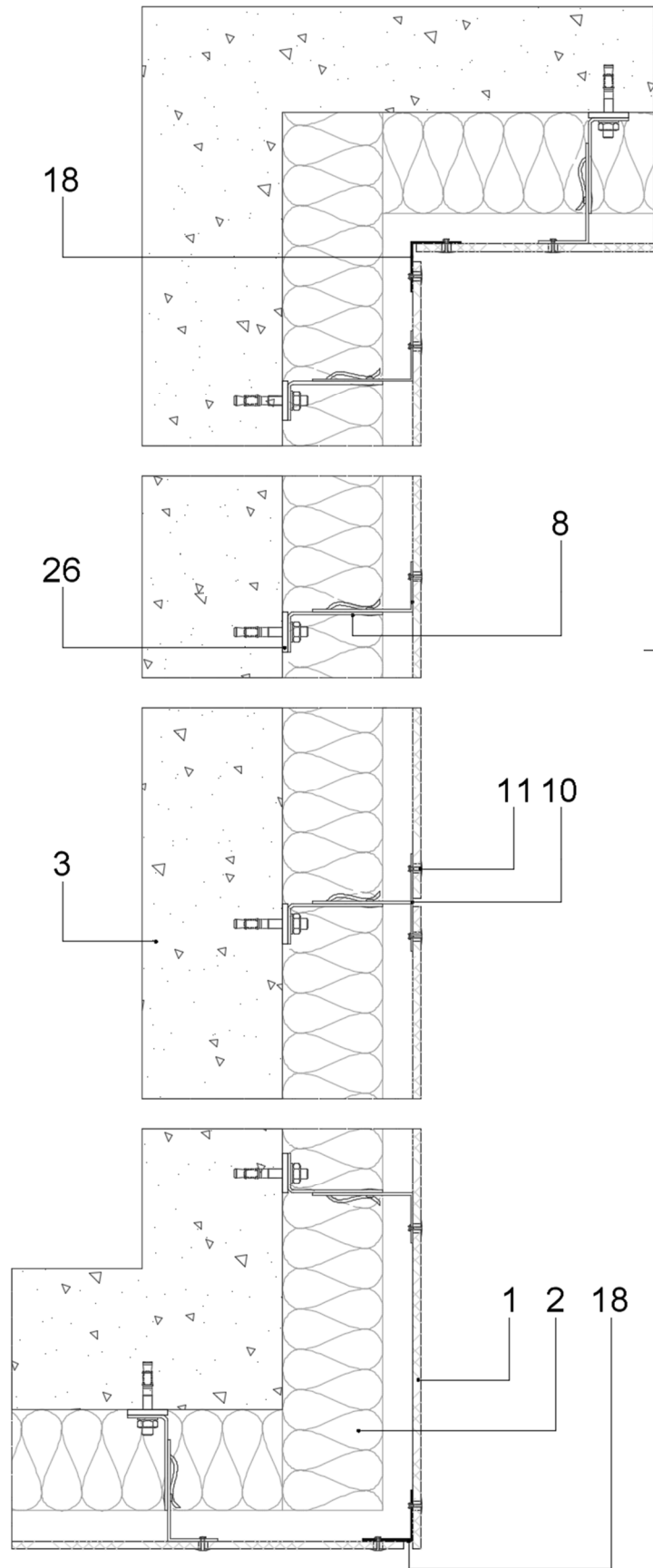

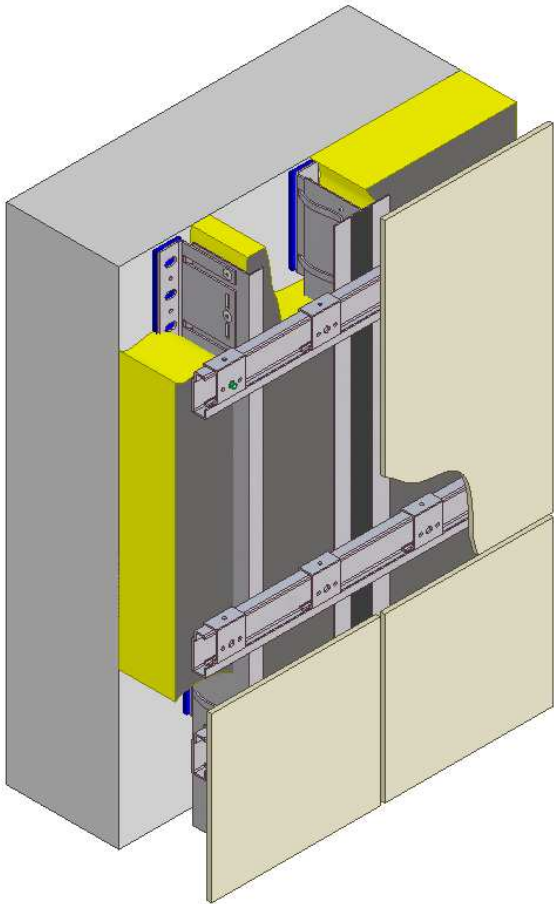

Legende

1.	SVK Façade panel
2.	Insulation
3.	Supporting internal skin
10.	Metal substructure
12.	Panel Hanger
13.	Undercut anchor
14.	Horizontal rail
15.	Ventilation profile
26.	Thermal break

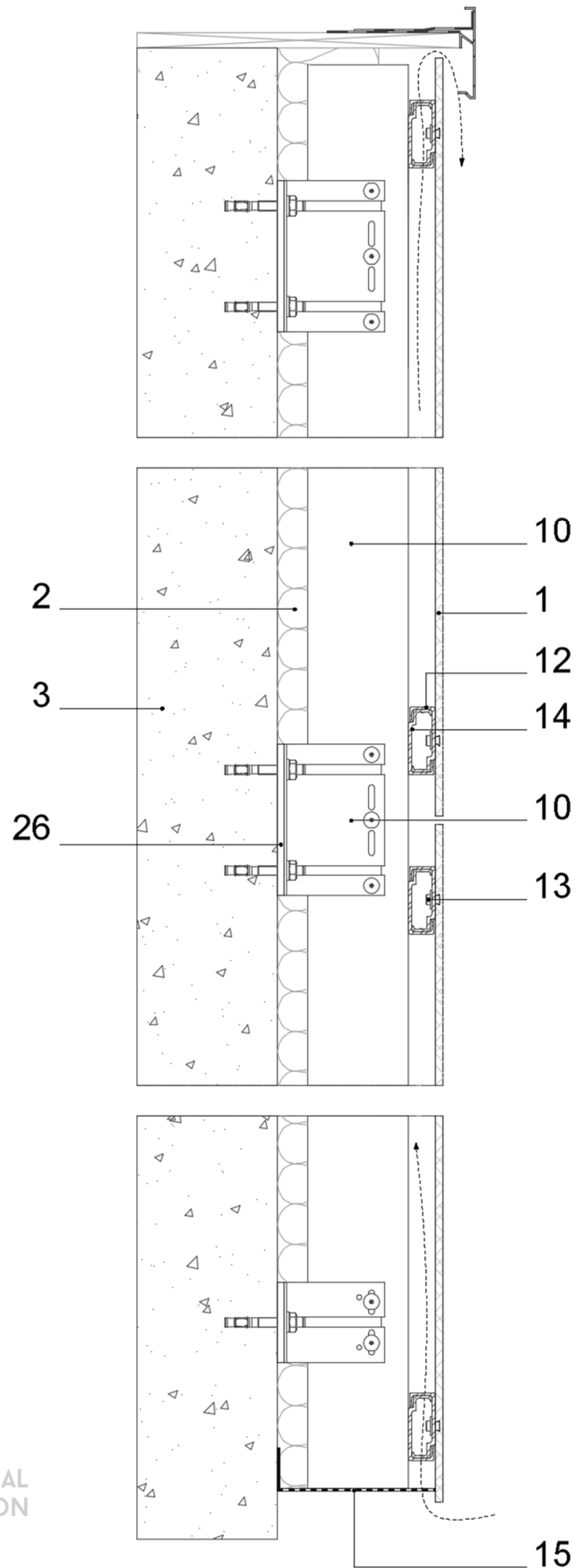

VERTICAL SECTION

Legende

1.	SVK Façade panel
2.	Insulation
3.	Supporting internal skin
8.	Bracket
10.	Metal substructure
12.	Panel Hanger
13.	Undercut anchor
14.	Horizontal rail
18.	Corner profile All drill holes in the corner profile should be slotted holes, the fixing points are sliding points, centralized in the slotted holes
26.	Thermal break

HORIZONTAL SECTION

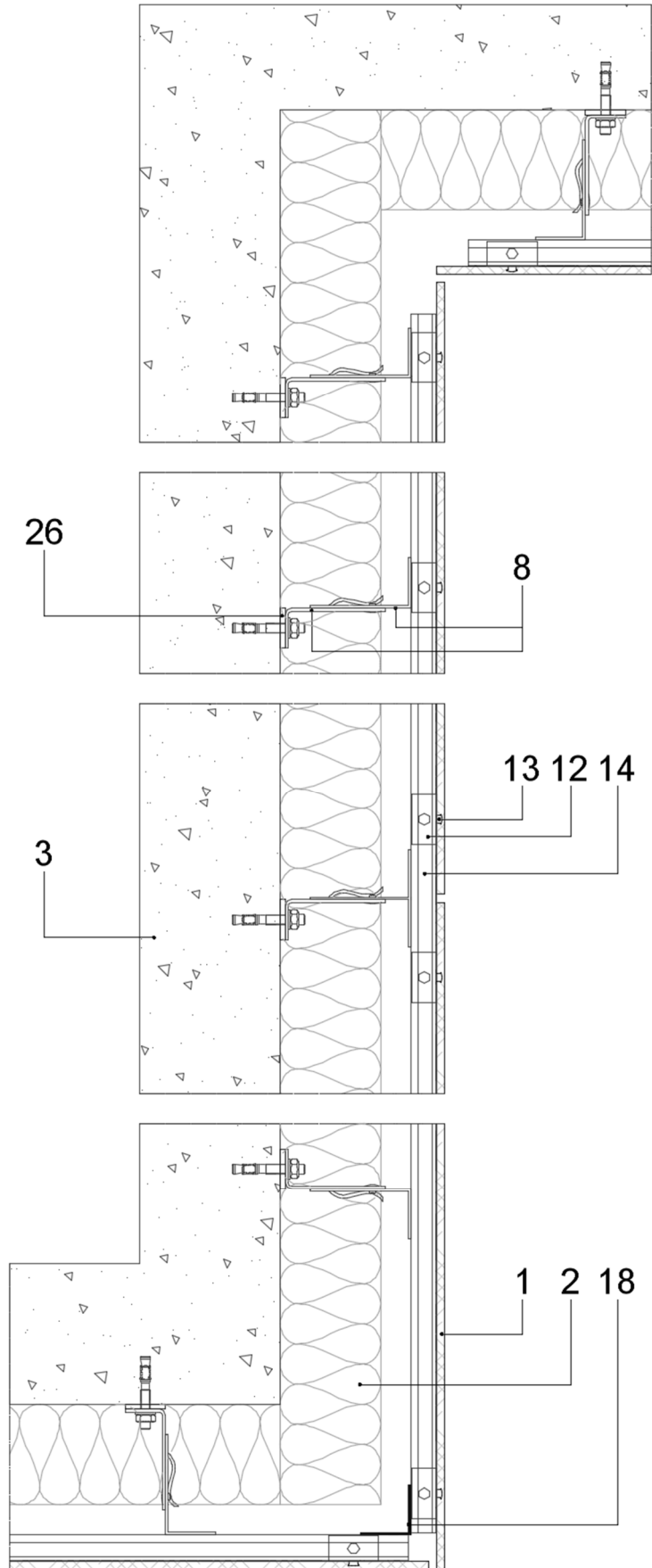

CONNECTION DETAILS

VENTILATION – AIR INLET BOTTOM

Good ventilation consists of three elements:

1. An air inlet at the bottom
2. An air cavity behind the façade panels
3. An air outlet at the top

Only the combination of these three elements creates a ventilation flow, the 'chimney effect'.

In theory, the opening at the bottom should be at least 1 cm wide. However, in practice there is often a greater risk of dirt accumulation at ground level, which prevents ventilation. In practice, it is best to provide an opening of 2 cm to even 5 cm.

The air cavity can be closed at the bottom with a perforated ventilation profile. This way no mice or birds can crawl into the cavity.

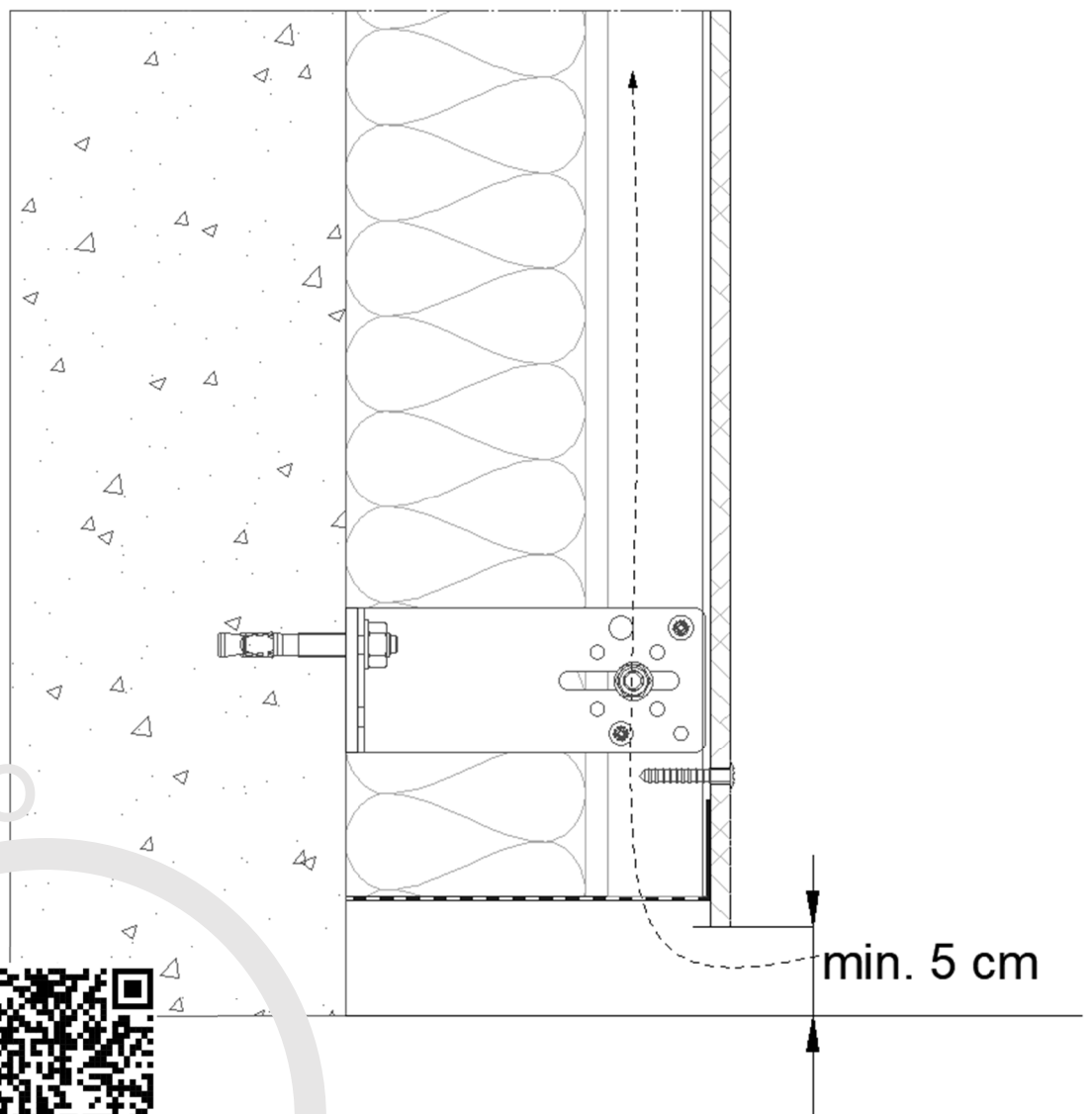

[HTTPS://YOUTU.BE/DN974IIEYI](https://youtu.be/DN974IIEYI)
[Q?SI=Y_VUJTK5_QSDLVRP](https://youtu.be/DN974IIEYI?si=y_vujtk5_qsd1vrp)

HOW TO - VIDEO

The opening at the top must be at least 2 cm wide. Because the roofing work is often carried out by a different party than the cladding work, the necessary checks must be carried out to ensure proper execution. The roof edge profile may in no way fit against the façade panels.

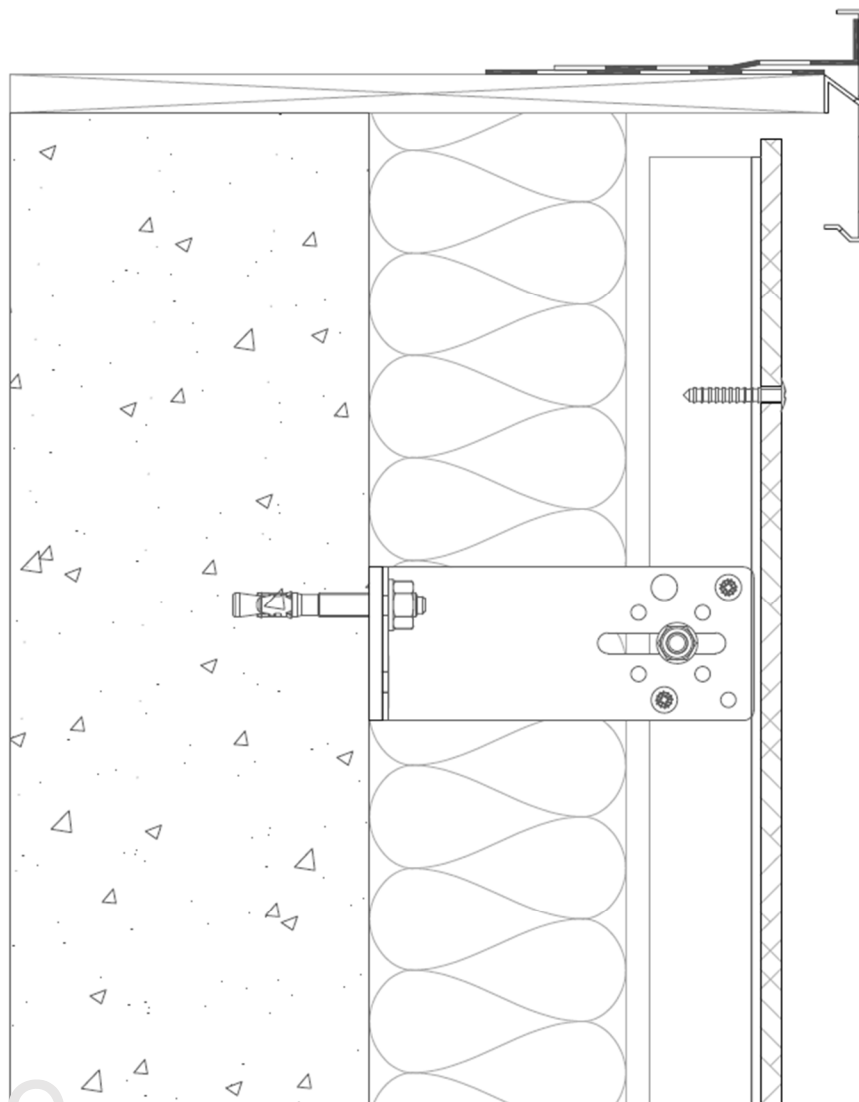

HOW TO - VIDEO



[HTTPS://YOUTU.BE/ZGX4P88IH5I?SI=RFERM7PJLOQN3CW](https://youtu.be/ZGX4P88IH5I?si=RFERM7PJLOQN3CW)

Always provide an expansion joint of at least 8mm if the façade panels connect to another element such as a brick wall, a garden house with wooden cladding...

If desired, for aesthetic reasons, this joint can be finished with a joint profile.

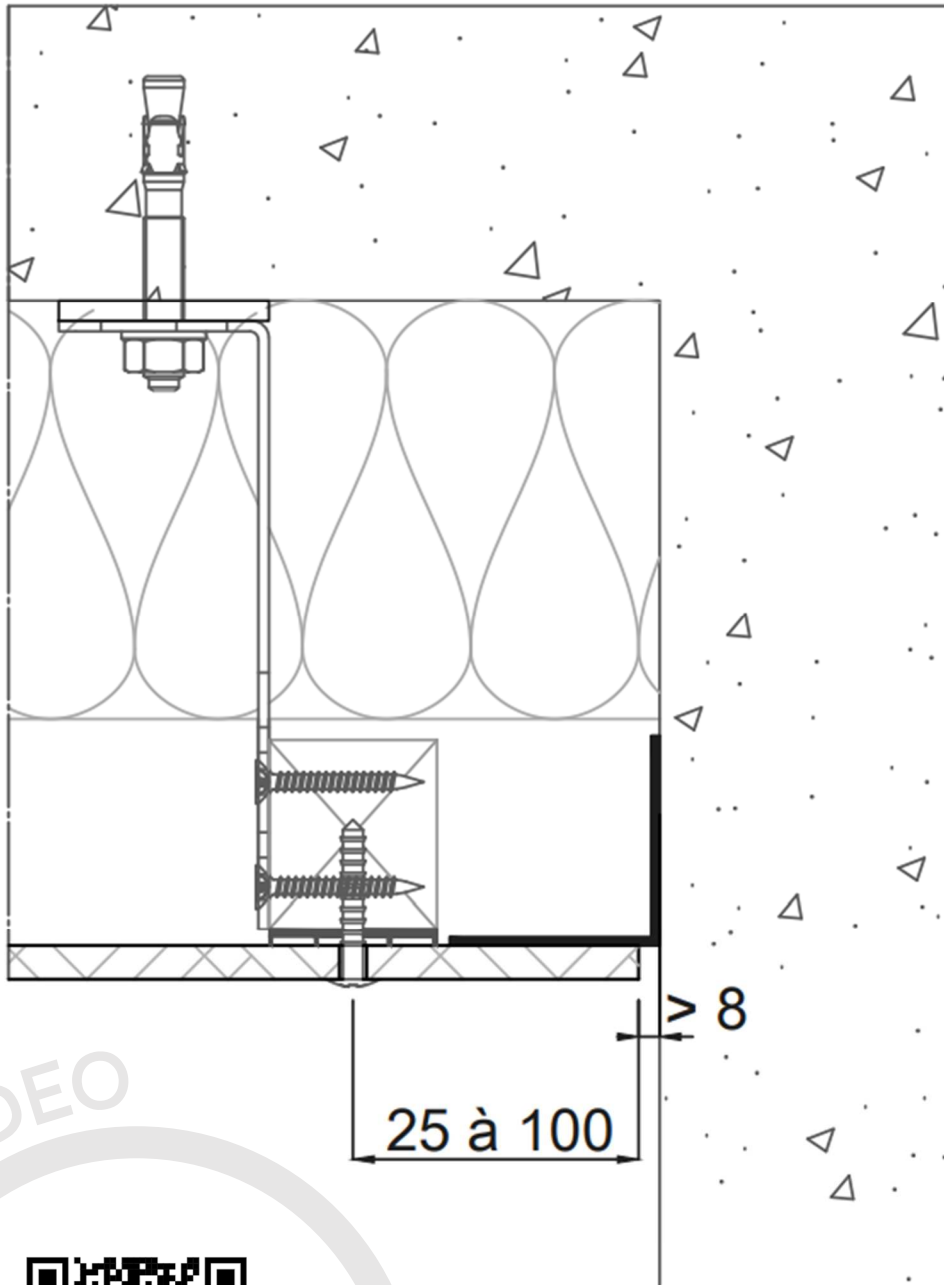

HOW TO - VIDEO



[HTTPS://YOUTU.BE/CPK97BUJM_A?SI=9Q110SHQWIL092R](https://youtu.be/CPK97BUJM_A?si=9Q110SHQWIL092R)

Always provide an expansion joint of at least 8mm when finishing an inner corner. Otherwise, changing weather conditions may cause the panels to expand against each other, resulting in possible breakage.
If desired, for aesthetic reasons, this joint can be finished with a joint profile.

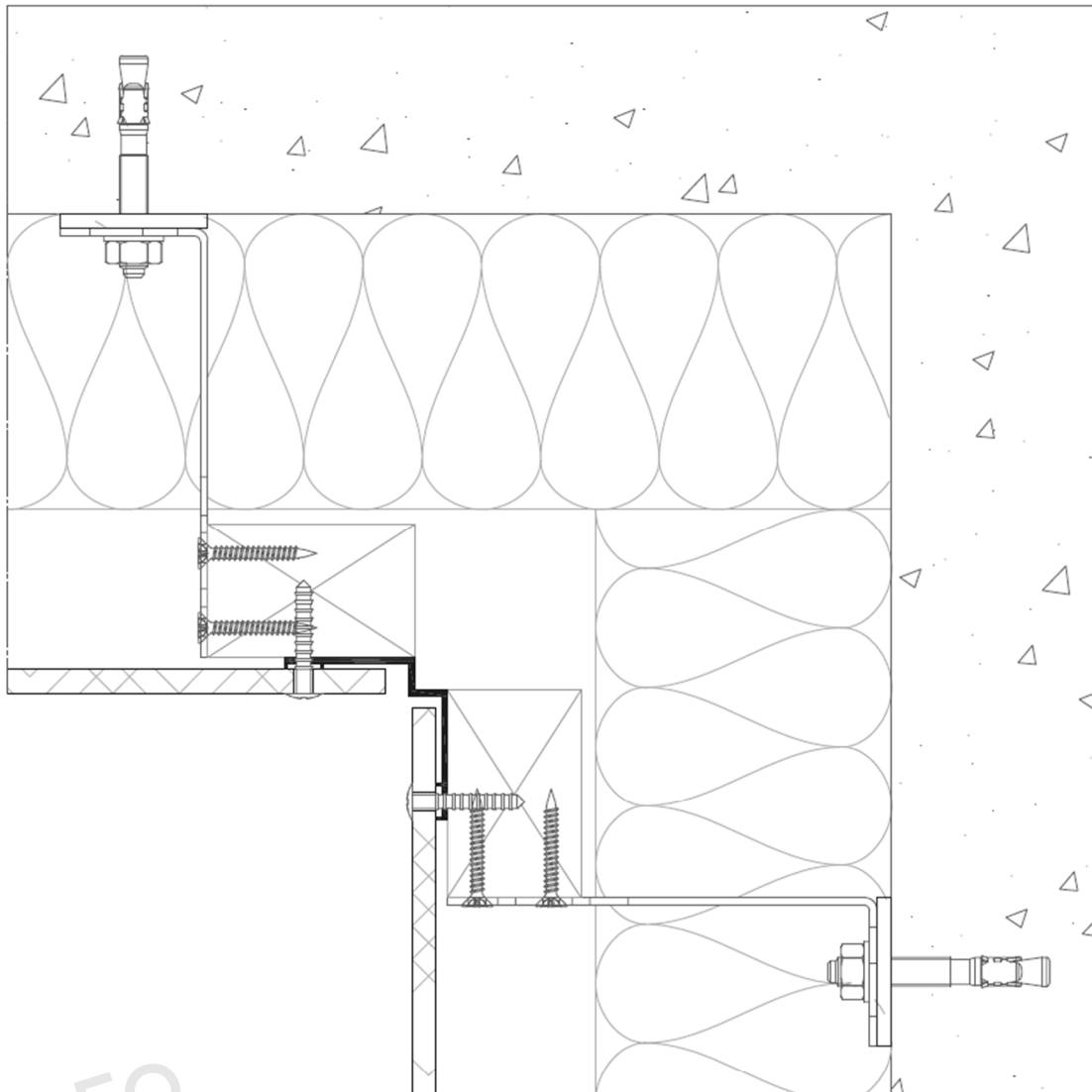

HOW TO - VIDEO



[HTTPS://YOUTU.BE/CPK97B
LJM_A?SI=0Q11D5HQWILQ
92R](https://youtu.be/CPK97BLJM_A?si=0Q11D5HQWILQ92R)

Always provide an expansion joint of at least 8mm when finishing an outside corner. Otherwise, changing weather conditions may cause the panels to expand against each other, resulting in possible breakage.

The wooden supporting structure must be protected against moisture - just like intermediate posts in the façade surface. This can be done with an EPDM joint strip or an angle profile.

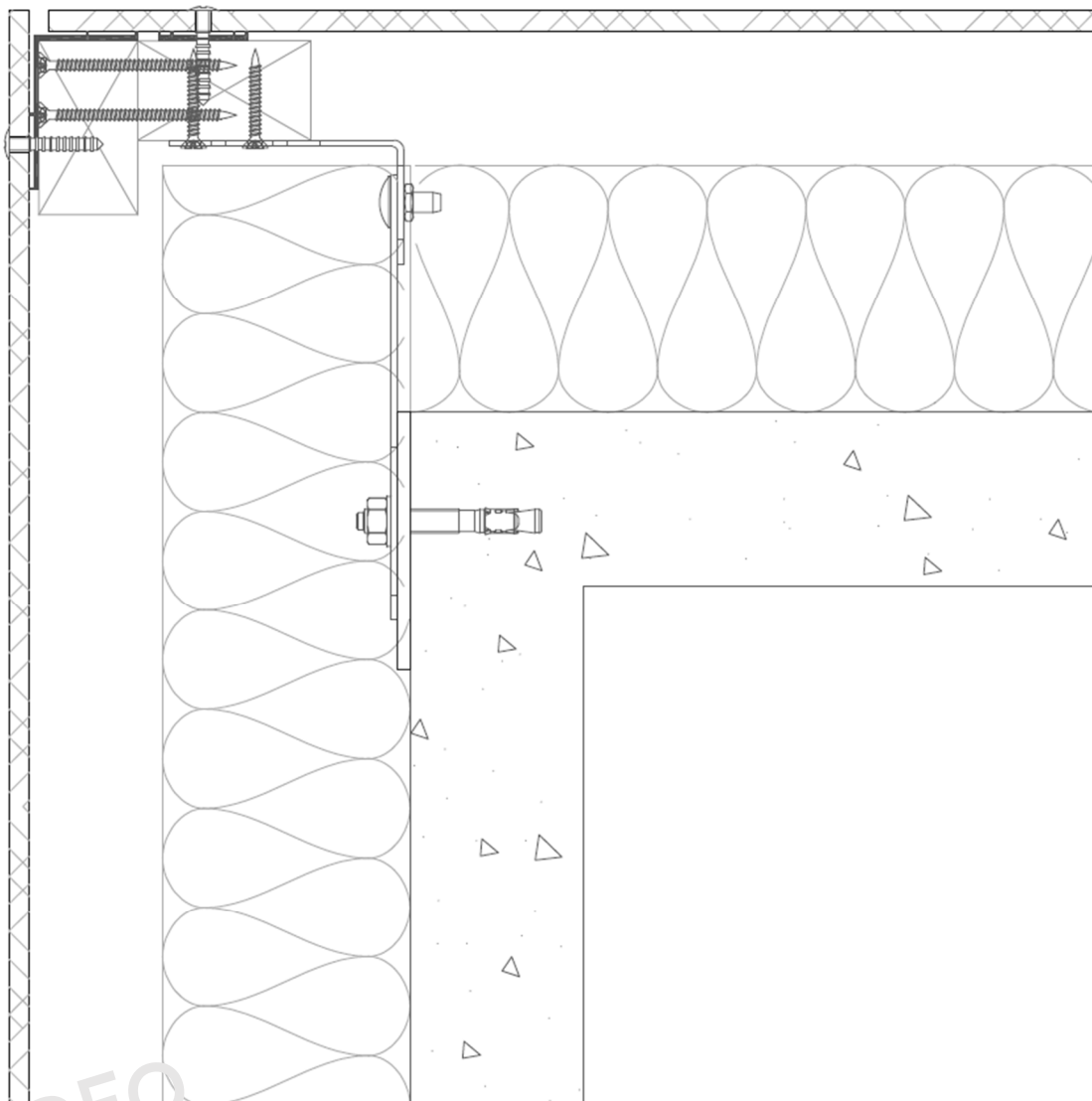

[HTTPS://YOUTU.BE/HPQJBB
PUQ1M?SI=B0QF4LYLAW_E
VOIL](https://youtu.be/HPQJBBPUQ1M?si=B0QF4LYLAW_EVOIL)

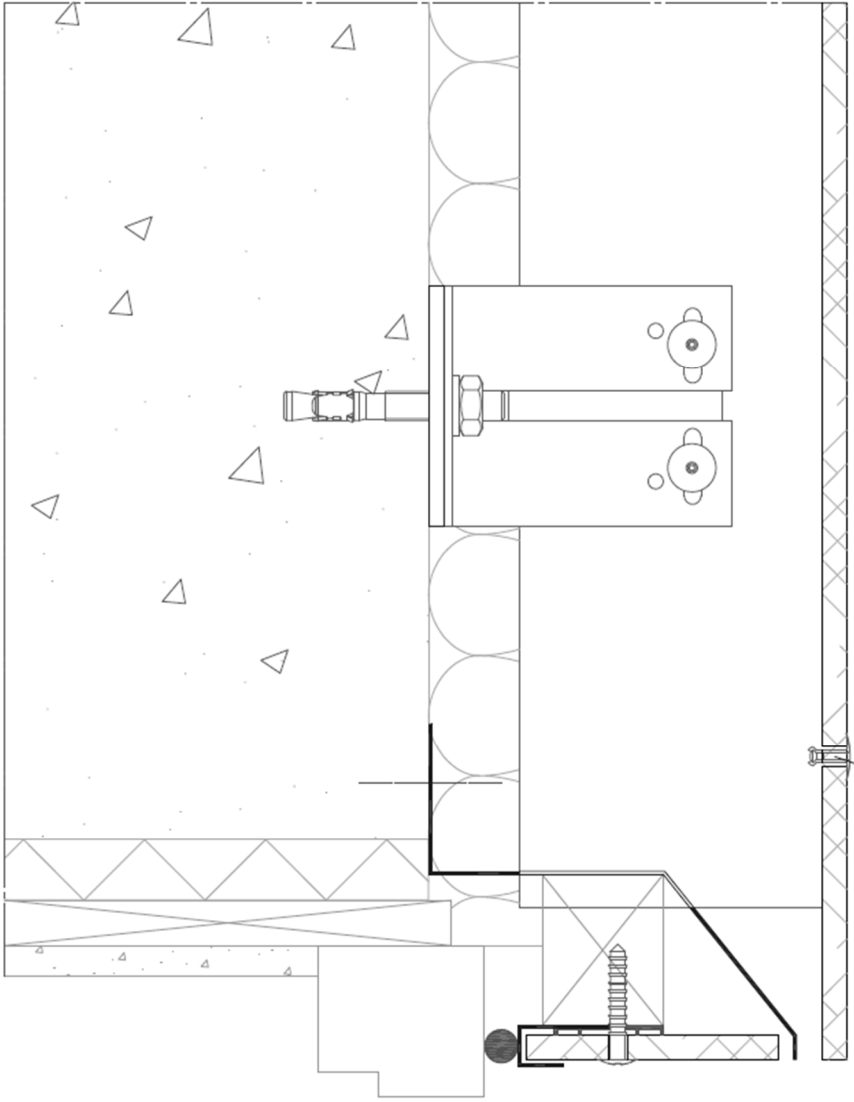

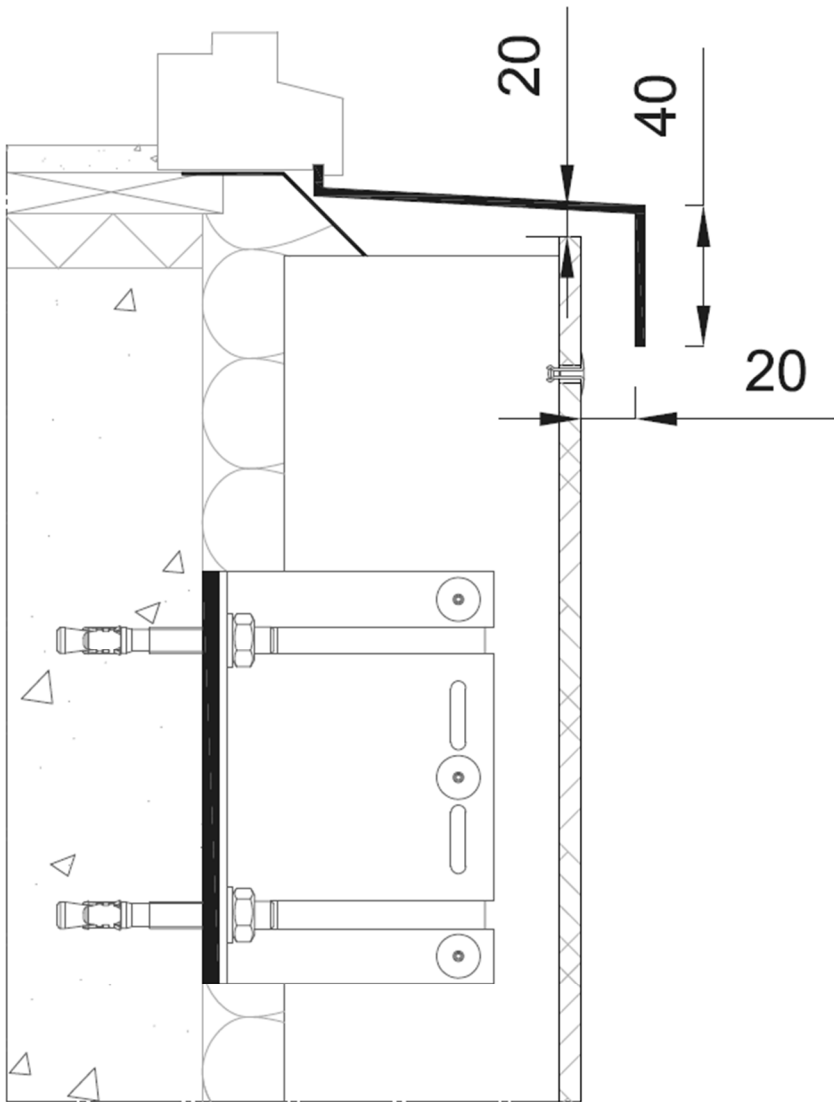

HOW TO - VIDEO



[HTTPS://YOUTU.BE/MRCSCB8YQF0?SI=R3JHDESCZ-A0GCSQ](https://youtu.be/MRCSCB8YQF0?si=R3JHDESCZ-A0GCSQ)

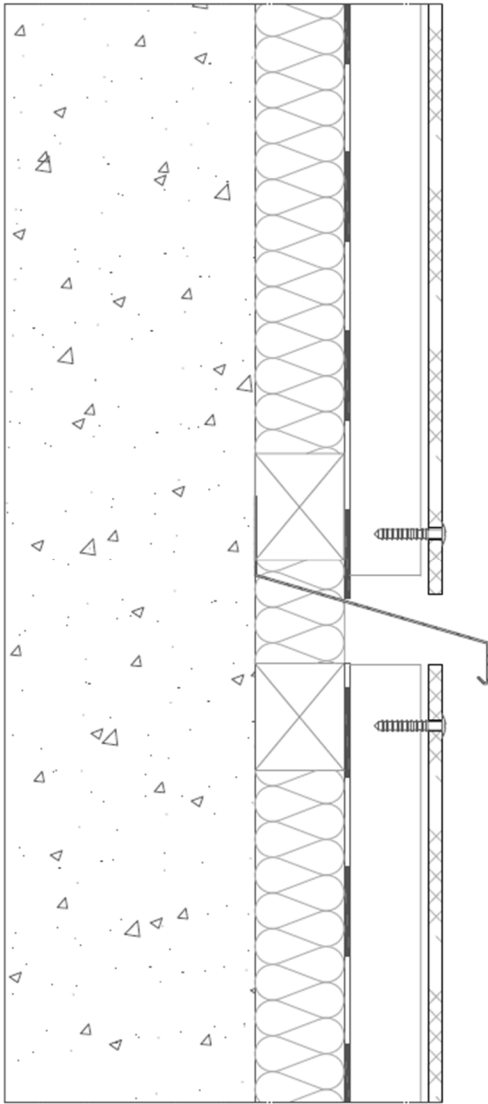

ANNEX ES

ANNEX 1 – GUIDE VALUES FOR SUPPORT- & FIXING DISTANCES

UNITED KINGDOM

The support- and fixing distances depend on the windload and terrain categories, the panel format (2 or more supports, 2 or more fixing rows) and the building height.

As every specific situation requires its own specific measures, the support distances must be calculated for each project.

The windzones and terrain categories for United Kingdom are defined in BS EN 1991-1-4 and the national annex.

Windzone

I	$v_{b,map} < 21 \text{ m/s}$
II	$v_{b,map} = 21 \text{ to } 23 \text{ m/s}$
III	$v_{b,map} = 23 \text{ to } 25 \text{ m/s}$
IV	$v_{b,map} = 25 \text{ to } 27 \text{ m/s}$
V	$v_{b,map} > 27 \text{ m/s}$

Terrain category

Sea	Terrain category 0 is referred to as Sea
Country	Terrain I and II have been considered together
Town	Terrain II and IV have been considered together

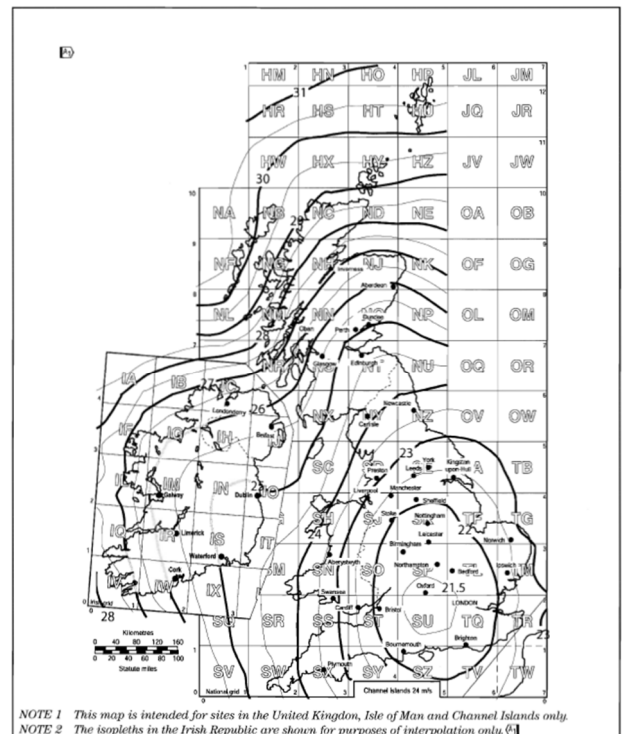

For the determination of the support- and fixing distances the height of the building and altitude of the site must be considered. The maximum support- and fixing distances are determined based on the strength and bending requirements.

The calculation of the support and fixing distances should be done by a calculation bureau.

The table below shows only the maxima that should always be respected for screw and rivet fixing and for the conditions as stated below. These values are not applicable for invisible mechanical fixing with undercut anchor or bending. If higher values are determined by calculation, these should still be reduced to the maxima shown below.

The table is compiled for 2 fixing configurations with edge distances of max. 25 mm.

Terrain height is kept at 0 m, distance to shoreline equals 10 km and the distance inside town equals 1 km.

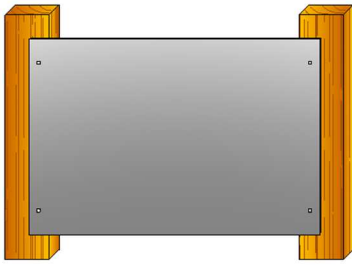

Configuration: 2 x 2

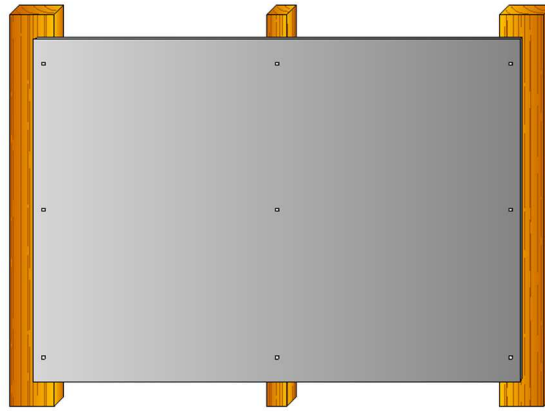

Configuration: 3 x 3

Wind zone	Terrain	Combination	Building height H					
			H ≤ 10m			10m < H ≤ 40m		
			Intermediate distance between screws/rivets					
			600	500	400	600	500	400
I [v _{b,map} = 21 m/s]	Sea	2x2	-	600	600	-	498	600
		3x3	600	600	600	600	600	600
	Country	2x2	-	600	600	-	543	600
		3x3	600	600	600	600	600	600
	Town	2x2	-	600	600	-	541	600
		3x3	600	600	600	600	600	600
II [v _{b,map} = 23 m/s]	Sea	2x2	-	514	600	-	-	519
		3x3	600	600	600	570	600	600
	Country	2x2	-	600	600	-	-	566
		3x3	600	600	600	600	600	600
	Town	2x2	-	600	600	-	-	564
		3x3	600	600	600	600	600	600
III [v _{b,map} = 25,0 m/s]	Sea	2x2	-	-	544	-	-	439
		3x3	598	600	600	483	579	600
	Country	2x2	-	508	600	-	-	479
		3x3	600	600	600	526	600	600
	Town	2x2	-	555	600	-	-	477
		3x3	600	600	600	524	600	600
IV [v _{b,map} = 27 m/s]	Sea	2x2	-	-	466	-	-	377
		3x3	512	600	600	-	497	600
	Country	2x2	-	-	544	-	-	410
		3x3	598	600	600	-	541	600
	Town	2x2	-	-	594	-	-	409
		3x3	600	600	600	-	539	600

EXAMPLE

Windzone I [$v_{b,map} = 21 \text{ m/s}$]; Terrain "Town"; Building height $\leq 10\text{m}$
 Choosing the right dimensions

Wind zone	Terrain		Building height H					
			H $\leq 10\text{m}$			10m < H $\leq 40\text{m}$		
			Intermediate distance between screws/rivets					
I [$v_{b,map} = 21 \text{ m/s}$]	Sea	2x2	-	600	600	-	498	600
		3x3	600	600	600	600	600	600
	Country	2x2	-	600	600	-	543	600
		3x3	600	600	600	600	600	600
	Town	2x2	-	600	600	-	541	600
		3x3	600	600	600	600	600	600

- 2x2 Configuration: It is possible to fixate the panels with 4 fasteners, the maximal intermediate distance between the fixing points is then 600x500mm. Lower intermediate distances are also possible but these require more profiles and reduce the panel sizes

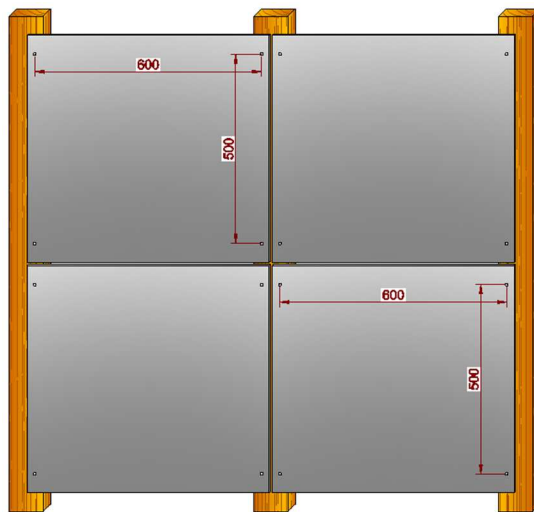

- 3x3 Configuration or more: If the façade panel is installed with 9 or more mountings, this is possible with spacings of 600 x 600 mm. Smaller spacings are also possible, but then the number of profiles of the supporting structure increases and the dimensions of the façade panels become smaller.

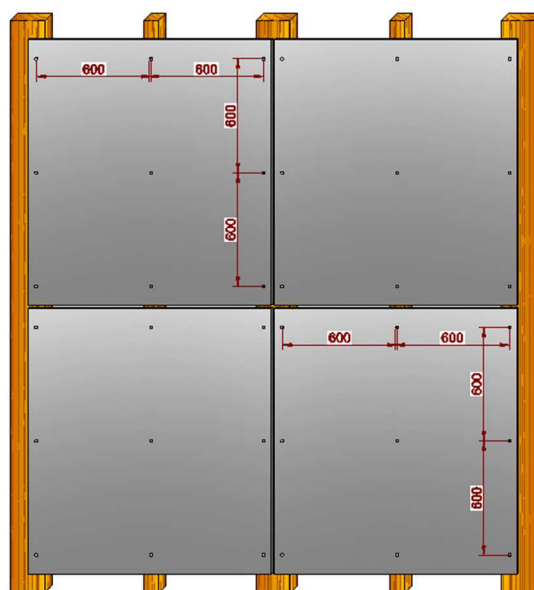

The support and fixing distances depend on the windload and terrain categories, the panel format (2 or more supports, 2 or more fixing rows) and the building height.

As every specific situation its own specific measures requires, the support distances must be calculated for each project.

The windzones and terrain categories for Ireland are defined in I.S. EN 1991-1-4 and the national annex.

Wind zone	
I	ex, map = 25 m/s
II	ex, map = 26 m/s
III	ex, map = 27 m/s
Terrain category	
Sea	Terrain category 0 is referred to as Sea
Country	Terrain I and II have been considered together
Town	Terrain II and IV have been considered together

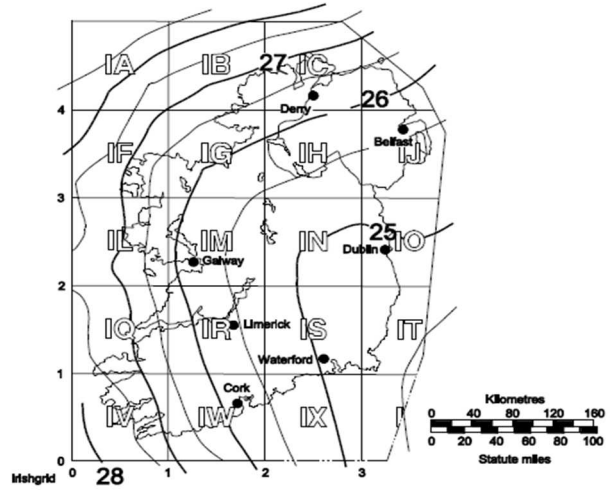

NOTE This map is intended for sites in the Republic of Ireland only. User to reference NA to BS EN 1991-1-4 when designing in Northern Ireland.

Figure NA.1 — Value of fundamental basic wind velocity $v_{b,map}$ (m/s) before the altitude correction is applied

For the determination of the support- and fixing distances the height of the building and altitude of the site must be considered. The maximum support- and fixing distanced are determined based on the strength and bending requirements.

The calculation of the support and fixing distances should be done by a calculation bureau.

The below given table shows only the maxima that should always be respected for screw and rivet fixing and for the conditions as stated below. These values are not applicable for invisible mechanical fixing with undercut anchor or bending.

If higher values are determined by calculation, these should still be reduced to the maxima shown below.

The table is compiled for 2 fixing configurations with edge distances of max. 25 mm.

Terrain height is kept at 0 m, distance to shoreline equals 10 km and the distance inside town equals 1 km.

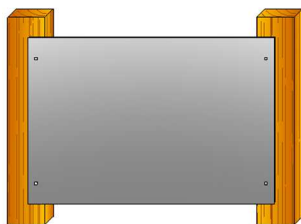

Configuration: 2 x 2

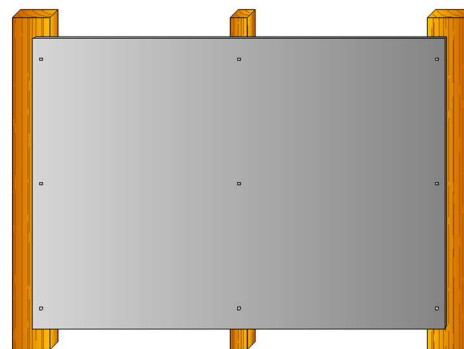

Configuration: 3 x 3

Wind zone	Terrain	Combination	Building height H					
			H ≤ 10m			10m < H ≤ 40m		
			Intermediate distance between screws/rivets					
			600	500	400	600	500	400
I [v _{b,map} = 25,0 m/s]	Sea	2x2	-	-	544	-	-	439
		3x3	598	600	600	483	579	600
	Country	2x2	-	508	600	-	-	479
		3x3	600	600	600	526	600	600
	Town	2x2	-	555	600	-	-	477
		3x3	600	600	600	524	600	600
I [v _{b,map} = 26,0 m/s]	Sea	2x2	-	-	503	-	-	477
		3x3	600	600	600	526	600	600
	Country	2x2	-	-	587	-	-	443
		3x3	600	600	600	487	584	600
	Town	2x2	-	513	600	-	-	441
		3x3	600	600	600	485	582	600
III [v _{b,map} = 27 m/s]	Sea	2x2	-	-	466	-	-	377
		3x3	512	600	600	-	497	600
	Country	2x2	-	-	544	-	-	410
		3x3	598	600	600	-	541	600
	Town	2x2	-	-	594	-	-	409
		3x3	600	600	600	-	539	600

EXAMPLE

Wind zone I [v_{b,map} = 25 m/s]; Terrain "Town"; Building height > 10m
 Choosing the right dimensions

Wind zone	Terrain	Combination	Building height H					
			H ≤ 10m			10m < H ≤ 40m		
			Intermediate distance between screws/rivets					
			600	500	400	600	500	400
I [v _{b,map} = 25,0 m/s]	Sea	2x2	-	-	544	-	-	439
		3x3	598	600	600	483	579	600
	Country	2x2	-	508	600	-	-	479
		3x3	600	600	600	526	600	600
	Town	2x2	-	555	600	-	-	477
		3x3	600	600	600	524	600	600

2x2 Configuration: It is possible to fixate the panels with 4 fasteners, the maximal intermediate distance between the fixing points is then 477x400mm. Lower intermediate distances are also possible but these require more profiles and reduce the panel sizes.

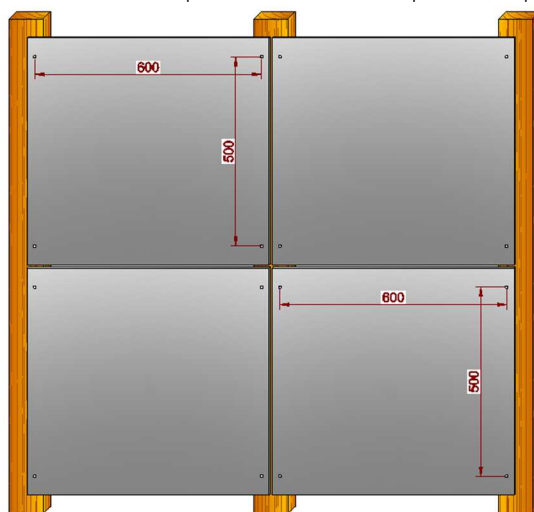

3x3 Configuration or more: If the panels are fixated with 9 or more fasteners then it is possible to have a maximal intermediate distance of 600x524mm. Lower intermediate distances are also possible but these require more profiles.

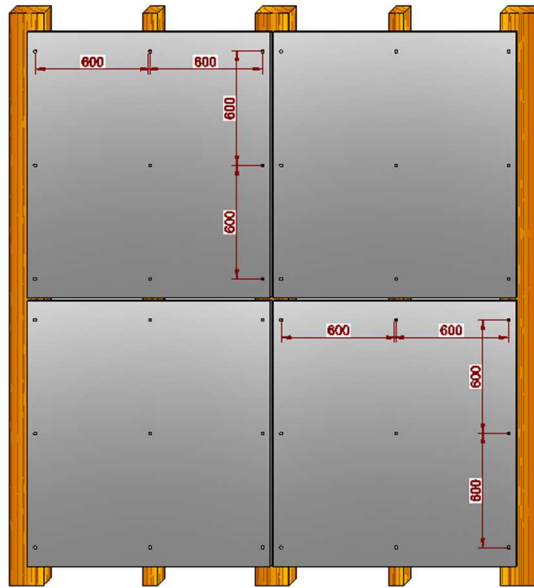

ANNEX 2 – IMPACT RESISTANCE

SVK façade panels Ornimat, Decoboard and Puro Plus resist an impact with a hard body up to 3 J and an impact with a soft body up to 130 J. SVK Colormat 8mm resist an impact with a soft body up to 100 J (tested according to ISO 7892). If SVK panels are installed in areas where abnormal impact loads are expected, then necessary precautions should be taken.

Where higher resistance is required, a supporting panel should be placed behind the façade panel. Contact our Technical Department on this occasion.

It must be assumed that SVK façade panels are not vandalism resistant.

Table 1 – application category (according de ETAG 034-1)

Application category	Description
I	Ground floor, accessible to the public and fragile for impact with a hard body but no abnormal heavy usage
II	Zone exposed to impacts of thrown or shot objects, in public domain where the height of the kit limits the impact, or low level where the access is limited to maintenance work only.
III	Zone that does not get damaged by normal impact or impact by thrown or shot objects.
IV	Zone outside the reach of the ground floor

Table 2 - Impact category

Impact hard	Category			
	IV	III	II	I
1 joule	Façade element not torn ⁽²⁾	-	-	-
3 joule	-	Façade element not torn ⁽²⁾	No degradation ⁽¹⁾	No degradation ⁽¹⁾
10 joule	-	-	Façade element not torn ⁽²⁾	No degradation ⁽¹⁾
soft				
10 joule	No degradation ⁽¹⁾	No degradation ⁽¹⁾	-	-
60 joule	-	-	No degradation ⁽¹⁾	No degradation ⁽¹⁾
300 joule	-	-	No degradation ⁽¹⁾	-
400 joule	-	-	-	No degradation ⁽¹⁾

⁽¹⁾ Superficial damage, if there are no cracks it is not considered as "no degradation"

⁽²⁾ The results are considered as "torn" if a circle shaped penetration is noted.