

# Installation guide

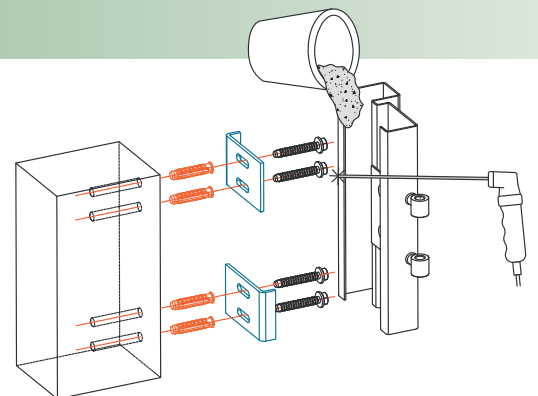

## Installation and adjustment

MPHE 0000 : METAL+ | SWING DOOR | FITTED IN TUNNEL,  
MORTARED FRAME





# TABLE OF CONTENTS

<b><u>CAPTIONS</u></b> .....	4
------------------------------	---

<b><u>PRECAUTIONS</u></b> .....	5
---------------------------------	---

## **INSTALLATION: FITTED IN TUNNEL**

Preparing the frame .....	6
Installing the leaf.....	10
Applying the sealing mortar .....	13

## **ADJUSTING THE LEAF ONCE THE MORTAR**

### **HAS SET**

Hinges.....	16
Striker plates .....	18
Rods.....	19
Ground sockets .....	20

## **FITTINGS INSTALLATION**

Cylinder .....	21
Door handles.....	22
Anti-panic bar .....	23
Door closer .....	23
Closure selector .....	24

## **FINAL CHECK AND FINISHING**

Tightening the screws .....	25
-----------------------------	----

## **HEINEN WARRANTY**

Heinen warranty .....	26
-----------------------	----

## CAPTIONS



**HORIZONTAL STRAIGHTENING**



**COMPLETE DRYING**



**MOISTURE REMOVAL**



**CLEAN SURFACE**



**INSPECTION**



**VERTICAL STRAIGHTENING**



**PROCEED WITH CARE**



**PRECAUTIONS**



**PROCEDURAL SEQUENCE**

## PRECAUTIONS



### STORAGE PRECAUTIONS

Store all doors, including exterior doors, away from the elements and moisture prior to installation.

Do not expose the blue protective film covering the leaf to the sun.

Poor storage conditions can affect the adhesion of the protective film, making it difficult to remove.

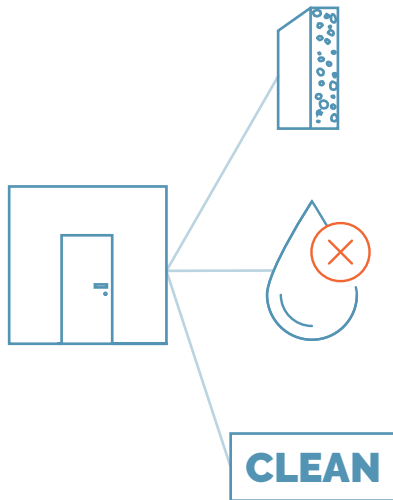

### CONSTRUCTION MEDIUM

Thickness (min. 100 mm), density and resistance vary according to the performance of the door set and must comply with the relevant certificates.

### CORROSION PRECAUTIONS

The wall must be completely dry.

### SEALING MORTAR ADHESION

This depends primarily on the surface condition of the edges of the opening, which must be clean and free of any paint or coatings. Note to builder: it is advisable not to repoint the masonry seals around the narrow sides of the opening in order to improve the adhesion of the sealing mortar.



### MARKING THE FINISHED FLOOR

- With a rough floor: ensure that the finished floor level is clearly marked.
- With a finished floor: check that the floor beneath the leaf and the entire area that the door sweeps when opened is horizontal.

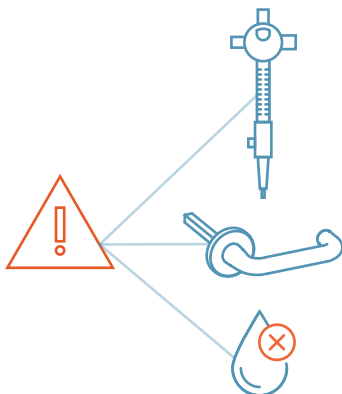

### INSTALLATION PRECAUTIONS

- Always keep at hand an accessory to allow you to open the door during installation.
- Do not use the master key in combination with the Abloy EL520 lock.
- Fire doors must be stored and installed in conditions free of moisture.



### PRECAUTIONS FOR DOORS EXPOSED TO THE ELEMENTS

Any orifices that might be exposed to the elements must be protected with silicone sealant.

# INSTALLATION: FITTED IN TUNNEL

(in the opening / flush)

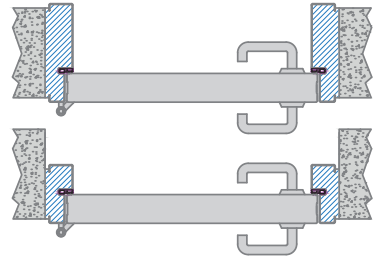

## PREPARING THE FRAME

**1** Place the door frame on the floor

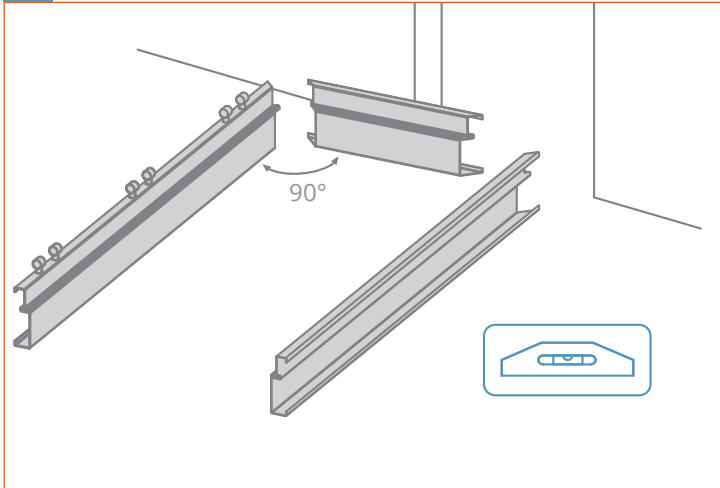

**2** Assemble

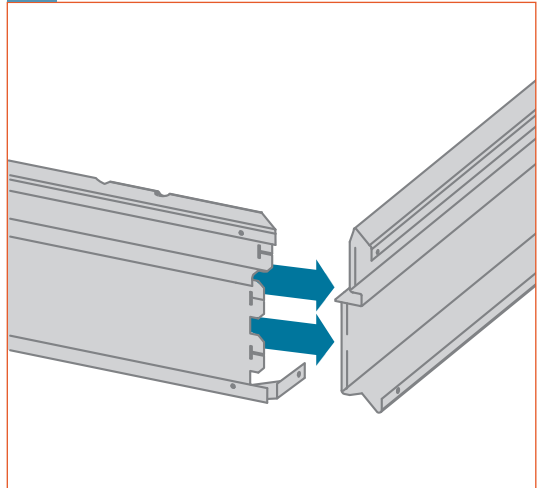

**3** Tighten the screws

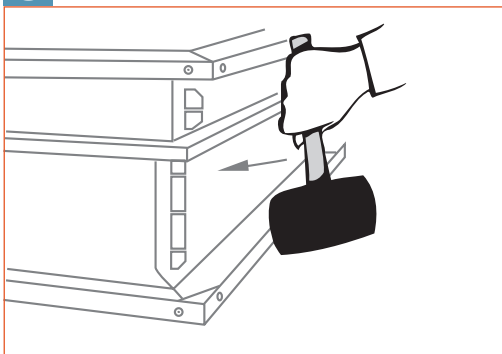

**4** Attach the brackets

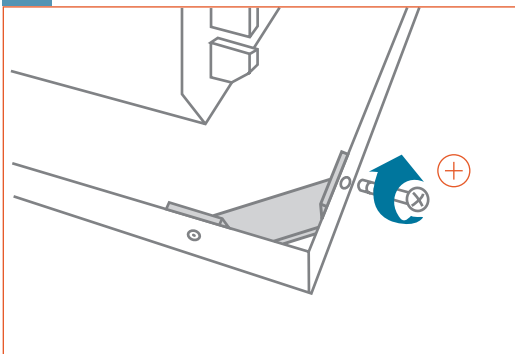

Repeat for  
the 2<sup>nd</sup> frame

**5** Bend the brackets

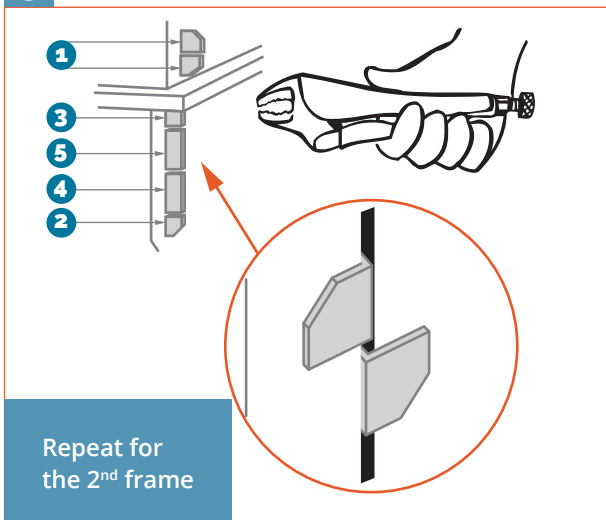

**!** Doors exposed to the elements

All joints (interior and exterior) at the corners of the frame must be caulked with silicone sealant to prevent wet concrete from running.

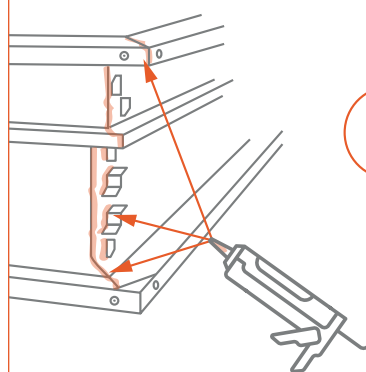

or

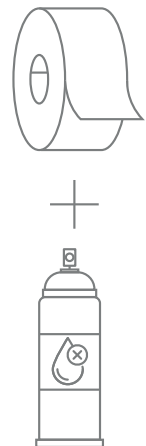

**6** Attach the spacer bar flat on the non-hinge side

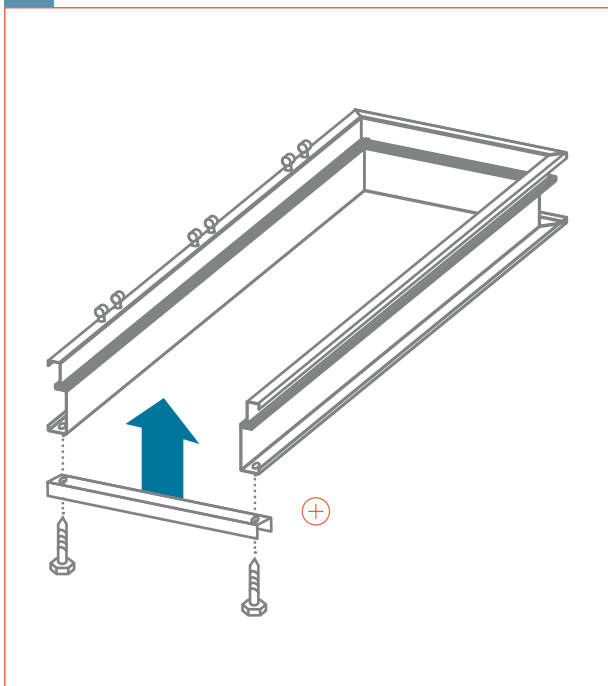

**7a** Attach the metal fitting clamps

Use screws and pins that are suited to the construction medium and in accordance with the following:

- the number stated on the dispatch note;
- the positions indicated in the following point 7b.

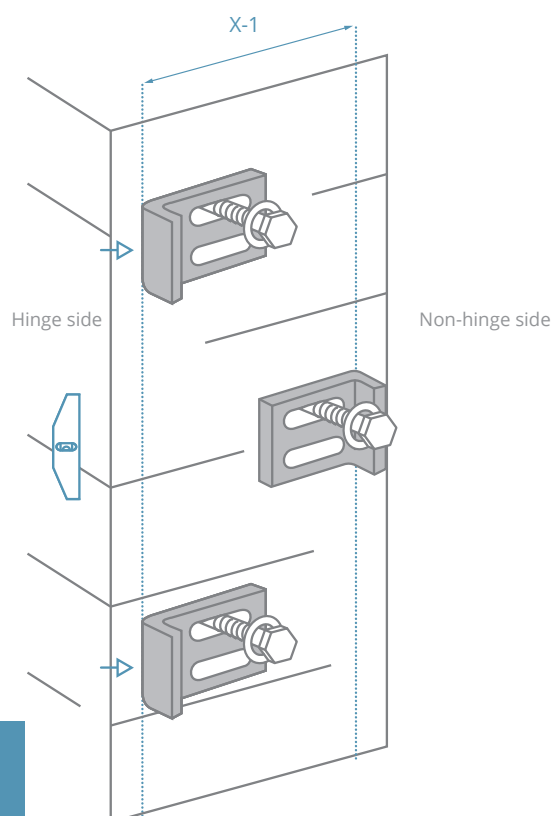

The fitting clamps, if ordered, can be found in the hardware package.

Unless there is a specific requirement, one screw per fixing clamp is sufficient.





Unless there is a specific requirement, the number of fixing clamps must be respected as a minimum.

## 7b Attaching the clamps

### HINGE SURROUND WITH 2 HINGES

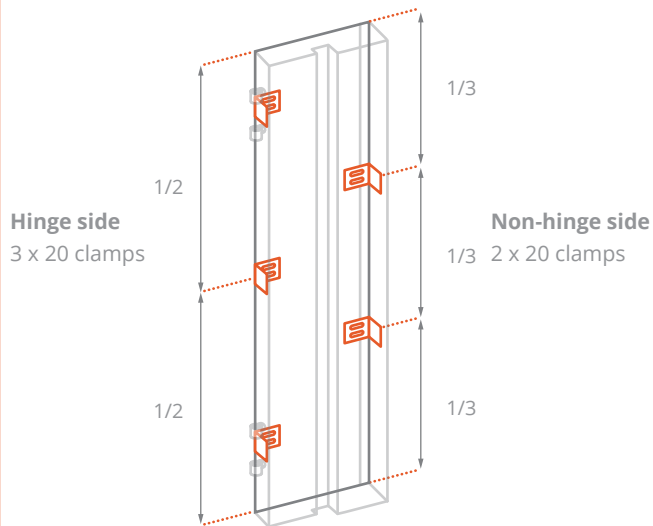

### HINGE SURROUND WITH 3 OR MORE HINGES

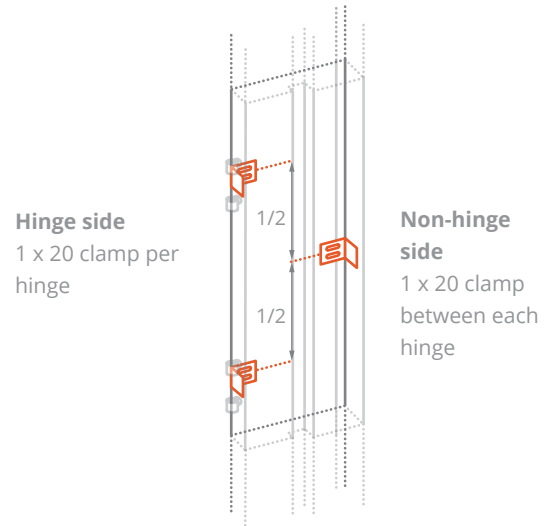

### LOCK SURROUND

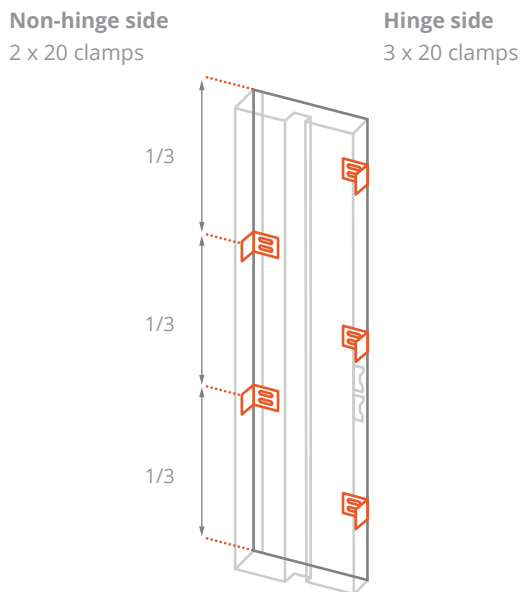

### HIGH SURROUND FOR DOUBLE DOORS

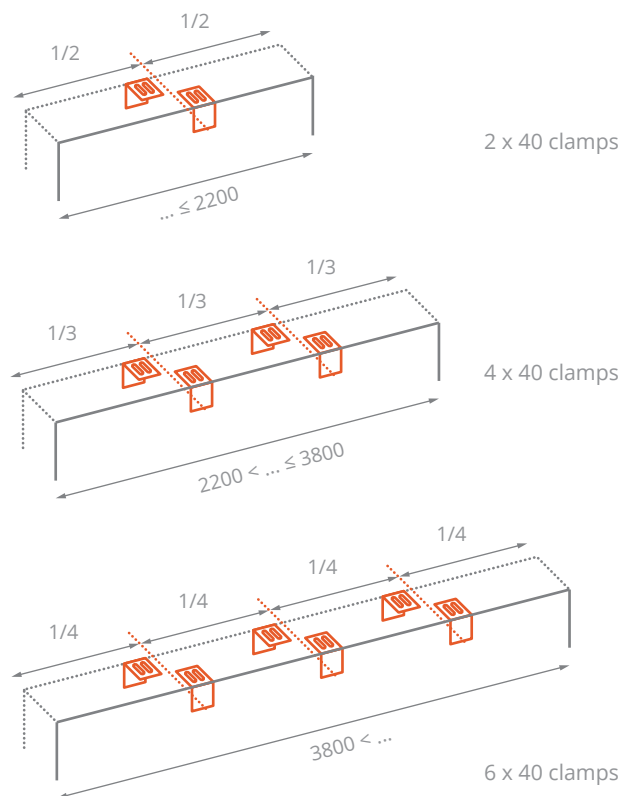



Take care to protect any flammable elements when welding the clamps.

**8**

Position the door frame level to and at the correct height from the finished floor.

Adjust the fitting clamps to the appropriate level if necessary.

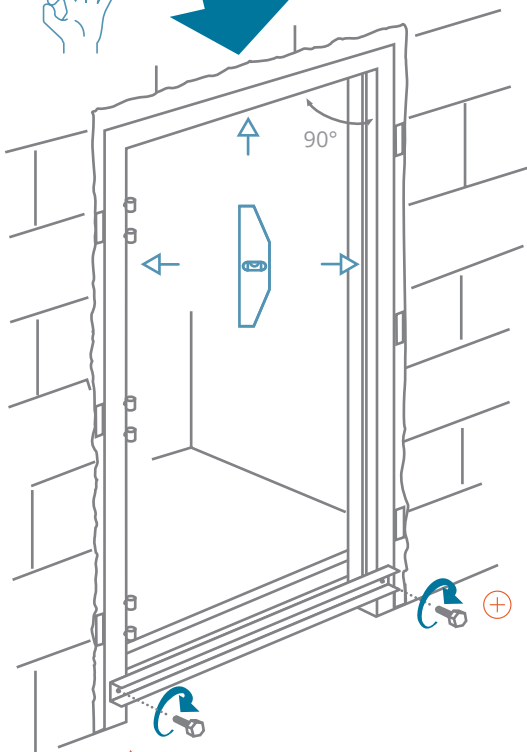

Attach the hinge spacer bar

**9**

Marking



Spot weld the 2 top and bottom hinge clamps only

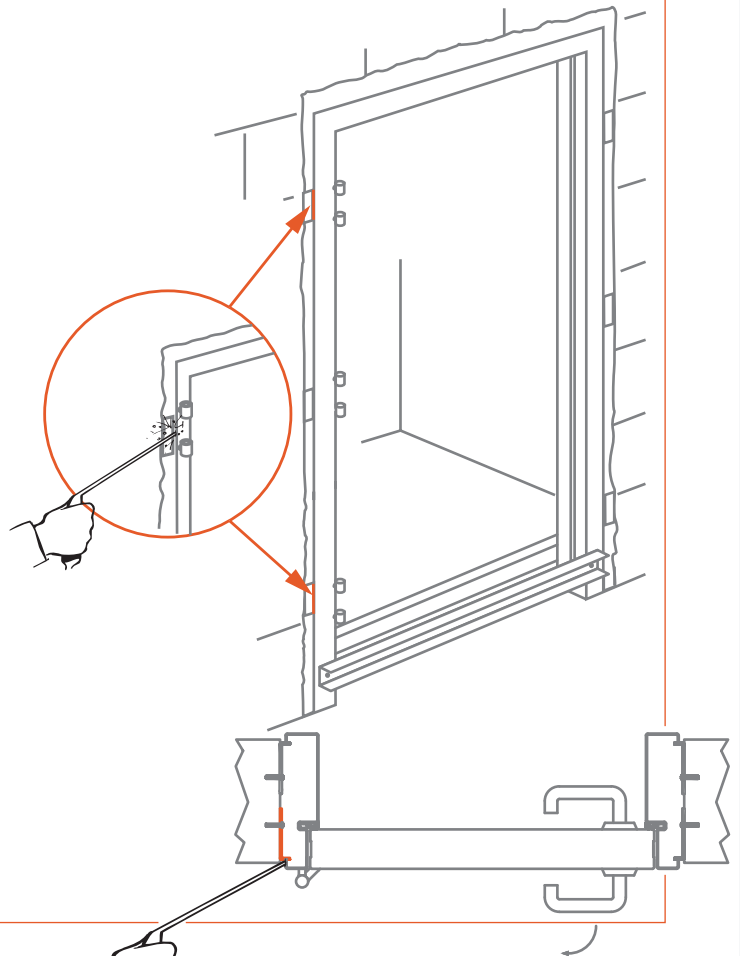

**10**

Remove the hinge-side spacer bar

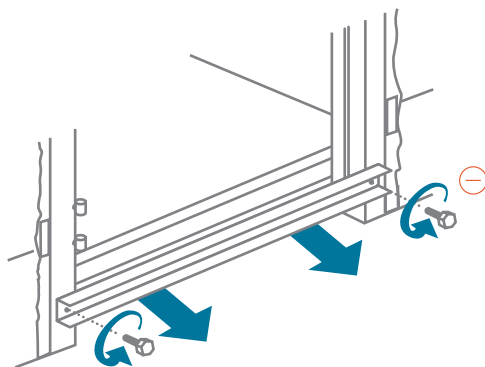

## INSTALLING THE LEAF

- 1** Remove the wire holding the factory-preset hinges in place

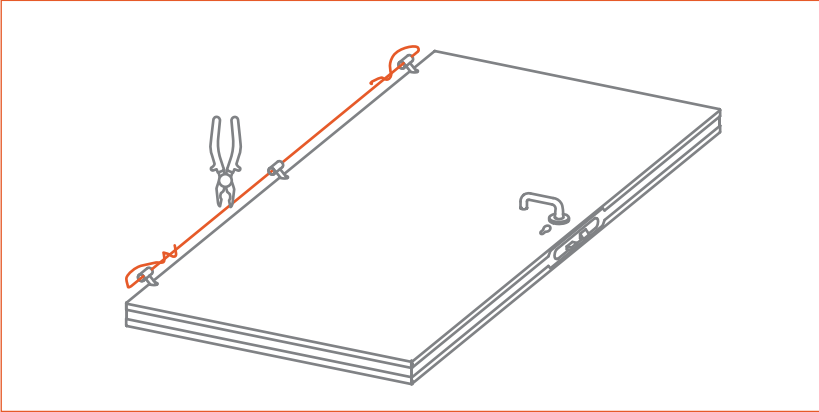

- 2** Install the leaf/leaves and tighten the hinge pin screws firmly

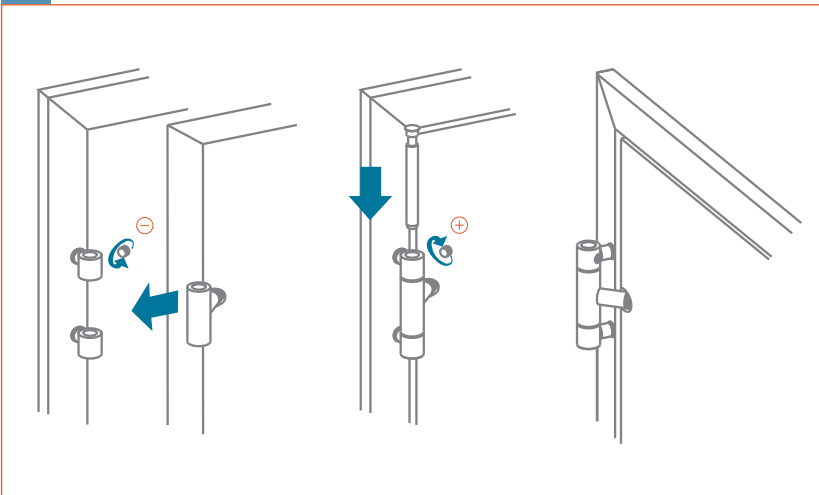

- 3** Replace the hinge-side spacer bar

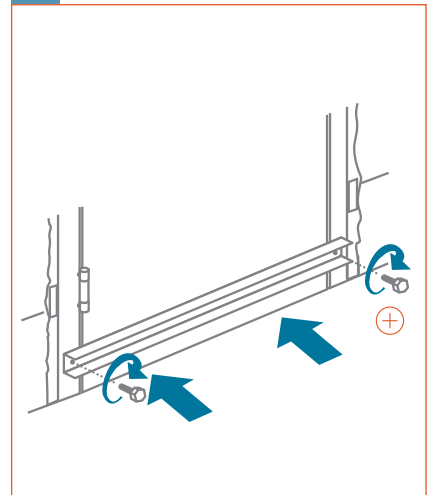

- 4** Door fitted with spring-loaded cable duct

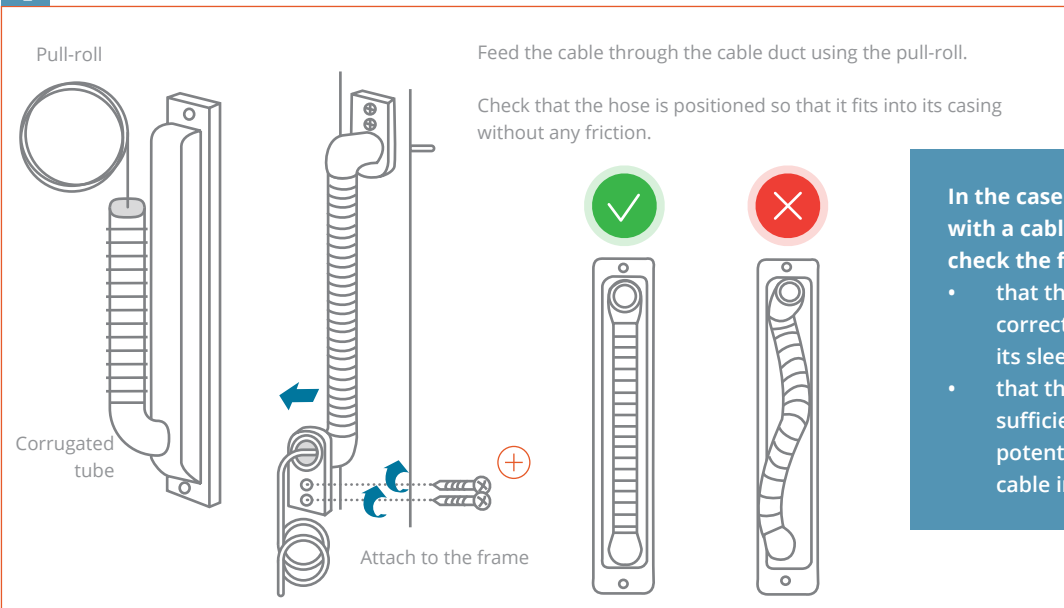

**In the case of doors fitted with a cable duct, always check the following:**

- that the sheath is correctly positioned in its sleeve;
- that the sheath has sufficient flexion for potentially replacing the cable in the future.

**5** Position the shims

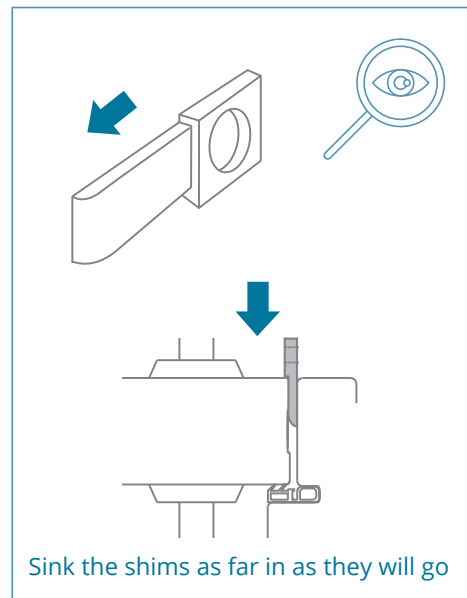
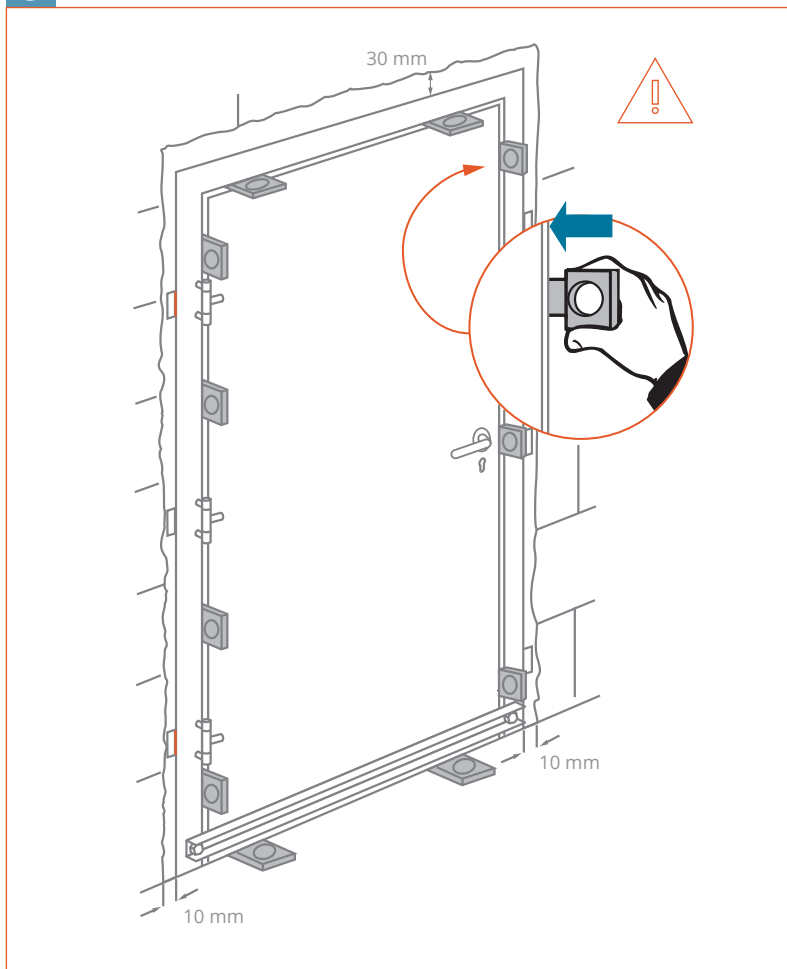

The type of single door kit (1/2) is calculated according to the doors and is indicated on the delivery note

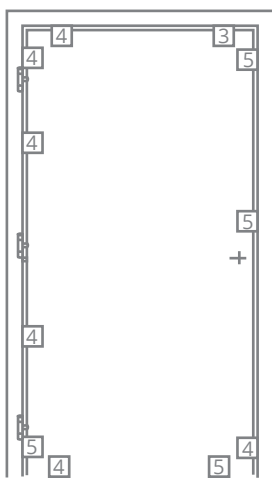

**KIT 1 SINGLE DOOR**

- 1 x 3 mm shim
- 6 x 4 mm shims
- 4 x 5 mm shims
- 0 x 6 mm shims

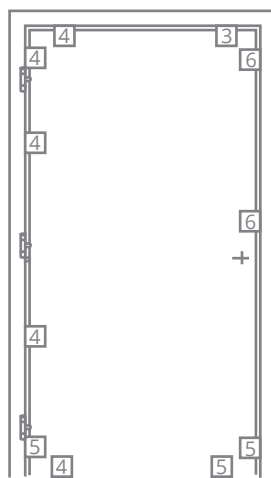

**KIT 2 SINGLE DOOR**

- 1 x 3 mm shim
- 5 x 4 mm shims
- 3 x 5 mm shims
- 2 x 6 mm shims

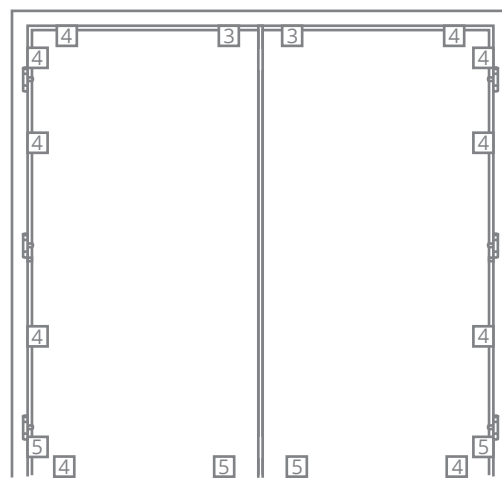

**KIT DOUBLE DOOR**

- 2 x 3 mm shims
- 10 x 4 mm shims
- 4 x 5 mm shims
- 0 x 6 mm shims

**6** If the slack is not accessible, special coloured shims will be inserted in the factory

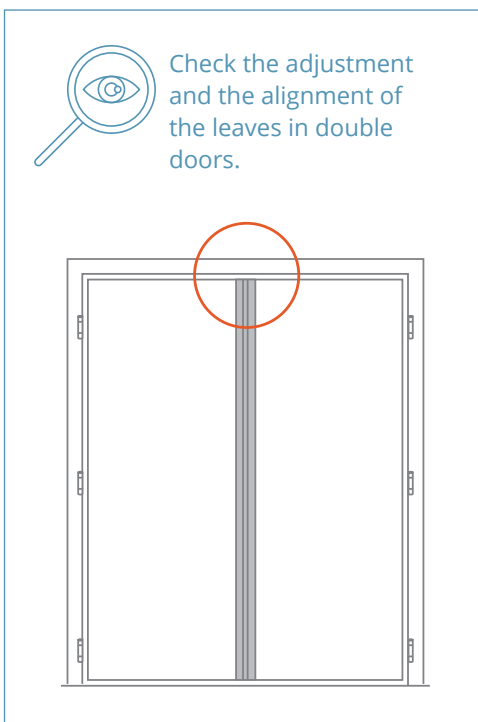
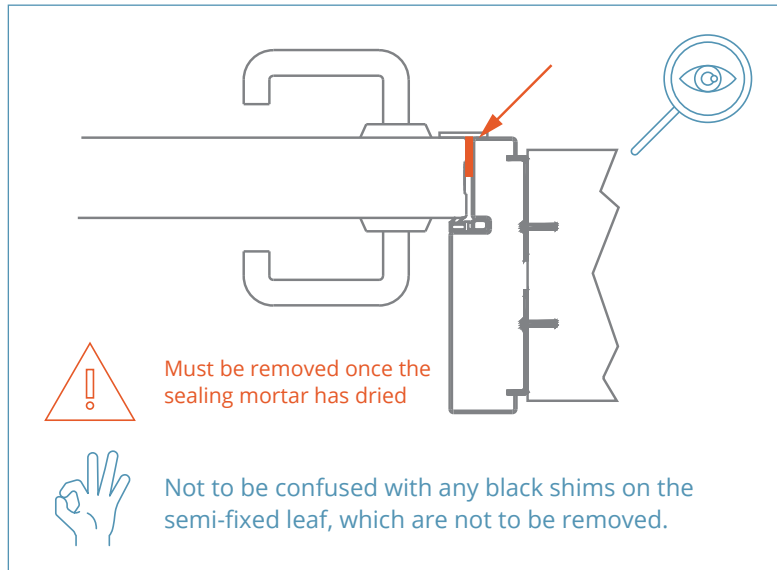
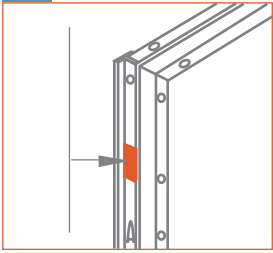

Take care to protect any flammable elements when welding the clamps.

**7** Permanently weld all fitting clamps

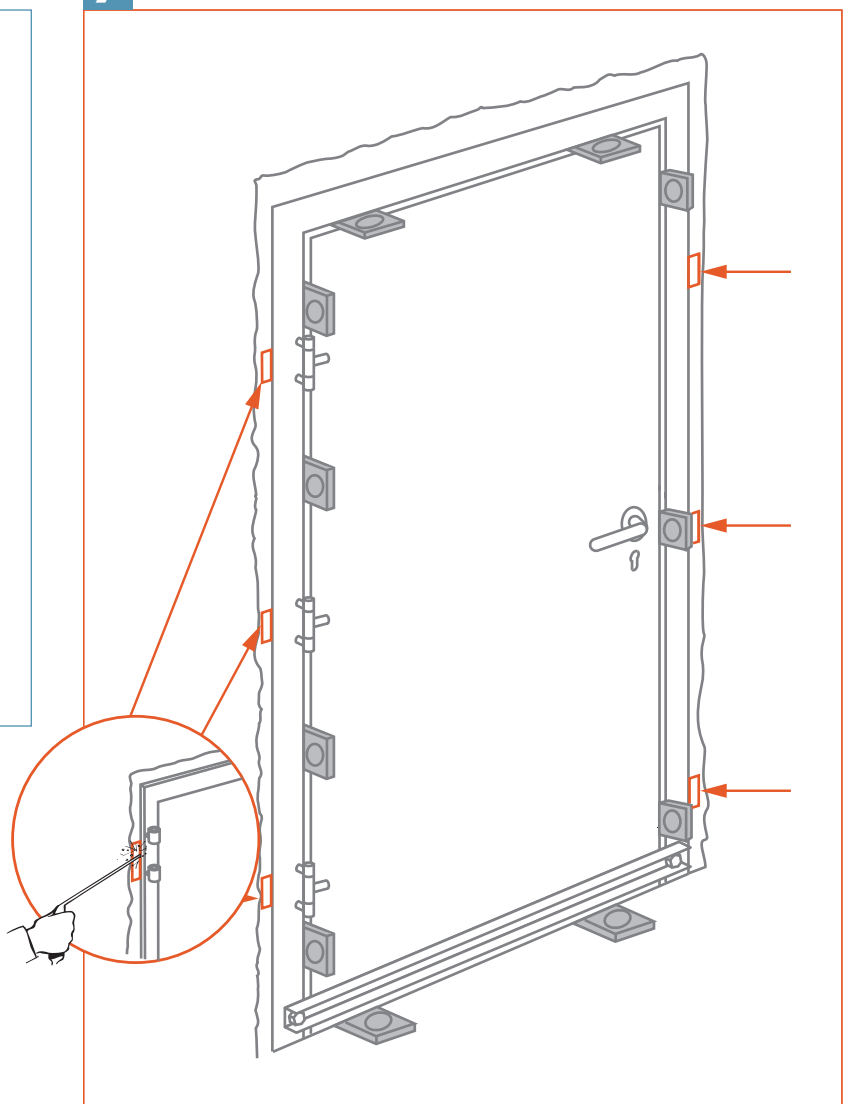

## APPLYING THE SEALING MORTAR

### 1a Single door

Door closed (x = shims).

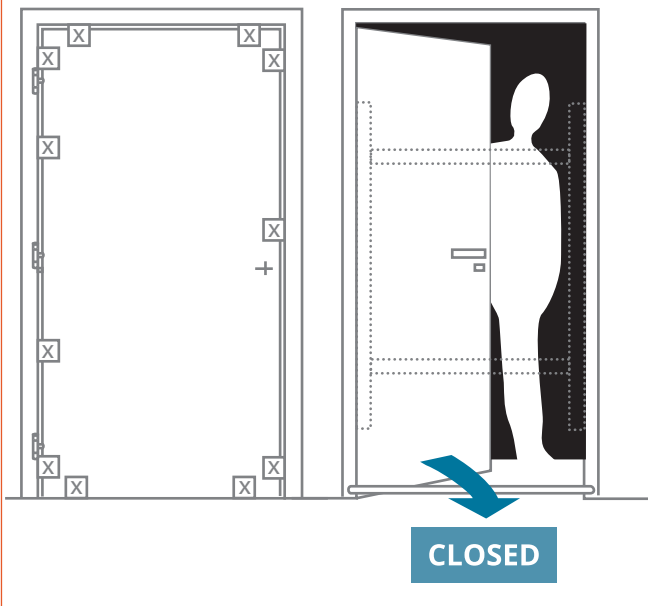

! Door required to remain open.



### 1b Double door

Door closed (x = shims).

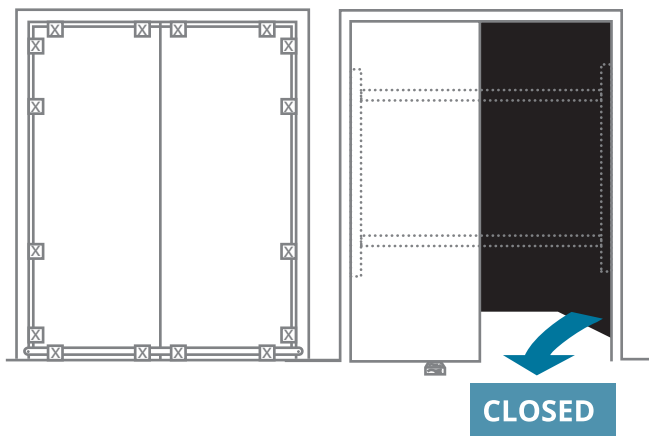

! Door required to remain open.

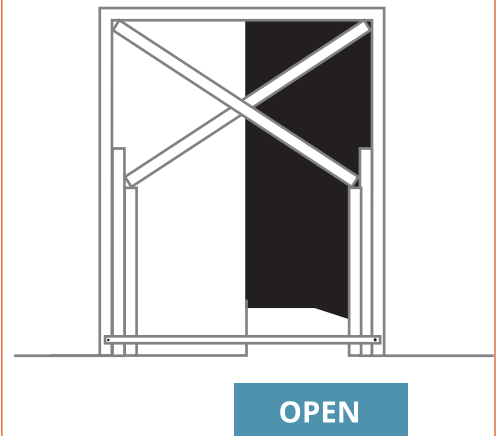

- Under no circumstances should the spacer bars at the bottom of the frame be removed.
- Always leave the shims long enough.
- Prop up where necessary to prevent the frame from bulging (essential when applying with the door open).
- The utmost care must be taken when propping up the frame.

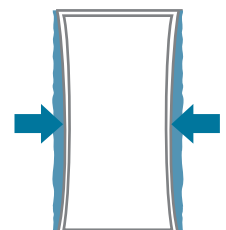

**2** Caulk both sides if necessary

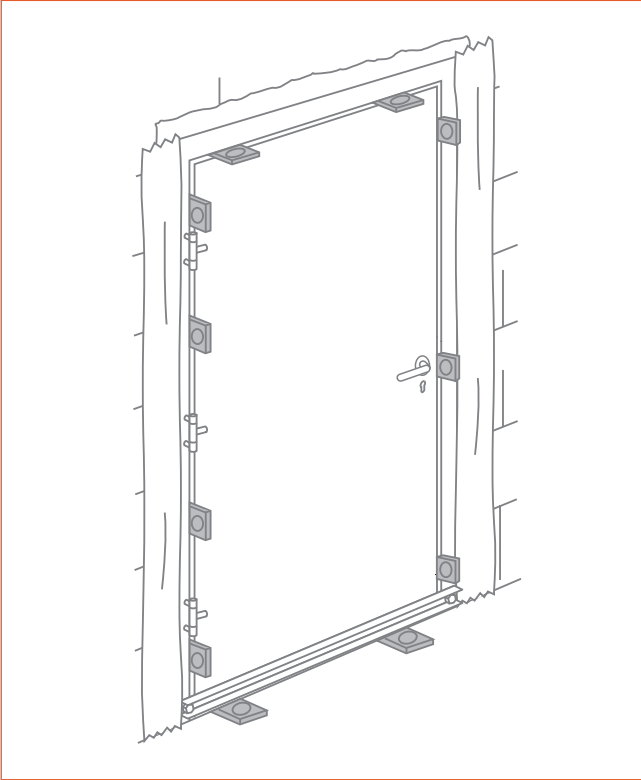

**3a** Injecting the mortar manually

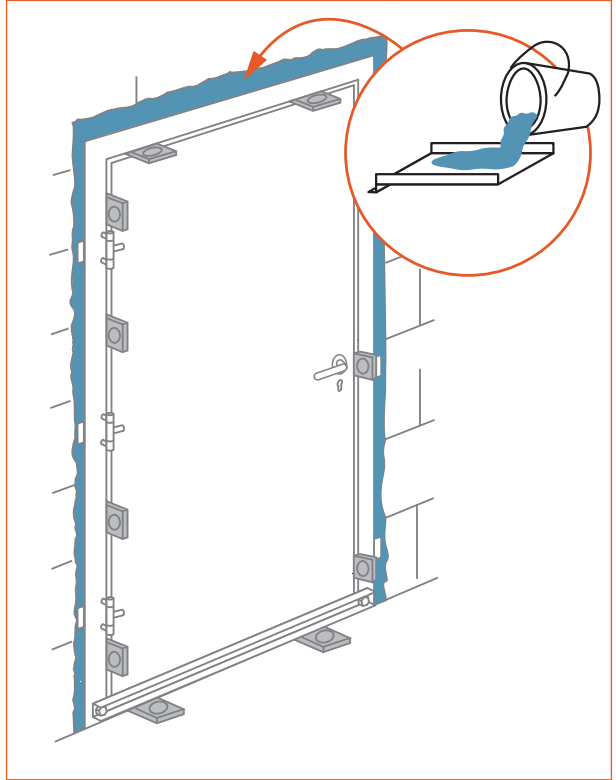

**3b** Injecting the mortar using a concrete pump

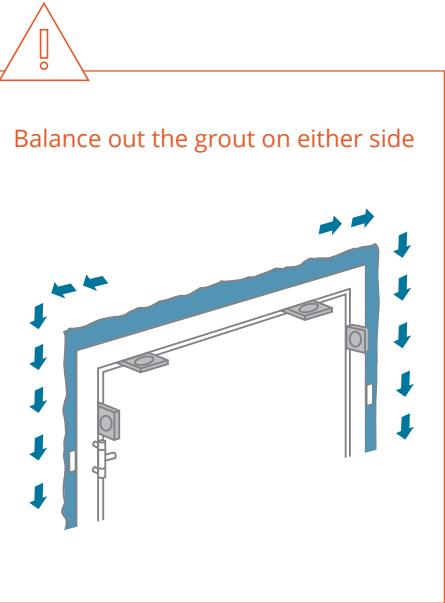
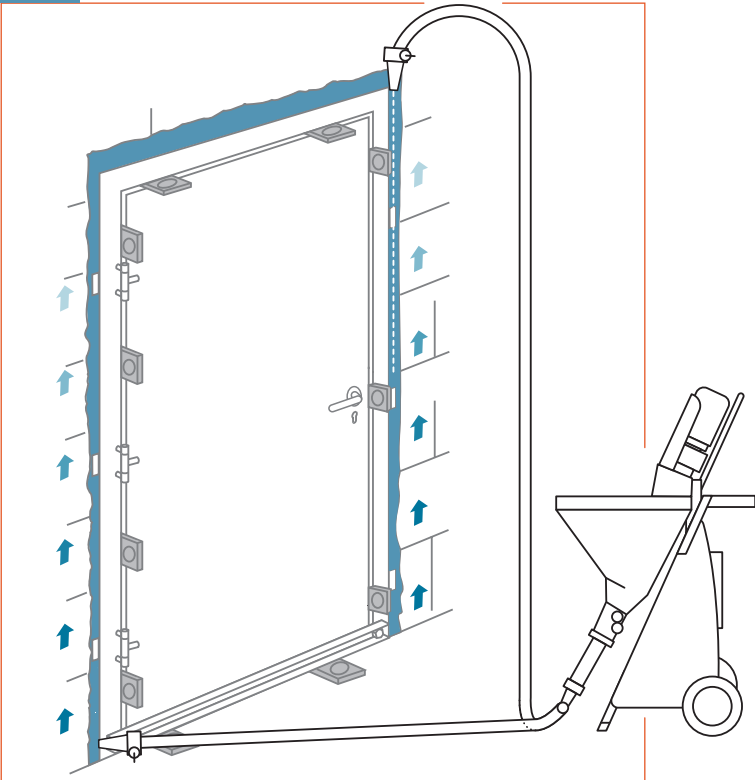

4

Tap the frame (using a rubber hammer) to ensure that the mortar is evenly distributed as it is applied.

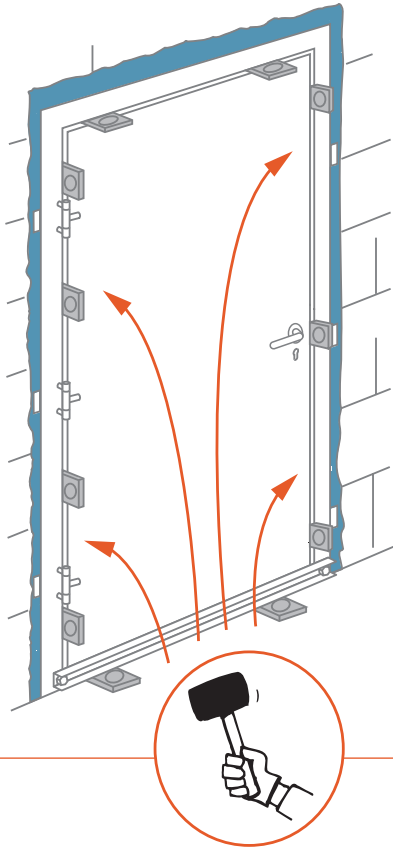

Remove the blue protective film from the leaf and remove any traces of concrete using a damp cloth. This film must be removed immediately after installation.

5

Do not remove the caulking, props, shims or spacer bars until the mortar has set. The time this takes can vary depending on the type of mortar used.

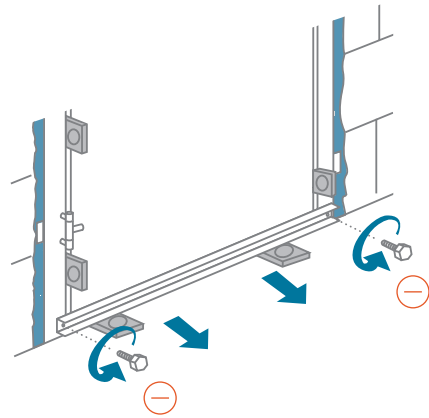

6

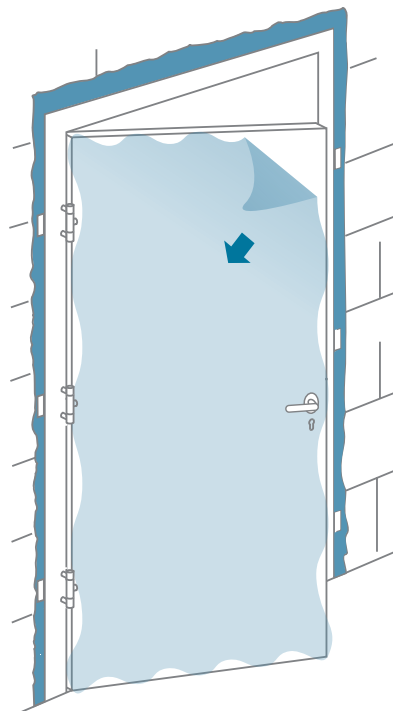

# ADJUSTING THE LEAF ONCE THE MORTAR HAS SET

## HINGES

1

Loosen the screws on the hinge pins and remove the pins.

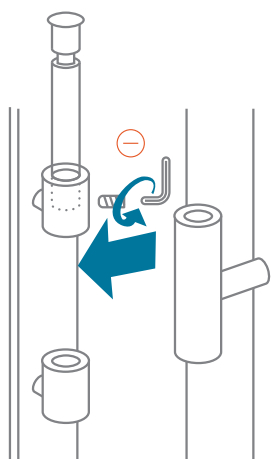

2

Horizontal adjustment

Turn the two corresponding hinge parts of the frame through one and a half turns (in the same direction) for each turn made to adjust the leaf hinge.

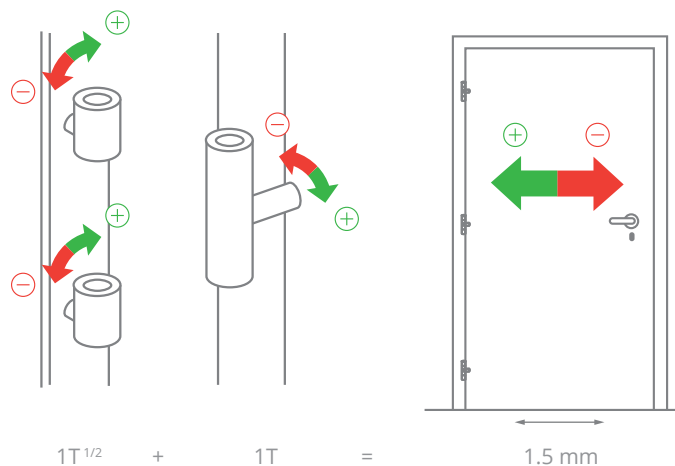

Clockwise: reduces the slack around the hinge.

Anti-clockwise: increases the slack around the hinge.

3

Compression adjustment

Straighten the door by adjusting each hinge individually if necessary.

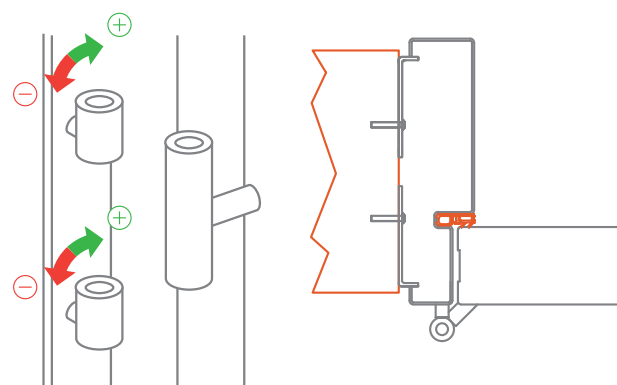
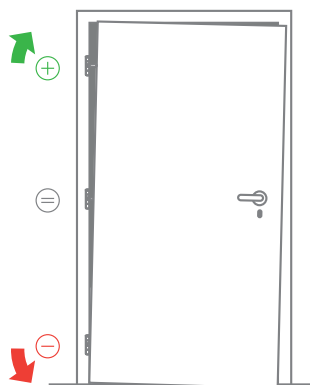

Only adjust the hinge parts of the frame. The compression of the lock surround can be adjusted using the striker plates (see chapter on striker plate adjustment).

The pins must engage easily.

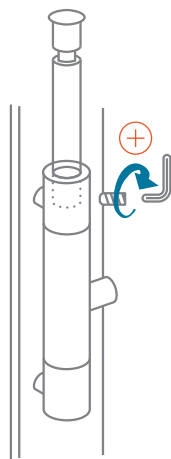
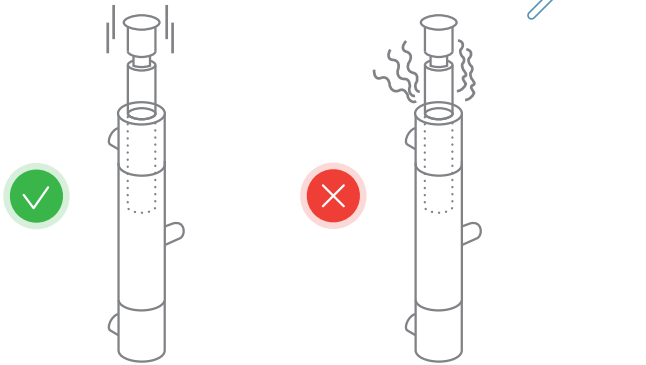

Make sure that all hinge pin screws have been firmly tightened.

Tip and tip.  
Business card test.

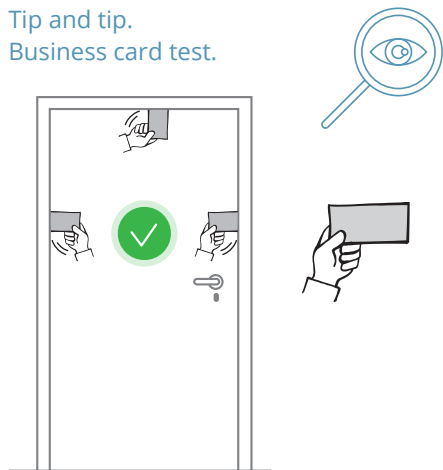

The business card should stick slightly.  
Not a contractual requirement.

## STRIKER PLATES

### SINGLE DOOR

File down the rounded parts if more slack is required for the bolt and check that the bolt is fully engaged.

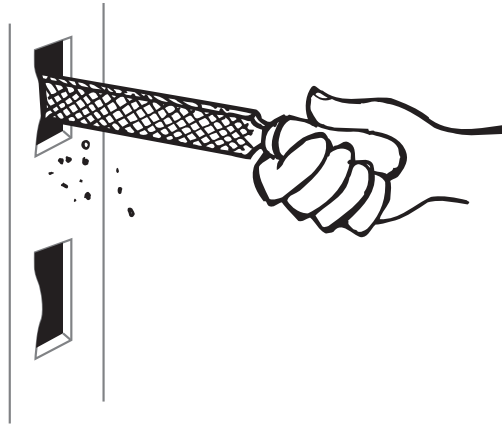

### DOUBLE DOOR

Semi-fixed leaf side.  
Adjust to compress the rebate joints along the full height.

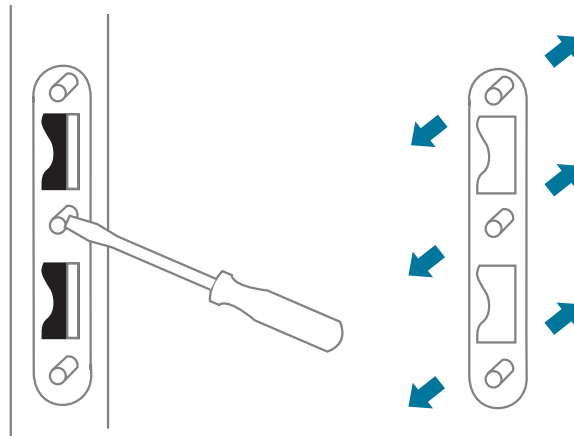

### ADJUST IF THERE IS AN ADJUSTING SCREW

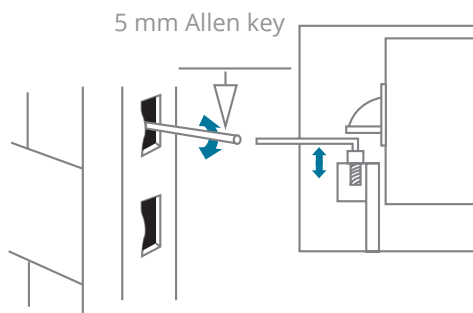

### Business card test

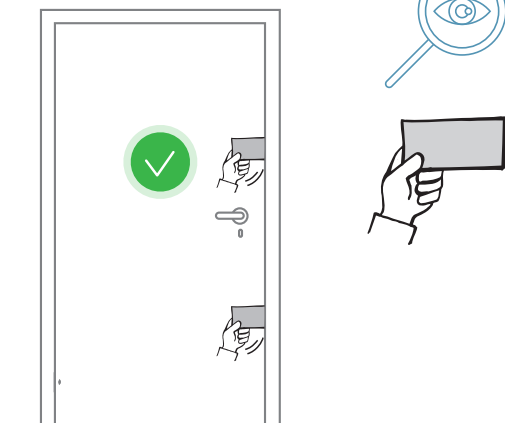

The business card should stick slightly.

## RODS

### For bolts and 3-point locks

#### 1 Mark on the floor

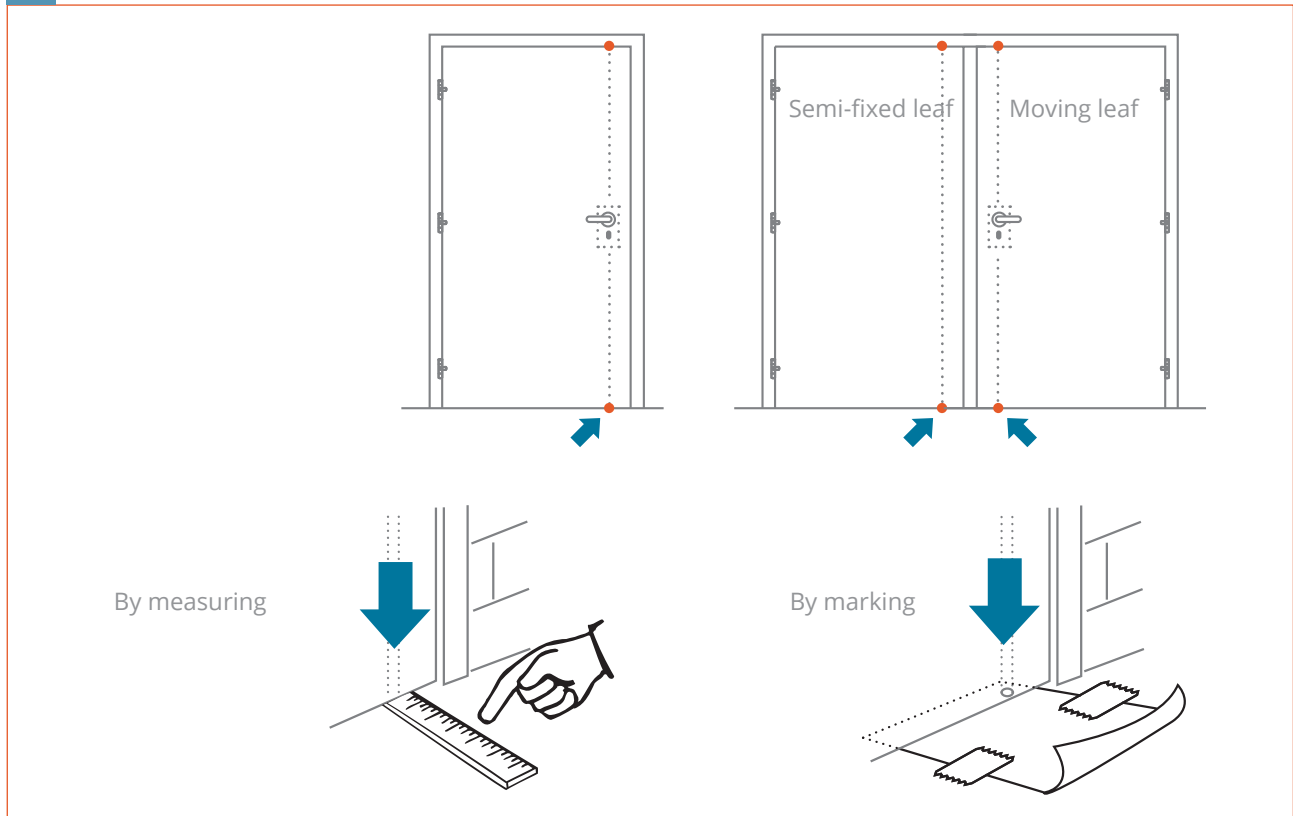

#### 2 Drill

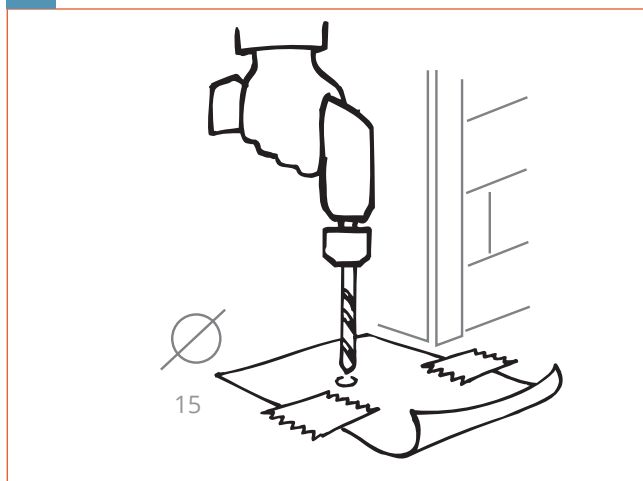

#### 3 Attach the finger-plate

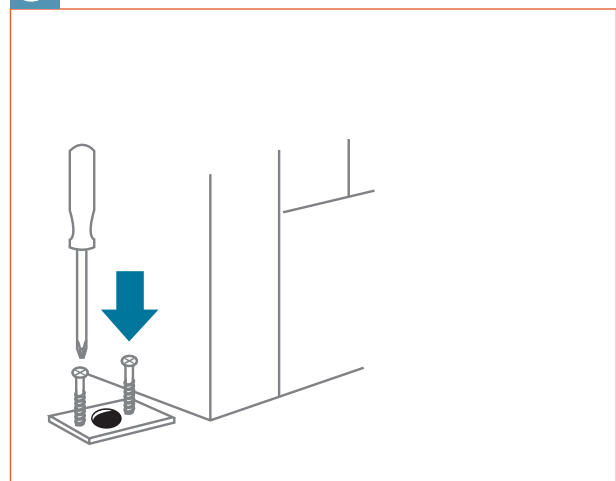

For automatic bolts on double doors:

the moving leaf can only be closed again once the housing hole has been drilled into the ground.

Ensure the following:

- that the rod does not rub against the striker plates; if it does, adjust it accordingly;
- that the automatic bolt is sufficiently sunken to ensure that the rods protrude by +/-15 mm, or else bring the leaves closer together by adjusting the hinges horizontally or raising the friction plate.

# GROUND SOCKET

Easy clean



Ball-based

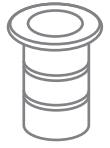

## 1 Mark on the floor

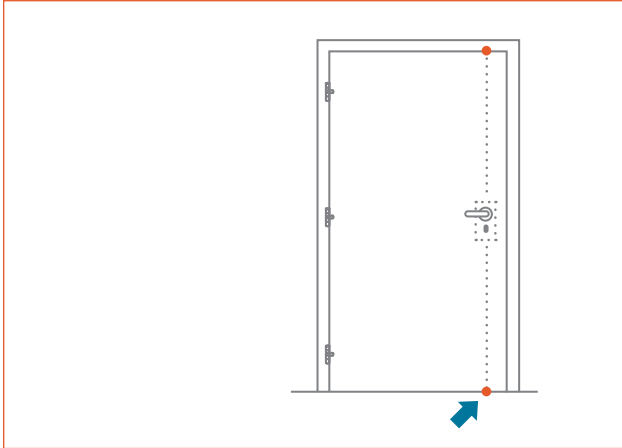

## 2 Drill

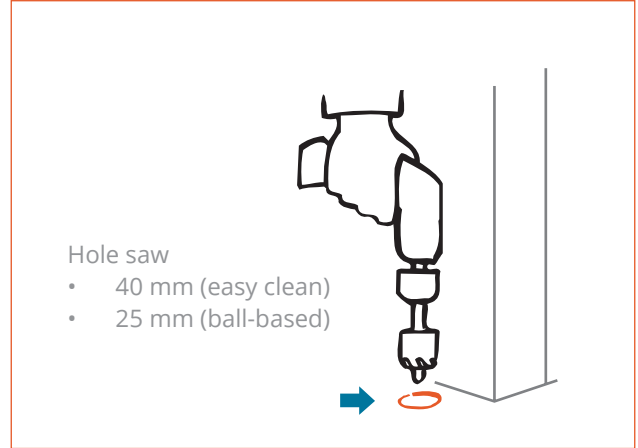

## 3 Seal

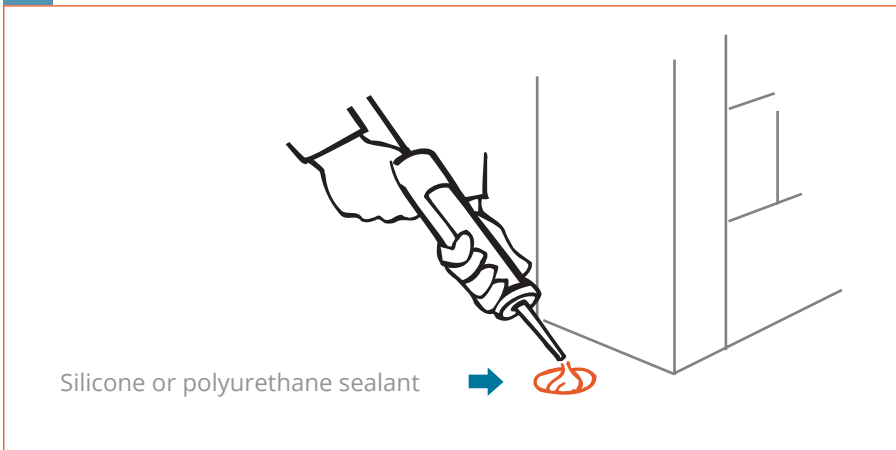

## 4 Sink

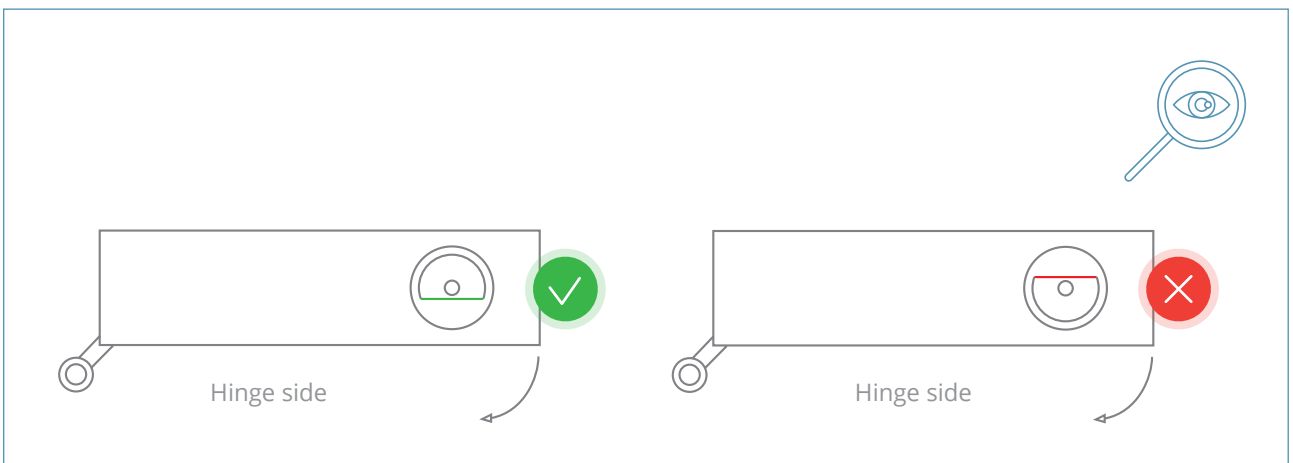
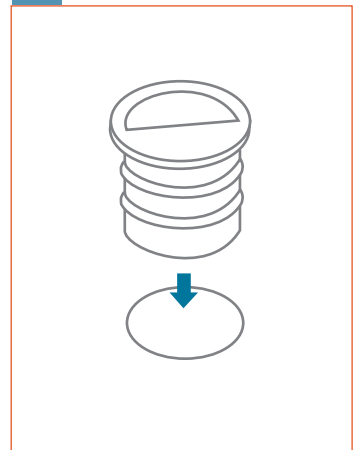

# FITTINGS INSTALLATION

## CYLINDER

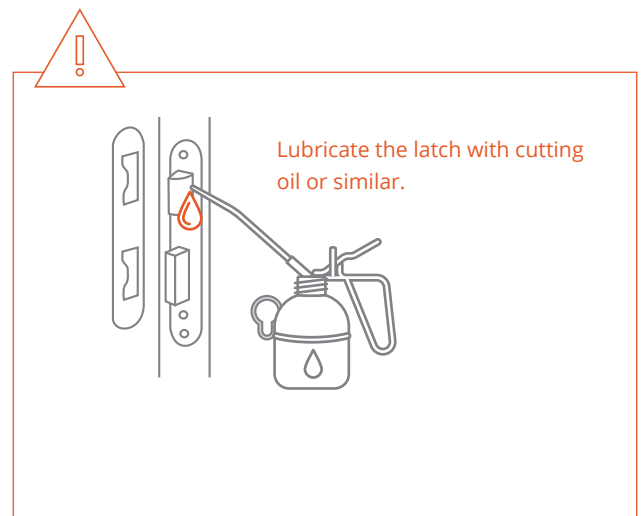
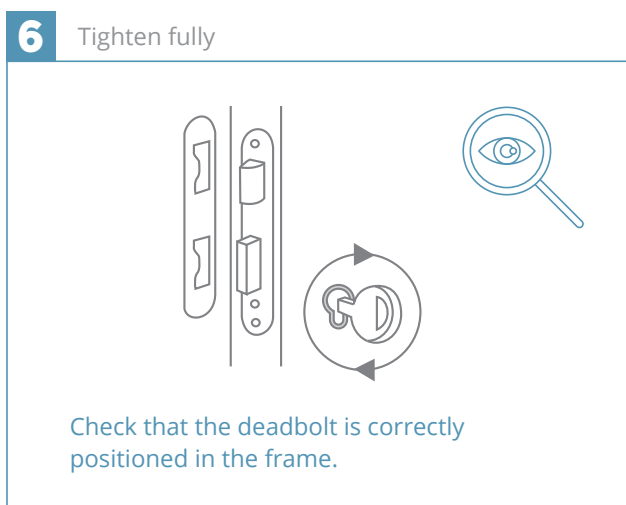
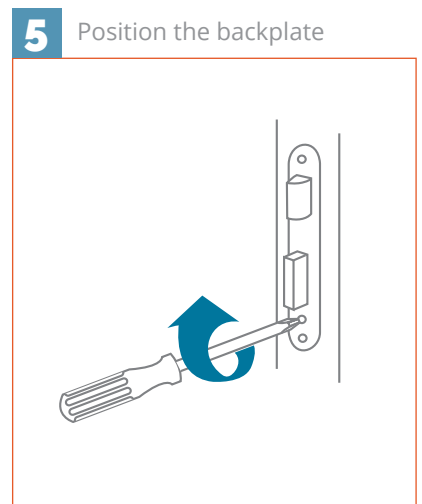
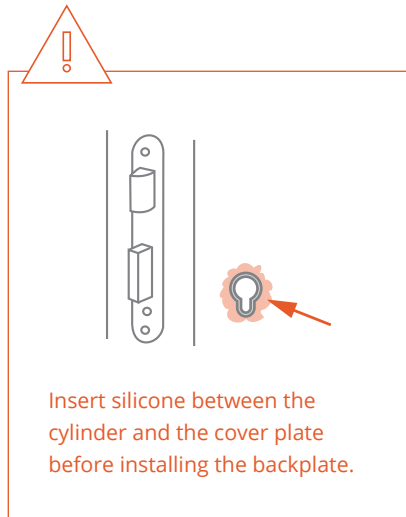
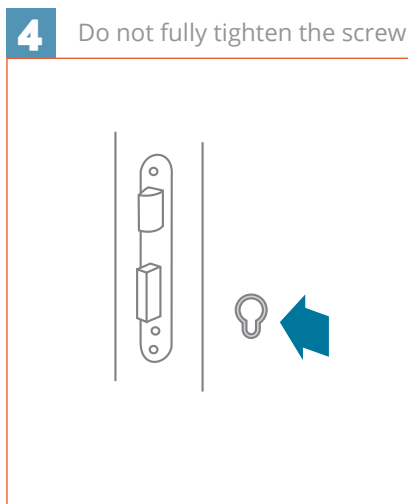
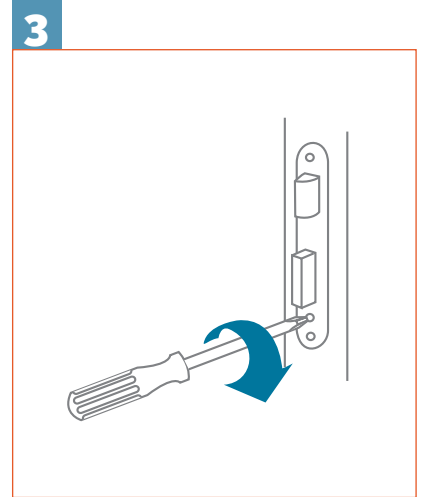
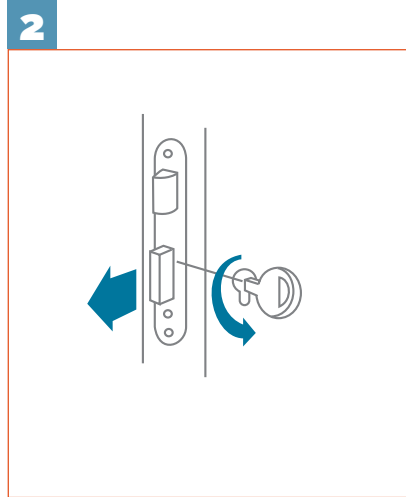
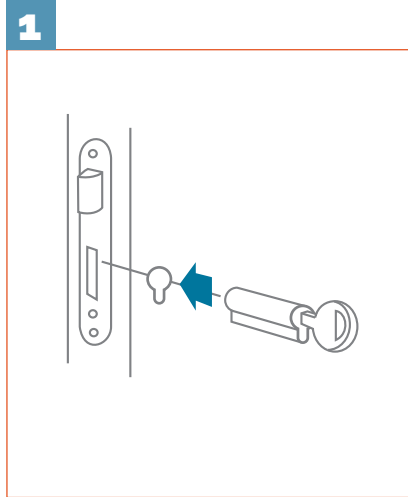

# HANDLES

## ASSEMBLY

**1** Secure by tightening the through screws firmly

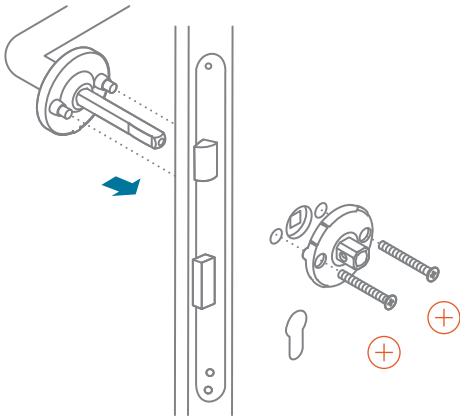

**2** Clip on the backplate

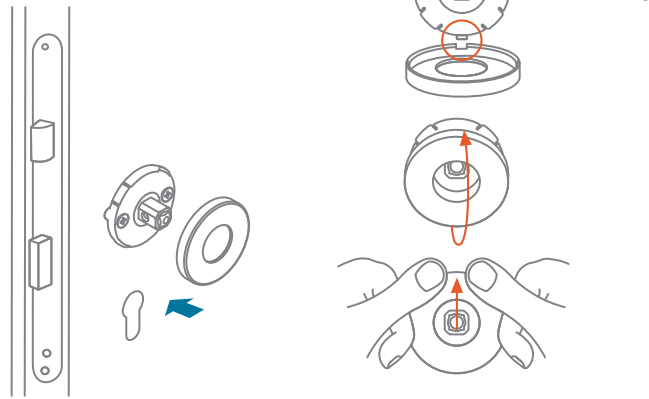

**3** Insert the handle profile

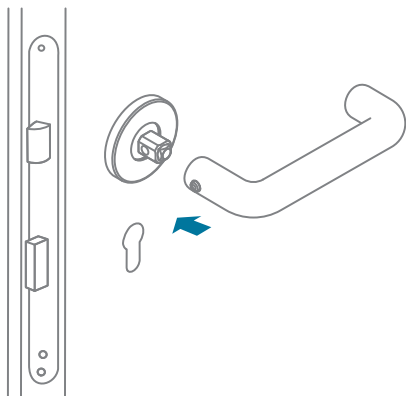

**4** Tighten the set screws firmly

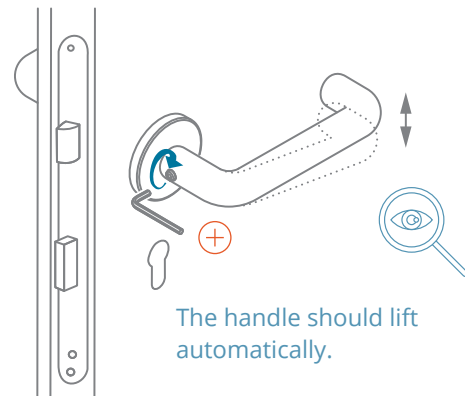

## DISASSEMBLY

**1** Loosen the set screws

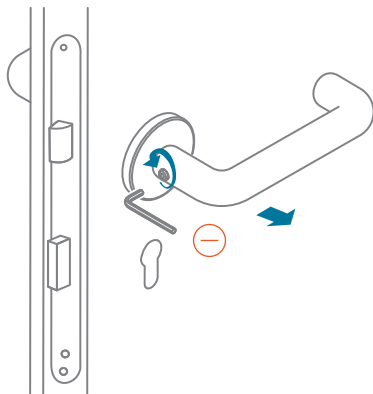

**2** Unclip the backplates using a removal key

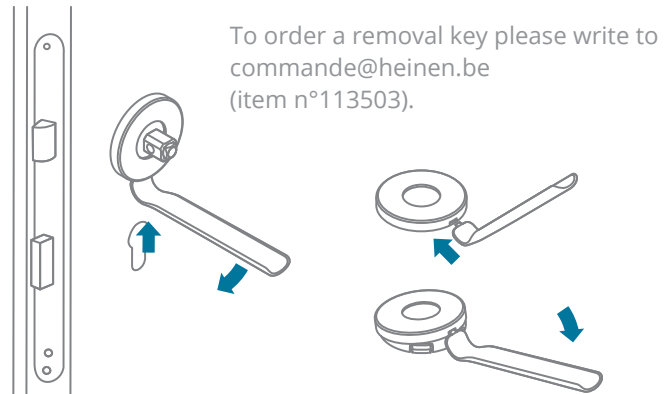

## ANTI-PANIC BAR

### 1 Attach the spacers

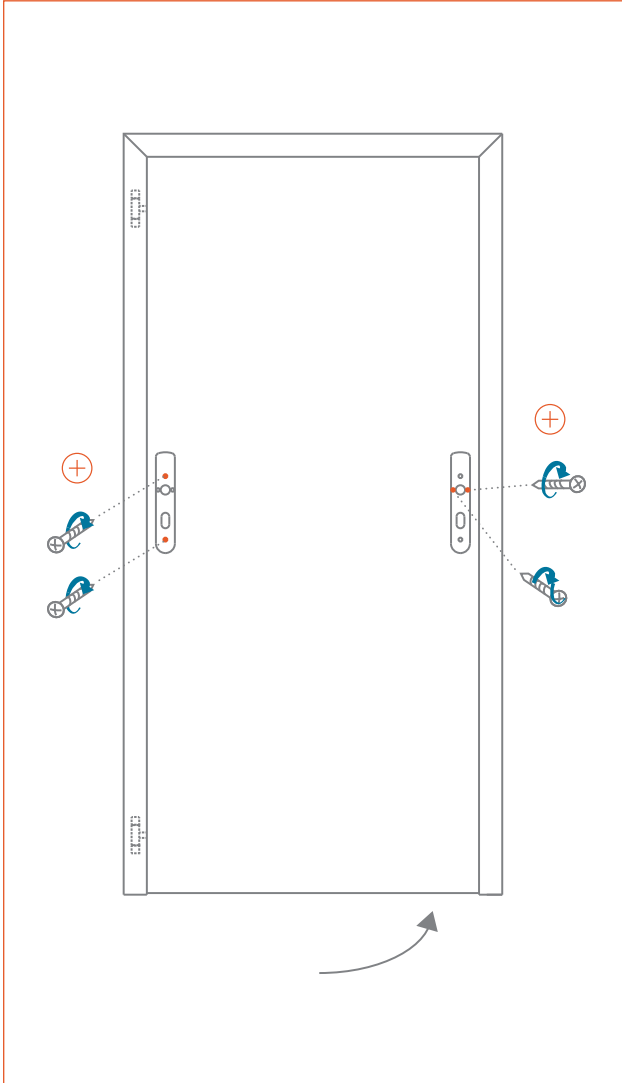

### 2

Install the panic bar on the spacers in accordance with the supporting documentation for the panic bar.

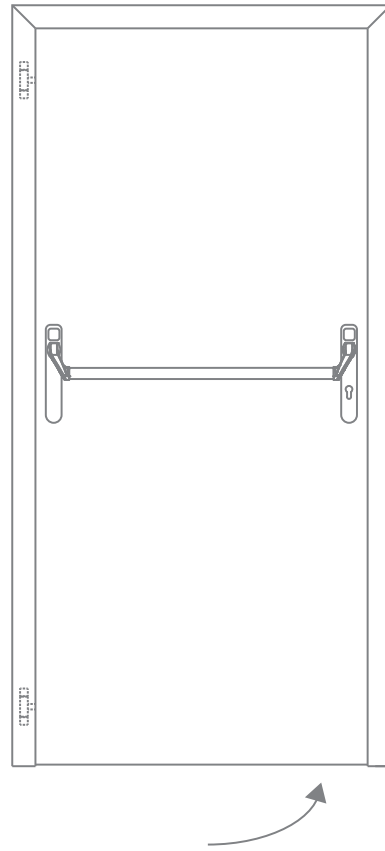

## DOOR CLOSER

### 1 Check that it functions just as it should and that the leaf is balanced.

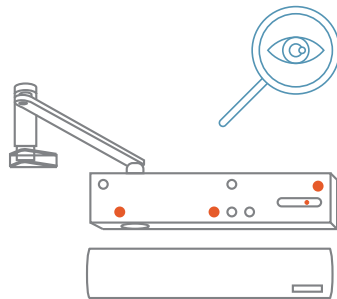

### ADJUST AS REQUIRED

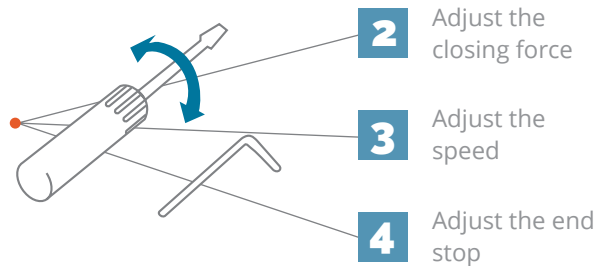

Refer to the supporting documentation for the installed door closer.

## CLOSURE SELECTOR

- 1 The semi-fixed leaf must close before the moving leaf

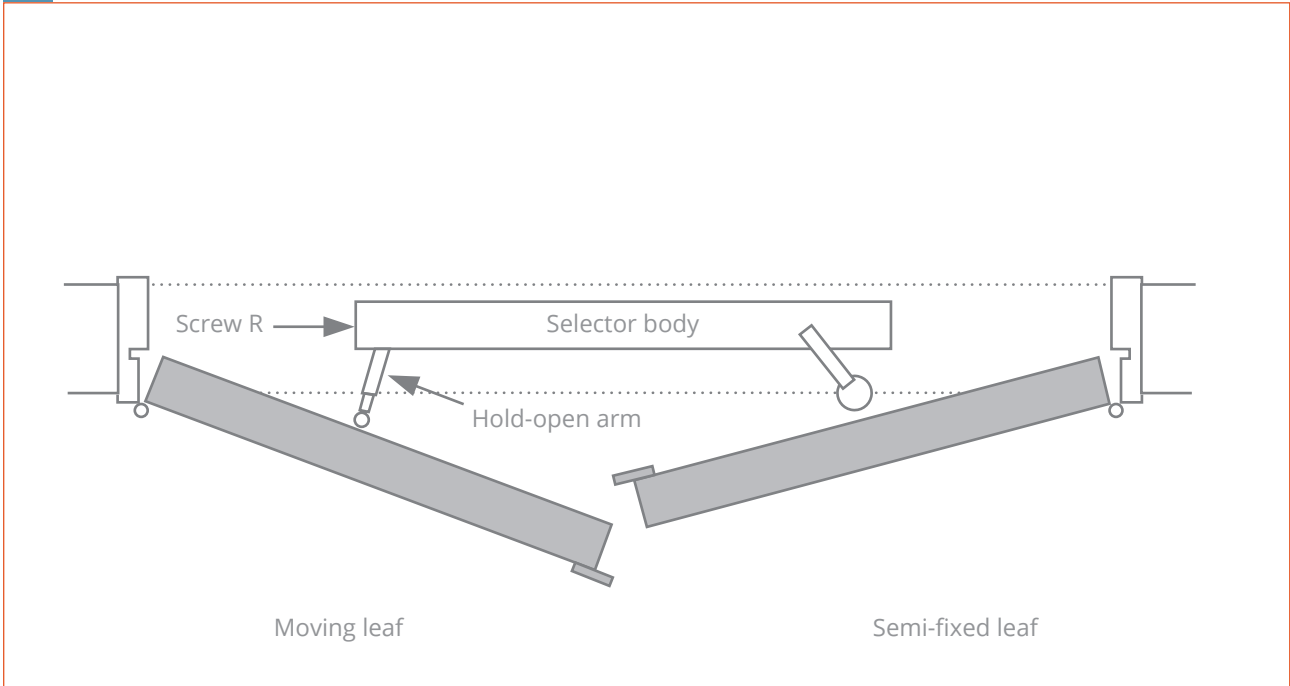

- 2 Check that the hold-open arm is perpendicular to the moving leaf

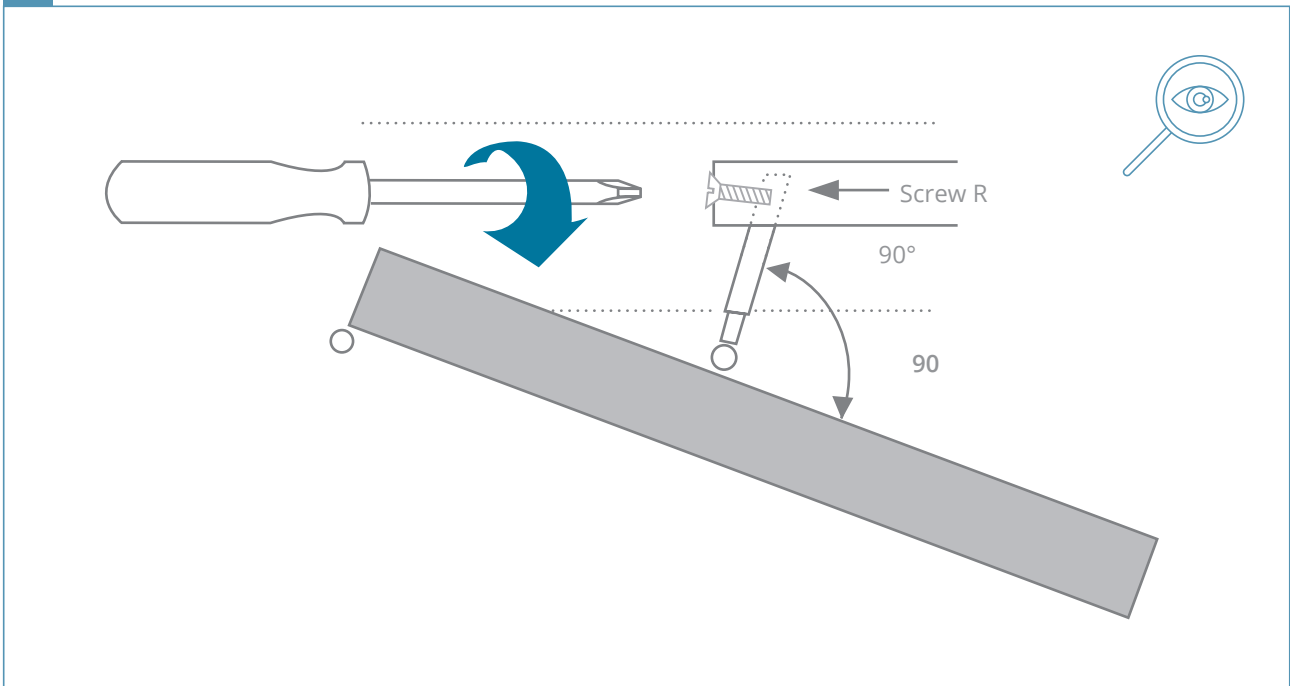

## FINAL CHECK AND FINISHING



- Check that the screws are tightly fastened.
- Clean with a damp cloth.
- Do not clean with water or a pressure washer.



Use a Loctite 243-type threadlocker for the handle screws.



### 1. GENERAL TERMS

Unless otherwise stated, the 15-year warranty applies to all Heinen Metal + door blocks installed with the installation clamps and mortar filling. A 10 year guarantee applies to all door blocks installed by screwing, without concrete filling. The guarantee covers the mechanical stability of the door block and the seals. For glazing, hardware and other equipment, the warranty is limited to one year unless otherwise specified by the manufacturer.

### 2. CONDITIONS

#### **The warranty is subject to:**

1. the respect of the installation instructions as described in the appropriate Heinen installation manual;
2. use of the product in the context of normal use;
3. a clearly legible serial number (only valid for doors produced after Sept. 2016);
4. storage and assembly protected from the weather and in a dry environment;
5. the absence of any mention limiting or cancelling this warranty in the price offer or order confirmation.

### 3. EXCLUSIONS

#### **Damage related to:**

- an accident, abnormal use or caused by forced entry and/or vandalism;
- using harsh products (caustic cleaning products, road salt, etc.);
- corrosion or exposure to extreme weather conditions (flooding, storms, etc.);
- using a large quantity of water or using a high-pressure cleaner.

#### **The warranty will be cancelled:**

- if the door set has been fitted with locks, accessories or other fittings which have not been supplied by Heinen or have been imposed by the customer and not approved by Heinen;
- if the door set is modified and/or has fittings from a third party;
- if malfunctions occur linked to fitting the door set and/or hardware incorrectly.

### 4. LIABILITY LIMIT

If the Customer has suffered damage as a result of defects in the goods supplied by HEINEN DOORS BELGIUM, incorrect deliveries and/or deviations in quantities, the liability of HEINEN DOORS BELGIUM, without prejudice to what is stipulated in Article 10 of the General Terms and Conditions of Sale, is limited to the replacement of the missing or defective parts or the payment of the equivalent value of the price of the goods delivered, regardless of the amount of the damage suffered. In no event shall HEINEN DOORS BELGIUM be liable for indirect, incidental or consequential damages, such as, but not limited to, loss of business, loss of profits, additional costs, loss of turnover.

Heinen reserves the right to replace defective parts by parts with a slightly different design.





[www.heinen-doors.com](http://www.heinen-doors.com)