



mediclinics

REDEFINING
PUBLIC WASHROOMS



PUBLIC WASHROOMS THAT ARE TRANSFORMED INTO UNIQUE SPACES

At **Mediclinics**, we believe every detail in design counts. We expertly blend functionality, design, and user experience in every product, transforming public washrooms into sophisticated and memorable spaces. From cutting-edge hand dryers to modern, safe changing stations, our products are manufactured with high-quality materials and rigorously tested to meet

the highest certification standards. This guarantees durability, efficiency, and easy maintenance, making them ideal for demanding projects. With over 50 years of experience, **Mediclinics** is the perfect partner for those seeking innovative, elegant, and functional solutions that set trends and turn spaces into true works of style.

01

HAND
DRYERS
P. 06

02

WASH
AND DRY
STATIONS
P. 24

03

BEHIND THE
MIRROR
SOLUTIONS
P. 34

04

BABY
CHANGING
STATIONS
P. 46

05

SOAP
DISPENSERS
P. 56

06

TOILET PAPER
DISPENSERS
P. 62

07

PAPER TOWEL
DISPENSERS
P. 68

08

BINS
P. 74

09

BATHROOM
ACCESSORIES
P. 84

10

PVD FINISH
P. 102

01

All our hand dryers are certified to guarantee efficient and reliable operation during their lifetime. Our range includes fast, hygienic and silent drying models, ideal for both high traffic washrooms and exclusive spaces.

They ensure optimal **HYGIENE** through a **HEPA media filter that retains viruses, bacteria and contaminating particles**, while **ION HYGIENIC®** technology improves air quality. In addition, the use of **BIOCOTE®** inhibits the growth of microorganisms on the surface.

Mediclinics' hand dryers are **energy-efficient** and provide quick drying with minimal environmental impact, therefore becoming an **ECO-FRIENDLY** solution for all settings.

They help generate **SAVINGS** with each use, offering **lower operational costs** compared to both paper towels and traditional dryers, ensuring reduced waste and enhanced efficiency.

HAND DRYERS

01

U-flow®

Designed for those who **value total freedom of movement and hygiene**, this unique hand dryer combines cutting-edge aesthetics with innovative functionality.

Its unique shape ensures a drying experience that not only guarantees hygiene and comfort, but also an incomparable **feeling of well-being**.

The perfect solution for high-traffic washrooms. Ideal for spaces where design, energy efficiency and state-of-the-art technology are essential.



Freedom of movement,
design and innovation



U-flow®

- Low energy consumption.
- Ultra-fast drying.
- HEPA media filter for better air quality.
- BIOCOTE® antibacterial protection on surface.
- ION HYGIENIC® technology for enhanced air purification.
- PLUG IN system for immediate replacement of the hand dryer.
- Removable water tank.
- Direct connection to main wastewater outlet.



WHITE



TOTAL BLACK



BLACK



SATIN

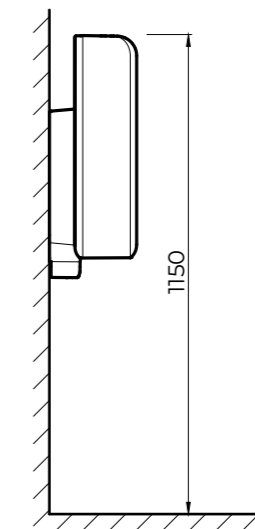
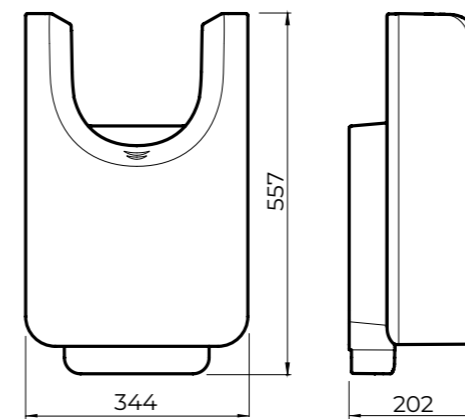

All measurements in the catalogue are indicated in mm



01

dualflow[®] plus

Highly-efficient hand dryer with an avant-garde design, it is ideal for the most demanding settings. **Its innovative technology redefines the drying process**, guaranteeing maximum hygiene, safety and performance in every use.

This hand dryer provides an ultra-fast drying thanks to its state-of-the-art brushless motor, also ensuring low maintenance and an outstanding durability.

It is the ideal choice for those looking for high performance and long-term reliability, without renouncing to style and sophistication.



State-of-the-art
drying



dualflow[®] plus

- Low energy consumption.
- Ultra-fast drying.
- Brushless motor, which does not require maintenance.
- HEPA media filter for better air quality.
- BIOCOTE[®] antibacterial protection on surface.
- Low sound level in its category.
- Removable water tank.
- Optional: Direct connection to main wastewater outlet.
- Optional: ION HYGIENIC[®] technology for air purification.



WHITE



BLACK



SATIN

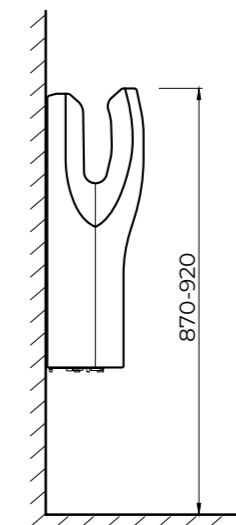
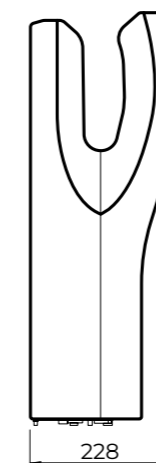
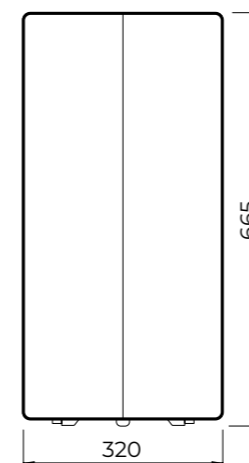

01

machflow[®] plus

Energy-efficient hand dryer, designed for high-traffic areas that require **robust and reliable** equipment.

Equipped with a **high-tech brushless motor**, it ensures exceptional durability and provides efficient drying with lower energy consumption.

With a compact and sturdy design, this hand dryer stands out for its innovative PLUG IN system, which simplifies maintenance and ensures **uninterrupted operation 24/7**.

Perfect for demanding spaces that require **powerful and durable equipment**.



Energy efficiency for
high-traffic washrooms



machflow[®] plus

- Low energy consumption.
- Ultra-fast drying.
- Brushless motor, which does not require maintenance.
- PLUG IN system for immediate dryer replacement.
- HEPA media filter for better air quality.
- Low sound level in its category.
- Optional: ION HYGIENIC[®] technology for air purification.



WHITE



BLACK



SATIN



BRIGHT



PVD COATING

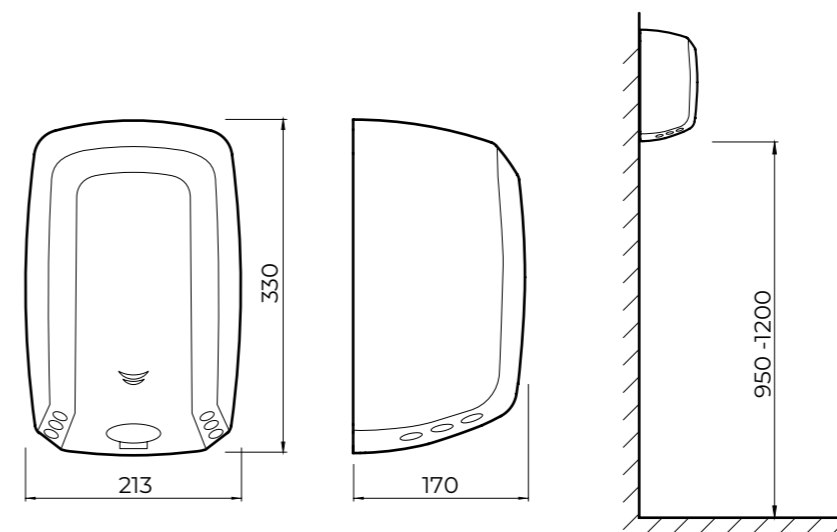

01

speedflow[®] plus

High-speed hand dryer with elegant design. Its ultra-slim shape makes it the perfect solution for washrooms that need to **meet ADAAG accessibility standards**.

With its ultra-efficient energy consumption and **minimalist design**, it is ideal for high-traffic areas while also fitting seamlessly into elegant and exclusive settings.



High performance
for compact spaces



speedflow[®] plus

- ADDAG accessibility standards compliant.
- Low energy consumption.
- Fast drying.
- HEPA filter media for better air quality.
- Low noise level in its category.
- Optional: ION HYGIENIC[®] technology to purify the air.



WHITE



BLACK



SATIN



BRIGHT



PVD COATING

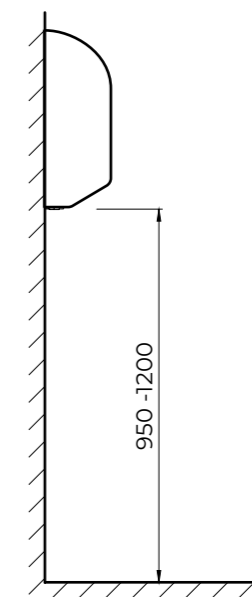
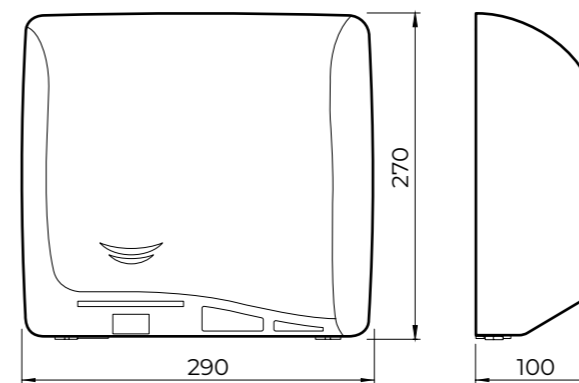

02

All-In-One wash and dry stations are an elegant and unique hand washing and drying system **integrated into the countertop or wall**. It features

a sensor-activated **soap dispenser, water faucet and hand dryer**. Solution designed to avoid unnecessary movement inside the washroom, helping

to **prevent water from spilling** onto the floor. All-In-One allows for efficient space optimization, creating minimalist, functional and safe areas.



WASH AND DRY STATIONS

02

all-in-one

COUNTERTOP

The All-In-One countertop system is elegantly integrated into the sink.

This solution combines water and soap in a single faucet, while a second faucet ensures efficient hand drying, providing a **fast, convenient and splash-free** hygiene process in compact spaces.

All-In-One is perfect for high-traffic areas that prioritize **hygiene, sustainability and exclusivity**.



Technology, design
and efficiency
in the same space



all-in-one

COUNTERTOP

- Stylish, curved swan neck design.
- Automatic water and soap dispensing faucet.
- Hand drying faucet with an advanced MACHFLOW® eco-fast hand dryer.
- Sensors optimize water, soap, and energy savings.



BLACK



BRIGHT

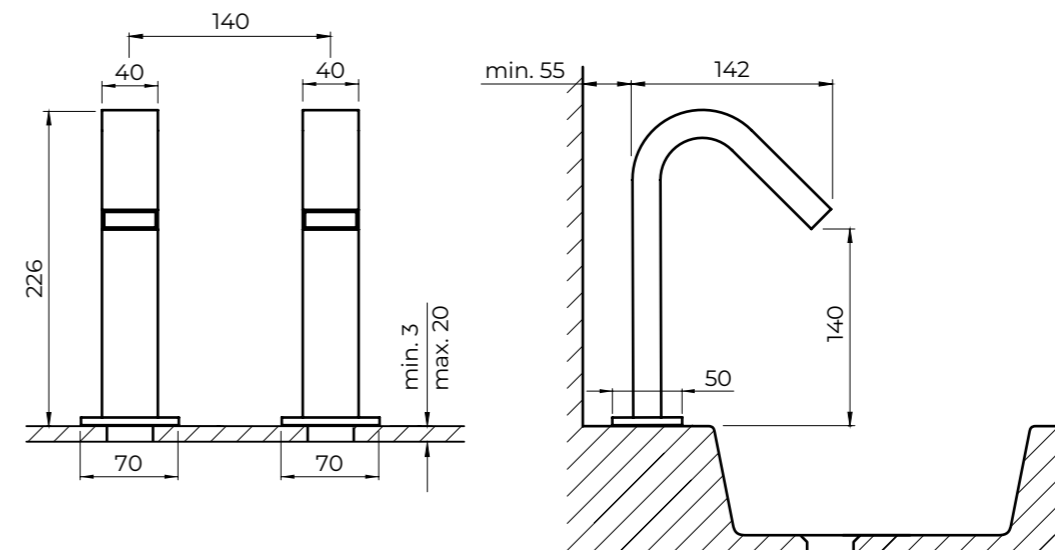

02

all-in-one

WALL

The All-In-One wall-mounted washing and drying system is crafted to seamlessly blend into the washroom's design.

Featuring separate faucets for water, soap, and hand drying, it provides **optimal hygiene without the need for movement.**

Thanks to its **energy efficiency and ultra-fast drying**, All-In-One is the solution that redefines the hand cleaning experience in public washrooms.



Intuitive and user-friendly,
with no need for movement



all-in-one

WALL

- Elegant lines and curves, designed for seamless integration into any space.
- Automatic, adjustable soap and water faucets for enhanced consumption efficiency.
- Hand drying faucet featuring the advanced, eco-fast MACHFLOW® hand dryer.



BLACK



BRIGHT

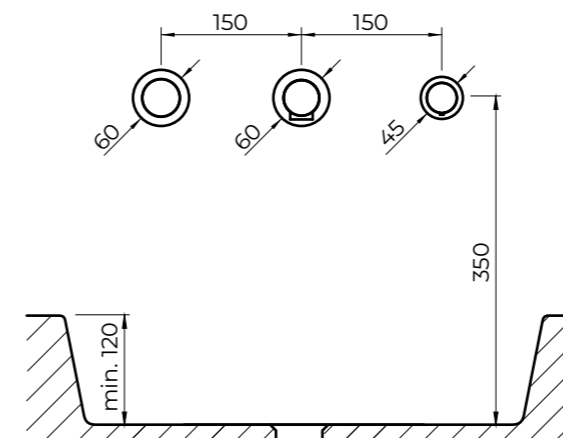
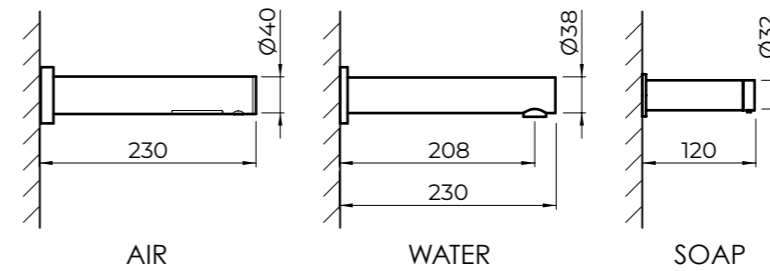

03

Exclusive **hand hygiene system, hidden behind the mirror (BTM)**, maximizes functionality in high-traffic spaces. Its design allows hand washing and drying without the need to move around the washroom.

This innovative system can include a **water faucet, automatic soap dispenser, ultra-flat dryer or paper dispenser**, all designed to provide an intuitive, agile and touch-free cleaning experience.

BTM solutions optimize energy consumption thanks to their sensor-driven operation and the use of an **eco-fast dryer**.



BEHIND THE MIRROR SOLUTIONS

03

BtM

This innovative system is designed to adapt to the architectural and design requirements of each project, providing **versatile solutions** that enable the creation of minimalist, elegant, and highly functional spaces.

It includes a water faucet, automatic soap dispenser, and hand dryer or paper dispenser, all crafted to deliver an **intuitive, quick, and touch-free hygiene experience.**



Solutions that enhance
the architecture



BtM

MODULES: WATER, SOAP AND DRYER

- Complete cabinet with mirror and lock.
- Includes soap, water and drying modules (air or paper).
- Sensor operation for greater savings.
- LED pictograms for intuitive use.
- Adjustable internal mechanisms for better detection of fixed targets.
- Safety mirror.

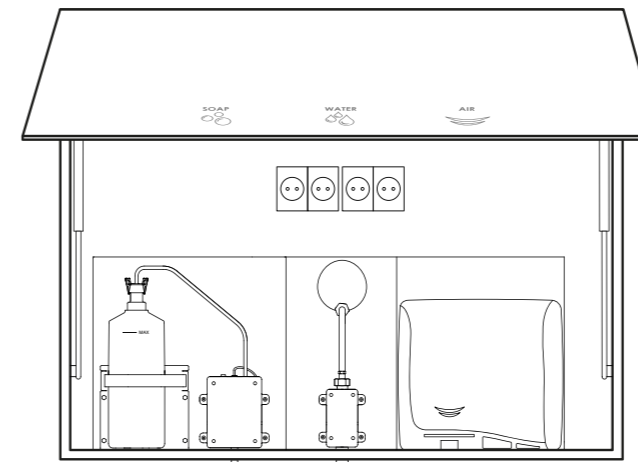

AIR DRYING

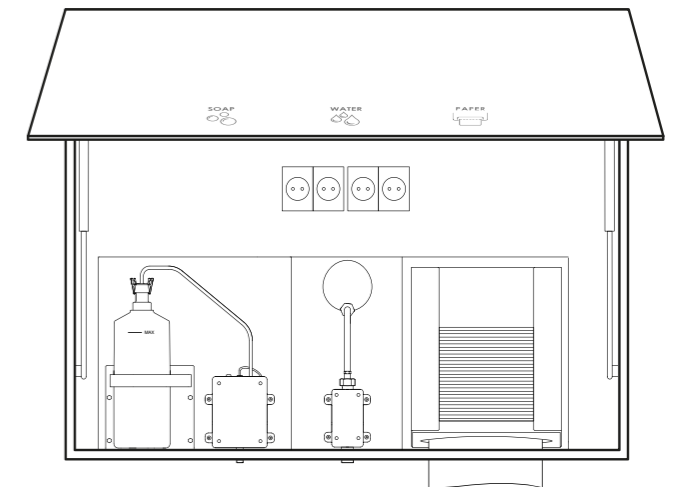

PAPER TOWEL DRYING

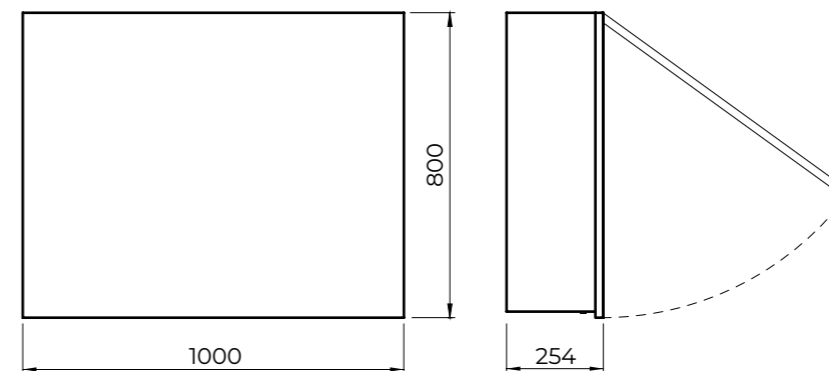

BtM

MODULES: SOAP AND DRYER

- Complete cabinet with mirror and lock.
- Includes soap and drying modules (air or paper).
- Sensor operation for greater resource savings.
- LED pictograms for intuitive use.
- Adjustable internal mechanisms for better detection of fixed targets.
- Safety mirror.

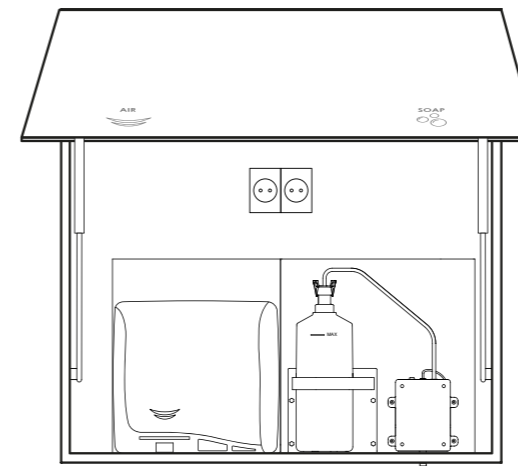

AIR DRYING

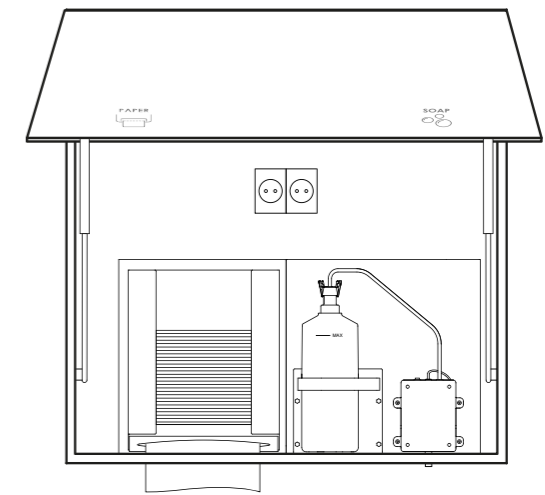

PAPER TOWEL DRYING

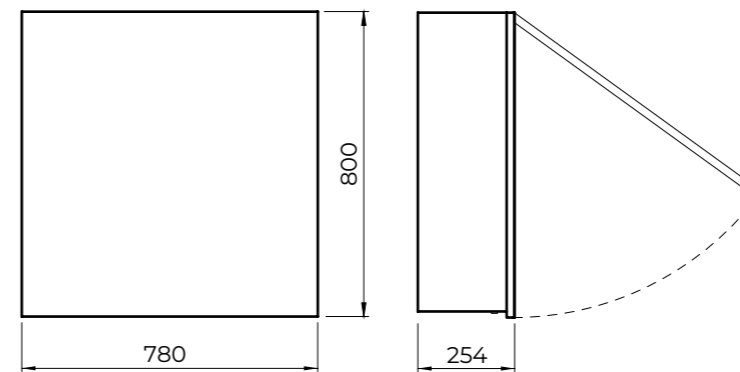



MODULES: WATER, SOAP AND AIR



MODULES: WATER, SOAP AND PAPER TOWEL

BtM

AN INTUITIVE, EFFICIENT, AND TOUCH-FREE HYGIENE EXPERIENCE.

DESIGN



Exclusive user experience

TOUCH FREE

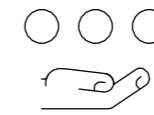

Operated by infrared sensor

LIGHTING



Backlit icons

SAVINGS

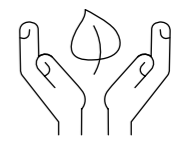

Reduces water and energy consumption

COMBINATION UNIT

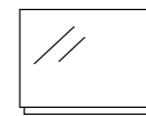

Cabinet with mirror and built-in LED lighting

STRENGTH



Break-resistant mirror

SIMPLICITY

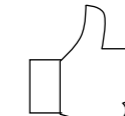

Straightforward installation

MAINTENANCE



Easy access to refill

MODULAR

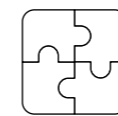

Internal modules can be obtained separately

ADJUSTABLE



Modules with customizable orientation

ADAPTABLE



Adjustable sensors

SAFETY



Safety lock

BtM

DESIGN YOUR OWN CABINET AND INCLUDE THE MOST ADEQUATE SOLUTION FOR THE WASHROOM

WATER

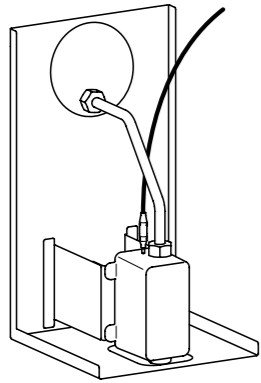

WATER FAUCET

- Automatic non-contact water faucet for hidden installation behind the mirror.
- Activated by infrared sensor ensuring hygiene without physical contact.
- Allows adjustment of the water outlet direction.
- Reduces water consumption.
- Easy installation.

SOAP

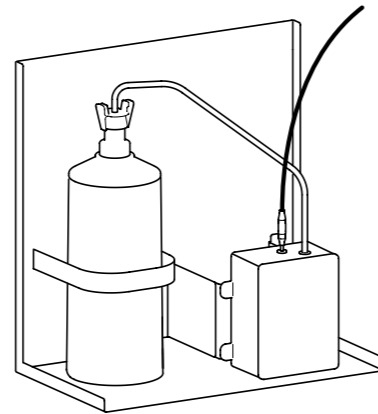

SOAP DISPENSER

- Automatic dispenser with sensor for hidden installation behind the mirror.
- Activated by infrared sensor ensuring hygiene without physical contact.
- Allows the adjustment of the soap outlet direction.
- Soap tank capacity: 1.8 liters. Other sizes possible.
- Energy efficiency: powered by current or optional 4x LR6 batteries.

PAPER

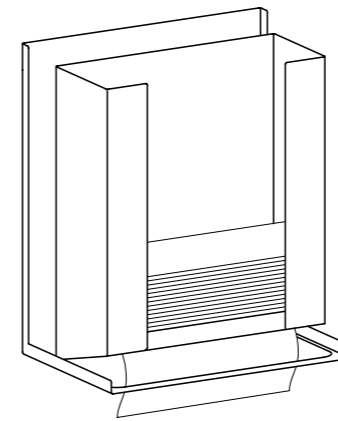

PAPER DISPENSER

- Manual dispenser for folded paper towels, to be installed behind the mirror.
- High quality AISI 304 stainless steel body.
- Holds up to 600 Z-folded or 400 C-folded paper towels.
- Easy to refill.
- Saves space in the washroom.

AIR

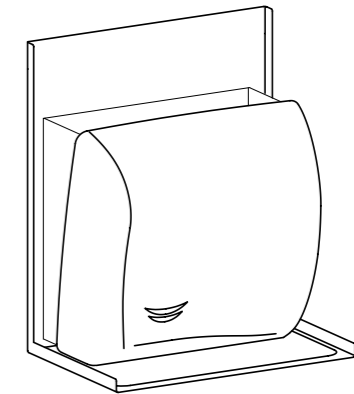

HAND DRYER

- Speedflow® Plus model to be placed behind the mirror.
- High drying speed: 11 seconds with one of the lowest energy consumption in the market.
- Maximum hygiene, incorporates HEPA media filter and optionally an ionizer that purifies the air.
- Activated by infrared sensor that guarantees hygiene without physical contact.
- Automatic safety cut-off to save energy.

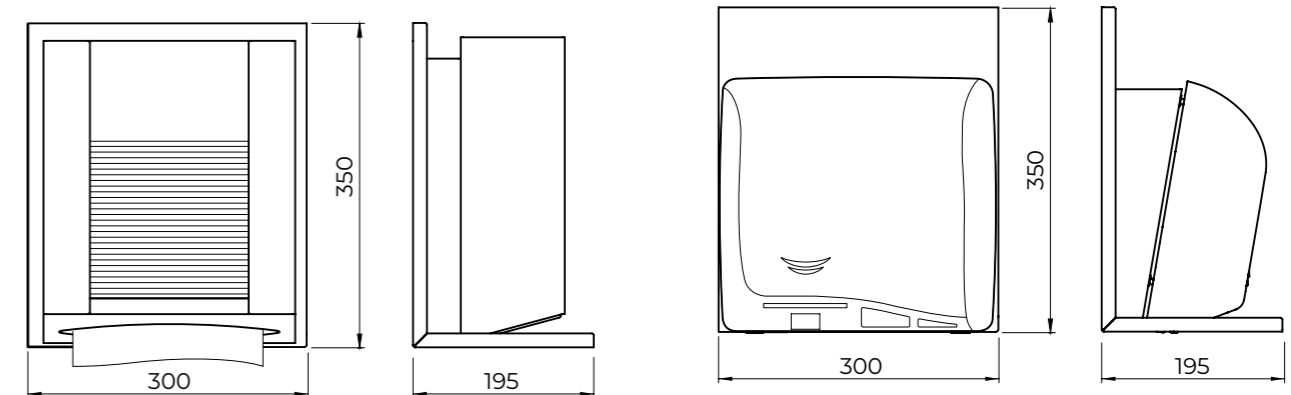
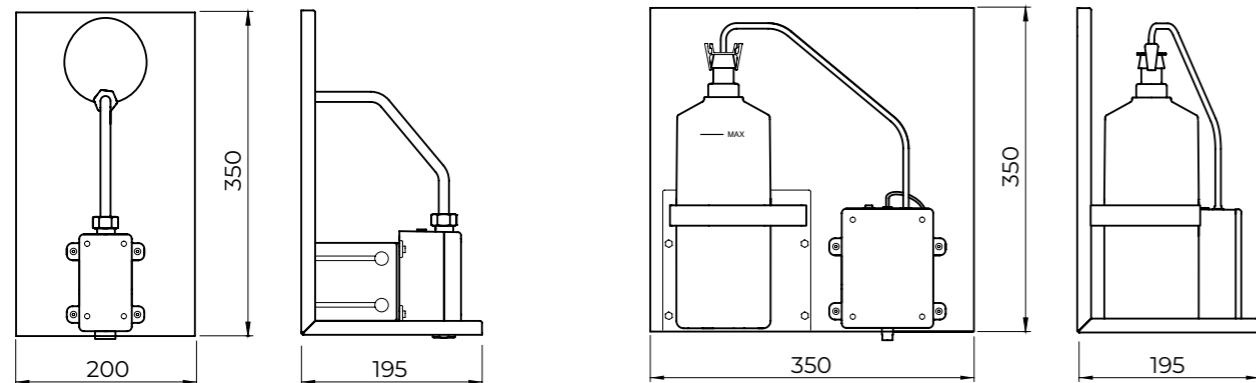

04

Babymedi® transforms the concept of baby changing stations by combining cutting-edge design, durability, technology, and hygiene. This sophisticated solution ensures **the highest levels of comfort**

and safety for babies. Available in both **horizontal and vertical** options, for **wall-mounted or recessed** installation, Babymedi® presents a range of exclusive finishes ideal for public spaces that

require flawless aesthetics. With sleek lines and rounded edges, its designs integrate seamlessly into any setting, ensuring **hygiene, comfort, and safety**.

CHANGING STATIONS

04

babymedi®

CHANGING STATIONS

Available in both **horizontal and vertical** orientations, along with a range of unique finishes, Babymedi® offers versatile integration options to suit any space.

Additionally, the Babymedi® **recessed kit** allows for **seamless and sophisticated integration** into the washroom, enhancing the space's design with elegance.

Featuring **BIOCOTE® and ION HYGIENIC® technology**, these changing stations provide an exceptional level of hygiene, ensuring enhanced protection for babies.



Highest hygiene, safety
and integration



babymedi®

HORIZONTAL

- Surface treated with BIOCOTE® antimicrobial protection.
- Ergonomic design, easily adaptable to any environment.
- ION HYGIENIC® technology neutralizes virus and bacteria on the surface when closed.
- Equipped with a bag hanger and safety belt for added convenience and security.
- Includes a sanitizing wipes dispenser for enhanced hygiene.



WHITE BLACK SATIN PVD COATING

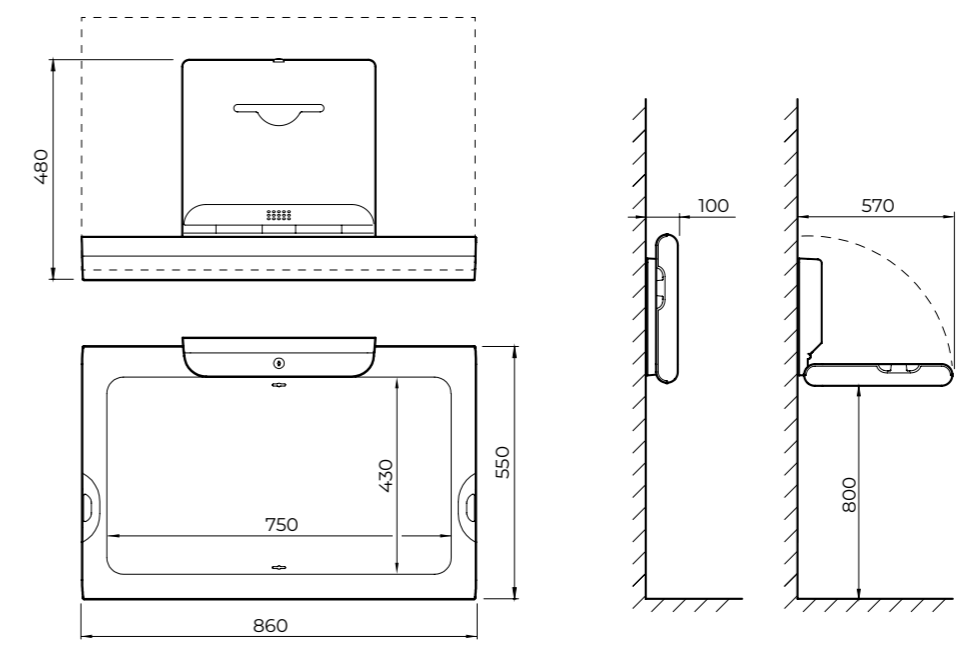



babymedi®

VERTICAL

- Surface treated with BIOCOTE® antimicrobial protection.
- Ergonomic design, easily adaptable to any environment.
- ION HYGIENIC® technology neutralizes virus and bacteria on the surface when closed.
- Equipped with a bag hanger and safety belt for added convenience and security.
- Includes a sanitizing wipes dispenser for enhanced hygiene.



WHITE



BLACK



SATIN



PVD COATING

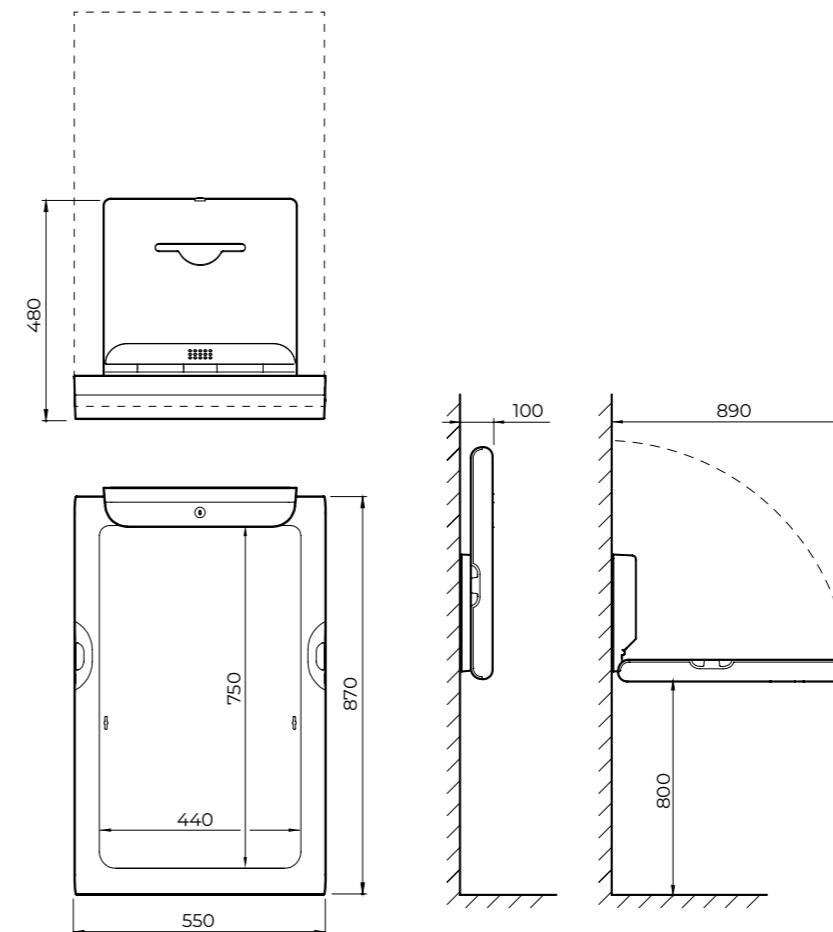



babymedi®

RECESSED KIT

- Available in both horizontal and vertical options.
- Perfect for compact washrooms, maximizing space efficiency.
- Complies with ADDAG accessibility regulations, ensuring inclusivity.
- Offered in a variety of finishes, seamlessly matching the changing station.



SATIN

BLACK

PVD COATING

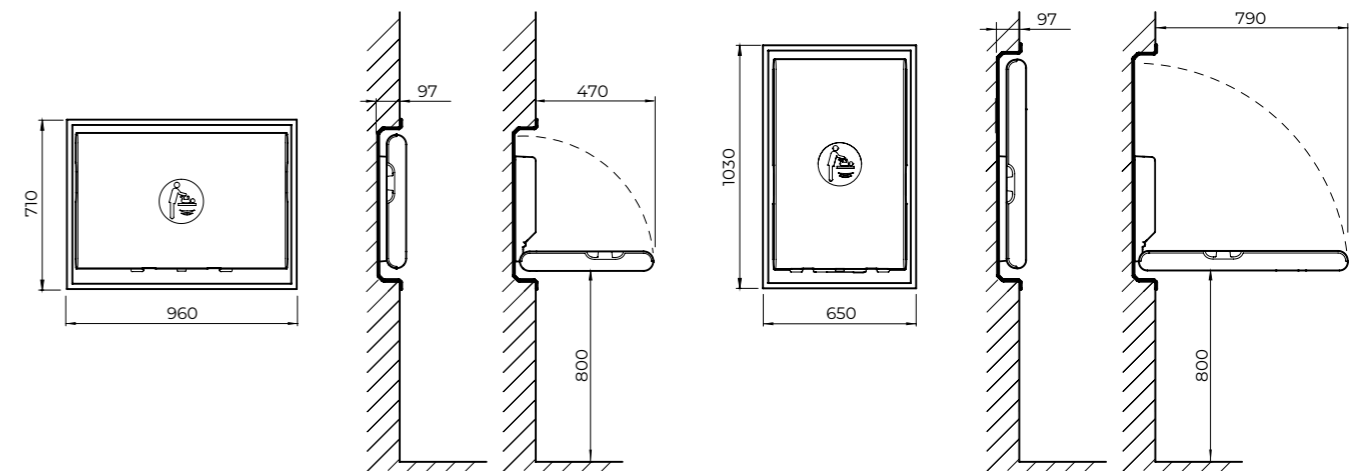

ADA Compliant

05

High-capacity automatic solutions built for **outstanding durability**. The perfect blend of

functionality and style, featuring meticulously crafted finishes and smooth, clean surfaces that

ensure seamless integration into any washroom. Ideal for **high-traffic areas**.

SOAP DISPENSERS



05

SOAP DISPENSERS

Our high-capacity automatic models feature meticulous finishes with **smooth, clean surfaces**, ensuring seamless integration into the washroom.

Equipped with a soap level display on the front of the dispenser, these models allow easy monitoring of the soap supply, ensuring **quick and efficient maintenance** at all times.



Functionality and style for high-traffic areas

SOAP DISPENSERS

- Operated by sensor.
- Large capacity (1 L).
- Allows different types of soap: liquid, foam or spray, by interchanging valves.
- Optional: 9V TRAF0 power adapter for direct connection to power supply.



WHITE



BLACK



SATIN



BRIGHT



PVD COATING

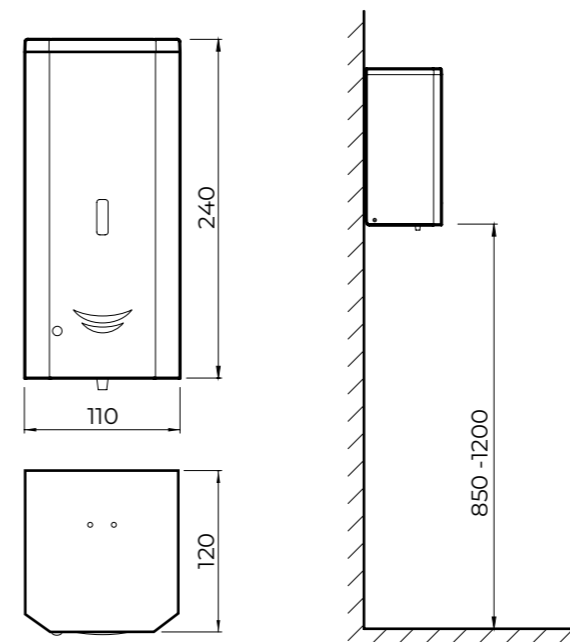

06

Large-capacity toilet paper dispensers that blend **functionality with elegance.** Their design ensures seamless

integration into any bathroom, featuring sleek, sophisticated lines without sharp edges or corners. Crafted from **high-**

quality steel, they offer both durability and style.



TOILET PAPER DISPENSERS

06

TOILET PAPER DISPENSER

Designed to withstand the demands of high-traffic spaces, this dispenser combines high capacity, strength and functionality, offering a **durable and efficient solution**.

Manufactured in **AISI 304 stainless steel**, its circular design not only ensures hygiene and resistance, but also includes a **front viewer and vandal-proof lock** for greater convenience and safety.



High capacity and
resistance



TOILET PAPER DISPENSER

- High capacity dispenser.
- Compatible with various paper refill sizes.
- Vandal-proof lock for enhanced security.
- Front viewer for easy refill monitoring.
- Anti-twist brake to prevent waste and ensure efficient paper dispensing.
- Also available in a larger size (Ø 275 mm).

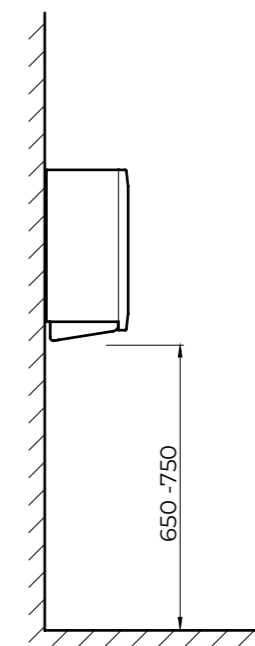
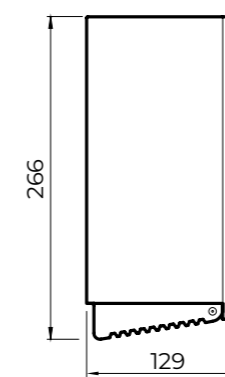
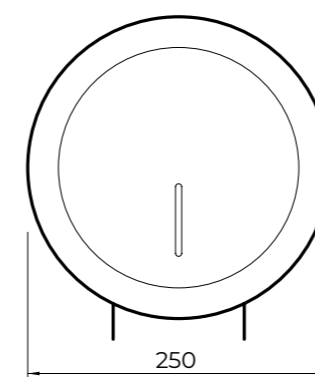

07

Solutions designed for **functionality and style**. Easy to integrate into any washroom

setting, they combine aesthetics and resistance. Perfect to install in **high-traffic areas**, they offer exceptional efficiency and long-lasting performance.

TOWEL PAPER DISPENSERS



07

PAPER TOWEL DISPENSER

Manual paper towel dispenser featuring a compact, vandal-proof design with no sharp edges. Designed for **efficient paper usage**, it includes a special safety lock for reliable and secure operation.

Ideal for various washroom settings, it caters to users seeking efficiency, comfort, and exceptional durability in high-traffic spaces that prioritize **strength, functionality, and hygiene**.



Durability and efficiency for high-traffic settings



PAPER TOWEL DISPENSER

- Compact, sturdy, and vandal-proof design.
- High capacity for extended use.
- Secure lock with an opening key.
- Transparent content viewer for easy refill monitoring.
- Smooth, rounded edges for safety.



WHITE

BLACK

SATIN

BRIGHT

PVD COATING

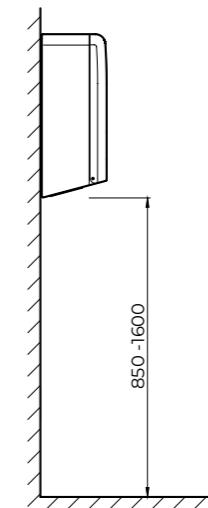
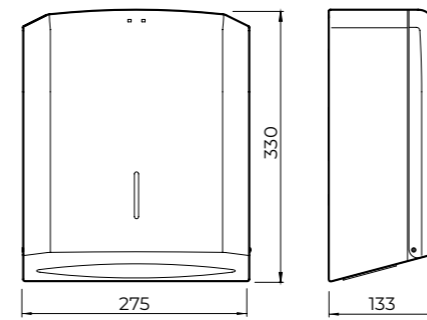

08

AISI 304 steel wastepaper bins in various capacities, designed for **easy and efficient maintenance.**

These reliable and functional solutions are ideal

for collecting different types of waste, with a versatile design that ensures seamless integration into any washroom setting.

BINS

08

BIN

CAPACITY 25 L.

Manufactured in AISI 304 steel, this wastepaper bin series feature a functional and versatile design that adapts seamlessly to various settings, ensuring **easy and efficient maintenance**.

With clean, minimalist lines, these bins provide a practical waste collection solution while **integrating elegantly into any washroom**. They are the ideal choice for indoor public areas with moderate traffic.



Clean and organized settings
with a minimalist design

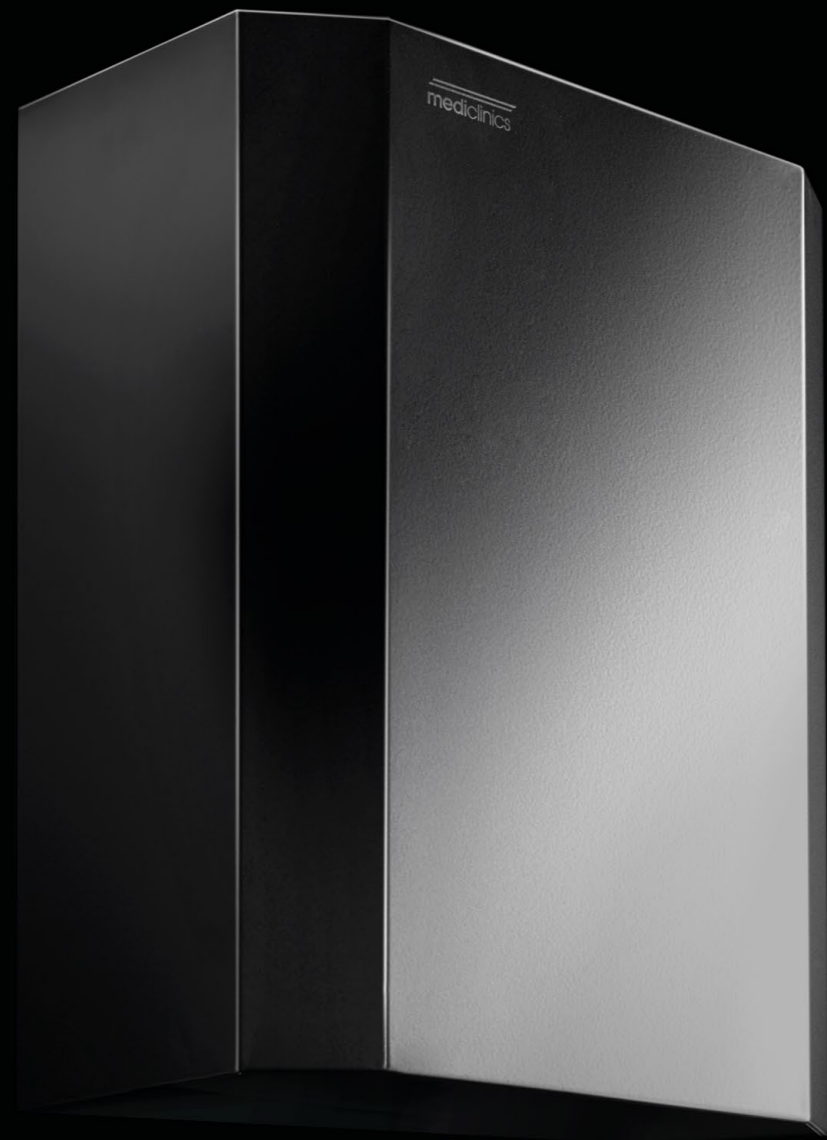

BIN

CAPACITY 25 L.

- Welded structure with smooth edges, free of burrs or sharp corners to prevent cuts.
- Plastic ring for secure bag placement.
- Available in stainless steel or epoxy-painted finishes.
- Also available in a 40 L version.



BLACK



SATIN



BRIGHT



PVD COATING

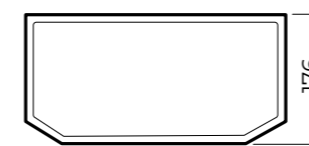
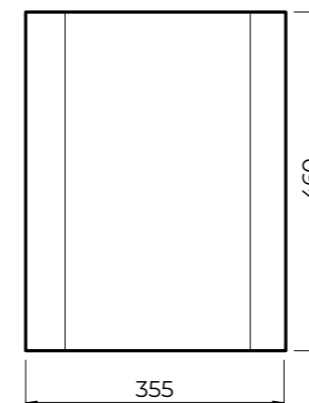

08

BIN

CAPACITY 65 L.

This container is designed for **high-traffic areas**.

Made of AISI 304 stainless steel, it features minimalist lines and smoothly rounded edges, ensuring seamless integration into any space.

Equipped with a manual self-closing lid, it offers optimal hygiene while maintaining a stylish design. The container also includes a **fastening system** and four cylindrical rubber plugs at the base, protecting the bottom from moisture.



Self-closing lid for an optimal hygiene



BIN

CAPACITY 65 L.

- High-capacity container for efficient waste management.
- Self-return lid ensures better hygiene.
- Welded structure with smooth edges, free of burrs or sharp corners to prevent cuts.
- Secure fastening system to keep the waste bag in place.
- Also available in an 80 L version.



WHITE



SATIN



BRIGHT

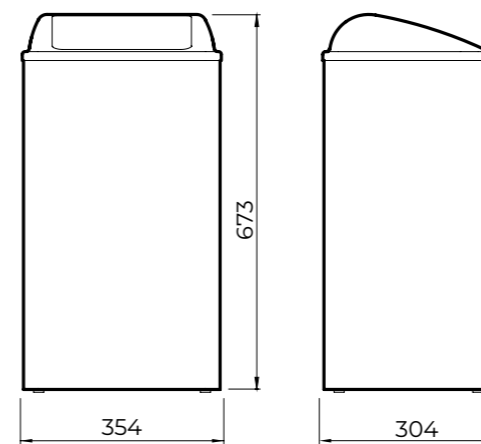

09

Our designs are sophisticated and resistant, perfect to transform and enhance the most exclusive washrooms in hotels and residences. Each accessory features **delicate and refined shapes**, conceived for **spaces that seek to stand**

out for their uniqueness and excellence. We are committed to blend exceptional durability with impeccable style, ensuring beauty and functionality in perfect harmony.

BATHROOM ACCESSORIES

09

AURA SERIES

The AURA series accessories are distinguished by their smooth, rounded finishes.

Made from shiny, satin, or black AISI 304 stainless steel, **they seamlessly integrate into any setting**, offering a remarkable sense of comfort during everyday bathroom routines.



Rounded lines and
pleasant touch



AURA TOWEL RACKS AND RAILS

The Aura series offers a variety of options to place towels:

- Towel rack featuring a top bar for resting towels and a bottom bar for hanging multiple towels, thanks to its double-bar design.
- Towel rail with two bars for greater capacity.
- Towel rail with one bar for direct access to the towel.

FINISH: BRIGHT BLACK SATIN



Towel rack



Double towel rail



Towel rail

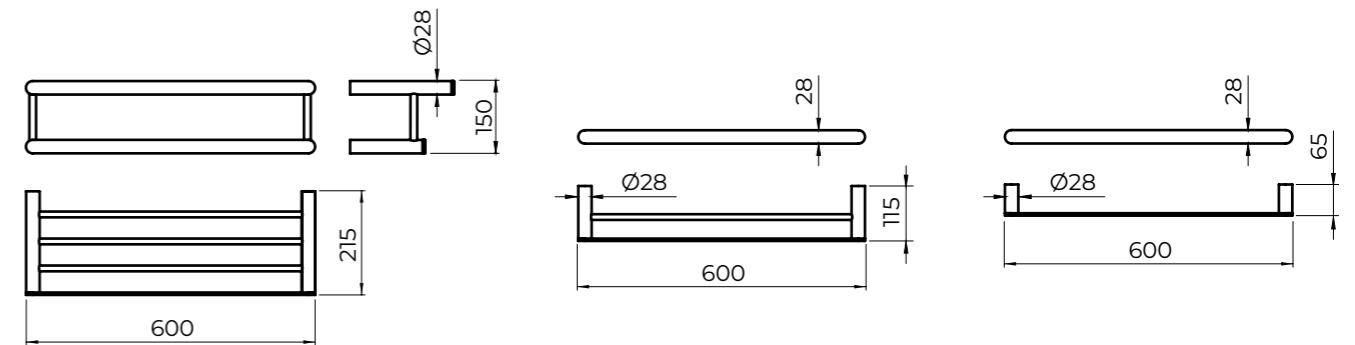



AURA TOILET ROLL HOLDERS

The Aura series offers multiple options for toilet paper storage:

- Aura double toilet roll holder with tray for greater capacity and less maintenance.
- Single toilet roll holder with an integrated tray on top for placing accessories.
- Reserve toilet roll holder for an additional roll.

FINISH: BRIGHT BLACK SATIN



Double toilet roll holder



Toilet roll holder



Reserve toilet roll

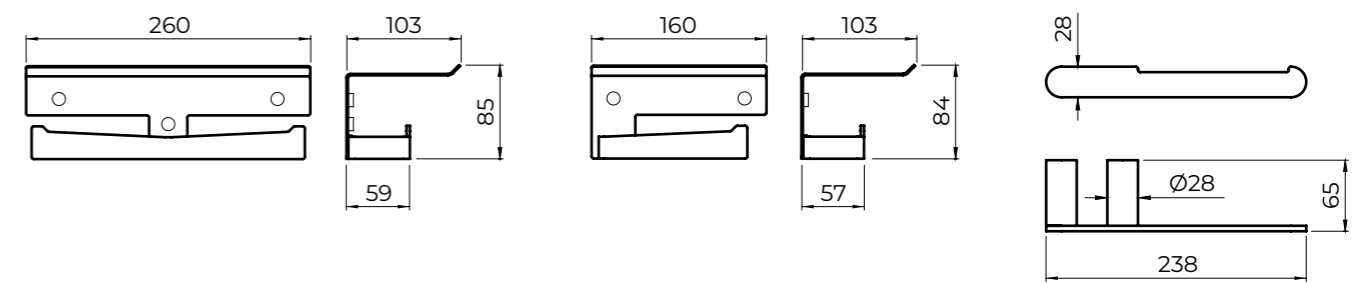
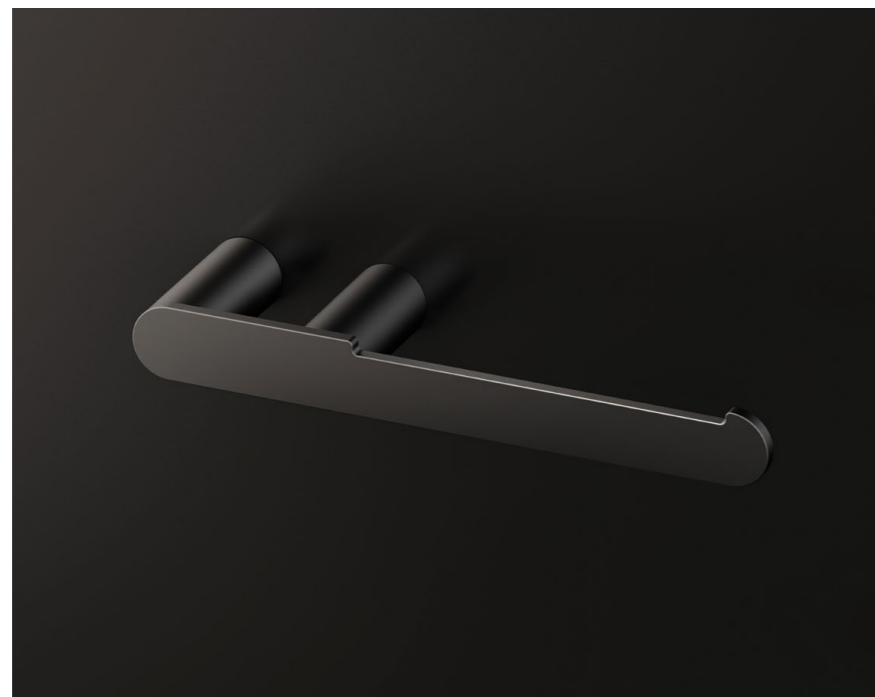



AURA HANGERS AND TOILET BRUSH HOLDERS

- Double-hook hanger, designed to hold multiple garments or towels at once.
- Single-hook hanger for hanging clothes or a towel.
- Toilet brush holder with an integrated anchoring system, blending seamlessly into the space. Its raised position makes it easy to clean and maintain.

FINISH: BRIGHT BLACK SATIN



Double-hook hanger



Single-hook hanger



Toilet brush holder

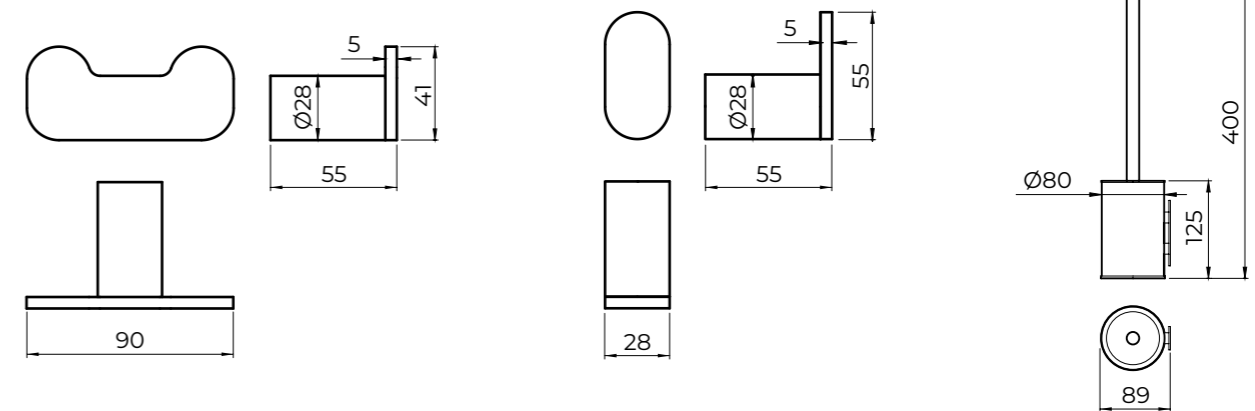

09

HARMONIA SERIES

The HARMONIA series accessories feature sleek, straight lines that **seamlessly integrate into any bathroom.**

With a wide range of finishes available, they help create unique, stylish bathrooms in exceptional spaces. Crafted for everyday use, these accessories are a **durable, high-quality solution.**



Straight lines that evoke
sense of balance



HARMONIA TOWEL RACKS AND RAILS

The Harmonia series offers a variety of options to place towels:

- Towel rack featuring a top bar for resting towels and a bottom bar for hanging multiple towels, thanks to its double-bar design.
- Towel rail with two bars for greater capacity.
- Towel rail with one bar for direct access to the towel.

FINISH: BRIGHT BLACK SATIN

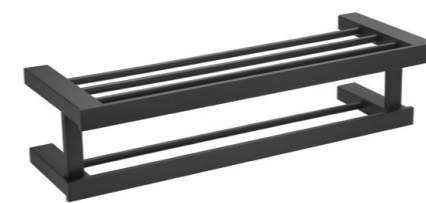

Towel rack



Double towel rail



Towel rail

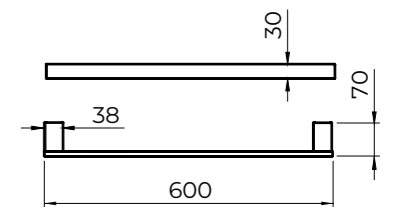
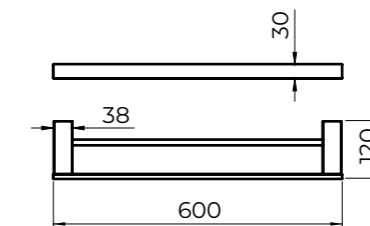
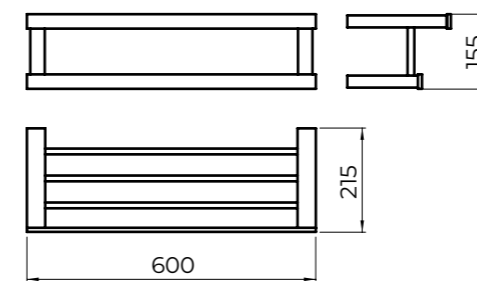

HARMONIA TOILET ROLL HOLDERS

The Harmonia series offers multiple options for toilet paper storage:

- Double toilet roll holder with tray for greater capacity and less maintenance.
- Single toilet roll holder with an integrated tray on top for placing accessories.
- Reserve toilet roll holder for an additional roll.

FINISH: BRIGHT BLACK SATIN



Double toilet roll holder



Toilet roll holder



Reserve toilet roll

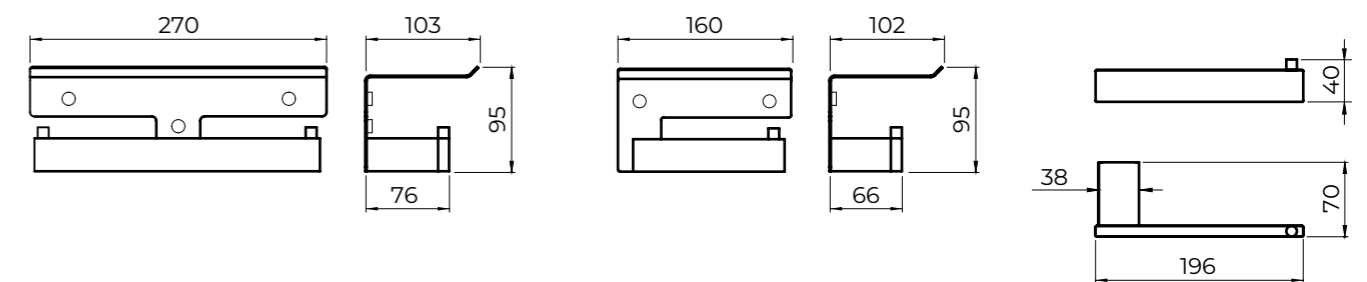



HARMONIA HANGERS AND TOILET BRUSH HOLDERS

- Double-hook hanger, designed to hold multiple garments or towels at once.
- Single-hook hanger for hanging clothes or a towel.
- Toilet brush holder with an integrated anchoring system, blending seamlessly into the space. Its raised position makes it easy to clean and maintain.

FINISH: BRIGHT BLACK SATIN

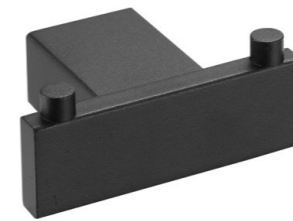

Double-hook hanger



Single-hook hanger



Toilet brush holder

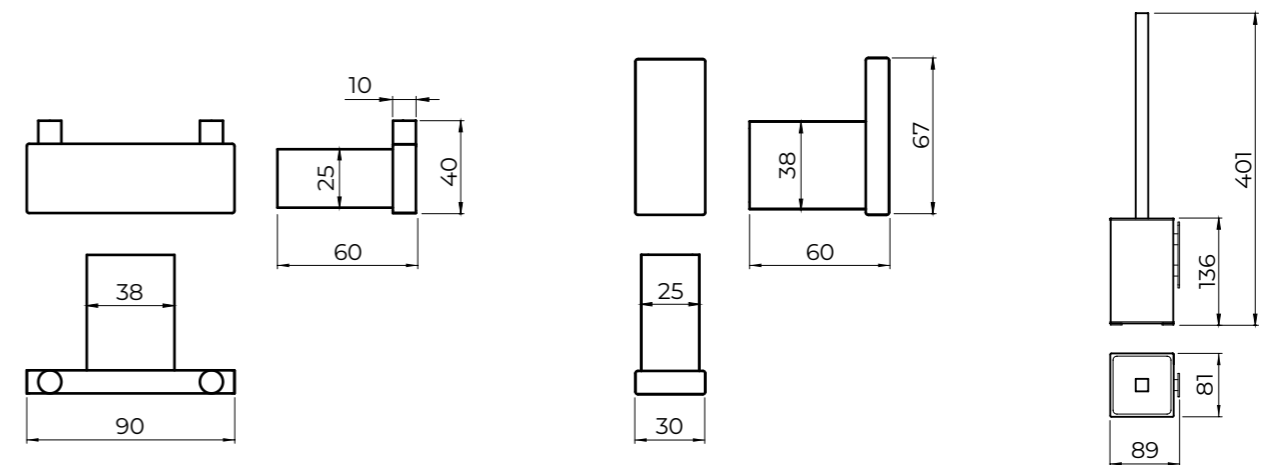
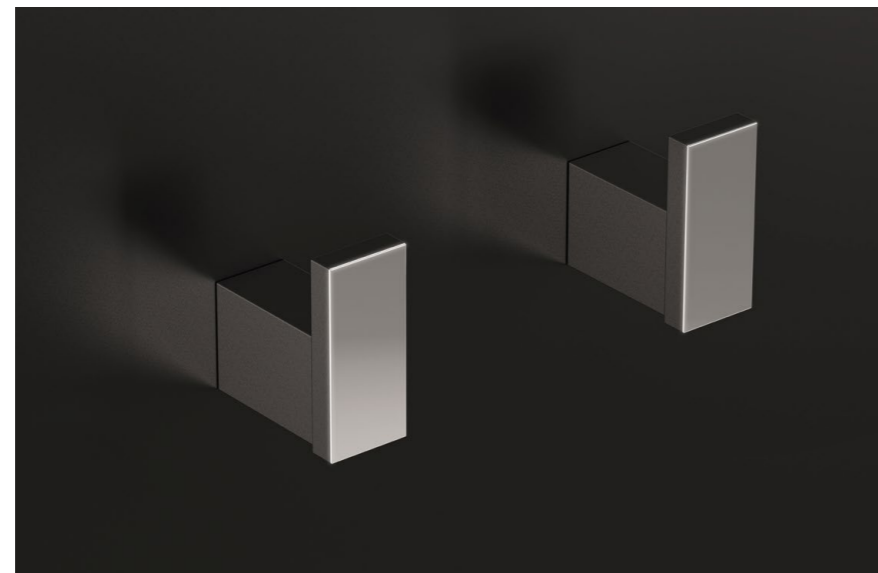

PVD

PVD (Physical Vapor Deposition) is an advanced coating technique that offers a high quality finish, durability and aesthetics. Available colors: gold, copper, bronze and anthracite finish.

SOFISTICATION

Metallic finishes provide an appearance of luxury and sophistication. The color's stability ensures long-lasting brightness.

RESISTANCE

Provides greater resistance to wear, abrasion, corrosion and scratches, prolonging the product's life and guaranteeing a superior quality finish.

SUSTAINABILITY

PVD is eco-friendly, being free from harmful chemicals and not producing hazardous waste.



GOLD

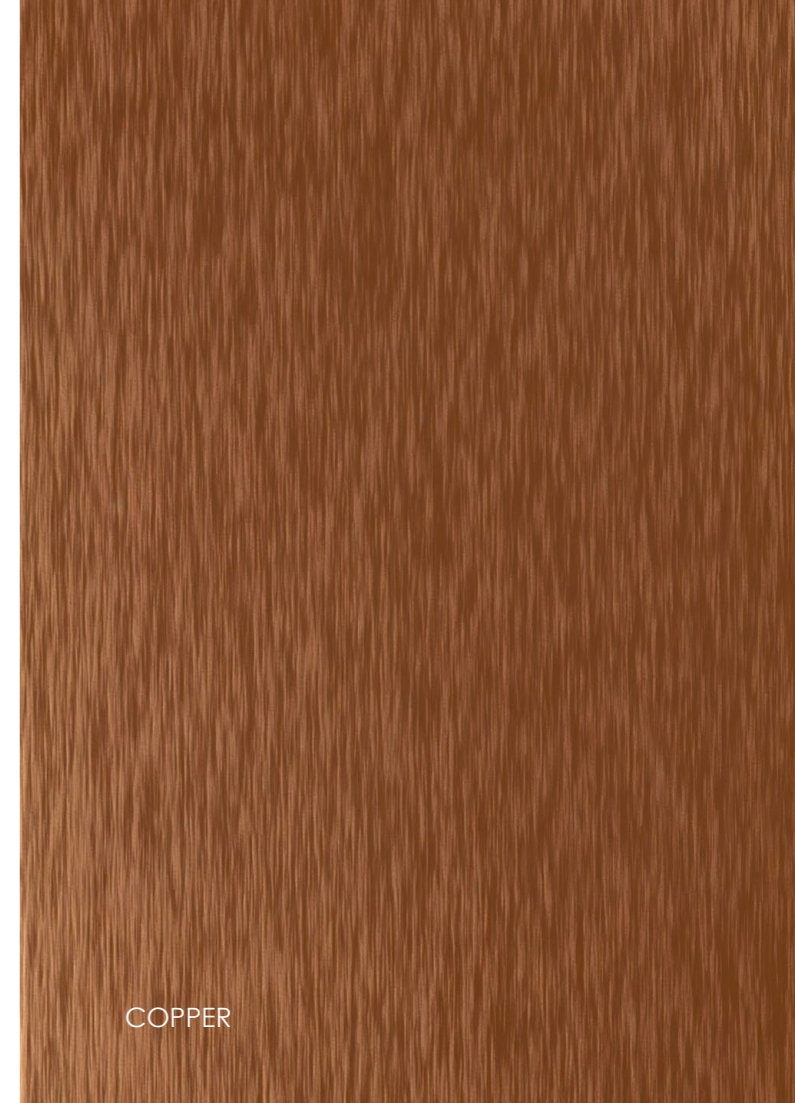

COPPER

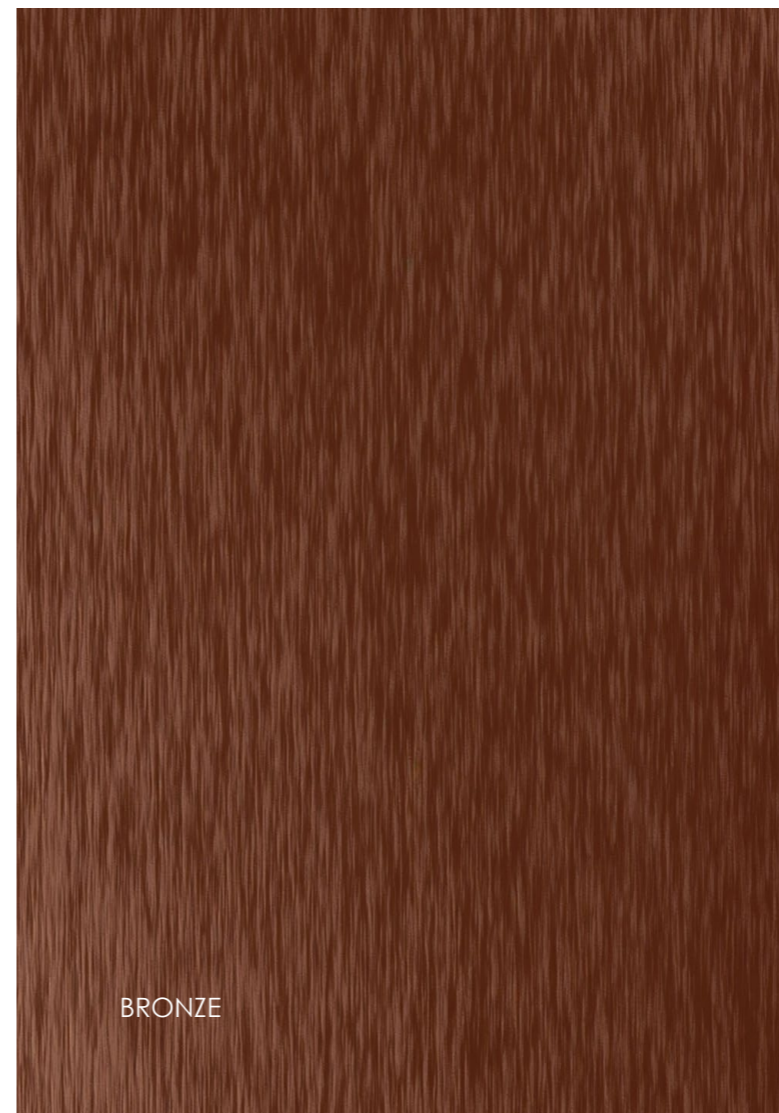

BRONZE



ANTHRACITE



REFERENCES

AIRPORTS

JFK International Airport, New York (USA)
Charles de Gaulle International Airport, Paris (France)
Istanbul International Airport (Turkey)
Barcelona International Airport (Spain)
Chennai International Airport (India)
Monterrey International Airport (Mexico)
Sydney International Airport (Australia)
Clark International Airport (Philippines)

CASINOS

Sydney Opera house and Casino (Australia)
The Crow Casino Melbourne (Australia)
Lloret de Mar Casino (Spain)

SHOPPING CENTERS

Bangsar Shopping Centre, Kuala Lumpur (Malaysia)
Top Ryde Shopping Centre (Australia)
Miraflores Shopping Centre (Guatemala)
Taikon Place Shopping Centre (Hong Kong)
Polo Park Shopping Centre, Winnipeg (Canada)
An Phu Plaza, Ho Chi Minh City (Vietnam)

GYMS AND SPAS

Metropolitan Fitness Center (Spain)
Health Works Fitness, Queensland (Australia)
DIR Fitness Centers (Spain)
Reebok Sports Club, Madrid (Spain)
Barcino Tennis Club, Barcelona (Spain)

CINEMAS AND THEATERS

Brodway Cinema at Hollywood Plaza (Hong Kong)
Royal Opera House (Oman)
Royal Theatre, Madrid (Spain)
La Casona Theatre, Buenos Aires (Argentina)
Century Cinemas (USA)
UGC Cinemas, Paris (France)

RACE TRACKS

Yas Marina Circuit, Abu Dhabi (United Arab Emirates)
Meydan Racecoude, Dubai (United Arab Emirates)

SCHOOLS

San José School (USA)
York College of Pensilvania (USA)
Polymechanics School, Quebec (Canada)
Sainte Thérèse Academy, Quebec (Canada)
Harrow International School (Singapur)
The Hills Sports High School, Sidney (Australia)
Joaquin Blume Residence, Barcelona (Spain)

STADIUMS

Dodger Stadium, Los Angeles (USA)
Ibn Batouta Stadium, Tangier (Morocco)
London Olympic Stadium (UK)
Old Trafford Stadium (UK)
Sydney Olympic Stadium (Australia)
L'Alqueria Basket, Valencia (Spain)

RAIL STATIONS

Hong Kong MTR Stations (Hong Kong)
Buquebus Central Station, Buenos Aires (Argentina)

HOSPITALS

South Lake Hospital Clemont, Florida (USA)
Santa Creu i Sant Pau Hospital (Spain)
Queen Mary Hospital (Hong Kong)
San Marco Hospital, Latina (Italy)
Ghayathi Hospital, Abu Dhabi (United Arab Emirates)
Skolkovo Hospital Moscow (Russia)
Stradini Hospital Riga (Latvia)



HOTELS

Grand Hyatt Chicago Hotel (USA)
Crown Regency Hotel, Manila (Philippines)
Best Western Sumadja, Belgrade (Serbia)
Sheraton Hotel, Montevideo (Uruguay)
Melia-Hotusa and AC Hotel (Spain)
Shamal Shera Resort (Philippines)
Ritz Carlton Hotel (Bahrain)
Intercontinental Hotel, Johannesburg (South Africa)

MUSEUMS

Brooklyn Children's Museum, New York (USA)
Alexander Museum, Tel Aviv (Israel)
Guggenheim Museum, Bilbao (Spain)
El Prado Museum, Madrid (Spain)
National Museum, Warsaw (Poland)
Diocesan and Regional Museum, Barcelona (Spain)

THEME PARKS

Port Aventura, Tarragona (Spain)
Delaware State Amusement Park (USA)
Sentosa Island Theme Park (Singapur)

RESTAURANTS

NBA Café, Barcelona (Spain)
Tramvai, Milan (Italy)
Dunkin Donuts (USA)
McDonald's, Europe
Burger King, Europe
Arby's restaurants (USA)

UNIVERSITIES

Florida Atlantic University (USA)
National University of Singapore (Singapore)
Pennsylvania State University (USA)
Queen Mary University of London (UK)
University of California, Berkeley (USA)
Montevideo University of Architecture (Uruguay)
ESADE Business School, Barcelona (Spain)
Australian National University in Canberra (Australia)

OTHER

New York Stock Exchange (USA)
Ohio State Penitentiary (USA)
Broward Judicial Court (USA)



Mediclinics S.A.
Industria 54, 08025 Barcelona
T. +34 934 464 700
arquitectos@mediclinics.com
www.mediclinics.com