

# AERO®

## PRODUCT INFORMATION



# TABLE OF CONTENTS

<b>Description</b> .....	<b>3</b>
<b>Benefits</b> .....	<b>4</b>
Design .....	4
Quality .....	4
Customization .....	5
Comfort .....	5
<b>Technical details</b> .....	<b>6</b>
Standard configuration .....	7
Aero > 6055 mm .....	8
Aero weight .....	9
Aero snow load .....	10
<b>Accessories</b> .....	<b>12</b>
<b>Certificates &amp; testing</b> .....	<b>14</b>
<b>Determination of occurring forces</b> .....	<b>15</b>
<b>Configuration</b> .....	<b>16</b>
Type .....	16
Construction method .....	16
Dimensions .....	17
Profiles .....	19
Motor control .....	20
Blade orientation .....	21
Installation .....	22
Water drainage .....	24

<b>Installation</b> .....	<b>28</b>
Installation .....	28
Drainage connection .....	29
Finish .....	30
Sealing .....	31
<b>Other tools</b> .....	<b>32</b>





SUN PROTECTION VENTILATION WATERPROOF

## DESCRIPTION

**A horizontal, water-repellent sun protection roof with rotatable blades that can be integrated perfectly into new or existing structures.**

- Can be controlled using RTS
- Minimalist and sleek design for subtle integration
- Matches all architectural styles
- Customized with millimetre precision
- Protection from the sun, rain and wind



One roof section



Hurricane Cat 1

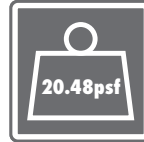

# BENEFITS

## Design



### 1 MINIMALIST DESIGN

---

### 2 INVISIBLE SCREWS

---

Create an elegant and sleek structure

### 3 MINIMAL GAPS BETWEEN THE BLADES

---

Lend a stunning and sleek finish

## Quality



### 1 F2 TECHNOLOGY

---

#### INNOVATION

Every blade is secured to the frame to create a strong and stable structure

### 2 SPLASH PREVENTION

---

Via integrated water channels with diffusers

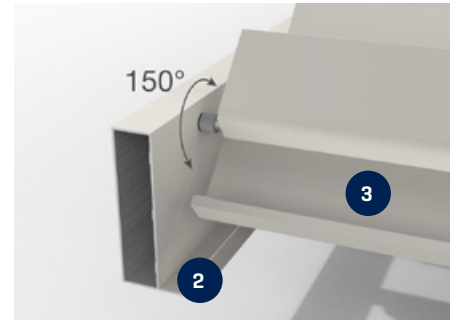

### 3 HIGH WATER DRAINAGE FLOW

---

Through the wide blade gutters

### 4 DOUBLE-WALLED BLADES FOR EXTRA STRENGTH

---

Load-bearing capacity: 20.48psf

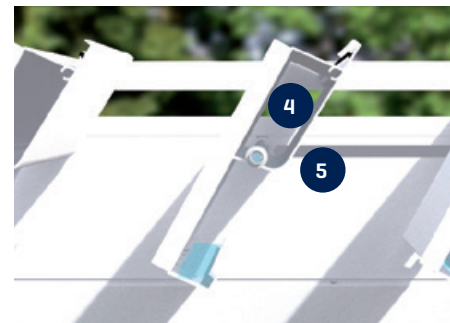

### 5 WELDED ALUMINIUM DRIPS, POWDER COATED TO MATCH THE COLOR OF THE ROOF BLADES

---

### 6 UNIQUE END CAPS PROVIDE STRONG CORNER JOINTS

---

## Customization

For more information about the possible accessories, see the 'Accessories' section and/or the product information for the various accessories.

## Comfort

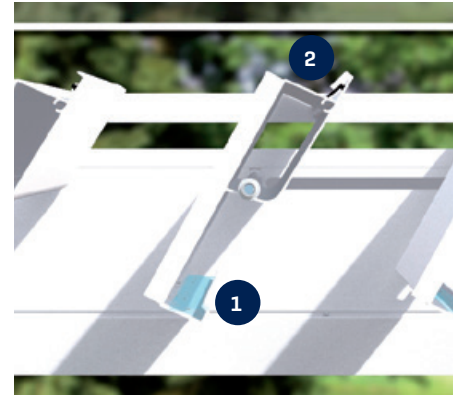

### **1 SPECIALLY DEVELOPED GUTTER BORDER**

---

#### **INNOVATION**

Prevents your patio and furniture from getting wet when the blades are opened following a rain shower

### **2 SILENT AND SOFT CLOSING MECHANISM BY ADDING A BRUSH TO THE BLADES**

---

### **3 QUICK INSTALLATION**

---

Thanks to maximum pre-assembly and the modular structure of the various junctions

### **4 MAXIMUM NATURAL LIGHT**

---

Blades open through 150°

# TECHNICAL DETAILS



Dimensions	
Span – Single	Min. 71"* - max. 177"
Span – Single with additional beam	Min. 71"* - max. 236"
Pivot	Min. 102"* - max. 238"
Passage height	N/A
Total height with blades closed	9 1/16"
Total height with blades 90° open	9 1/16" + 3 47/64"
Blade rotation	Max. 150°
Customisation	Span and pivot: made to measure
Minimum number of water drainage points < 172sqft	1
Minimum number of water drainage points > 172sqft	2
Operating methods	
Somfy RTS	✓
Home automation ready	✓

\* Smaller dimensions (span min. 32" and pivot min. 43 45/64") possible by special request to pre-sales - drawing office.

## Electrical bladed roof drive

Parameters	Value
Supply voltage	110 Volt AC, 50 Hz
Transformer current range	0 - 2.5 Ampère
Transformer power	100 W
Motor voltage	24 Volt DC
Motor nominal current	3 Ampère
Protection rating	IP 66 Dynamic
Maximum running time with continuous use	Approx. 2 minutes
Automatic	16 A Curve C

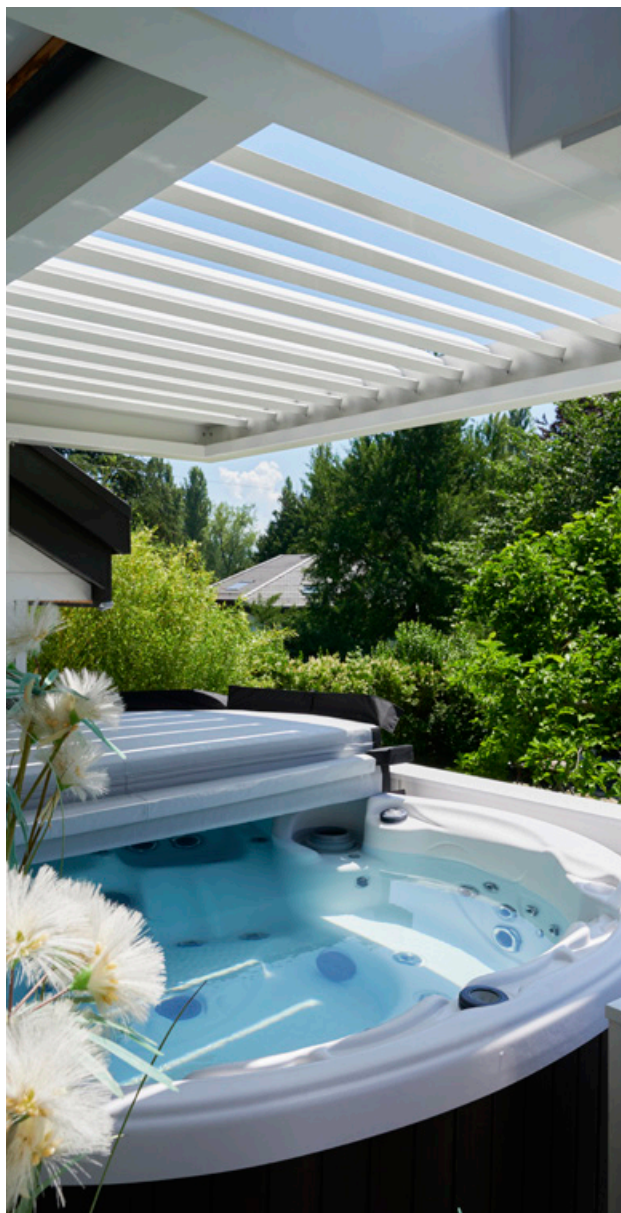

## Standard configuration

### Construction

- Roof structure to be placed on top of or to be integrated in an existing support structure
- Custom span to the mm and pivot per blade step or to the fraction of an inch
- Motor drive with choice of motor position and drainage
- Blade orientation [sun protection or maximum sunlight]

### Finish

- Seaside Quality A
- Monocolour or dual color according to Renson standard colours
- Integrated water drainage [incl. anti-splash diffusers in the gutter]

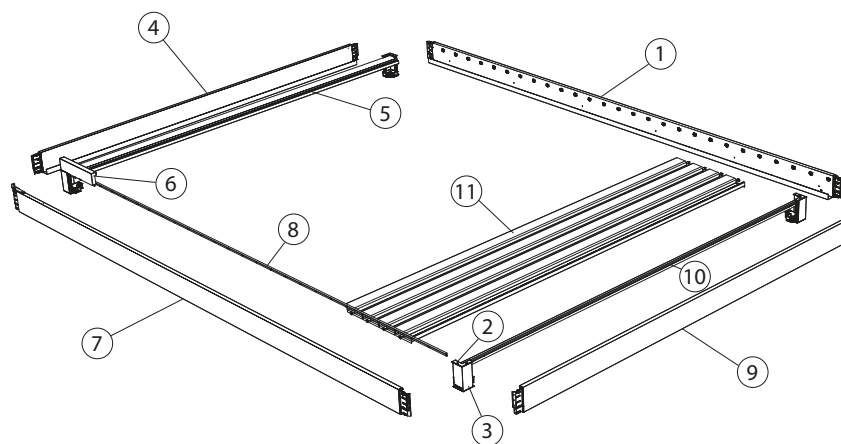

1	Pivot beam 1
2	Top cover
3	Inner cover
4	Span beam 2
5	Fixed blade
6	Motor + cover
7	Pivot beam 2
8	Driving profile
9	Span beam 1
10	Sealing profile
11	Blade





## Aero weight

Total weight (lbs) of entire Aero																	
Span																	
	Dimensions in inches	# blades	70	78	86	94	102	110	118	125	133	141	149	157	165	173	177
Pivot	102	11	320	342	362	386	408	428	450	470	492	514	534	556	576	600	611
	111	12	340	360	384	408	430	452	474	499	521	543	565	587	613	635	646
	119	13	358	382	406	428	452	477	501	525	549	571	596	622	646	671	682
	128	14	377	400	426	450	474	501	525	552	576	602	629	655	680	706	717
	136	15	397	419	446	472	499	525	552	578	605	633	660	686	713	739	754
	145	16	415	437	466	492	521	549	576	605	635	664	691	719	748	774	790
	153	17	435	455	486	514	543	574	602	633	664	693	721	752	781	810	825
	162	18	452	474	505	536	567	598	629	660	691	721	752	783	814	845	860
	170	19	472	492	525	556	589	622	655	688	719	752	783	816	847	880	896
	179	20	490	512	545	578	613	646	682	715	748	781	814	847	882	915	933
	187	21	508	530	565	602	635	671	706	741	777	810	845	880	915	953	971
	196	22	527	547	587	622	660	695	732	768	803	840	876	913	951	988	1006
	204	23	545	569	607	644	682	719	757	794	832	869	907	946	984	1021	1041
	212	24	567	587	627	666	704	743	783	821	860	902	940	979	1019	1057	1076
	221	25	585	607	646	686	728	768	807	847	891	931	971	1012	1052	1092	1112
	229	26	605	624	666	708	750	792	834	878	918	960	1001	1043	1085	1127	1147
	238	27	622	644	686	730	772	816	860	904	946	990	1032	1076	1118	1162	1184

## Aero snow load

### Single Aero

For span lengths < 3625 mm, the load-bearing capacity is determined by the pivot length. For span lengths > 3625 mm, the load-bearing capacity is no longer determined by the pivot dimensions, but exclusively by the span length [blade length] instead.

		Maximum snow load single Aero (psf)																
		Span																
Pivot	Dimensions in inches	# blades	70	78	86	94	102	110	118	125	133	141	149	157	165	173	177	
		102	11	275	247	224	205	165	132	107	88	73	61	52	44	38	32	30
		111	12	232	209	190	174	160	132	107	88	73	61	52	44	38	32	30
		119	13	199	179	162	149	137	127	107	88	73	61	52	44	38	32	30
		128	14	172	155	140	129	118	110	102	88	73	61	52	44	38	32	30
		136	15	150	135	123	112	103	96	89	83	73	61	52	44	38	32	30
		145	16	132	119	108	99	91	84	79	73	69	61	52	44	38	32	30
		153	17	117	105	96	87	81	75	70	65	61	57	52	44	38	32	30
		162	18	105	94	85	78	72	66	62	58	54	51	48	44	38	32	30
		170	19	94	84	77	70	64	60	55	52	49	46	43	41	38	32	30
		179	20	85	76	69	63	58	54	50	47	44	41	39	37	35	32	30
		187	21	77	69	62	57	52	48	45	42	39	37	35	33	31	30	29
		196	22	70	63	57	52	48	44	41	38	36	34	32	30	29	27	27
		204	23	62	56	50	46	42	39	36	34	32	30	28	27	25	24	23
		212	24	54	49	44	40	37	34	32	30	28	26	24	23	22	21	20
		221	25	48	43	39	35	32	30	28	26	24	23	21	20	19	18	18
		229	26	42	38	34	31	28	26	24	23	21	20	19	18	17	16	15
	238	27	37	33	30	27	25	23	21	20	19	18	16	15	15	14	13	

## Single Aero with additional beam

The static snow load in a symmetrical single Aero structure with an additional beam is shown in the table below.

		Maximum snow load single Aero with additional beam (psf)																							
		Span																							
Pivot	Dimensions in inches	# blades	1800	2000	2200	2400	2600	2800	3000	3200	3400	3600	3800	4000	4200	4400	4500	4600	4800	5000	5200	5400	5600	5800	6000
		102	11	415	330	269	223	188	160	138	120	105	93	83	74	66	60	57	54	49	45	41	38	35	32
	111	12	383	305	248	206	173	148	127	111	97	86	76	68	61	55	52	50	45	41	38	35	32	29	27
	119	13	355	283	230	191	161	137	118	103	90	79	71	63	56	51	48	46	42	38	35	32	29	27	25
	128	14	332	264	215	178	150	128	110	96	84	74	66	58	53	47	45	43	39	35	32	30	27	25	23
	136	15	311	247	201	167	140	120	103	89	78	69	61	55	49	44	42	40	36	33	30	28	25	23	21
	145	16	293	233	189	157	132	112	97	84	73	65	57	51	46	41	39	37	34	31	28	26	24	22	20
	153	17	276	220	179	148	124	106	91	79	69	61	54	48	43	39	37	35	32	29	26	24	22	20	19
	162	18	261	208	169	140	118	100	86	75	65	58	51	46	41	37	35	33	30	27	25	23	21	19	18
	170	19	248	197	160	133	112	95	82	71	62	55	48	43	39	35	33	31	28	26	23	21	20	18	16
	179	20	236	188	152	126	106	90	78	67	59	52	46	41	37	33	31	30	27	24	22	20	19	17	15
	187	21	225	179	146	120	101	86	74	64	56	49	44	39	35	31	30	28	26	23	21	19	18	16	15
	196	22	215	171	139	115	97	82	71	61	53	47	42	37	33	30	28	27	24	22	20	18	17	15	14
	204	23	206	164	133	110	92	79	67	58	51	45	40	35	32	28	27	26	23	21	19	17	16	14	13
	212	24	198	157	128	105	89	75	65	56	49	43	38	34	30	27	26	24	22	20	18	16	15	14	13
	221	25	190	151	123	101	85	72	62	54	47	41	36	32	29	26	24	23	21	19	17	16	14	13	12
	229	26	183	145	118	97	82	69	60	52	45	39	35	31	28	25	23	22	20	18	16	15	14	12	11
	238	27	176	140	114	94	79	67	57	50	43	38	33	30	27	24	23	21	19	18	16	14	13	12	11

# ACCESSORIES



Comfort pack		Back order
Fixscreen + Lineo Led	-	-
<b>Side inserts</b>		
Integrated Fixscreen	-	-
Algarve Fixscreen	-	-
Lapure Fixscreen	-	-
Triangle	-	-
Loggia sliding panels	-	-
Loggiascreen Canvas sliding door	-	-
Glass sliding panels	-	-
Linius wall*	-	-
Linarte wall*	-	-
Outdoor curtains	-	-
<b>Comfort</b>		
<b>Lighting</b>		
Lineo Led	✓	-
UpDown Led	✓	✓
Colomno Led	-	-
Lapure Led	-	-
<b>Comfort and design</b>		
Beam Heat & Sound	-	✓
Lineo Luce	-	✓
Lineo Fix	✓	-
Lineo Heat	-	-
Waterproof wall mounting	-	-
Protecto protective profile	✓	✓
<b>Automation</b>		
Wind sensor	✓	✓
Rain sensor	✓	✓
Sun sensor	-	-

Styling		Back order
Classic Line	-	-
Wooddesign roof blades	-	-
Columns		
Extra column	-	-
Shifted column	-	-
Adjustable wall column	-	-

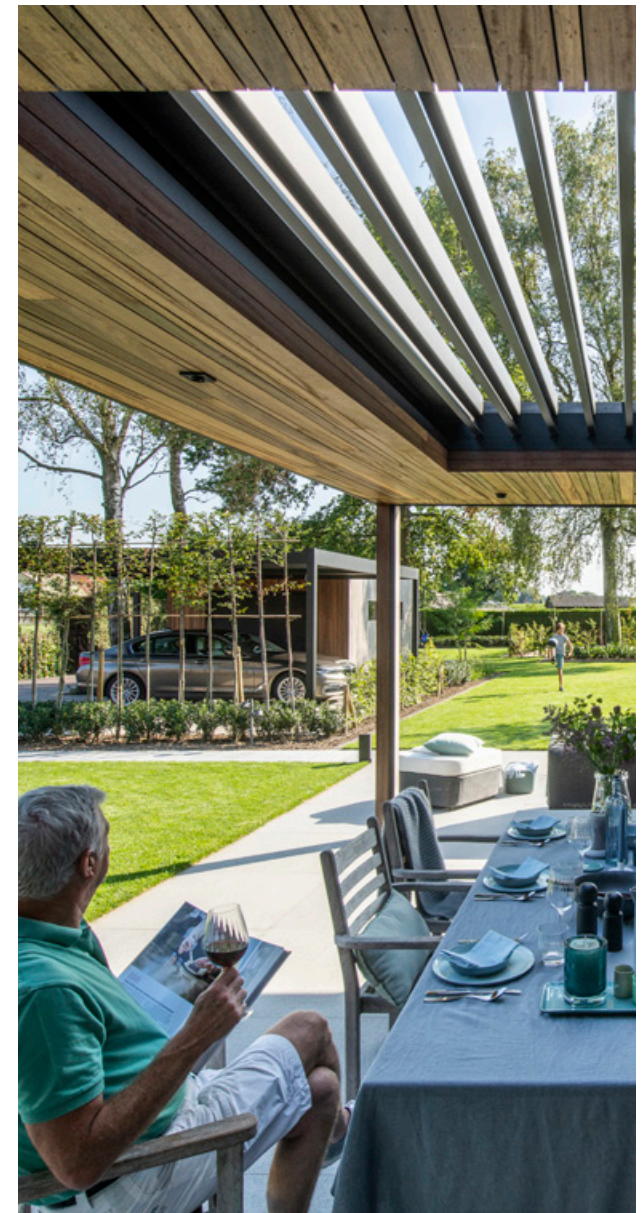

# CERTIFICATES & TESTING

## Water tests

Water resistance and water drainage are tested using a spray installation that mimics rain. For example, we check the flow rate that our patio covers can drain and how this drainage can be optimised.

Aero can drain an amount of water equivalent to a rain shower with an intensity of 4 23/32" that last up to two minutes maximum. This type of rainfall occurs on average once every ten years in Belgium [see Belgian rain statistics: NBN B 52-011 standard].

## Load-bearing capacity

Patio covers are subjected to various external forces [e.g. snow]. The load-bearing capacity of our patio covers is determined using static strength calculations carried out by our engineers and validated through internal tests. The basic principle is that the structure is allowed to bend by 1/200<sup>th</sup> of its longest dimension without any permanent deformation.

The load-bearing capacity of Aero is dependent on the basic structure and the surface area. The diagram indicates the load-bearing capacity of our patio covers depending on their span and pivot dimensions.

Load-bearing capacity against collapse [236" x 157"]	
Aero, Aero Skye & Aero Canvas	20,48psf



## CE – DoP documents

- CE / UKCA / DoC / DoP / ETA

## Certificates

- REACH / seaside/coastal powder coating guarantee
- RoHS / AluEco
- VMRG sun protection

## Declarations

- Declaration of material codes
- Declaration of powder coating
- Declaration of anodisation layer thickness
- Declaration of glass properties
- Declaration of fire resistance / reaction
- Declaration of endurance cycles
- Declaration of asbestos
- Declaration of UV resistance / gtot + others

## Test reports – calculations

- Environmental statement [recycled aluminium]
- Anchoring requirements
- Wind [load] testing / verification certificate

Wind guarantee of roof with blades closed	up to 74mph / HC1 [Hurricane Cat 1]
Fixscreen wind guarantee when closed	N/A
Max. wind speed for roof or Fixscreen operation	up to 31mph
Water drainage flow	0.53 GPM [gallons per minute]
Load-bearing capacity	20,48psf

# DETERMINATION OF OCCURRING FORCES

For example: Aero measuring 6000 × 4000 mm (236" × 157")

Blade load (net weight + snow load) = 1.24 kN/m<sup>2</sup>.

For a roof surface area of 6000 × 4000 mm, that makes: 6 × 4 × 1.24 = 27.76 kN.

The net weight of the frame, consisting of two span and two pivot profiles, is:  
 2 × [5.714 kg/m\* × 6 + 3.910 kg/m\*\* × 4] = 99.85 kg = 0.979 kN\*\*\*.

Total load on 6 × 4 m Aero = 27.76 + 0.979 = 28.74 kN.

Total load per bolt = 28.74 kN / number of bolts.

\* weight of pivot profile/m

\*\* weight of span profile/m

\*\*\* 1 kg = 9.80665 N

<b>Bolt grades</b>	4.6	5.6	6.8	8.8	10.9
<b>Flow limit</b>	240	300	480	640	900
<b>Tensile strength</b>	400	500	600	800	1000
<b>Sliding factor</b>	0.6	0.6	0.5	0.6	0.5

	Hole diameter d0 (mm)	Shank cross section (mm <sup>2</sup> )	Span cross section (mm <sup>2</sup> )
<b>M12</b>	13	113	84.3
<b>M16</b>	18	201	157
<b>M20</b>	22	314	245
<b>M24</b>	26	452	352

**Bolt shear load**

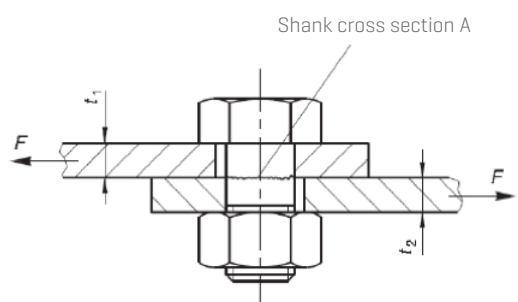

$$F_{v,Rd} = \frac{[\alpha_v \cdot f_{u,b} \cdot A]}{\gamma_{m2}}$$

$F_{v,Rd}$  = maximum permissible shear force  
 $\alpha_v = 0.6$  → safety factor for shearing  
 $f_{u,b}$  = nominal tensile strength  
 $A$  = span cross-section  
 $\gamma_{m2}$  = partial safety factor = 1.25

Example: M12 grade 4.6 bolt → maximum shear force on bolt = [0.6 \* 400 \* 84.3] / 1.25 → 16.19 kN.

# CONFIGURATION

## Type

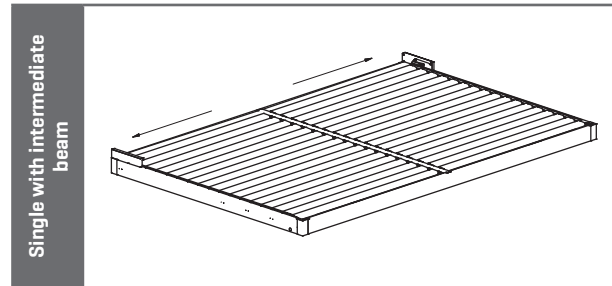
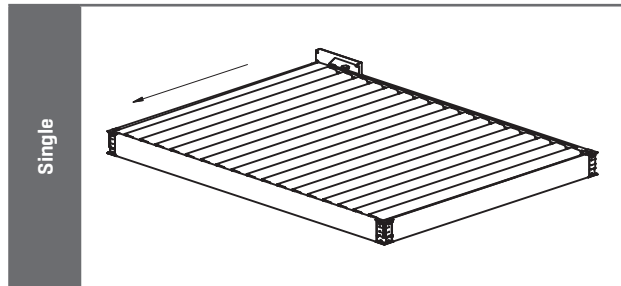

## Construction method

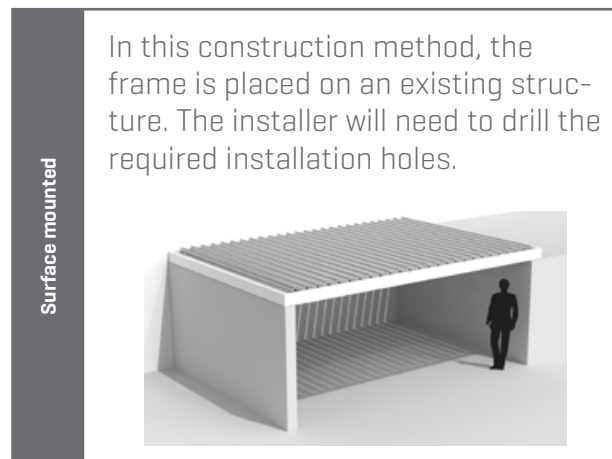
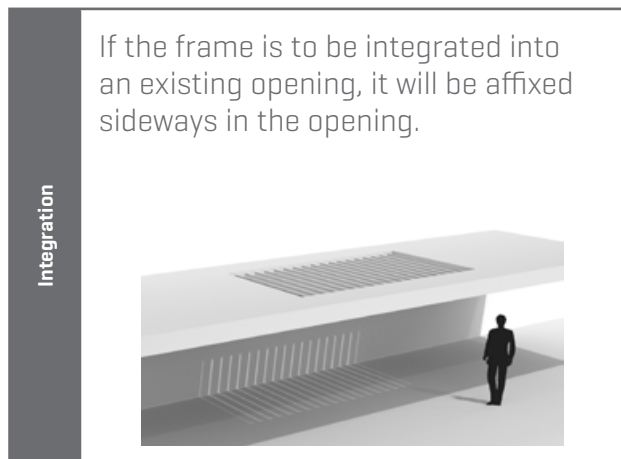



## Dimensions

The **span** length is always to be specified with **made to measure** precision.

You can then specify a **pivot** length based on either the **blade pitch** or with **made to measure** precision.

Depending on whether you go by the blade pitch or specify a precise inches length, there is an important aesthetic difference for the pivot. If the pivot is produced with inches precision, we will use the Camargue's residual blade. If you specify a pivot dimension based on the blade pitch, there will not be an extra residual blade next to the fixed blade in which the controls are located.

The drawings below provide further clarification on this difference.

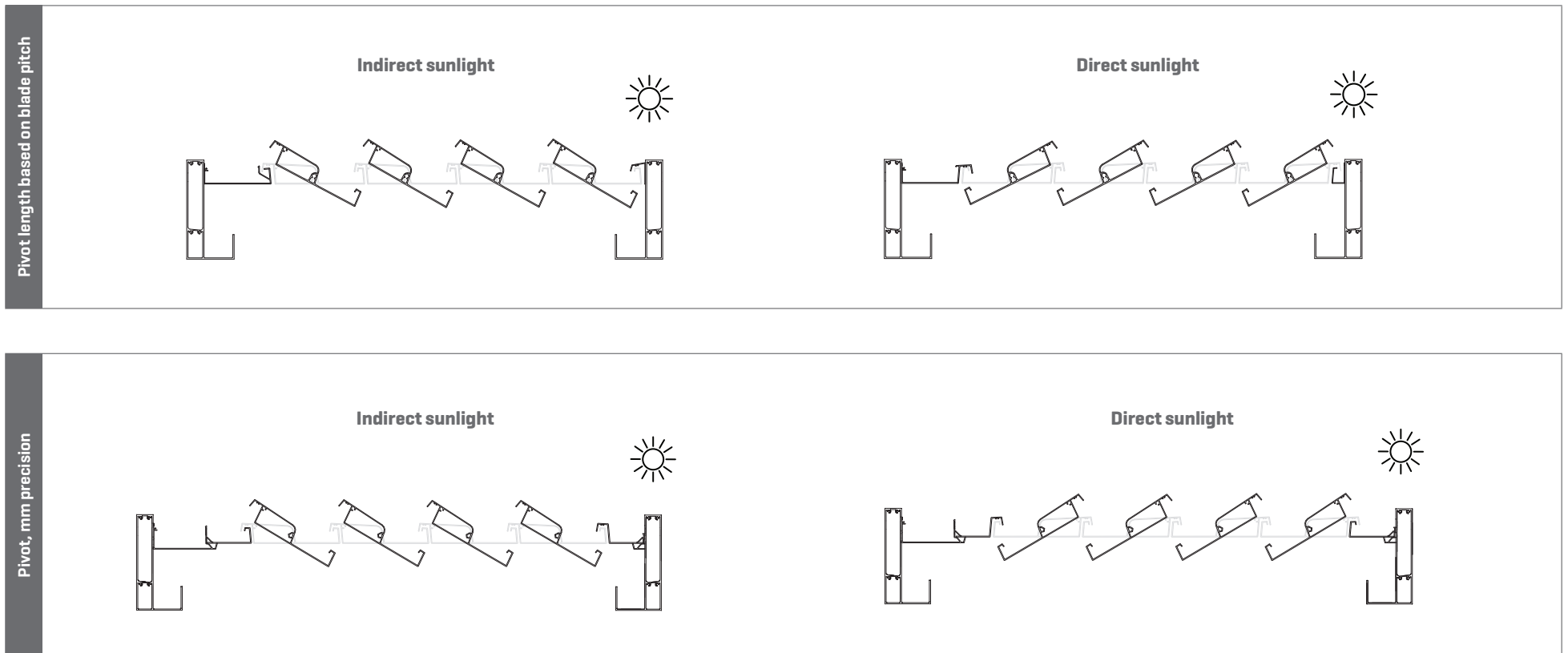

## Outer corner finishing cover

When ordering, please specify the construction situation for each span and pivot side. Depending on which one of the two construction situations you opt for, there is also a significant difference in terms of the finishing cover supplied for the outer corner.

- Surface mounted: includes finishing cover for the side in question
- Integrated: no finishing cover for the side in question

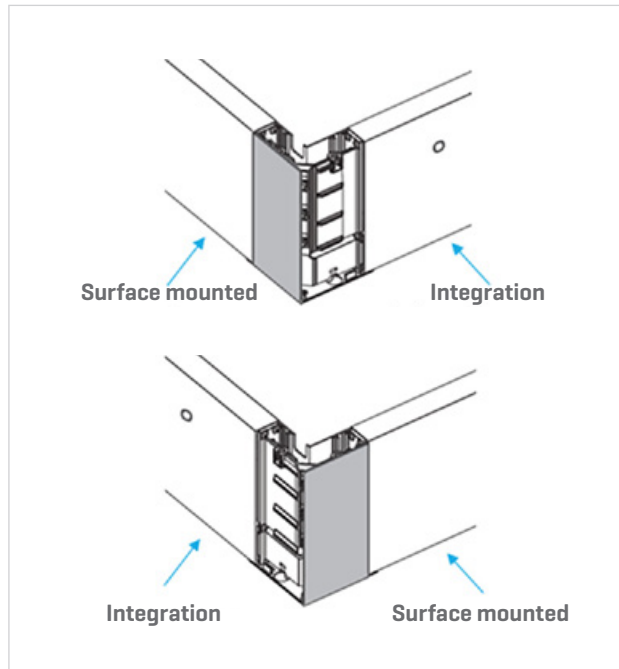

## Bottom finishing cover

The bottom finishing cover protrudes fraction of an inch from the underside of the structure. If you place Aero on top of another structure, you have the option of doing so without the bottom finishing cover. That way, the bottom of the profiles fit nicely against the support structure.

In the **example to the side**, the bottom finishing cover cannot be omitted because the bottoms of the profiles are also partially visible. However, this does not result in a perfect connection.

If the bottom of the frame profiles is to be finished with another material and will ultimately no longer be visible, there is no need to place a finishing cover on the bottom corners.

If you have a situation where you wish to install the outer corner cover, but do not have a bottom corner cover, you must first install an **additional bracket**. This will allow you to install the outer corner cover without the bottom corner cover.

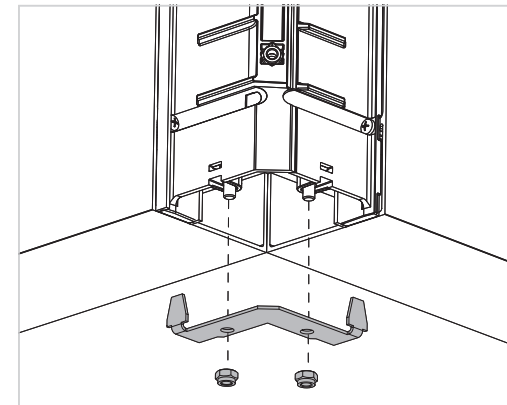
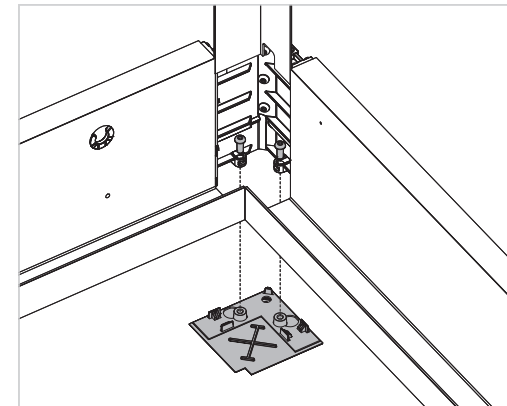
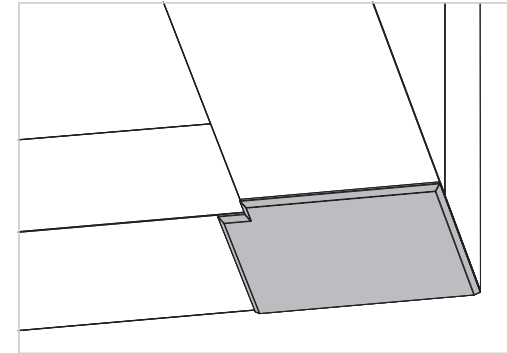

# Profiles

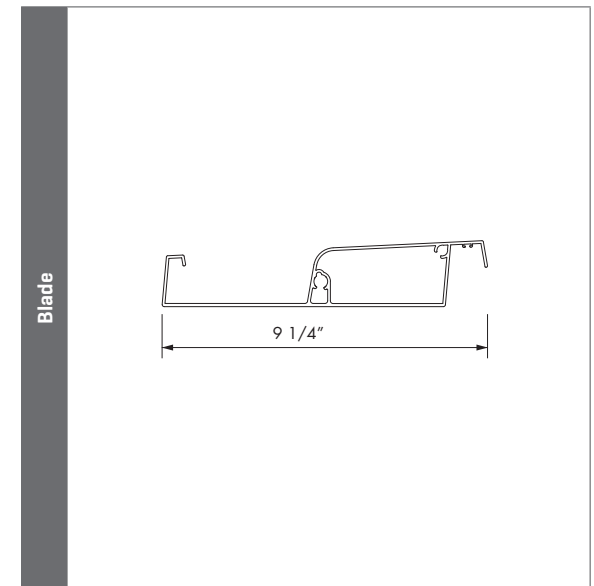
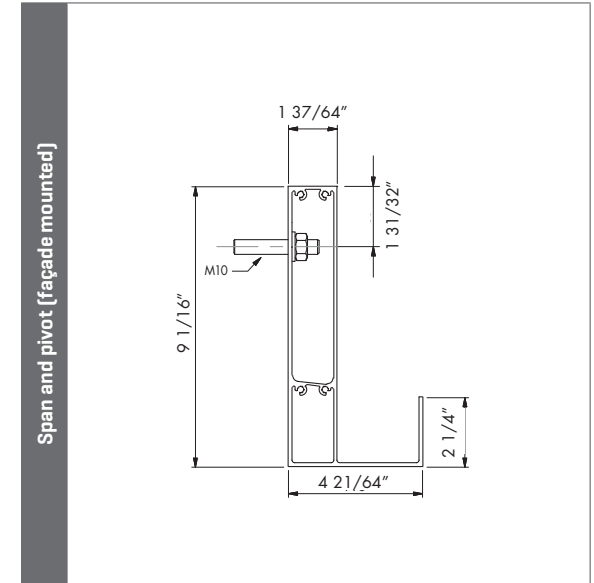
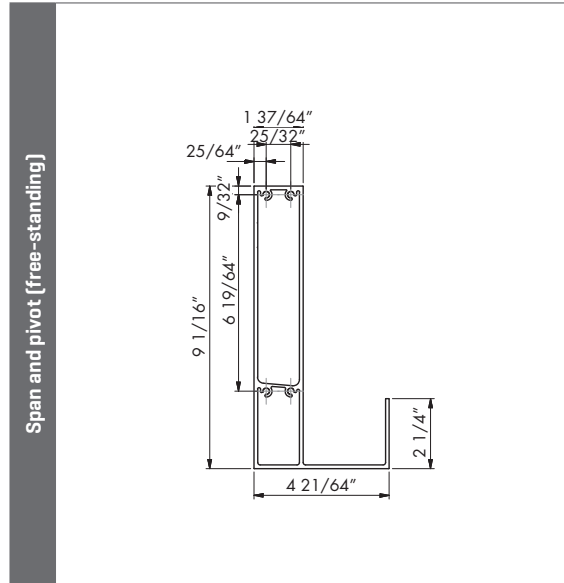
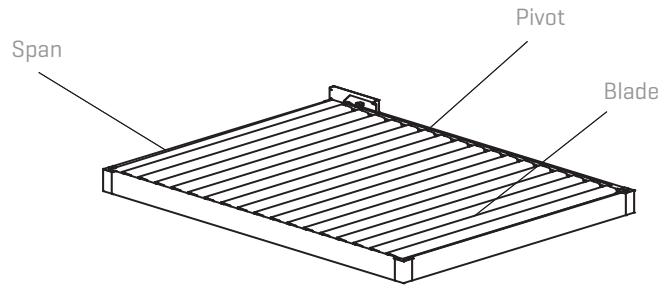

## Motor control

The blades are driven by a linear motor. This motor is visible on the Aero structure. It is controlled via RTS, an external Somfy control platform that is implemented in the motor control unit.

The motor sits on top of the frame and is covered with a powder coated aluminium cover in the colour of the structure.

As standard, the motor is always on the high side of the blades. Water must be drained away from the motor. An exception to this rule can be made in certain cases.

**Please note:** water drainage must always be fitted on the low pivot side.

The motor position is fixed in a joined cover. Both motors are always on the outer pivot beams.

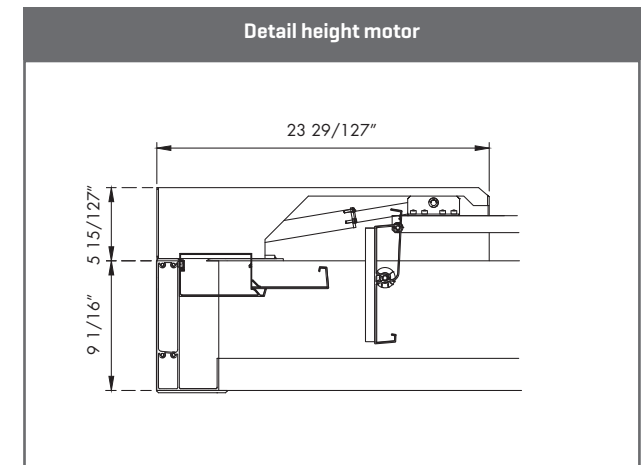
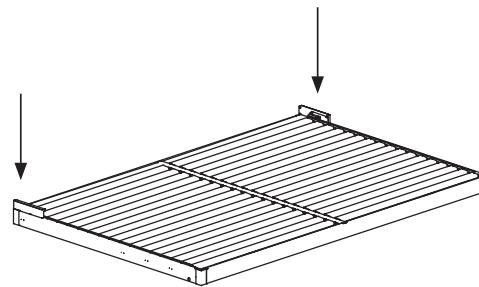
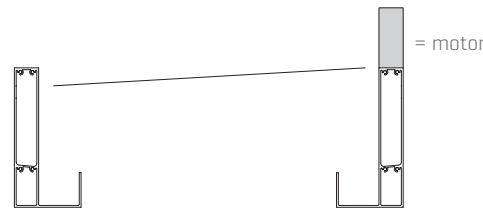
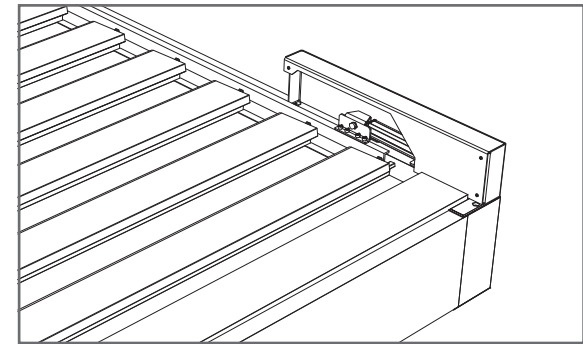
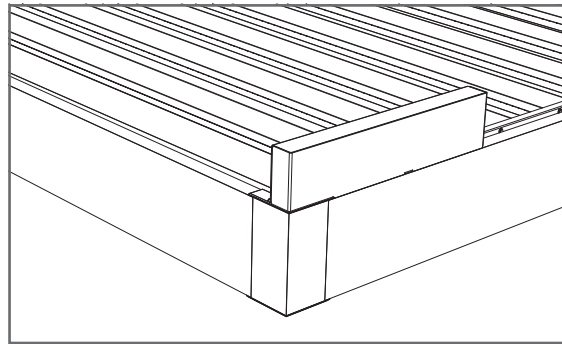

## Power supply

Check to see where the motor will be installed. Arrange a power cable closest to the motor.

## Blade orientation

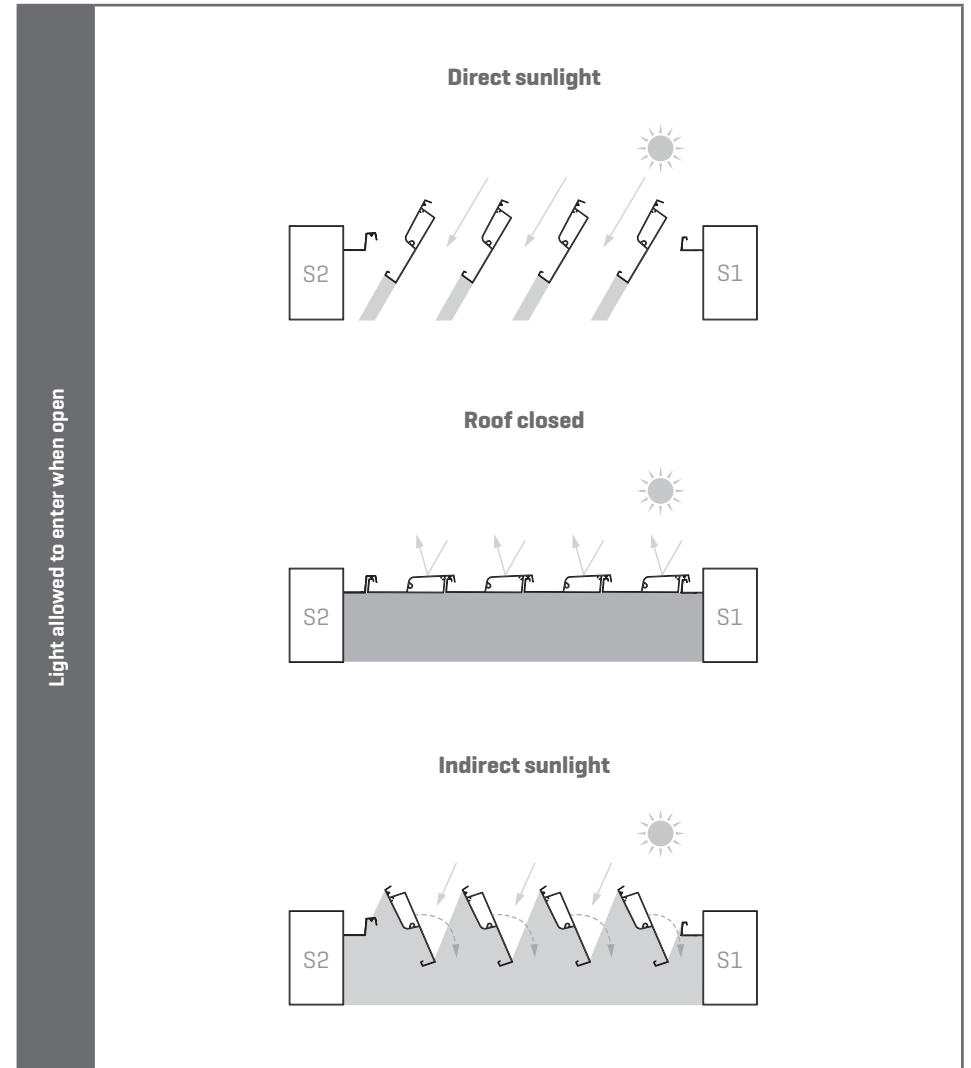
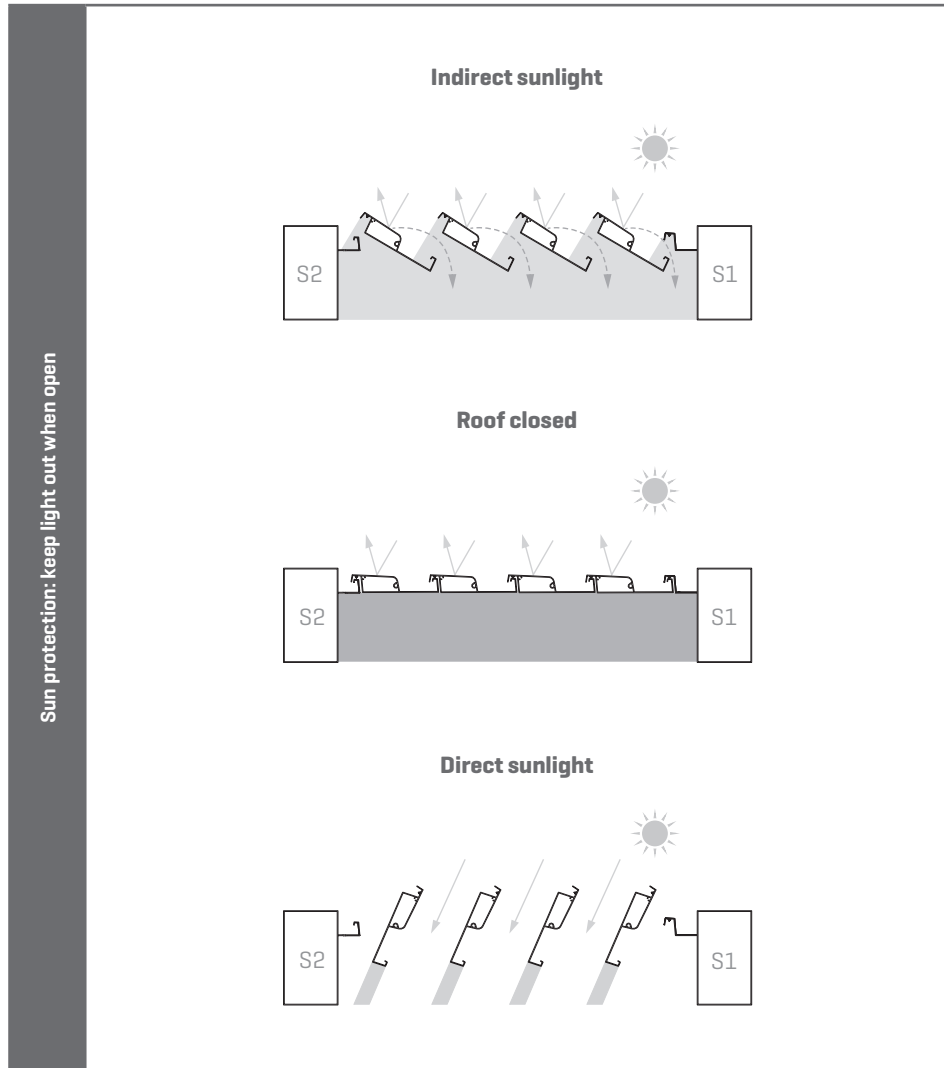

## Installation

For Aero, you must select the construction situation for each side (span [S] – pivot [P]) when ordering. You can choose between surface mounted or integrated. Side fixation holes will be applied if you select **'integrated'**. **No** side fixation holes will be applied if you select **'surface mounted'**.

The number and position of fixation holes on each side varies according to the size of the structure. You can find out the position of the holes using a calculation tool (Excel file), so you can adapt the roof structure beforehand.

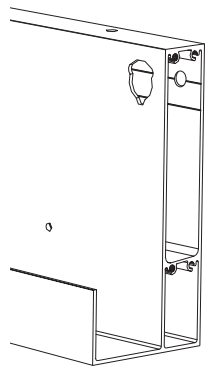

Fixation hole when choosing 'integrated'

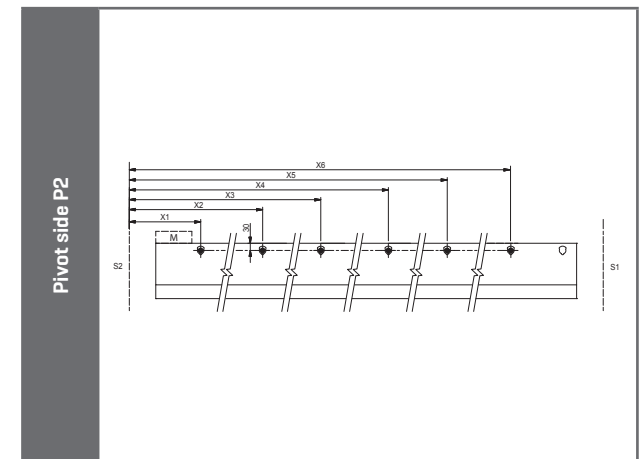
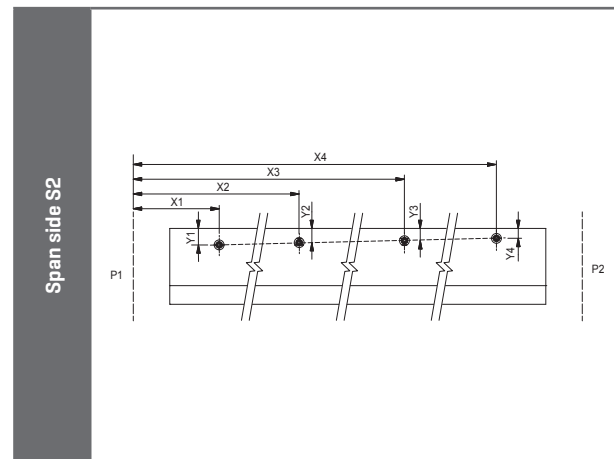
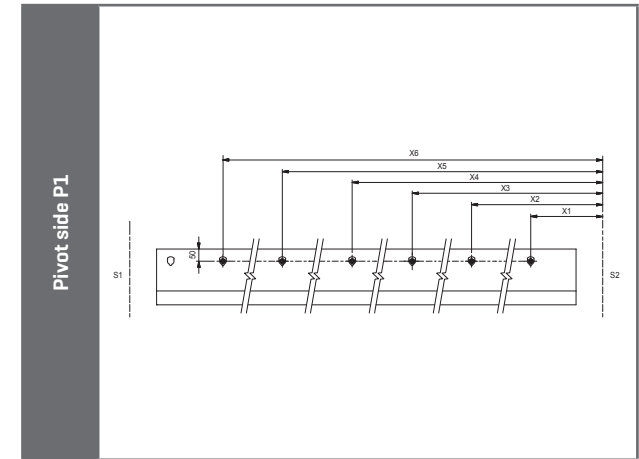
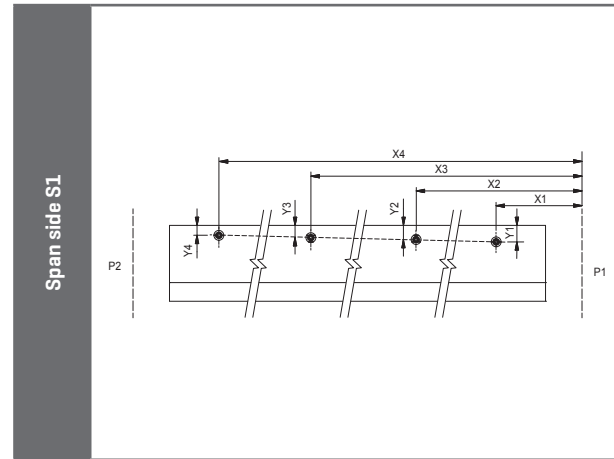

- Pivot side: the fixation holes are level with the blade axles, meaning they will not be visible at a later stage.
- Span side: the fixation holes are level with the fixed blade, meaning they will not be visible at a later stage.

The fixation holes in the structure are 12 mm [15/32"] in diameter, allowing an M10 bolt can be threaded through.

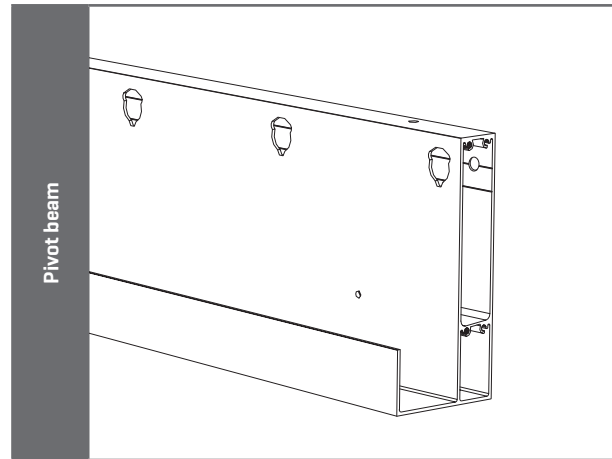

Number of fixation holes on pivot side	
0 - 2000 [0"-78"]	2 x M10
2001 - 3000 [79"-118"]	3 x M10
3001 - 4000 [119"-157"]	4 x M10
4001 - 5000 [158"-196"]	5 x M10
5001 - 6055 [197"-238"]	6 x M10

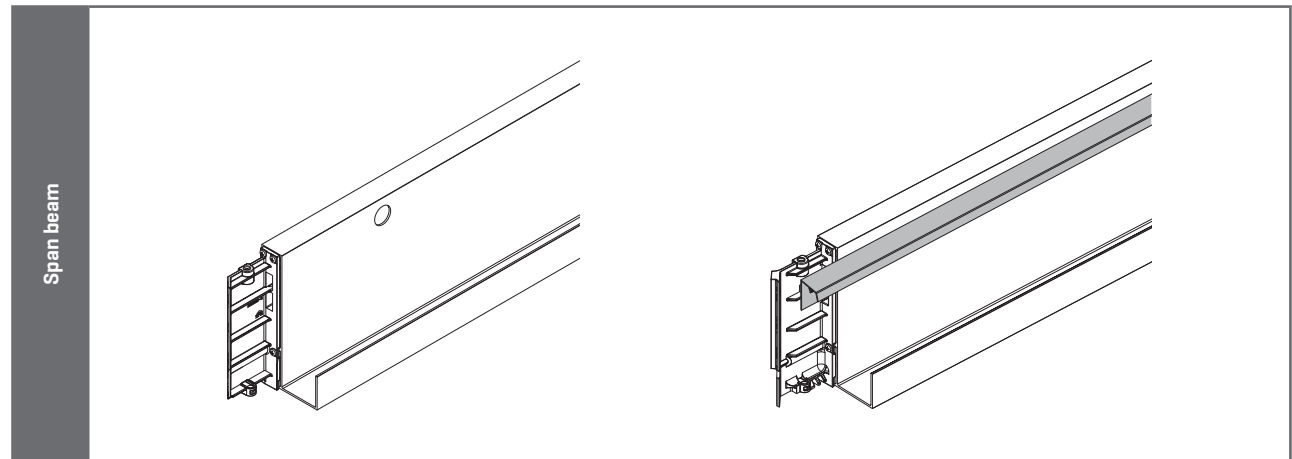

## Water drainage

### Water drainage direction

The blades are double-walled, with part serving as a gutter. The blades sit at an angle of 25/32". From the wide blade gutter, water will mainly drain to the lowest side and flow into the structure's integrated gutters. The structure is fitted with an integrated gutter all around.

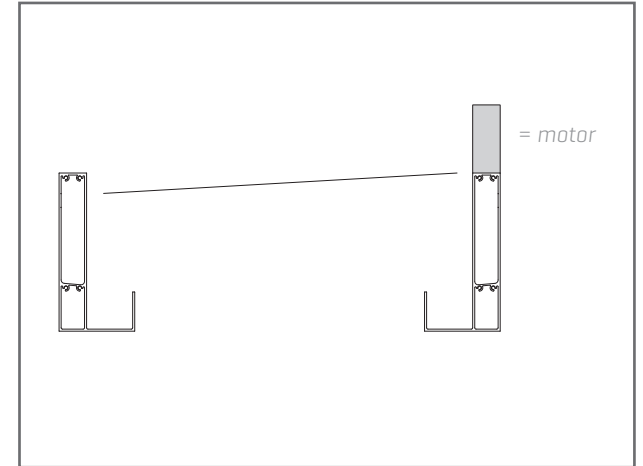
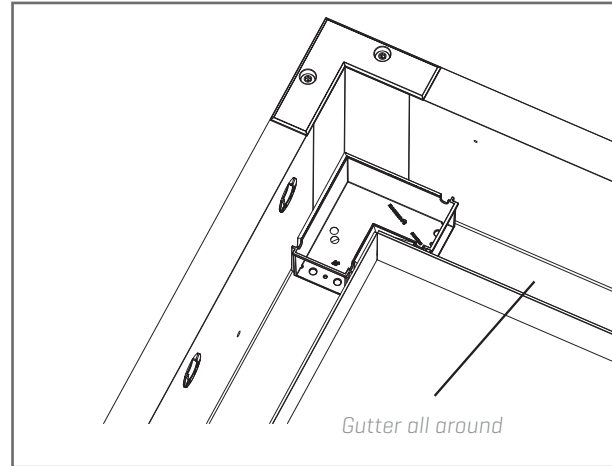
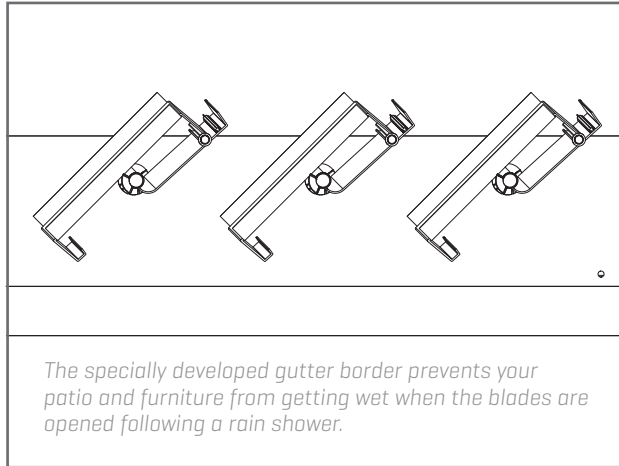

The water drainage direction of the blades is away from the motor side. Upon request, however, this direction can also be towards the motor side. This will result in a different driving profile being fitted.

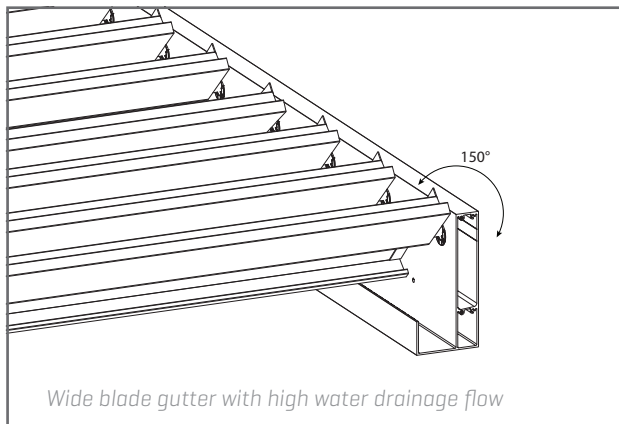



## Water drainage types

Water drainage can occur in three ways:

- Through the gutter
- In the corner
- Sideways

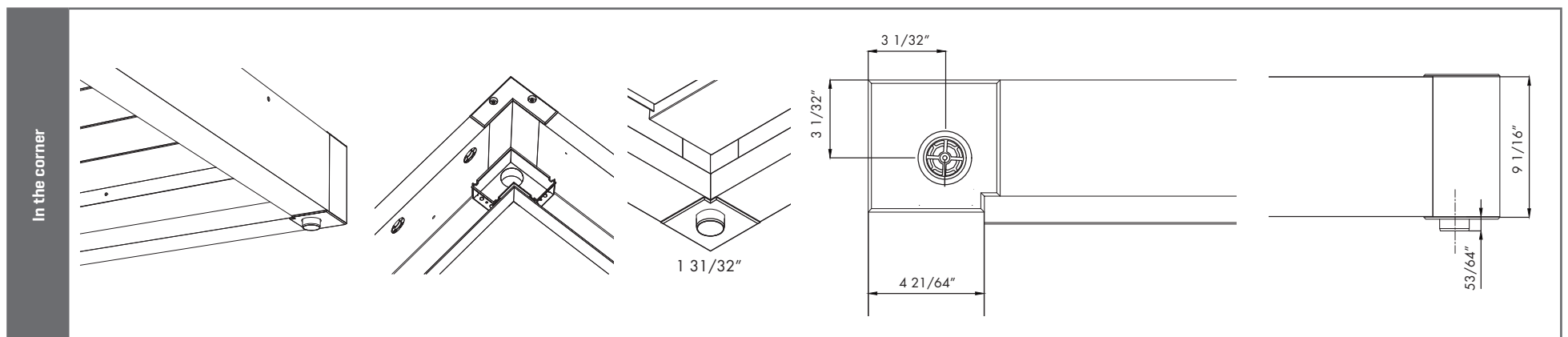
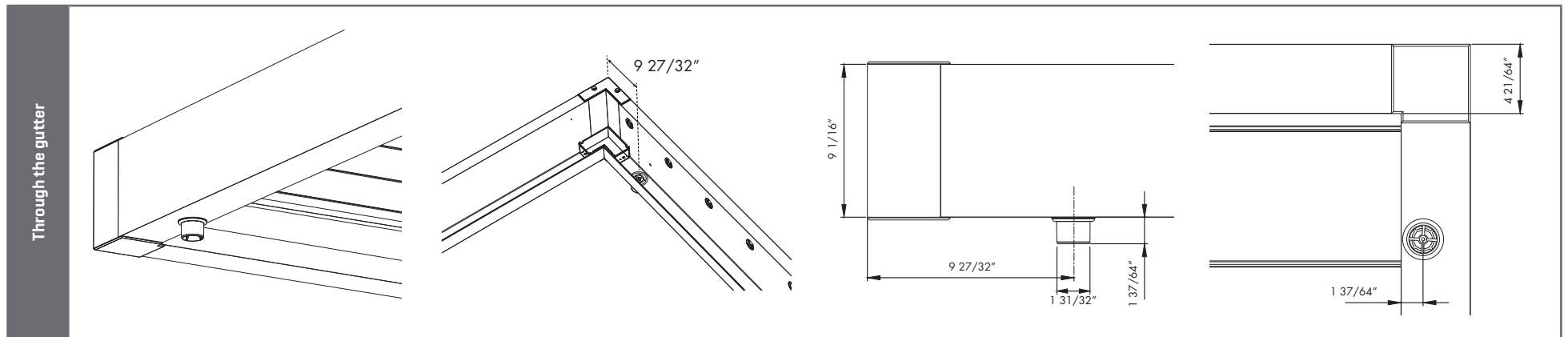

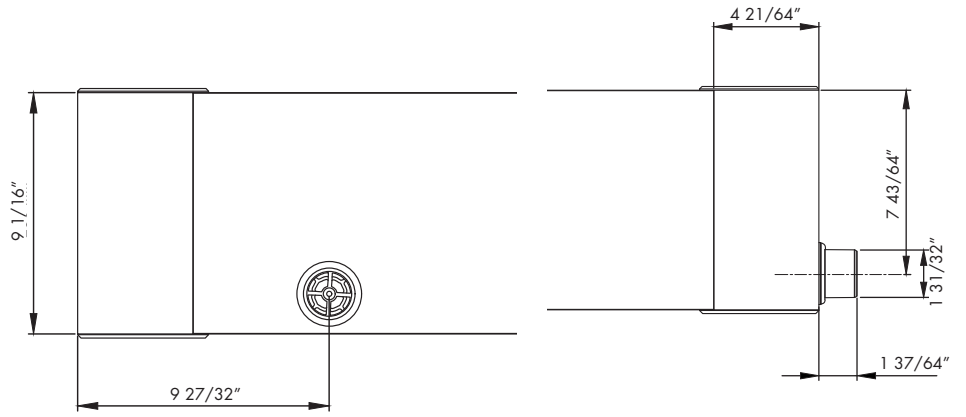
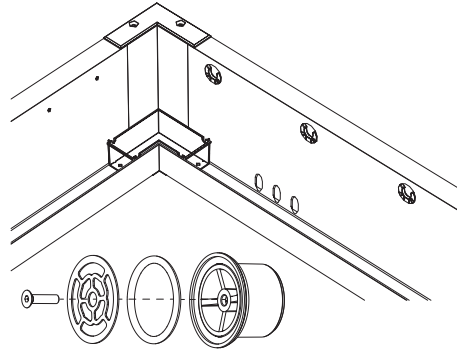
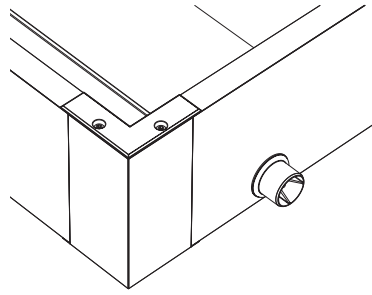

## Number of water drainage points

### Surface area < 172sqft

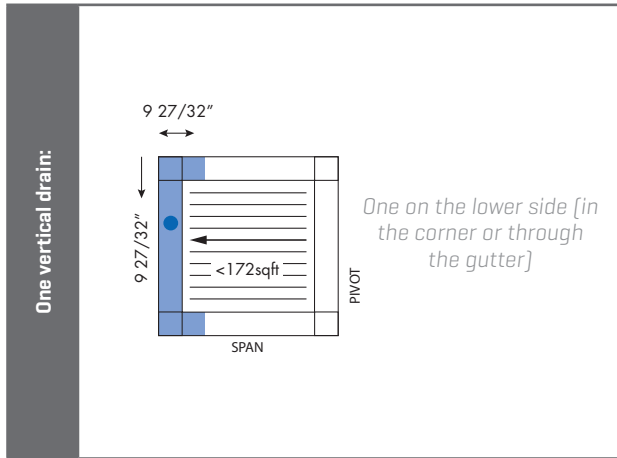

### Surface area > 172sqft

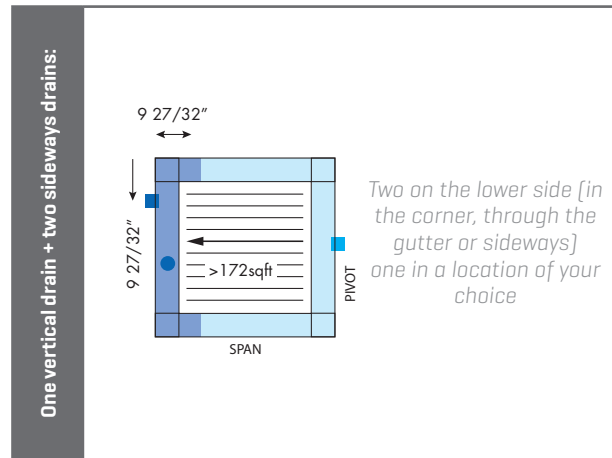
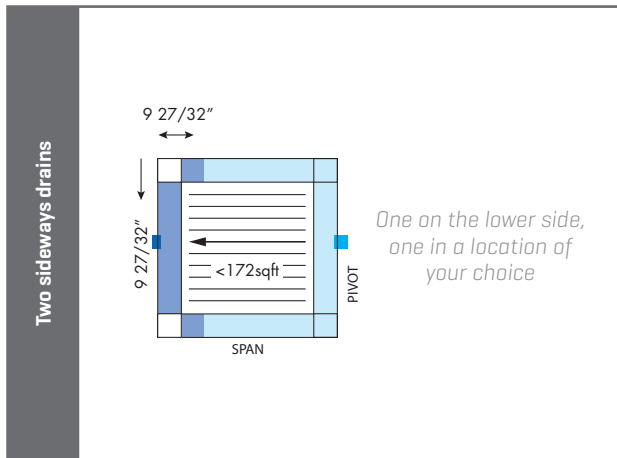
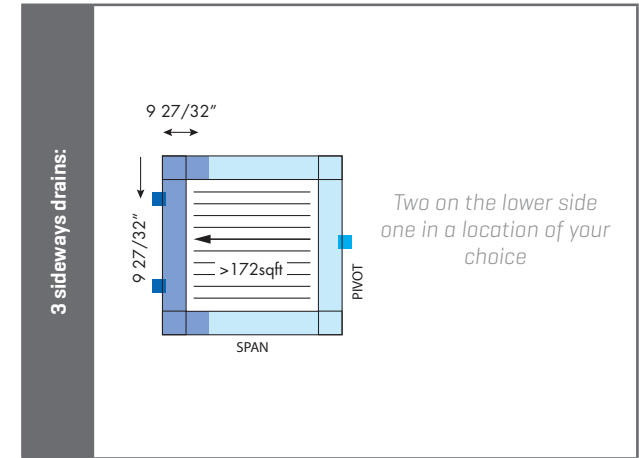
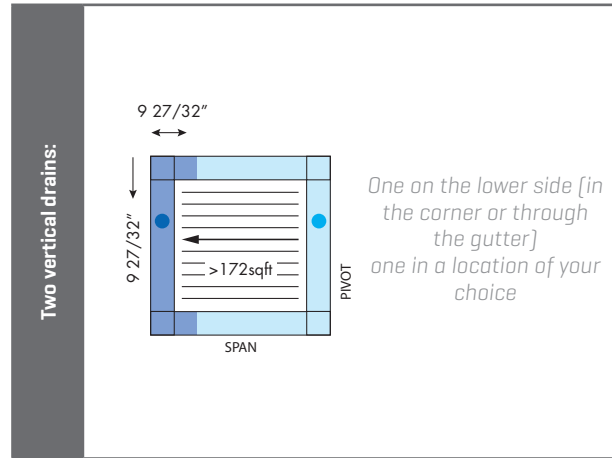

# INSTALLATION

## Installation

Integrated into a roof overhang

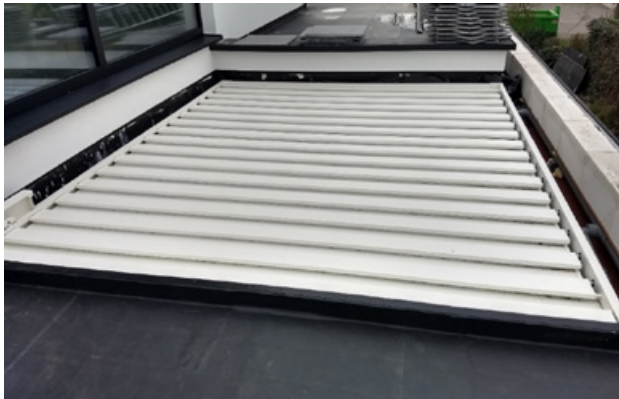

## Drainage connection

The sideways drain and the other drains can be connected to standard PVC pipes.



# Finish

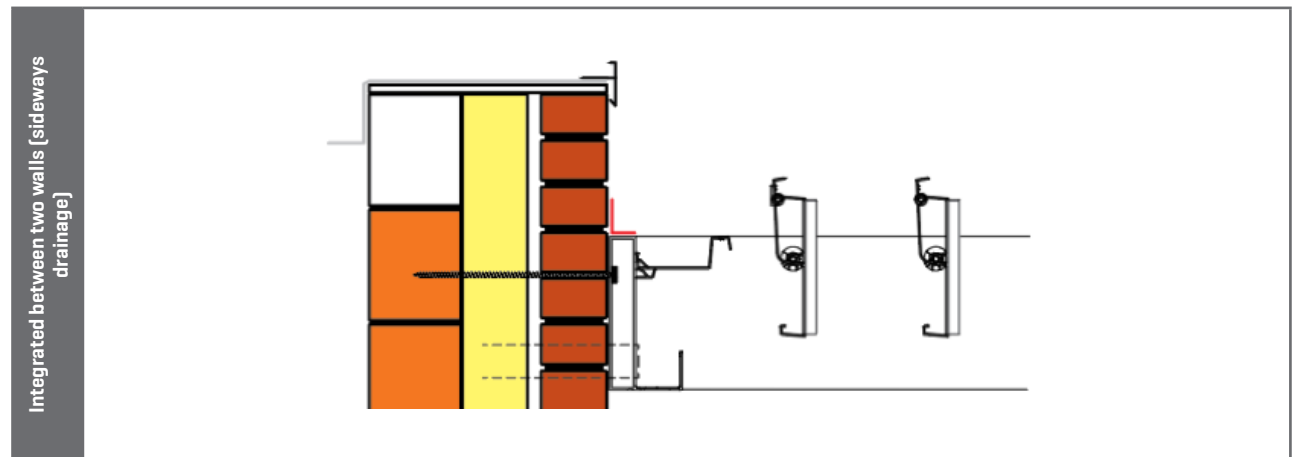
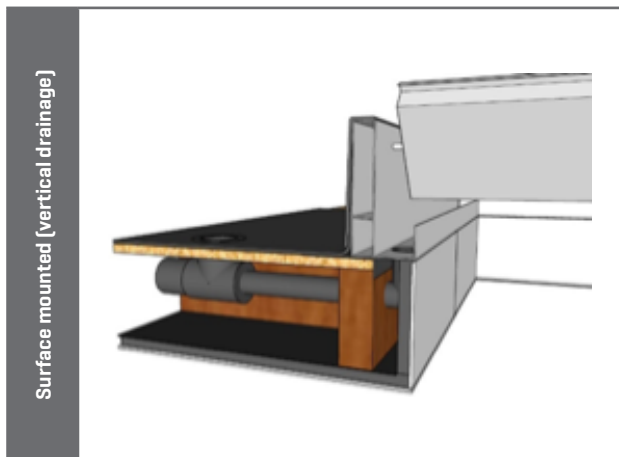
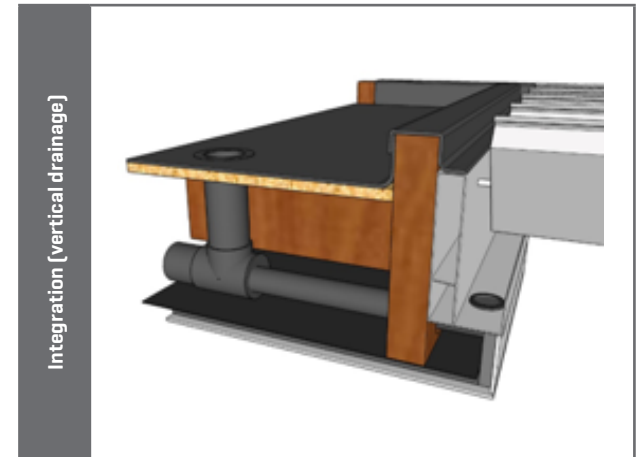
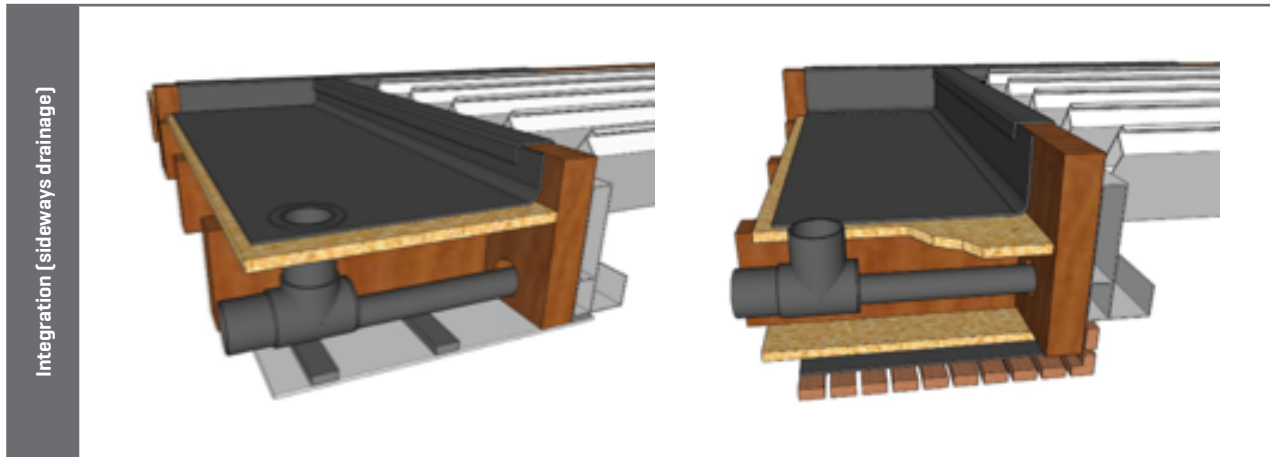

## Sealing

### Connection against a brick façade

Using waterproof flashing tape  
[available in different colours].



### Integrated into a wooden roof structure

EPDM must always be fitted up to the Aero  
[span + pivot] frame beams.



### On the motor side, EPDM or flashing tape must be affixed until it reaches under the motor/cover

The motor cover must be installed as the very  
last element.



# OTHER TOOLS

Want to find out more? Visit the Professional Portal on our website ([www.renson.eu](http://www.renson.eu)) to access the following tools.

- Technical drawings
- Training documents
- Installation manual
- User manual
- [Digital photo book & social media](#)
- ...

