



HEAVY DUTY ADJUSTABLE SUPPORT BRACKETS



Vertical Arms

- Available in Black (909-58) or White (933-58)
- Junction Blocks provided to use multiple Vertical Arms in succession
- Horizontal Arms can span 2 Vertical Arms for maximum adjustability
- Finishing Caps provided

ADJVA



Left vertical arm without finishing plugs

Right vertical arm with finishing plugs

Formica color matches:

- Black 909-58
- White 933-58

Horizontal Arms

- Available in Black (909-58) or White (933-58)
- Available with a 12" or an 18" Arm
- 12" arm rated at 2400 lbs/pair
- 18" arm rated at 1800 lbs/pair

Heavy Duty Adjustable Support Brackets Mounting Hardware Included

Bracket Size	Pcs/Wgt/Box*	Load to Deformation (lbf)
ADJVA	2 pc/5 lbs	
ADJHA12	2 pc/6 lbs	2400/pr
ADJHA18	2 pc/7 lbs	1800/pr

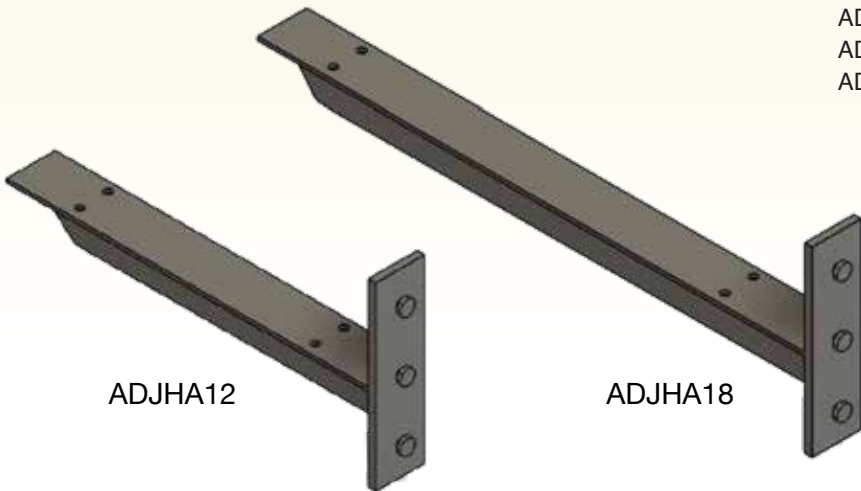

ADJHA12

ADJHA18



A&M HARDWARE, INC.

Call To Order (888) 647-0200

1165 Strickler Road, Mount Joy, PA 17552 | Fax: (717) 653-5874

www.AandMhardware.com