

STACBOND

Technical catalogue 2024

Specifications and assembly systems

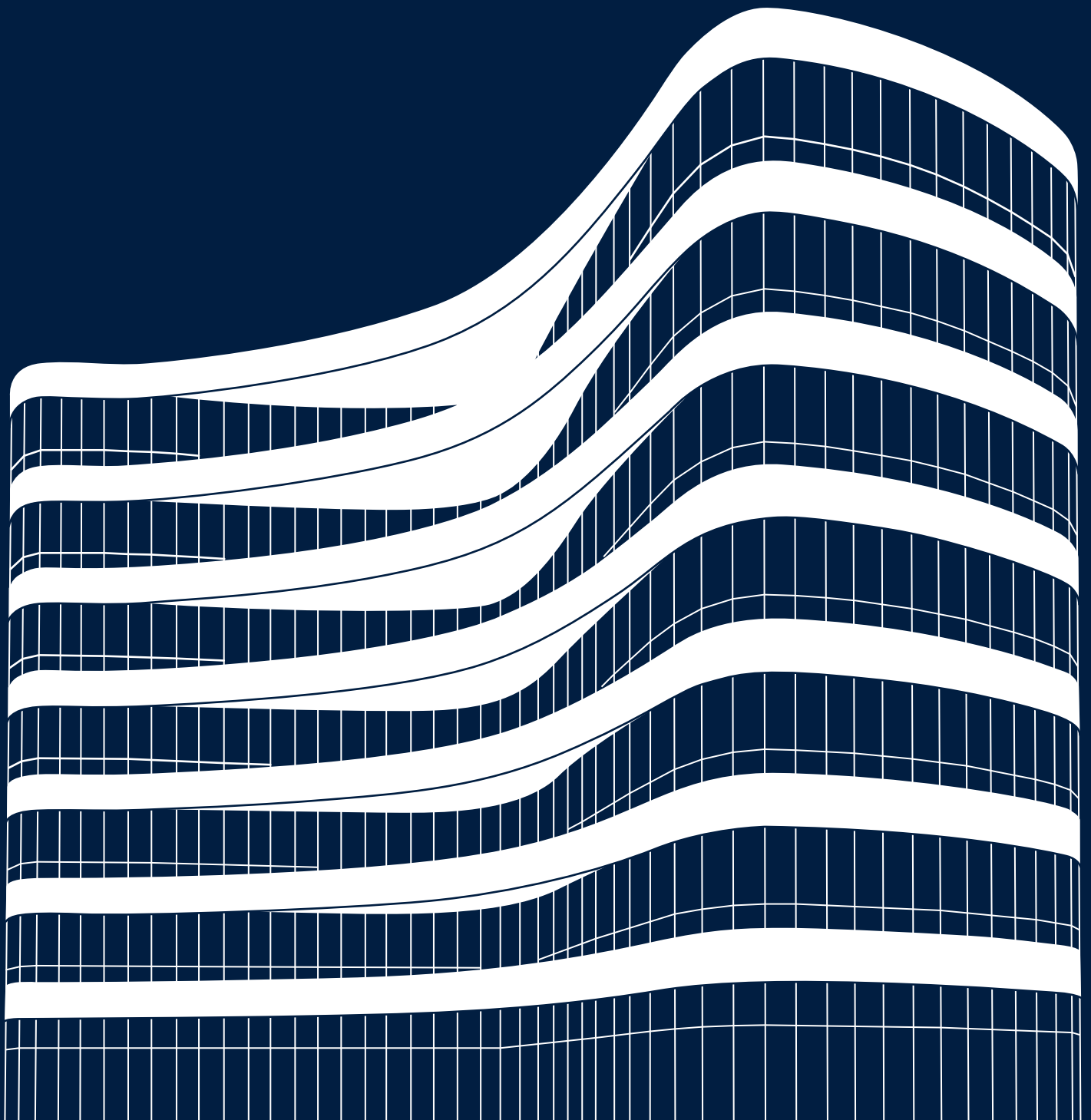

more than you see

STACBOND

Technical catalogue 2024

Specifications and assembly systems

STACBOND COMPOSITE PANEL	06
<hr/>	
ASSEMBLY SYSTEMS	21
<hr/>	
STB-T-CH HANGER SYSTEM	25
<hr/>	
STB-T-CH-PRO® HANGER SYSTEM	39
<hr/>	
STB-T-SZ MALE - FEMALE SYSTEM	51
<hr/>	
STB-T-SZ-PRO® MALE - FEMALE SYSTEM	63
<hr/>	
STB-T-REM RIVETED SYSTEM	77
<hr/>	
STB-T-PEG GLUED SYSTEM	87
<hr/>	
STB-CH HANGER SYSTEM	95
<hr/>	
STB-SZ MALE - FEMALE SYSTEM	105
<hr/>	
STB-REM RIVETED SYSTEM	115
<hr/>	
STB-PEG GLUED SYSTEM	125
<hr/>	
ACCESSORIES STACBOND	131
<hr/>	
PROCESSING TOOLS STACBOND	147
<hr/>	

STACBOND

Composite panel





STACBOND COMPOSITE PANEL

CHARACTERISTICS

The **STACBOND** composite panel is a product consisting of two aluminium sheets and an inner core with mineral fillers. It has excellent mechanical properties, providing bending stiffness with a reduced weight, a flat surface, durability and ease of maintenance.

They are the ideal solution in all fields of architecture: homes, public buildings, offices, business and industry. That's not to mention their use in promoting a corporate image in, for example, supermarkets, car dealerships, banks and petrol stations. They also offer solutions for the design, transport and industrial sectors.

In its manufacturing standard this product consists of an outer sheet of aluminium alloy 5005 and an inner sheet of alloy 3005/3105.

Two different core materials are available in terms of mineral content (incombustible or fire-retardant), which in accordance with standard UNE 130501-1:2007 are class A2-s1 d0 (**STACBOND A2**) and class B-s1, d0 (**STACBOND FR**).

This is lacquered with the highest quality PVDF 70/30 (polyvinylidene fluoride) which provides excellent resistance to ageing and the highest protection against UV rays, as well as having excellent behaviour when machined or formed.

STACBOND offers a full range of colours, shines, textures and natural finishes. Also, they can be supplied in any RAL/PANTONE/NCS colour – please enquire for details.

The **STACBOND** composite panel is available in various standard dimensions of up to 2.000 mm width. Other dimensions can be supplied under request.

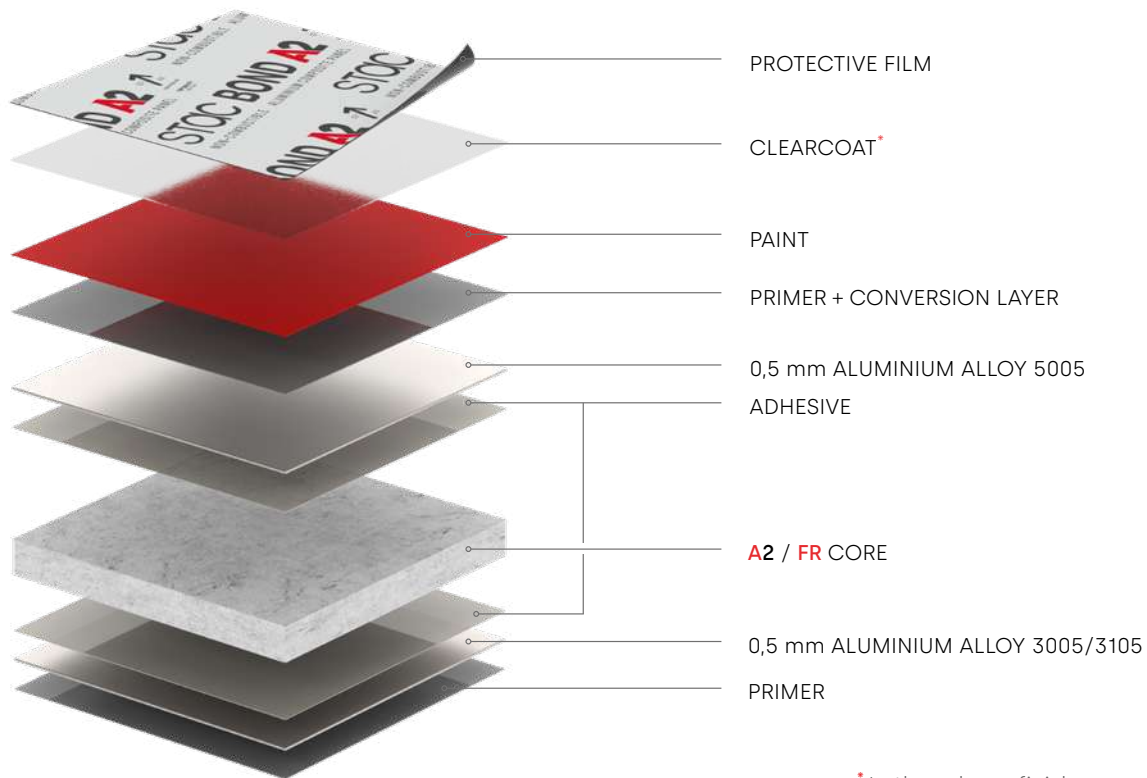

* In three-layer finishes or on request.

All RAL colours possible

A2, FR and PE cores

High resistance to UV rays

Excellent weight/surface value

Easily conformable

Rapid and simple assembly



Totally recyclable

PVDF 70/30 PAINT

Highest quality paint, used in most **STACBOND** regular finishes.

The 70/30 code indicates that the paint contains 70% polyvinylidene fluoride and 30% acrylic resin. This ratio is the optimal level to provide a high level of protection against UV rays and high ageing resistance. Mechanically, the paint has sufficient stretch to resist the forming of the panels without deterioration of the coating.

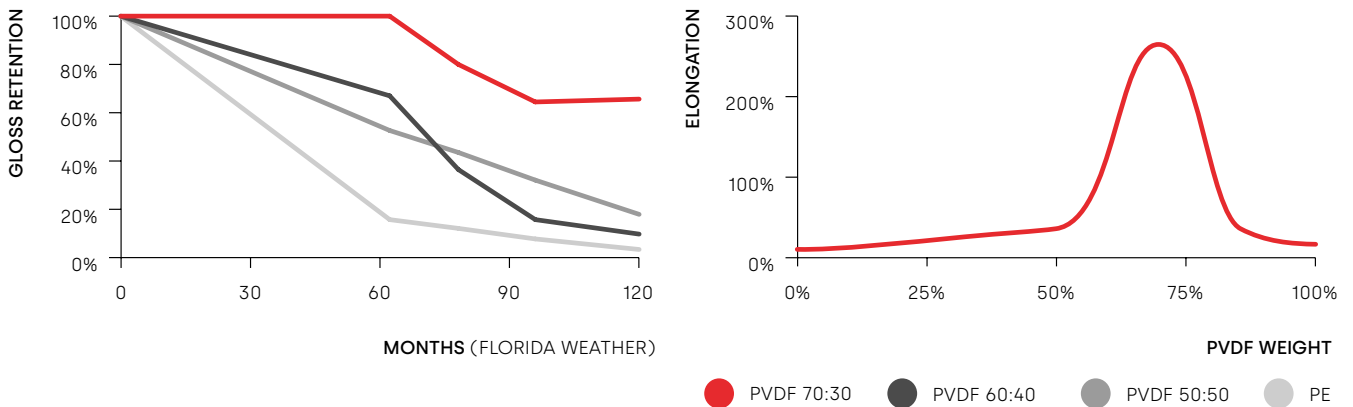
These finishes have a limited range of shine between 25 – 35%, measured at an angle of 60°.



FEVE (LUMIFLON)

FEVE is a type of coating with a very similar structure to PVDF but it is harder and less flexible. It allows a wider shine range.

HDPE (High durability polyester)

HDPE paint is a slightly lower performance finish than PVDF, but allows high gloss range and some special finishes such as textured surfaces.

INNER FACE PROTECTION PRIMER

The epoxy/epoxy-polyester primer is applied at 5 - 10 microns and protects the interior face of the STACBOND composite panel.

STACBOND COMPOSITE PANEL

OUR COMMITMENT TO THE PLANET



CERTIFIED QUALITY

The manufacture of the **STACBOND** composite panel follows a controlled process by means of rigorous internal tests and quality controls, in our own laboratories and externally through audits by the most prestigious construction institutes in all the countries where we are certified.

The granting of these certificates follows the European guideline of the **EAD GUIDE 090062-00-0404** for ventilated façades and allows us to conclude that our construction systems comply with the national regulations of each country.

INTEGRATED QUALITY AND ENVIRONMENT SYSTEM

STACBOND has an integrated quality and environmental system, based on the **UNE-EN ISO 9001** and **UNE-EN ISO 14001** standards. This is possible because the environmental management system (EMS) implemented in our facilities complies with the requirements of these regulations.

ENVIRONMENTAL PRODUCT DECLARATION

STACBOND A2 and **STACBOND FR** products have renewed the Environmental Product Declaration (EPD) for the **STACBOND** composite façade panel, according to EN ISO 14025:2010 and EN 15804:2012+A2:2019/AC:2021.

The scope of the certificate includes the life phase, raw material sourcing, transport, manufacturing, end-of-life and recycling phase of the product, deconstruction and demolition, transport, waste processing, disposal and reuse-recovery-recycling potential.

ZERO WASTE CERTIFICATE

STACBOND has a system for controlling and monitoring the waste generated in its production process, aimed at guaranteeing reuse, recycling, take-back and recovery, in order to reduce disposal to landfill as much as possible.

STACBOND has therefore been certified as zero waste in accordance with the requirements of the Bureau Veritas certification standard, where it has achieved an advanced level of commitment, certifying an alternative management to landfill of between 80% and 95%.

ENVIRONMENTAL CERTIFICATES









COUNTRY	RECOGNITION	BODY	STACBOND A2	STACBOND FR
INTERNATIONAL	EPD S-P-01289	Tecnalia R&I Guipúzcoa (Spain)	✓	✓
INTERNATIONAL	LEED 2014	USGBC	✓	✓



As part of our commitment to the environment, **STACBOND** does not use chromium in any of the pre-treatment or painting processes.

STACBOND COMPOSITE PANEL CERTIFICATION

SYSTEM CERTIFICATION

COUNTRY	RECOGNITION	BODY	SYSTEM							CORE		
			T-CH	T-CH-PRO®	T-SZ	T-SZ-PRO®	T-REM	CH	SZ	REM	A2	FR
EU	IETcc Madrid	ETE 15-0655 - EC Marking	✓	✓	✓	✓	✓	✓	✓	✓	✓	✓
SPAIN		DIT 553p/19	✓	✓	✓	✓	✓	✓	✓	✓	✓	✓
POLAND		ITB-KOT-2017/0043 wydanie 2	✓	—	✓	—	✓	✓	✓	✓	✓	✓
FRANCE	CSTB Paris	Avis Technique 2.2/13-1548-V4 ⁽¹⁾ Avis Technique 2.2/13-1549-V3 ⁽²⁾	✓	—	✓	—	✓	✓ ⁽²⁾	✓	✓ ⁽¹⁾	✓	✓
UNITED KINGDOM		BBA 13/5022	—	—	—	—	—	✓	✓	✓	✓	✓
ROMANIA		TPC	✓	—	✓	—	✓	✓	✓	✓	✓	✓
GERMANY		DIBt 75-1.10.3-809/1	✓	—	✓	—	✓	✓	✓	✓	✓	✓
SWITZERLAND		VKF - AEAI	✓	—	✓	—	✓	✓	✓	✓	✓	✓
MEXICO		VALUE AMEVEC	✓	—	✓	—	✓	✓	✓	✓	✓	✓
			WET SYSTEM*		DRY SYSTEM*		RAINSCREEN SYSTEM*					
USA		ICC - ESR	✓		✓		✓			—	✓	
CANADA		INTERTEK	✓		✓		✓			—	✓	

* Compatible certified systems not supplied by STAC.

✓ IN PROGRESS ✓ CERTIFIED

FIRE-RESISTANCE RATING

COUNTRY	REGULATION	STACBOND A2	STACBOND FR
		CLASSIFICATION	CLASSIFICATION
U.E.	UNE-EN 13501-1:2018	A2-s1, d0	B-s1, d0
POLAND	PN-B-02867:2013	NRO	NRO
USA	ASTM E84	A CLASS: SD:10 FS:0	A CLASS: SD:5 FS:0
	NFPA 285	PASS	PASS
CANADA	CAN/ULC-S102-18	—	A CLASS: SD: 0 FS: 0
	CAN/ULC-S134	—	PASS
HUNGARY	MSZ 14800-6:2020	PASS	—
ISRAEL	EN 13501-1	—	B-s1, d0
FRANCE	LEPIR II	PASS	

STACBOND 

Our commitment to the planet



STACBOND RECYCLING SERVICE

GIVING ALUMINIUM COMPOSITE PANELS A SECOND LIFE

At **STACBOND**, we promote the circular economy by recycling, separating and reusing aluminium composite panel components. Both the core and the aluminium are fed back into the production process, thus closing the life cycle of the product.

We have implemented the **STACBOND RECYCLING** programme, a waste material collection system to reduce the environmental footprint of our products as much as possible.

With this composite panel collection and recycling system, **we take advantage of the surplus material in the production and installation of panels in buildings and give a new opportunity to the raw materials we use**, avoiding unnecessary waste of resources.



STACBOND A2

Non-combustible ACP

STACBOND A2 is a non-combustible composite panel composed of two sheets of aluminium and a mineral core developed to comply with the most stringent fire-resistance classification rules.

Thanks to the panels' exceptional mechanical properties (high rigidity, excellent flatness, impact resistance, durability and ease of maintenance) and A2-s1, d0 fire-resistance classification (in accordance with UNE EN 13501-1:2007), they are the ideal cladding solution for tall buildings and high-occupancy buildings.

Compliance with the strictest fire-resistance classification requirements, including:

- ✓ UNE-EN 13501:2018 — **A2-s1, d0**
- ✓ LEPİR II — **PASS**
- ✓ PN-B-02867:2013 — **NRO**
- ✓ NFPA 285 — **PASS**
- ✓ ASTM E84 — **A CLASS**
- ✓ MSZ 14800-6 — **PASS**

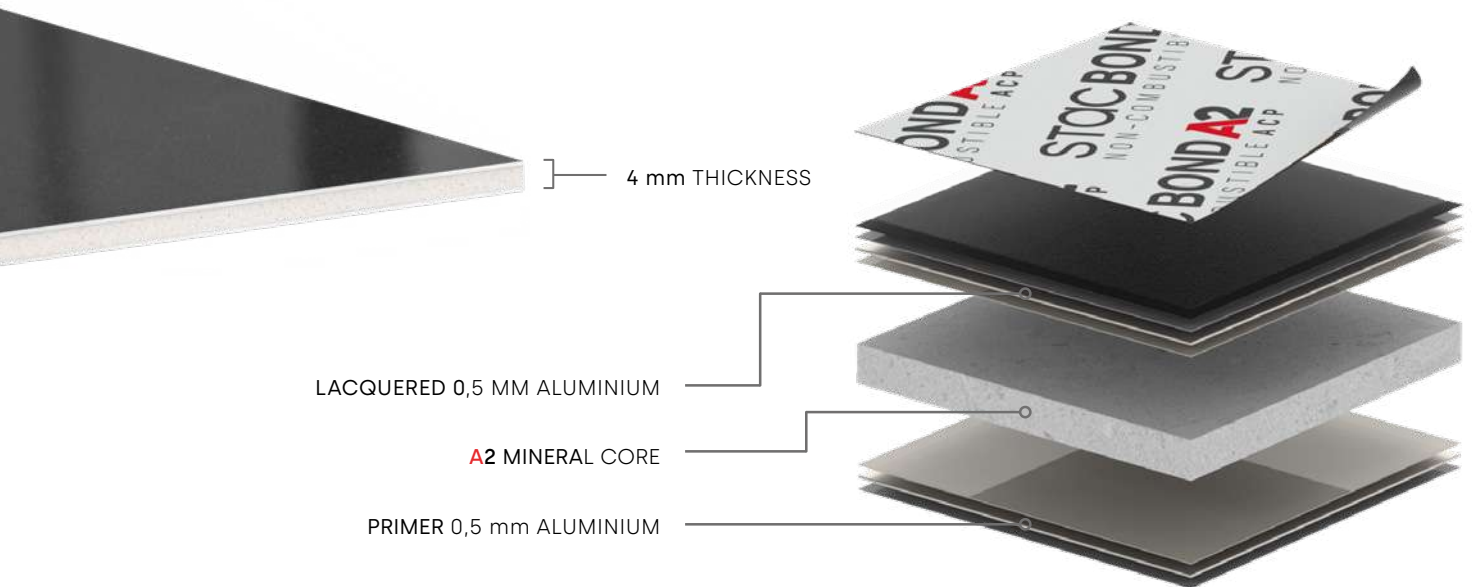

PANEL PHYSICAL SPECIFICATIONS	UNIT	VALUE	NORM
Total thickness	mm	4	
External painted face thickness	mm	0.50	
Internal painted face thickness	mm	0.50	
Panel weight	kg/m ²	9.30 ± 8%	
Visible face aluminium alloy		5005	
Hidden face aluminium alloy		3005 / 3105*	UNE EN 573-3

SHEET DIMENSIONS	UNIT	VALUE	
Width (min./max.)	mm	800 / 2000**	
Length (min./max.)	mm	2000 / 6000**	
Thickness tolerance	mm	- 0.15 / + 0.10	
Width tolerance	mm	- 0 / + 2	
Length tolerance	mm	- 0 / + 10	
Squareness (diagonal tolerance)	mm	± 3	
Protective film width tolerance	mm	0; -5	

TECHNICAL SPECIFICATIONS OF THE PANEL	UNIT	VALUE	NORM
Peeling	N/mm	≥ 3	ASTM D903 – 98 (2004)
Rigidity (EI)	kNcm ² /m	2400	DIN 53293
Resistant module (W)	cm ³ /m	1.496	
Acoustical insulation Rw (C;Ctr)	dB	29 (-1; -3)	ISO 717-1: 2013
Sound reduction (Rw)	dB	33.3 ± 1.30	
Thermal resistance (R)	m ² K/W	0.0168	
Thermal transmittance (U)	W/m ² K	3.38	UNE-EN ISO 12567-1
Thermal conductivity (λ)	W/m°C	0.4028	
Operating temperature	°C	- 50 / + 80	

A2 CORE SPECIFICATIONS	UNIT	VALUE	NORM
Density	g/cm ³	2.20 ± 0.15	
Fire reaction		A2 – S1, d0	UNE-EN 13501:2018

ALUMINIUM TECHNICAL SPECIFICATIONS	UNIT	VALUE	NORM
Alloy		5005	3005/3105*
		H42/H44	H42/H44
Modulus of elasticity (E)	N/mm ²	70000	70000
Proof stress (R _{p0.2})	N/mm ²	≥ 80	≥ 110
Tensile strength (R _m)	N/mm ²	125 ≤ R _m ≤ 205	130 ≤ R _m ≤ 215
Elongation (A ₅₀)	%	≥ 3	≥ 4
Density (ρ)	kg/m ³	2700	2700
Thermal expansion (α)	mm/m (100°)	2.36	2.36
			UNE-EN ISO 10545:1997

Use specifications:

There may be limitations in the manufacture of STACBOND A2 panels with high gloss finishes. Please consult STAC for compatible finishes.

* Aluminium alloy 5005 available by customer request.

** Check with us for other dimensions.

STACBOND FR

Fire retardant ACP

STACBOND FR panels are composed of two aluminium sheets with a fire retardant core made of thermoplastic resins with mineral load.

The panels have excellent mechanical properties including: high rigidity, excellent flatness and impact resistance.

They comply with the majority of requirements for fire-resistance classification:

- ✓ UNE-EN 13501:2018 — **B-s1, d0**
- ✓ PN-B-02867:2013 — **NRO**
- ✓ NFPA 285 — **PASS**
- ✓ ASTM E84 — **A CLASS**
- ✓ CAN/ULC-S102 — **SD: 0 FS: 0**
- ✓ ULC-S134 — **PASS**

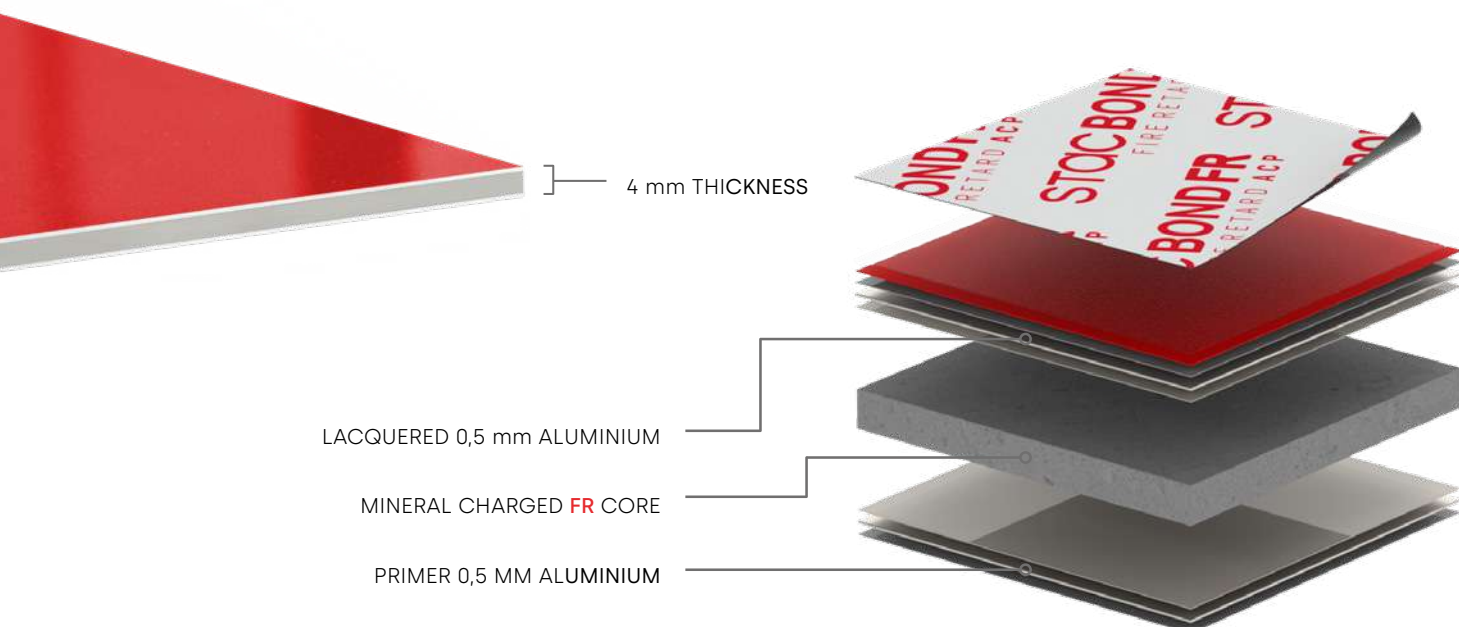

PANEL PHYSICAL SPECIFICATIONS

Panel thickness (mm)	Panel weight (kg/m ²)	
	Visible aluminium thickness of 0.5 (mm)	Visible aluminium thickness of 0.3 (mm)
3	6.10	5.40
4	7.70	7.40
5	9.50	—
6	11.20	—

ALUMINIUM ALLOY	VALUE	NORM
Visible face	5005	UNE EN 573-3
Hidden face	3005 / 3105*	

SHEET DIMENSIONS	UNIT	VALUE
Width (min./max.)	mm	800 / 2000**
Length (min./max.)	mm	2000 / 6000**
Thickness tolerance	mm	- 0.15 / + 0.10
Width tolerance	mm	- 0 / + 2
Length tolerance	mm	- 0 / + 10
Squareness (diagonal tolerance)	mm	± 3
Protective film width tolerance	mm	0 ; -5

PANEL TECHNICAL SPECIFICATIONS	UNIT	VALUE	NORM
Peeling	N/mm	≥ 9.80	ASTM D903 - 98 (2004)
Rigidity (EI)	kNcm ² /m	2610	DIN 53293
Resistant module (W)	cm ³ /m	1.496	
Acoustical insulation Rw (C;Ctr)	dB	33 (-1; -4)	ISO 717-1: 2013
Sound reduction (Rw)	dB	33.30 ± 1.30	
Thermal resistance (R)	m ² K/W	0.014	UNE-EN ISO 12567-1
Thermal transmittance (U)	W/m ² K	3.38	
Thermal conductivity (λ)	W/m°C	0.448	
Operating temperature	°C	- 50 / + 80	

FR CORE SPECIFICATIONS	UNIT	VALUE	NORM
Density	g/cm ³	1.50 ± 0.15	
Fire reaction		B - S1, d0	UNE-EN 13501:2018

ALUMINIUM TECHNICAL SPECIFICATIONS	UNIT	VALUE		NORM
Alloy		5005	3005/3105*	UNE EN 573-3
		H42/H44	H42/H44	UNE-EN 515
Modulus of elasticity (E)	N/mm ²	70000	70000	
Proof stress (R _{p0.2})	N/mm ²	≥ 80	≥ 110	
Tensile strength (R _m)	N/mm ²	125 ≤ R _m ≤ 205	130 ≤ R _m ≤ 215	EN 485-2
Elongation (A ₅₀)	%	≥ 3	≥ 4	
Density (ρ)	kg/m ³	2700	2700	
Thermal expansion (α)	mm/m (100°)	2.36	2.36	UNE-ENISO 10545:1997

* Aluminium alloy 5005 available by customer request.

** Check with us for other dimensions.

STACBOND COMPOSITE PANEL

CLEANING AND MAINTENANCE

PRODUCT MAINTENANCE

STACBOND composite panels present an optimal behaviour against possible changes in appearance caused by prolonged exposure to normal climatic conditions.

Facades made of composite panels are exposed to many aggressive agents present in the environment, such as sulphurous compounds, acids and nitrogen compounds caused by acid rain, chemical salts, dirt, soot, etc. These substances mixed with water and combined with UV radiation from the sun can lead to deterioration of the surface finish and shorten life expectancy of the product. These effects are worse in areas where rainwater cannot wash away the impurities.

As long as care is taken to keep the coating in good condition through regular washing and to ensure that incompatible or highly contaminated materials do not come into contact with the surface, the coating will not crack or delaminate, but changes may occur to the uniform appearance, such as slight changes in colour and brightness.

Specifically, for particularly harsh or difficult environments, such as areas with high levels of UV, areas at risk of sandstorms, proximity to chemical factories, swimming pools, saline environments or areas not exposed to natural rain, more rapid deterioration may occur.

For these reasons, the cleaning of roofing and facades is an important part of the care and maintenance of the cladding.

Regular inspection and maintenance is recommended to maintain the optimal appearance and durability of the coated aluminium. Above all, areas not exposed to natural rain, such as overhangs, may need further cleaning to eliminate potentially corrosive deposits. Leaves, grass, mould and other objects should be removed and any obstructions should be cleaned to prevent overflow. Local defects that can cause premature deterioration of the coating or corrosion of the substrate should be examined and repaired.

CLEANING*

Dirt and stained areas can be cleaned with water and as oft brush. A moderate strength power washer can also be used. The surface should then be rinsed down.

For more stubborn stains a pH neutral soap should be used. The detergent must be thoroughly removed after a few minutes with water. To remove a stain, a soft cotton cloth (or similar) wetted with a non-aggressive solvent such as mineral alcohol may be used.

Cleaning the façade should be carried out from top to bottom so that any detergent is washed away completely. The use of strong or detergents or those which are inappropriate for coloured surfaces may damage the finish. If necessary, we recommend carrying out a test clean on a small, low-visibility area of the panel.

We recommend carrying out cleaning of the façade when climatic conditions allow (avoiding high temperatures or strong, direct sunlight).



Moderate pressure washer



Use of neutral detergents



Washing from top to bottom

* Some special finishes require specific cleaning processes. In the vent of doubt, please consult info@stacbond.es

HANDLING

For proper storage and handling of the **STACBOND** aluminium composite panel, the following information should be taken into account:

- Pallets must be handled carefully during transport and unloading, always use suitable equipment such as fork-lift trucks. Never move open pallets.
- Whenever possible, store the material in a dry, dust-free interior space and under temperature conditions between 10° – 40° C.
- If stored outdoors, avoid exposing the material to sunlight by protecting it with an opaque protective cover.
- Always store the pallets in a horizontal position up to a maximum of 6 pallets of the same format stacked on top of each other (4 in case of **STACBOND A2**) or 12.500 Kg total weight.
- The plastic film must be removed from the pallets no later than 6 months after receipt.
- The individual panels should be lifted from the pallet supported by its four corners, avoiding dragging one over the other. Whenever possible, move the individual panels in an vertical position.

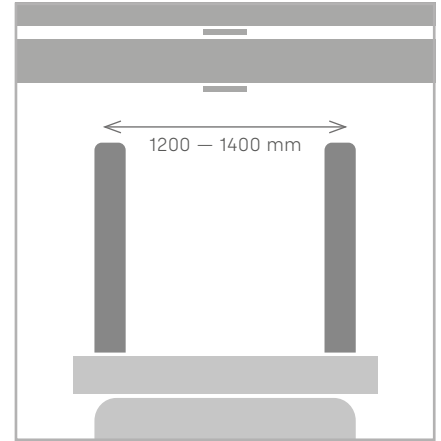

Optimal distance between forklift blades for transporting **STACBOND** composite panel pallets.

PROTECTIVE FILM

The protective film used is a temporary surface protector and once the panel is installed in the facade it should be removed as soon as possible as climatic factors (hours of exposure, climate zone, geographic location or sharp changes in temperature) may affect the adhesive used on the protective film and make removal more difficult.

For the machining and later installation of the **STACBOND** composite panel on the facade, it must be ensured that the orientation of the arrows indicated on the protective film must be the same on the entire surface, in order to avoid variations in the tone of the finish.

To ensure the integrity and proper functioning of the **STACBOND** aluminum composite panel protective film, the following information should be considered:

- Prolonged storage of the material with high temperature variations can affect the adhesion of the protective film, making it difficult to remove.
- Do not mark with inks that can pass through the protective film and affect the surface of the panel
- Remove the protective film at the latest one month after the installation of the composite panel in the project. Whenever possible, remove it under temperature conditions higher than 10° C. At the moment of removal, the film must be completely removed from the entire visible part of the façade, as partial removal may cause stains or marks to appear on the front face of the panel.

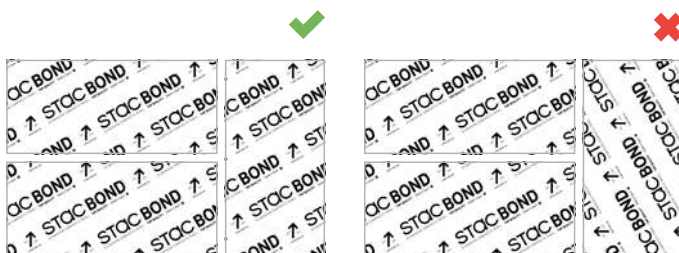

STACBOND COMPOSITE PANEL

PANEL TRANSFORMATION

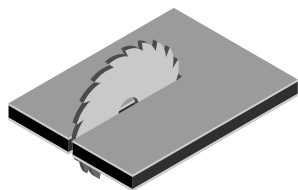

CUTTING

STACBOND composite panel can be cut using CNC machinery or manually using a wall saw or portable milling machine. Straight, curved and angled cuts are possible, depending on the tools used.

Consult STACBOND for the recommended parameters for the different types of cutting and the machinery used.

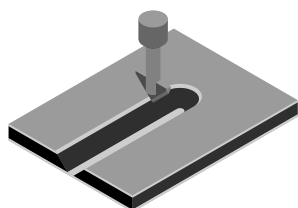

MILLING

Performed using CNC, wall saw with milling disk or portable milling machine. The partial milling of the panels allows them to be bent into shape. The scoring is done using 90° or 135° milling bits depending on the bend required. To achieve the desired measurements, the fold must be made on the axis of the milling score line. The remaining thickness of the panel allows it to be bent into shape by hand using specific tools or using a composite panel specific press brake.

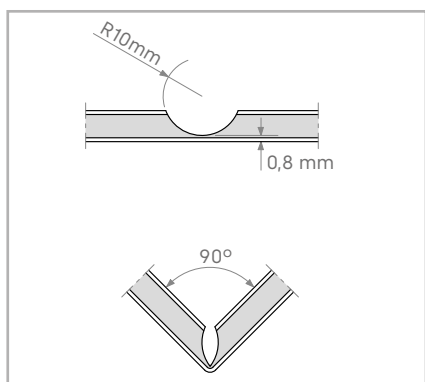

Spherical milling groove for 90° bends.

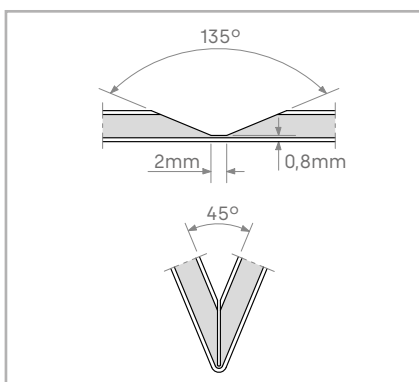

V-shaped milling groove for 135° bends.

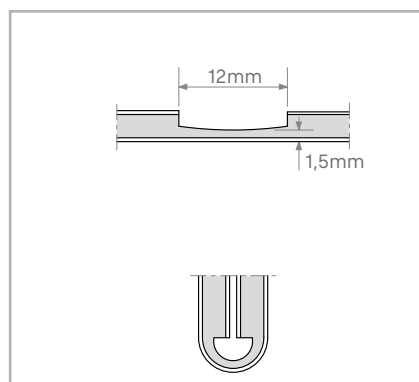

*Arc milling groove for complete 180° folds.

*Not suitable for A2 panel.

RECOMMENDED MILLING PARAMETERS:

CORE	PROCESS	ROTATIONAL SPEED (r.p.m.)	DISPLACEMENT SPEED (mm/min)
STACBOND A2	CUTTING	20.000 – 22.000	8.000 – 10.000
	MILLING	22.000 – 24.000	10.000 – 12.000
STACBOND FR	CUTTING	24.000	12.000 – 15.000
	MILLING	24.000	15.000 – 18.000

Note: these values are for guidance only and are intended for use with STACBOND recommended milling tools. For use with other tools or depending on the type of machine it is necessary to adjust them.

RECOMMENDED TOOLS A2 CORE:

- Cutting tool: Ø 6mm milling cutter with diamond insertions (STB-FRESA6PCD).
- Milling tool: Ø 10mm spherical milling cutter with diamond insertions (STB-FRESA10PCD).

RECOMMENDED TOOLS FR CORE:

- Cutting tool: Ø 6mm milling cutter with diamond insertions (STB-FD6X80X3,8).
- Milling tool: Ø 10mm spherical milling cutter with diamond insertions (STB-FEMD-10x72).

EMBOSSING AND ENGRAVING

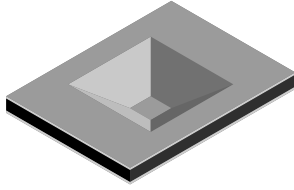

STACBOND composite panels can be embossed and engraved using CNC machines. There are limits on the depth achievable depending on the shape and size of the tool used.

Please consult **STACBOND** about different possible methodologies.

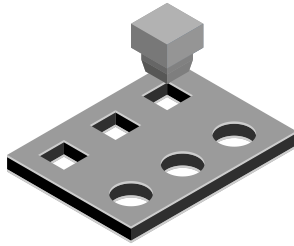

PUNCHING AND DIE-CUTTING*

STACBOND composite panels can be punched or die-cut using CNC machines. The recommended parameters to maintain the panels properties and thus their guarantee are as follows:

- The smallest punch diameter should be 4 mm.
- The distance between centres must be at least double the diameter.
- The perforated surface area must be less than 35% of the total surface area of the panel.

Consult **STACBOND** about possible formats.

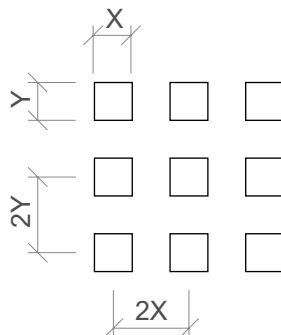
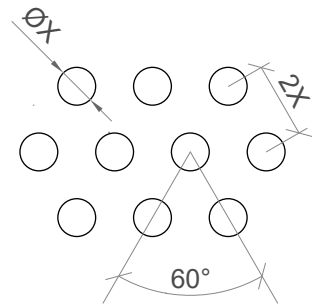
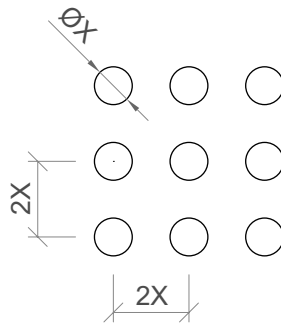

* For perforation parameters with **STACBOND A2** panels, please check with the **STACBOND** technical department.

STACBOND COMPOSITE PANEL

PANEL TRANSFORMATION

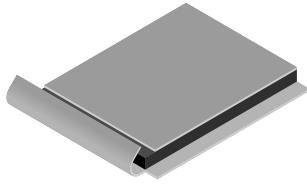

EDGE FOLDING OF BORDERS

STACBOND composite panels can be edge folded on their profile. We offer three types of border: Simple (hides border), double interior (hides the border and part of the reverse) and double exterior (hides border and has a tab sticking out which hides the joint with other sheets of the panel). The dimensions of the panel must be oversized to account for the requirements of each type of border.

	SIMPLE FOLDING	DOUBLE INTERIOR FOLDING	DOUBLE EXTERIOR FOLDING
UNFOLDED DIAGRAM			
FOLDED DIAGRAM			
FLAP INCREASE (mm)	3,5	7,5	14,0

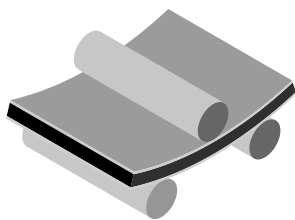

BENDING WITH ROLLERS

To make curved panels the best system is using a bending machine with 3/4 rollers. To avoid risk of damage, attention must be paid to the minimum radius of the curve of the internal side.

In the case of STACBOND composite panels with flaps, the minimum recommended radius is 500 mm for a maximum flap length of 20 mm.

The minimum bending radius without flaps is determined by the following formula:

$$\varnothing \text{ UPPER ROLLER} \times 1,5 / 2 = \text{BENDING RADIUS}$$

For example, in a machine where the diameter of the upper roller is 200 mm, we could bend a 4 mm thick composite panel sheet with a minimum radius of 150 mm.

Bending without flaps of lower radius can be achieved by using press brakes with specific tools. Consult STACBOND for more information.

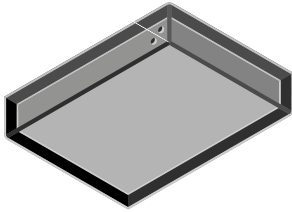

FORMING CASSETTES*

The cassettes in the **STACBOND** systems are formed by bending the perimeter tabs. These tabs are made by partial milling of the panel with the correct dimensions for the system used. For fastening/anchoring the panels, various specific parts are used, such as strips made of aluminium or from the same material as the panel itself, which are attached using rivets. During the forming process we recommend that the panel be duly protected to avoid superficial damage. This process also can be used to form surfaces with three-dimensional relief.

*It is not recommended to fold the tabs of the **STACBOND A2** panel more than twice.



Assembly systems



ASSEMBLY SYSTEMS

STACBOND offers 10 assembly systems to provide new possibilities and solutions for modern architecture. These systems have been meticulously designed to adapt to the specific requirements of each project.

These systems for the installation of **STACBOND** composite panels are split into two main groups depending on the substructure:

T SUBSTRUCTURE

- **STB-T-CH** (hanger system)
- **STB-T-CH-PRO®** (hanger system)
- **STB-T-SZ** (male-female system)
- **STB-T-SZ-PRO®** (male-female system)
- **STB-T-REM** (riveted system)
- **STB-T-PEG** (glued system)

OMEGA SUBSTRUCTURE

- **STB-CH** (hanger system)
- **STB-SZ** (male-female system)
- **STB-REM** (riveted system)

The **STB-T-CH**, **STB-T-CH-PRO®**, **STB-T-SZ**, **STB-T-SZ-PRO®**, **STB-T-REM** and **STB-T-PEG** systems employ special L spacers and T profile.

The **STB-CH**, **STB-SZ** and **STB-REM** systems employ the same substructure elements, DOUBLE T spacers and OMEGA profile.

The STACBOND **STB-T-CH**, **STB-T-SZ**, **STB-T-REM**, **STB-CH**, **STB-SZ** and **STB-REM** installation systems for **STACBOND** composite panels have the European technical evaluation document ETE/ETA 15-0655 and CE marking according to EAD guide 090062-00-0404.

STB-T-CH

HANGER SYSTEM

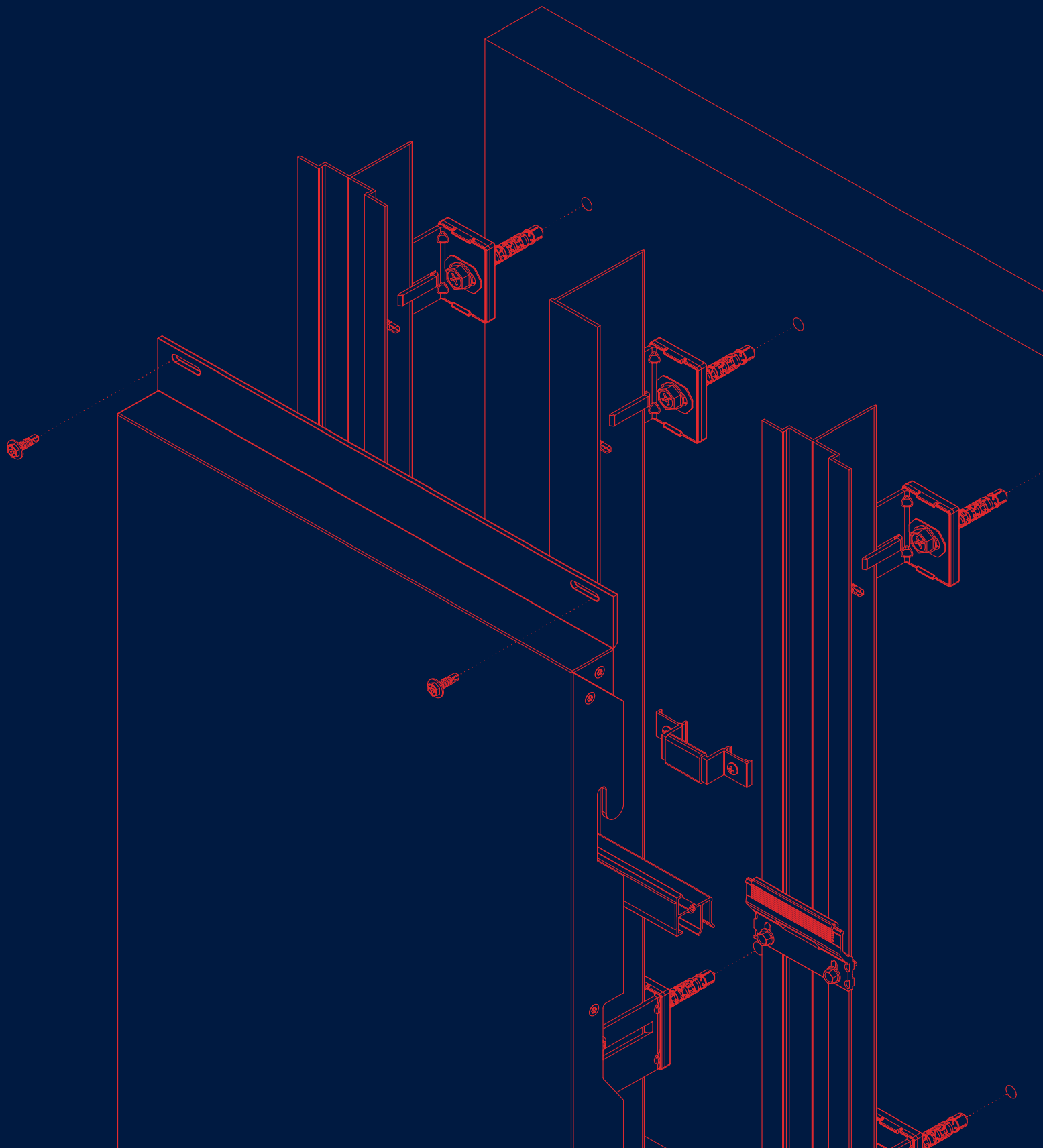

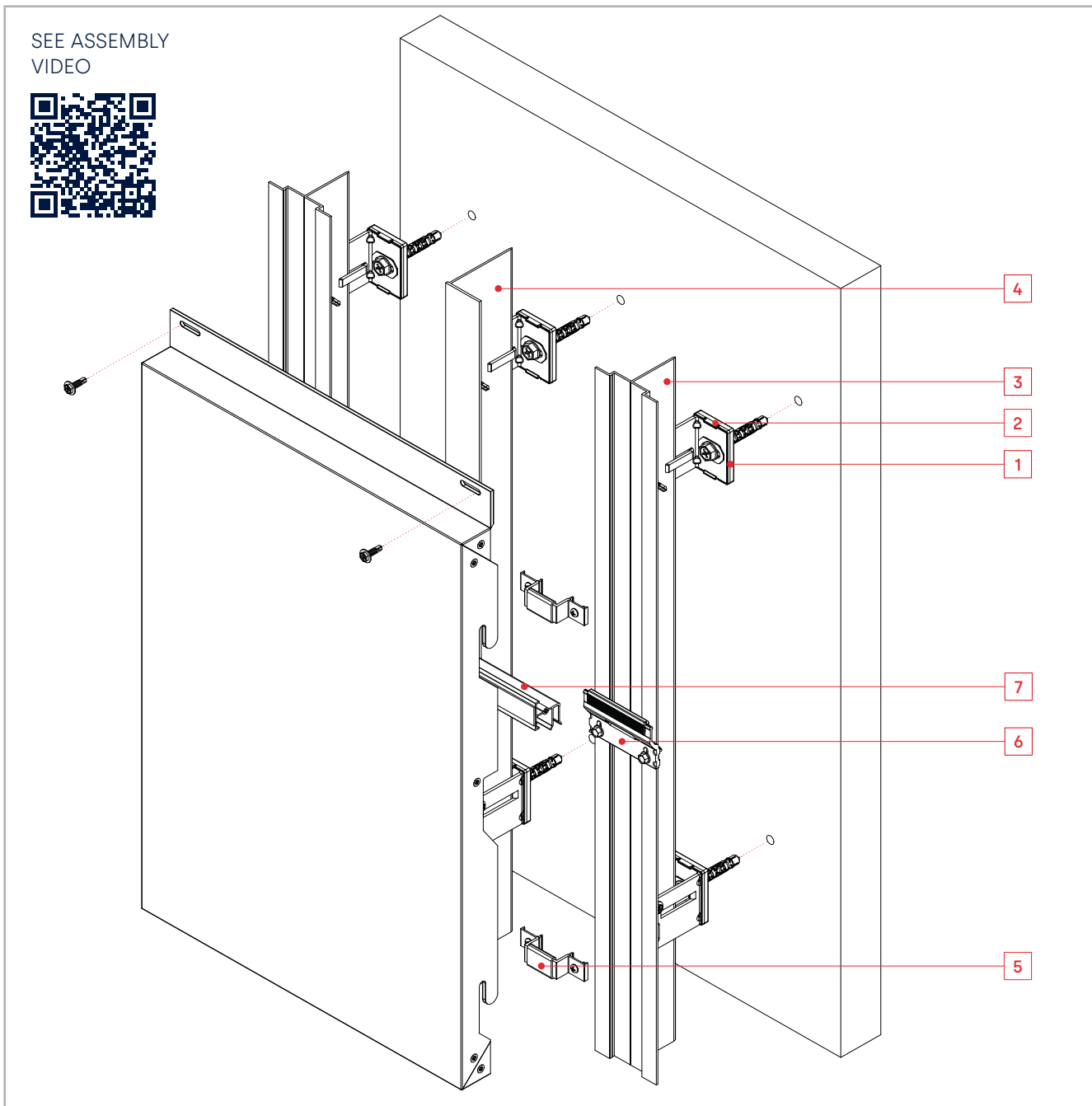

The **STB-T-CH** is a kit system based on hanging cassettes made of **STACBOND composite panels for the assembly of ventilated façades**. It is a versatile, fast-assembly, concealed fixing system, specially designed to develop façades with horizontal or vertical modulation.

The substructure intended to support the formed CH panels is composed of **L-spacers** (alloy 5005 H24 or INOX AISI 304/430) and **T-OMEGA profiles** (alloy 6063 T5/T6).

These spacers have different lengths to accommodate the required thickness of thermal insulation and to absorb all the irregularities of the façade. For the

thermal bridge break, **STAC** has developed specific **GROOVE WASHERS** to be placed between the spacers L and the wall facing.

The connection of the formed cassettes to the substructure is achieved by means of recesses in the vertical flanges of the cassettes and their hidden stiffeners attached on the rear face, so that they rest on the hanger supports and are screwed or riveted to the profiles T-OMEGA.

The **STB-T-CH** system complies with the main international certifications.

INSULATING WEDGE AND GROOVE WASHER (1)

REF. 05.19.068 / 05.19.072 / 05.19.066

REF. 05.19.070

Optional insulating wedges and insulation covers, for eliminating thermal bridges in spacers.

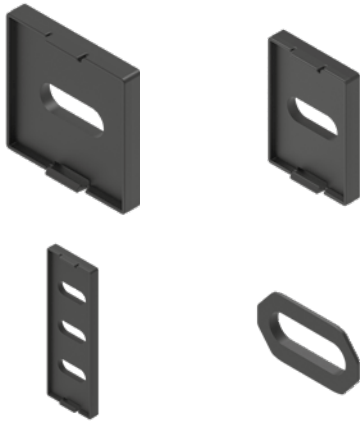

SPACER DOUBLE L

REF. 05.19.042 / 05.19.045

Designed to jointly connect two studs to the supporting wall.

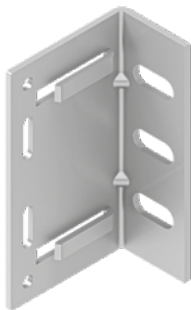

PROFILE L INTERMEDIATE (4)

REF. 05.19.059

Designed to be located in the middle of two T-OMEGAS in order to lighten substructure, supporting the horizontal stiffener and its corresponding bracket.



SPACER L (*) (2)

REF. 05.19.041 / 05.19.044 / 05.19.051 / 05.19.052 / 05.19.053 / 05.19.054 / 05.19.055 / 05.19.056

Designed to connect the studs to the supporting wall. Available in different sizes depending on the desired system thickness.

(*) Also available in stainless steel

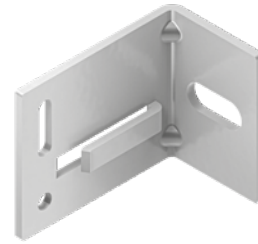

PROFILE T-OMEGA (3)

REF. 05.19.061

In vertical joints between cassettes and in an intermediate position, for fixing **T-CH HANGER SUPPORT**, CH cassette and **MINI** or **LONG** horizontal stiffener support.



BRACKET SET STB-T-CH HANGING (5)

REF. 05.19.062

For hanging the **CH cassettes** to the substructure. Clipped to the **PROFILE T-OMEGA** for easy adjustment and fixed with 2 self-drilling screws to the profile.

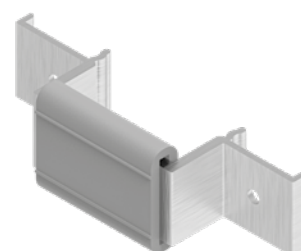

STB-T-CH SYSTEM

SYSTEM COMPONENTS

CH CASSETTE LOWER CLIP

REF. 05.19.108

It is placed next to the intermediate profiles to fix the cassette on its lower part and to facilitate its alignment.



CH HORIZONTAL STIFFENING BRACKET (6)

REF. 05.19.106 / 05.19.105 / 05.19.109

Available in **LONG**, **SHORT** and **MINI** sizes, depending on the profile type on which it should be installed.

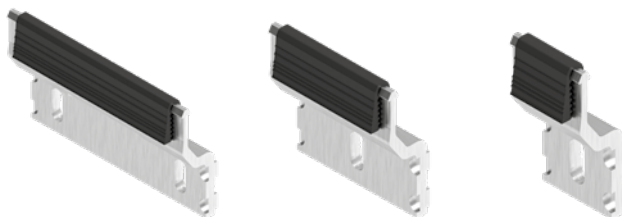

STIFFENER SCH

REF. 05.19.025 / 05.19.026 / 05.19.027 / 05.19.027.1 / 05.19.027.2 / 05.19.027.3

Attaches to the back of the cassette with elastic adhesive. Enables the execution of larger cassettes.



STIFFENING PROFILE (7)

REF. 05.19.107

It is fixed to the back of the cassette, fits on specific supports, and allows the execution of larger cassettes (width and height).

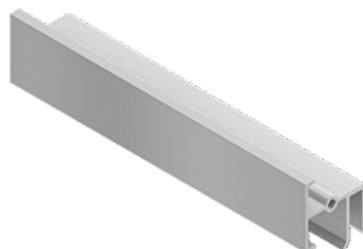

CASSETTE FORMING PLATE

REF. 05.19.050

It is used for forming, together with rivets, the corners of cassettes with 45 mm vertical flange.



REINFORCEMENT PLATE FOR HANGER

REF. 19.019

It is used for forming, together with rivets, in all cassettes with a vertical flange of 40 mm.



ANCHOR AND SCREW

REF. STB-T0800 / STB-T0801

For fixing the spacer to concrete or masonry. The specific load shall **be checked by extraction test according to ETAG 020.**



SEPARATOR / UPRIGHT FIXING SCREW

REF. STB-T0300 / STB-T0310 / STB-T0311 / STB-T0312

For fixing the upright to the spacer.



SCREW FIXING TO UPRIGHT

REF. STB-T0600 / STB-T0610

For attaching **CH cassette**, STB-T-CH HANGER SUPPORT, or CH HORIZONTAL STIFFENING SUPPORT, to the T-OMEGA or L profile.

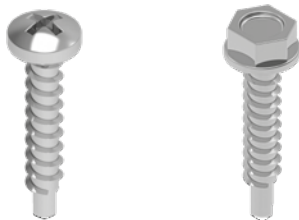

FLAT HEAD SCREW (*)

REF. STB-T0700

For attaching stiffeners to the cassette at the ends.

(*) Possibility of delivery lacquered



FORMED RIVET (*)

REF. STB-R0300

For cassette forming.

(*) Possibility of delivery lacquered



STB-T-CH SYSTEM

STANDARD CH WING CASSETTE 45mm

STB-T-CH standard tray panel hooks are cut out during machining process so they can be hung on previously installed hanging devices.

The cassette is formed by means of rivets and specific forming plates.

Once the cassette is in place, it is fixed to the upright by means of a self-drilling screw through the upper flange.

UNFOLDED CASSETTE

FORMED CASSETTE

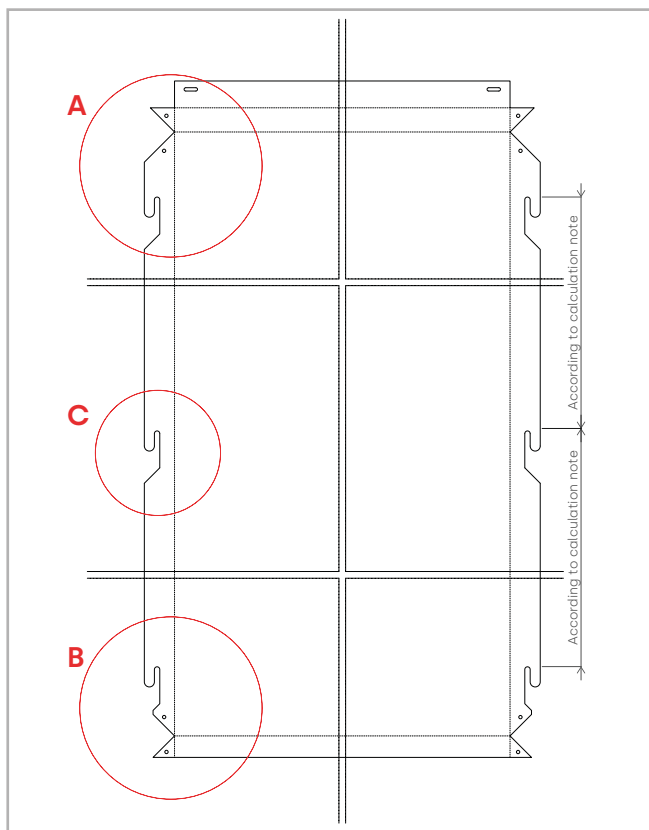

DETAIL A

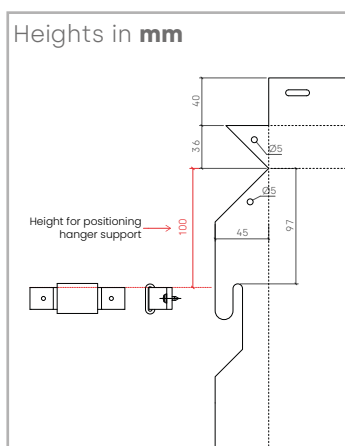

DETAIL B

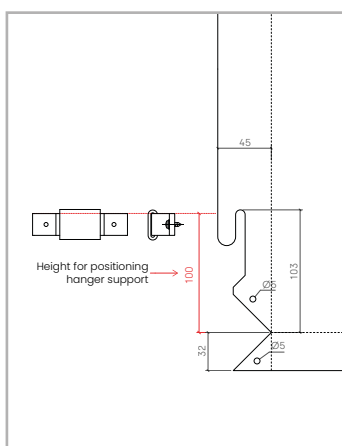

DETAIL C

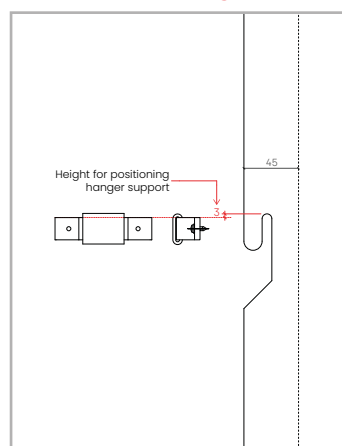

SEE CASSETTE FORMING VIDEO



STB-T-CH SYSTEM

STANDARD CH WING CASSETTE 40 mm

STB-T-CH standard tray panel hooks are cut out during machining process, in this case on 40 mm wide vertical flaps so they can be hung on previously installed hanging devices.

The cassette is formed by means of rivets and specific hanger supports, to be placed on all the footings of the cassette.

Once the cassette is in place, it is fixed to the upright by means of a self-drilling screw through the upper flange.

UNFOLDED CASSETTE

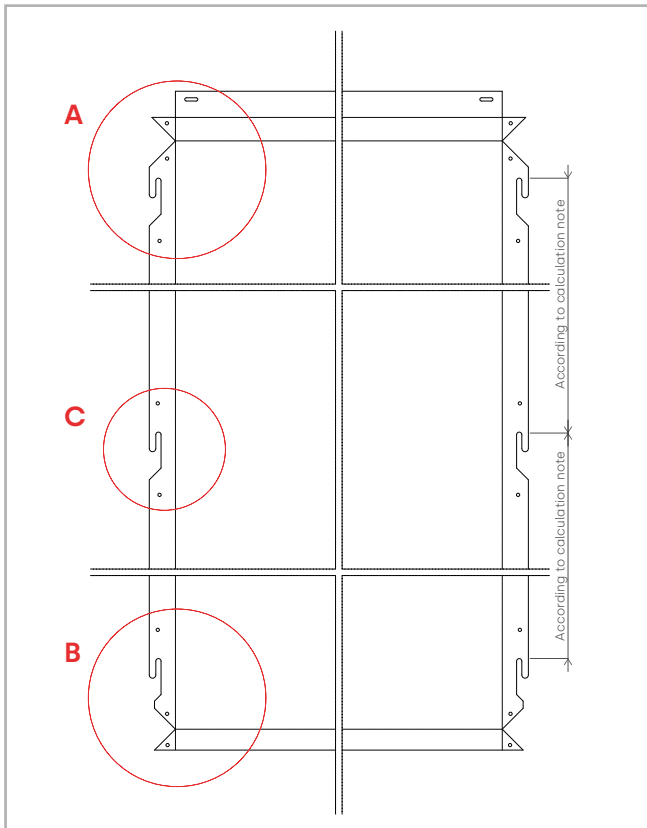

FORMED CASSETTE



DETAIL A

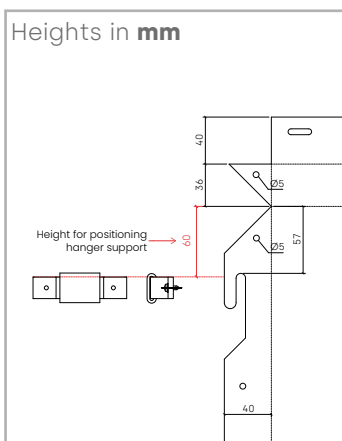

DETAIL B

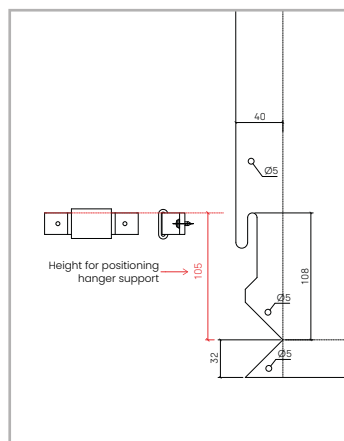

DETAIL C

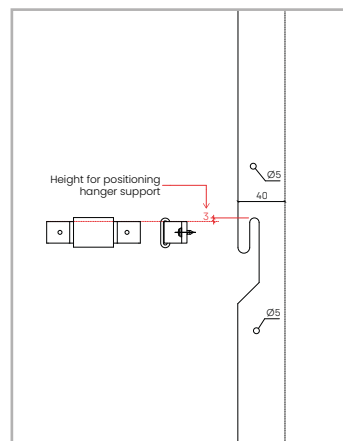

STB-T-CH SYSTEM

VERTICAL CASSETTE STIFFENER

VERTICAL STIFFENER

The vertical stiffener is a corner-shaped piece formed from machined **STACBOND** composite panel. It is used to reinforce CH cassettes, when they exceed certain dimensions. The stiffener is attached by double-sided tape and adhesive to the inside face of the cassette and riveted to the horizontal upper and lower flanges.



1. PREPARATION OF THE AREA

Dust and dirt shall be removed using mechanical processes, which shall consist of more or less deep sanding, depending on the existing dirt. Once cleaned, the area shall be primed with a specific product that reinforces the adhesion of the elastic adhesive SIKATAACK PANEL PRIMER (or similar).

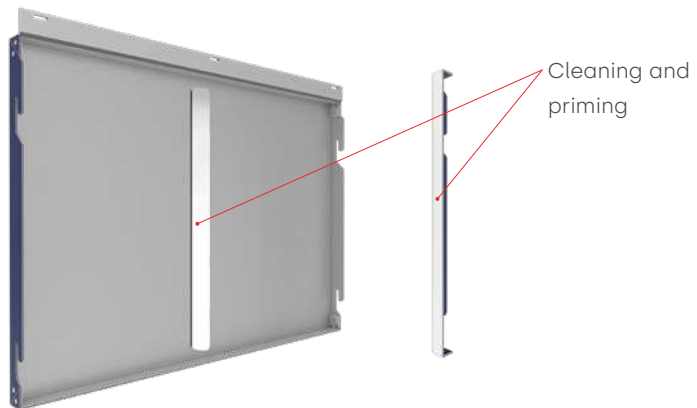

2. DOUBLE-SIDED ADHESIVE TAPE

After priming, the self-adhesive tape CINTA SIKATAACK PANEL-3 (or similar) shall be applied. Subsequently, the elastic adhesive SIKATAACK PANEL 50 (or similar) shall be spread over cassette surface by applying a continuous bead adjacent to the double-sided tape.



3. FITTING AND FIXING OF THE STIFFENER

The stiffener shall then be placed in such a way that the entire surface of the stiffener is impregnated with adhesive. Finally the stiffener shall be drilled and riveted at the top and bottom against the horizontal flanges of the cassette.

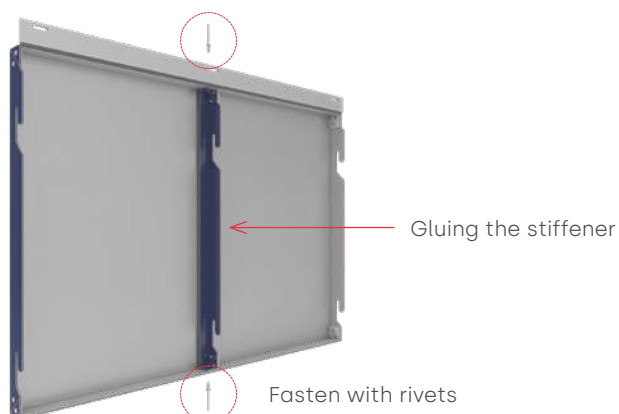

EVOLUTION OF SYSTEMS FROM **STB-T-CH** to **STB-T-CH evo®**

NEW COMPONENTS OF THE SYSTEM

NEW HORIZONTAL STIFFENER

The horizontal stiffener is an optional extruded aluminium profile, which allows the construction of **large CH cassettes in both horizontal and vertical modulations.**

The horizontal stiffener must be clipped into a set of custom single supports pre-fixed to all mullion profiles.

The use of these stiffeners not only eliminates the use of more expensive vertical stiffeners, but also allows the maximum spacing between studs to be increased.

With this new horizontal stiffener, the intermediate profiles can be executed with a lighter L-profile, fitted with the aforementioned stiffener supports instead of the classical T-OMEGA profiles with standard CH hangers, further increasing the savings in substructure.

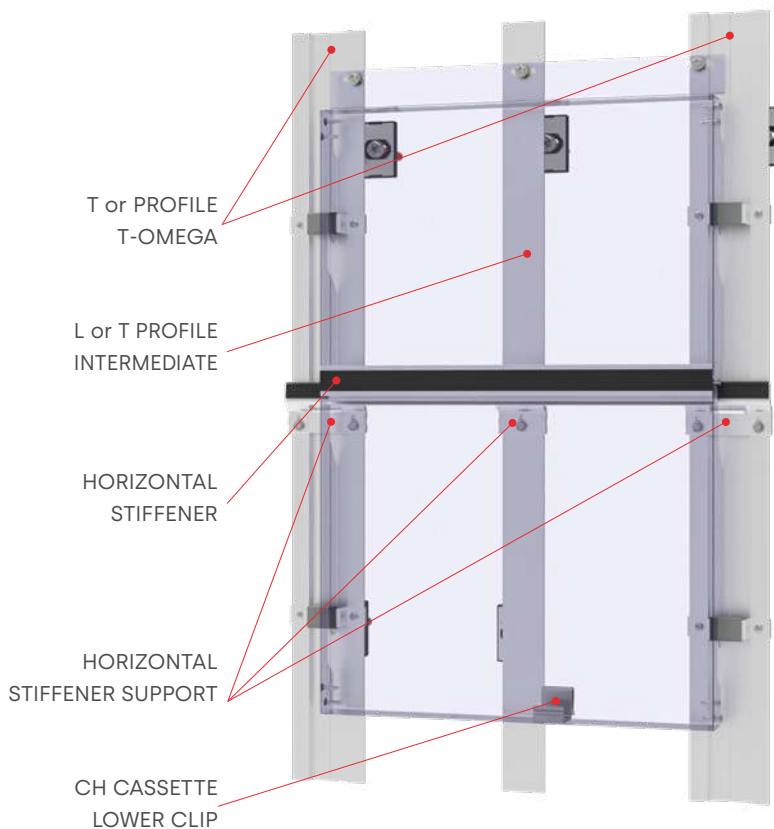

The number of stiffeners to be placed will be indicated in the wind calculation note issued by the **STACBOND** technical office.

HORIZONTAL STIFFENER PLACEMENT



Clean the gluing area of the stiffener and cassette with a specific cleaner.

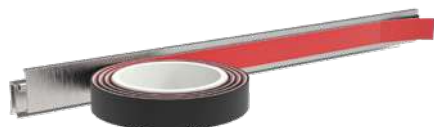

Glue with specific 1.6 mm thick structural tape.

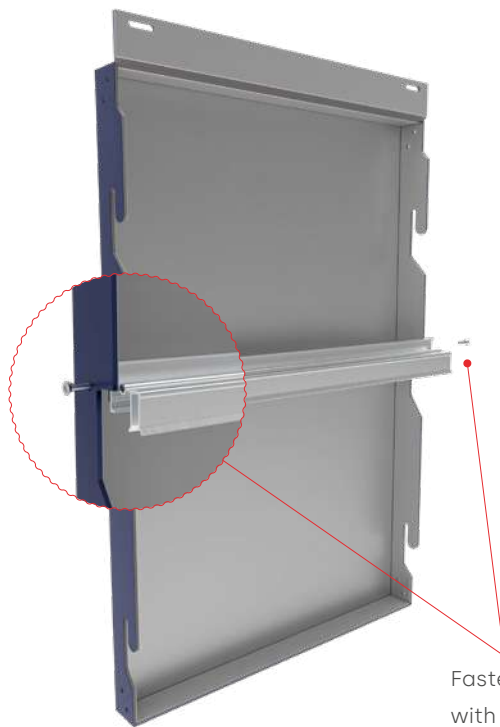

System compatible with Omega substructure.

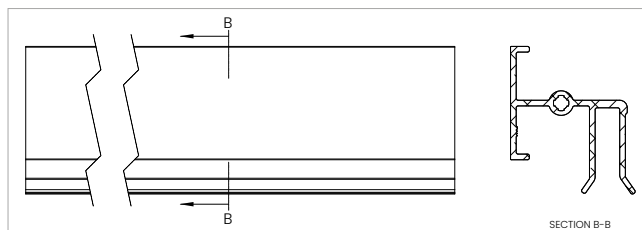

EVOLUTION OF SYSTEMS FROM **STB-T-CH** to **STB-T-CH evo®**

NEW ELEMENTS OF THE SYSTEM

The **STB-T-CH evo® system cassettes** are easier to machine than the STB-T-CH cassettes, as they have fewer hooks.

Therefore, machining, forming and installation is faster and more economical.

UNFOLDED CASSETTE

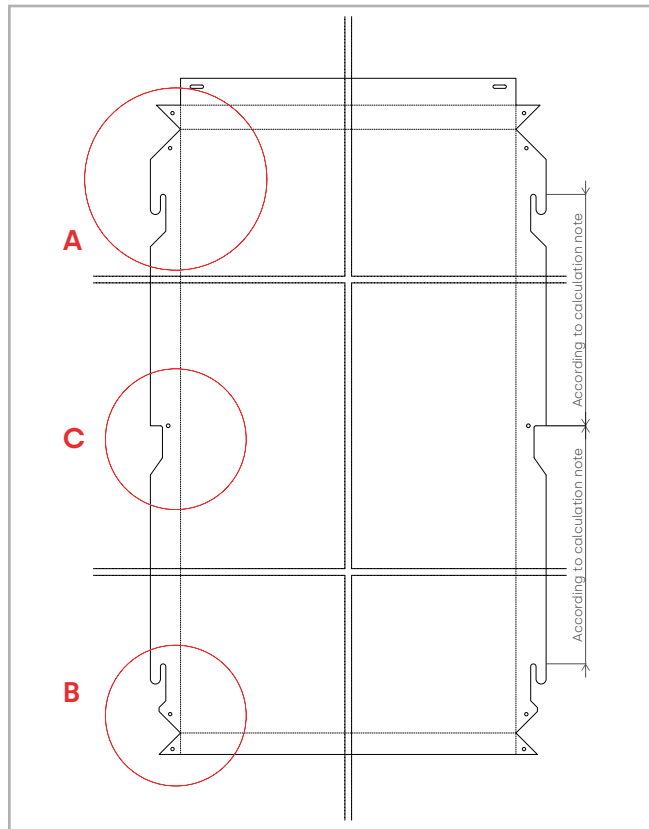

FORMED CASSETTE



DETAIL A

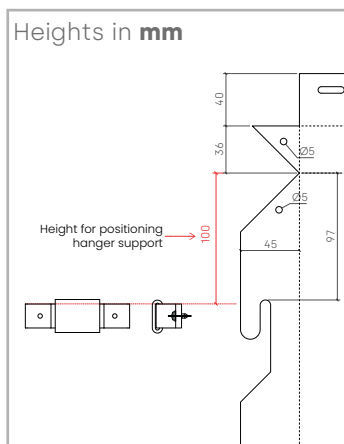

DETAIL B

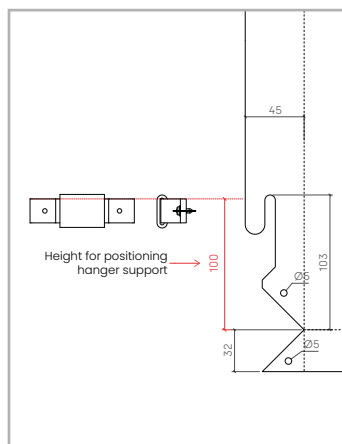

DETAIL C

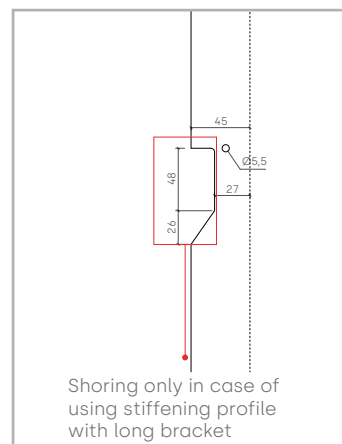

SEE CASSETTE FORMING VIDEO



EVOLUTION OF SYSTEMS FROM **STB-T-CH** to **STB-T-CH evo®**

NEW ELEMENTS OF THE SYSTEM

NEW BOTTOM CLIP CH CASSETTE

The new bottom clip is placed on the **bottom flange** of the **CH cassette**, right next to the intermediate profiles, in order to fix the CH cassette at the bottom and facilitate its alignment.

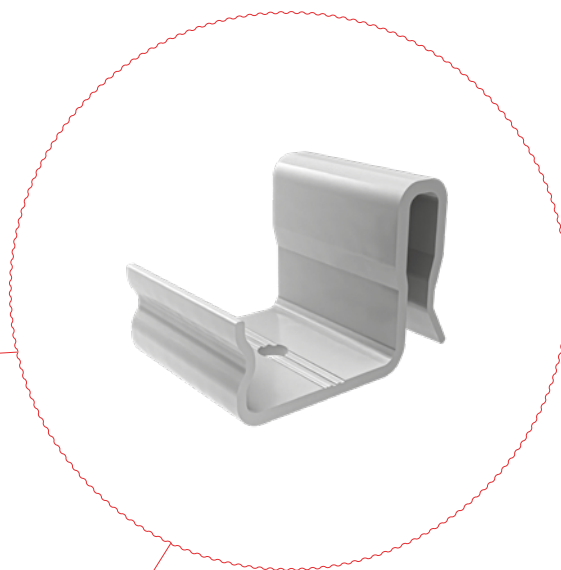
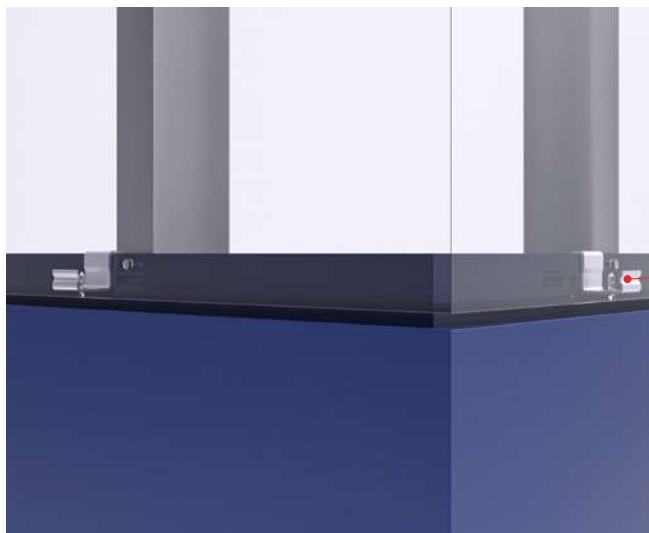

EVOLUTION OF SYSTEMS FROM **STB-T-CH** to **STB-T-CH evo®**

NEW FORMS OF MODULATION

HORIZONTAL AND VERTICAL MODULATIONS

Thanks to the placement of the stiffener, the **evo®** system allows horizontal and vertical modulations.

In addition to the versatility in modulation, it **allows a maximum spacing between vertical uprights of 1200 mm***, much wider than traditional CH.

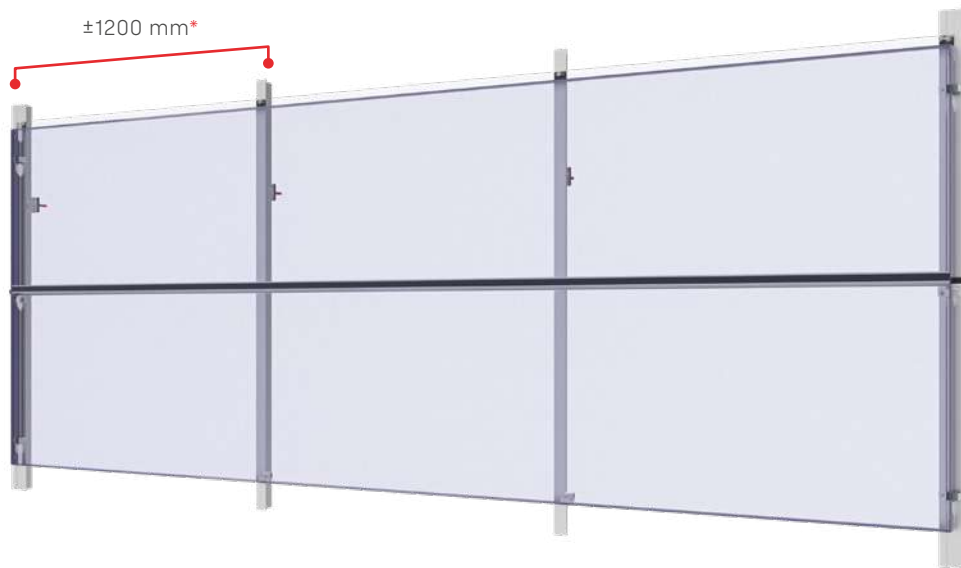

* Measurement to be consulted according to specific STACBOND calculation note.

SAVINGS IN MATERIALS



- Greater separation between uprights, allowing a saving in the amount of substructure to be used.
- The intermediate profile T-OMEGA is replaced by L-profiles, which are more economical.*
- The horizontal stiffener gluing system is more economical.

* Only at low wind loads

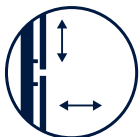

FACADES WITHOUT LIMITS

Possibility of an aesthetically cleaner vertical joint thanks to the mini hanger.

INSULATING WEDGES

REF.	COMPONENT
05.19.066	INSULATING WEDGE FOR SPACERS DOUBLE L WITH REF: 05.19.042 / 05.19.045
05.19.068	INSULATING WEDGE FOR SPACERS L WITH REF: 05.19.053 / 05.19.054 / 05.19.055 / 05.19.056 / 05.19.082 / 05.19.083 / 05.19.084 / 05.19.085
05.19.072	INSULATING WEDGE FOR SPACERS L WITH REF: 05.19.041 / 05.19.044 / 05.19.051 / 05.19.052 / 05.19.078 / 05.19.079 / 05.19.080 / 05.19.081
05.19.070	3 x GROOVE WASHERS FOR SPACERS L WITH REF: 05.19.066 / 05.19.068 / 05.19.072

SPACERS

REF.	COMPONENT
05.19.041	SPACER L 68
05.19.044	SPACER L 92
05.19.051	SPACER L 116
05.19.052	SPACER L 140
05.19.053	SPACER L 164
05.19.054	SPACER L 188
05.19.055	SPACER L 212
05.19.056	SPACER L 236
05.19.078	SPACER INOX L 61
05.19.079	SPACER INOX L 85
05.19.080	SPACER INOX L 109
05.19.081	SPACER INOX L 133
05.19.082	SPACER INOX L 157
05.19.083	SPACER INOX L 181
05.19.084	SPACER INOX L 205
05.19.085	SPACER INOX L 229
05.19.042	SPACER DOUBLE L 68
05.19.045	SPACER DOUBLE L 92

PROFILES

REF.	COMPONENT
05.19.043	PROFILE T
05.19.059	PROFILE L INTERMEDIATE
05.19.061	PROFILE T-OMEGA

ADDITIONAL COMPONENTS

REF.	COMPONENT
05.19.062	HANGER SUPPORT SET
05.19.108	CH CASSETTE LOWER CLIP
05.19.106	CH HORIZONTAL STIFFENER LONG BRACKET
05.19.105	CH HORIZONTAL STIFFENER SHORT BRACKET
05.19.109	CH HORIZONTAL STIFFENER MINI BRACKET
05.19.123	PIECE OF GASKET JOINT
05.19.025	STIFFENER SCH-1 (< 750 mm)
05.19.026	STIFFENER SCH-2 (750 - 1500 mm)
05.19.027	STIFFENER SCH-3 (1500 - 2400 mm)
05.19.027.1	STIFFENER SCH-4 (2400 - 4000 mm)
05.19.027.2	STIFFENER SCH-5 (4000 - 5000 mm)
05.19.027.3	STIFFENER SCH-6 (> 5000 mm)
05.19.107	STIFFENING PROFILE
05.19.050	CASSETTE FORMING PLATE

FIXING ACCESSORIES

REF.	COMPONENT
STB-T0800	ANCHOR + SCREW SET FOR FIXING BRACKET TO WALL X3 10X80 HEX. 3DG WIDE NECK
STB-T0801	ANCHOR + SCREW SET FOR FIXING BRACKET TO WALL SDF-KB-10X80-E A4 STAINLESS STEEL WIDE NECK
STB-T0300	SELF-TAPPING SCREW SDA5/3.5-6-H13-SA- 5.5X20
STB-T0310	SLIDING POINT BRACKET-PROFILE FIXING SCREW JT9-2/5-5.0x25 VARIO STAINLESS STEEL A4
STB-T0311	DRILL BIT JT4-3H/5-5.5x19 INOX-A2 - FIXED POINT
STB-T0312	DRILL BIT JT9-3H/5-5.5x19 INOX-A4 - FIXED POINT
STB-T0600	SELF-DRILLING SCREW 4.2x19 STAINLESS STEEL A2 DIN 7504-N ROUNDED CYLINDRICAL HEAD
STB-T0610	SELF-DRILLING SCREW 4.2x19 STAINLESS STEEL A2 DIN 7504-K HEXAGONAL HEAD
STB-T0700	FLAT HEAD SCREW - 4,2x20
STB-R0300	ALU/SS RIVET Ø4.8X12, D.HEAD 9.5



See all available accessories on
page 131

STB-T-CH SYSTEM

TOTAL THICKNESS RATIO, ACCORDING TO SPACERS AND INSULATOR

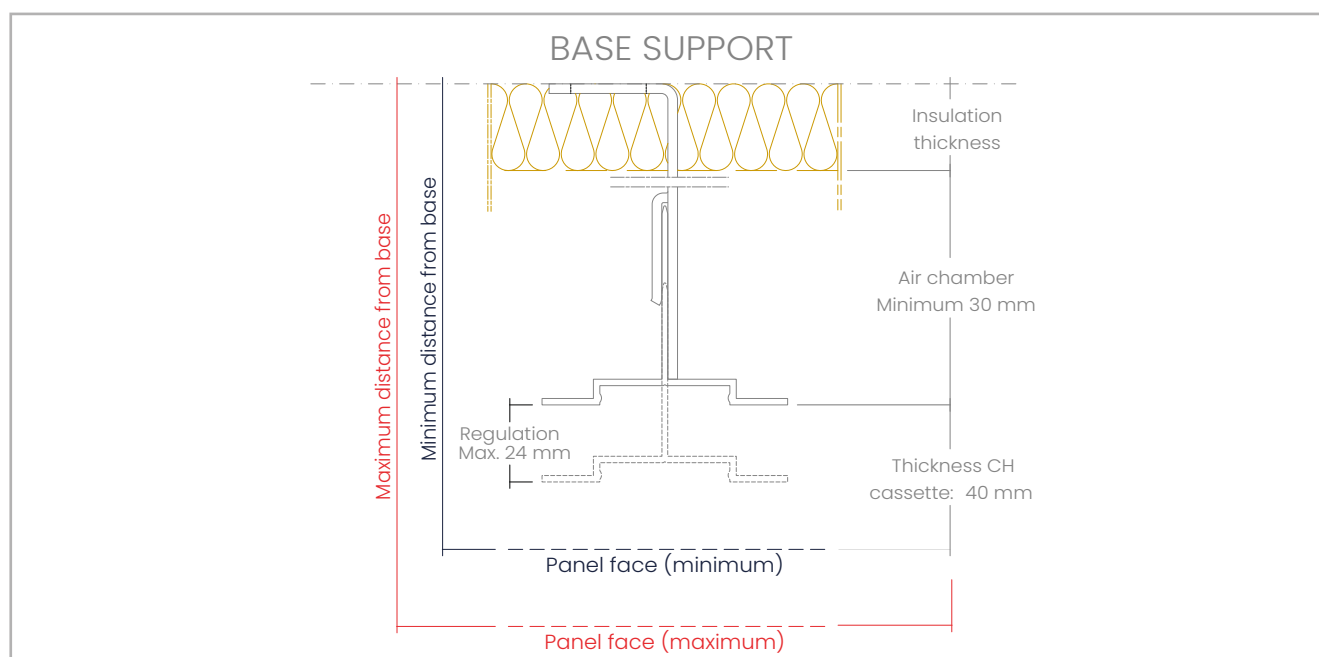

Note: the use of insulating wedges will increase the distance to the outer face of the panel by 5 mm.

SPACER L		DISTANCE (mm) FROM THE BASE OF THE ANCHORING TO EXPOSED PANEL FACE		INSULATING THICKNESS (mm) FOR 24 mm ADJUSTMENT*
REF.	COMPONENT	MINIMUM	MAXIMUM	MAXIMUM
05.19.041	SPACER L 68	118	142	—
05.19.044	SPACER L 92	142	166	40
05.19.051	SPACER L 116	166	190	60
05.19.052	SPACER L 140	190	214	80
05.19.053	SPACER L 164	214	238	110
05.19.054	SPACER L 188	238	262	130
05.19.055	SPACER L 212	262	286	160
05.19.056	SPACER L 236	286	310	180

SPACER INOX L		DISTANCE (mm) FROM THE BASE OF THE ANCHORING TO EXPOSED PANEL FACE		INSULATING THICKNESS (mm) FOR 24 mm ADJUSTMENT*
REF.	COMPONENT	MINIMUM	MAXIMUM	MAXIMUM
05.19.078	SPACER INOX L 61	112	136	—
05.19.079	SPACER INOX L 85	136	160	30
05.19.080	SPACER INOX L 109	160	184	60
05.19.081	SPACER INOX L 133	184	208	80
05.19.082	SPACER INOX L 157	208	232	100
05.19.083	SPACER INOX L 181	232	256	130
05.19.084	SPACER INOX L 205	256	280	150
05.19.085	SPACER INOX L 229	280	304	180

SPACER DOUBLE L		DISTANCE (mm) FROM THE BASE OF THE ANCHORING TO EXPOSED PANEL FACE		INSULATING THICKNESS (mm) FOR 24 mm ADJUSTMENT*
REF.	COMPONENT	MINIMUM	MAXIMUM	MAXIMUM
05.19.042	SPACER DOUBLE L 68	118	142	—
05.19.045	SPACER DOUBLE L 92	142	166	40

* For the calculation of the maximum admissible thickness, rigid insulation has been taken into account, guaranteeing the maximum regulation of each system and maintaining an air gap of ≥ 30 mm.

STB-T-CH-PRO®

HANGER SYSTEM

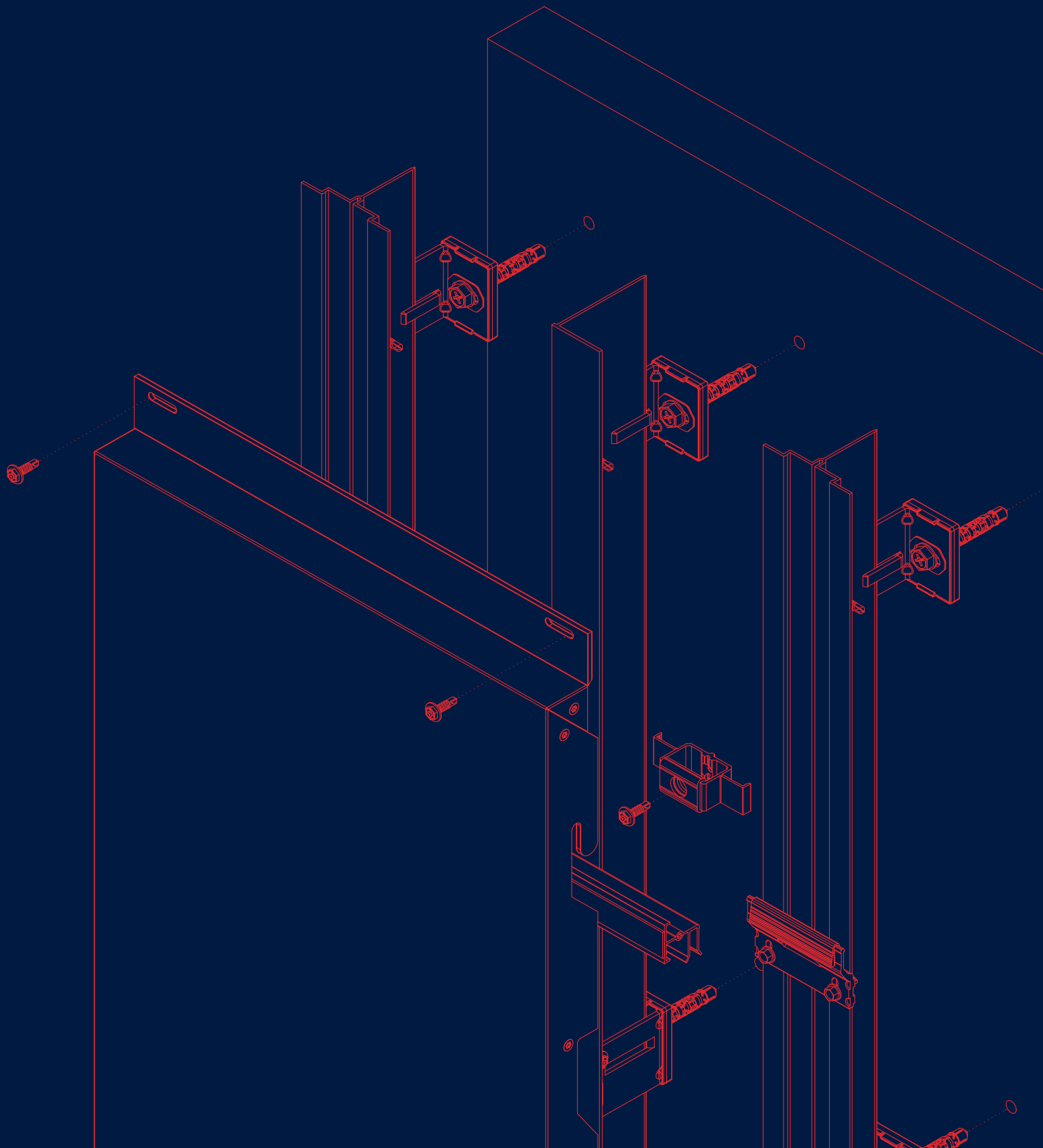

STB-T-CH-PRO® SYSTEM

DESCRIPTION

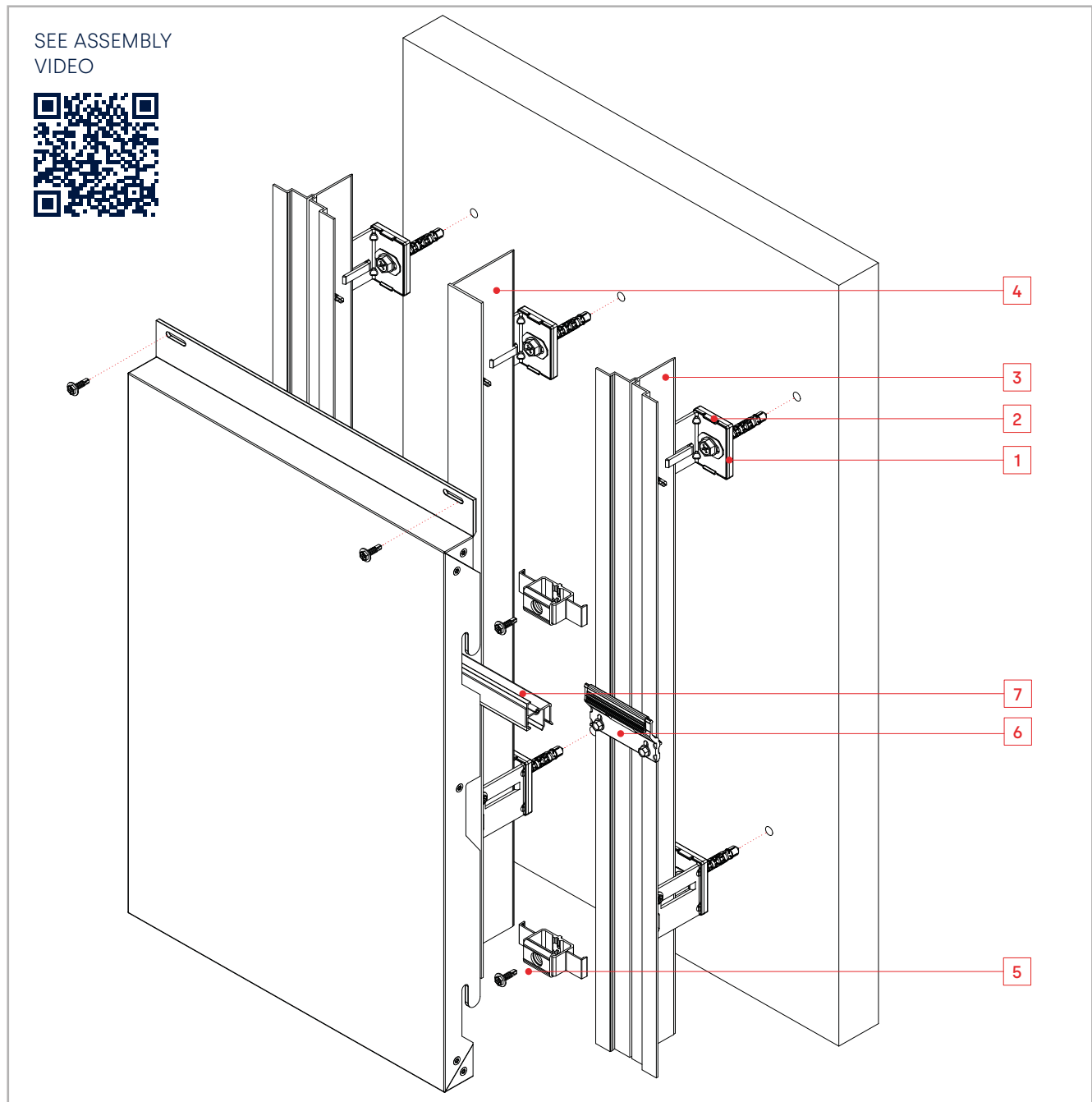

The **STB-T-CH-PRO®** is a kit system based on suspended cassettes made of **STACBOND composite panel for the assembly of ventilated façades**. It is a versatile, fast-assembly, concealed fixing system, specially designed to develop façades with horizontal or vertical modulation.

The substructure is composed of **L-spacers** (alloy 5005 H24 or INOX AISI 304/430) and new **STB-T-CH-PRO®** profiles (alloy 6063 T5/T6).

These spacers have different lengths to accommodate the required thickness of thermal insulation and to absorb all the irregularities of the façade. For the

thermal bridge break, **STAC** has developed specific **INSULATING WEDGES** to be placed between the spacers L and the wall facing.

The connection of the formed cassettes to the substructure is made by means of recesses in the vertical flanges of the cassettes and in their concealed stiffeners attached on the rear face, so that they rest on the hanger supports and are screwed or riveted to the **STB-T-CH-PRO®** profiles.

The **STB-T-CH-PRO®** system complies with the main international certifications.

STB-T-CH-PRO® SYSTEM

SYSTEM COMPONENTS

INSULATING WEDGE AND GROOVE WASHER (1)

REF. 05.19.068 / 05.19.072 / 05.19.066

REF. 05.19.070

Optional insulating wedges and insulation covers, for eliminating thermal bridges in spacers.

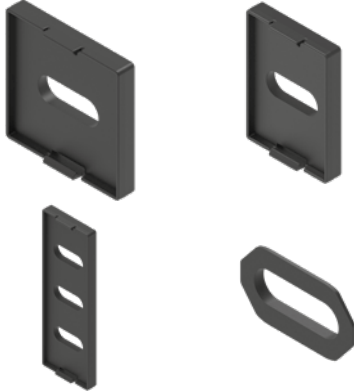

SPACER DOUBLE L

REF. 05.19.042 / 05.19.045

Designed to jointly connect two studs to the supporting wall.

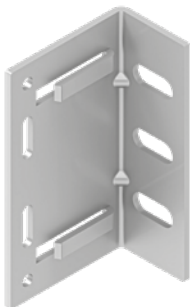

STB-T-CH-PRO® INTERMEDIATE L PROFILE (4)

REF. 05.19.120

In intermediate cassette position, for fixing the CH cassette and the **SHORT** horizontal stiffener support.



SPACER L (*) (2)

REF. 05.19.089 / 05.19.090 / 05.19.041/ 05.19.044 / 05.19.051 / 05.19.052 / 05.19.053 / 05.19.054 / 05.19.055 / 05.19.056

Designed to connect the studs to the supporting wall. Available in different sizes depending on the desired system thickness.

(*) Also available in stainless steel

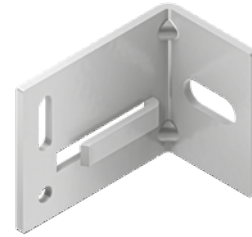

STB-T-CH-PRO® PROFILE (3)

REF. 05.19.092 / 05.19.093

In vertical joints between cassettes and intermediate position, for fixing T-CH-PRO® HANGER SUPPORT, CH cassette and **MINI** or **LONG** horizontal stiffener bracket.



STB-T-CH-PRO® HANGING BRACKET SET (5)

REF. 05.19.088

For hanging the CH cassettes to the substructure. Clipped to the STB-T-CH-PRO® profile for easy adjustment and fastened with 1 pre-installed central screw.

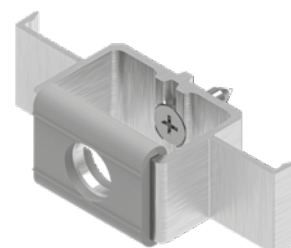

STB-T-CH-PRO® SYSTEM

SYSTEM COMPONENTS

CH CASSETTE LOWER CLIP

REF. 05.19.108

It is placed next to the intermediate profiles to fix the cassette on its lower part and to facilitate its alignment.



CH HORIZONTAL STIFFENING BRACKET (6)

REF. 05.19.105 / 05.19.106 / 05.19.109

Available in **LONG**, **SHORT** and **MINI** sizes, depending on the profile type on which it should be installed.

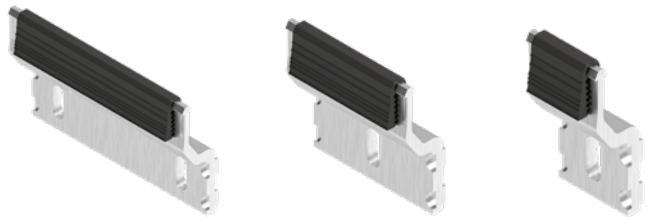

STIFFENING PROFILE (7)

REF. 05.19.107

It is fixed to the back of the cassette, fits on specific supports, and allows the execution of larger cassettes (width and height).

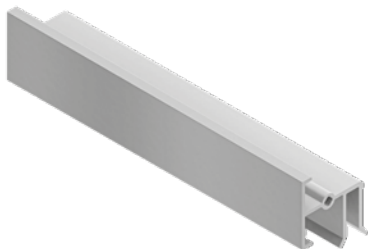

CASSETTE FORMING PLATE

REF. 05.19.050

It is used for forming, together with rivets, the corners of cassettes with 45 mm vertical flange.

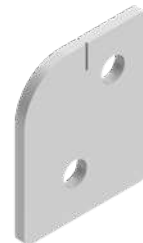

ANCHOR AND SCREW

REF. STB-T0800 / STB-T0801

For fixing the spacer to concrete or masonry. The specific load shall be checked by extraction test according to ETAG 020.



SEPARATOR / UPRIGHT FIXING SCREW

REF. STB-T0300 / STB-T0310 / STB-T0311 / STB-T0312

For fixing the upright to the spacer.



STB-T-CH-PRO® SYSTEM

SYSTEM COMPONENTS

SCREW FIXING TO UPRIGHT

REF. STB-T0600 / STB-T0610

For attaching **CH cassette**, **T-CH-PRO® HANGER SUPPORT**, or **CH HORIZONTAL STIFFENING BRACKET**, to the **T-OMEGA** or **L** profile.

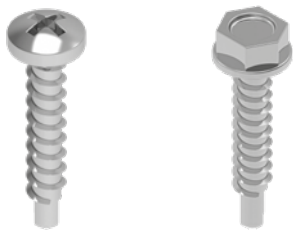

FLAT HEAD SCREW

REF. STB-T0700

For attaching stiffeners to the cassette at the ends.

(*) Possibility of delivery lacquered



FORMED RIVET (*)

REF. STB-R0300

For cassette forming.

(*) Possibility of delivery lacquered



STB-T-CH-PRO® SYSTEM

NEW COMPONENTS OF THE SYSTEM

The **STB-T-CH-PRO®** system cassettes are easier to machine than the STB-T-CH cassettes, as they incorporate fewer hooks.

Therefore, machining, forming and installation is faster and more economical.

UNFOLDED CASSETTE

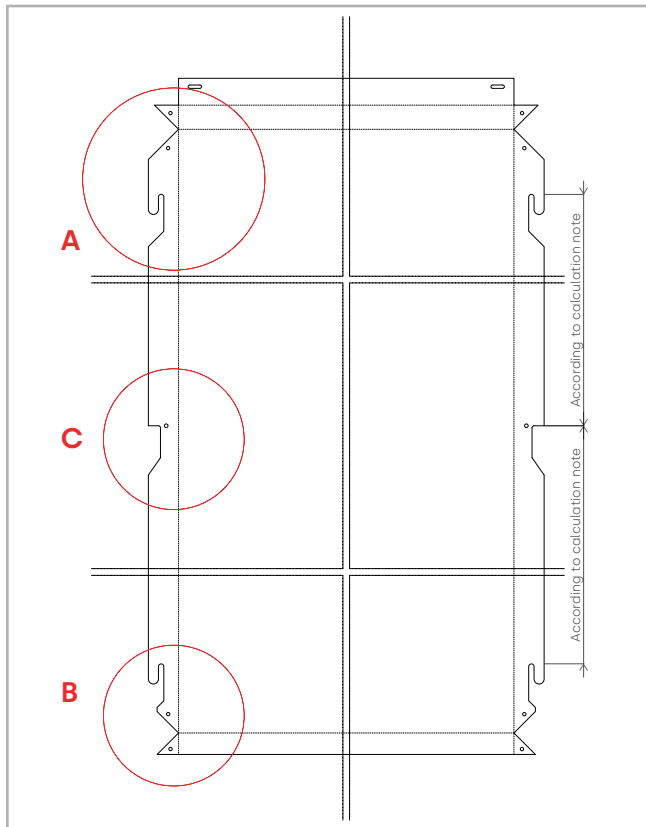

FORMED CASSETTE



DETAIL A

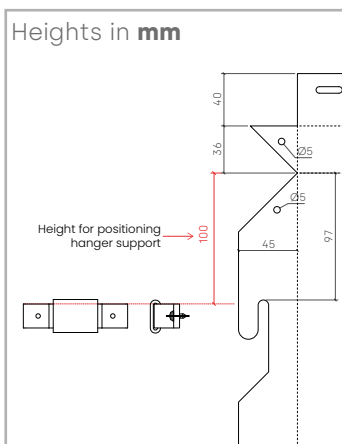

DETAIL B

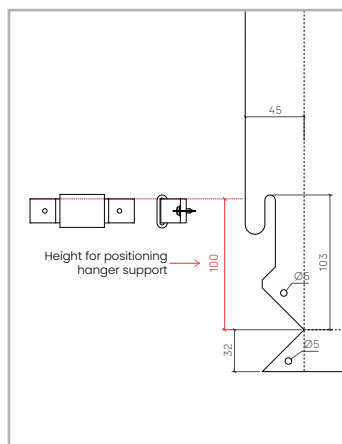

DETAIL C

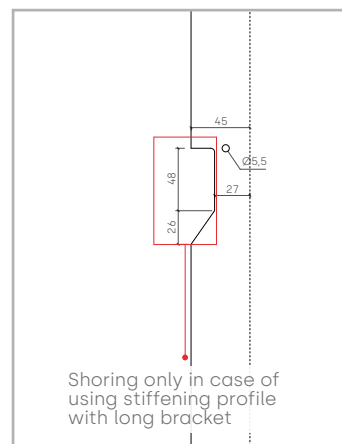

SEE CASSETTE FORMING VIDEO



EVOLUTION OF THE **STB-T-CH** SYSTEM to **STB-T-CH-PRO**®

NEW COMPONENTS OF THE SYSTEM

NEW **STB-T-CH-PRO**® HANGING BRACKET SET

When clipping the **STB-T-CH-PRO**® hanger support onto the profile, its height can be easily adjusted and thanks to the pre-installed screw already included in the part, it will be fixed easily, quickly and without damaging it.

Since the fastening screw is always accessible through the joint between the parts, the **STB-T-CH-PRO**® system allows positional corrections of the hangers even with the cassette installed, and facilitates their replacement without the need to dismantle the upper cassettes.

In addition, the **STB-T-CH-PRO**® system also simplifies the installation of end pieces and false ceilings.



New **STB-T-CH-PRO**® profile with integrated central screw guide.



New hanger support **STB-T-CH-PRO**® with built-in central fixing screw.



Top view and detail of the positioning of the hanger support on the profile **STB-T-CH-PRO**®.

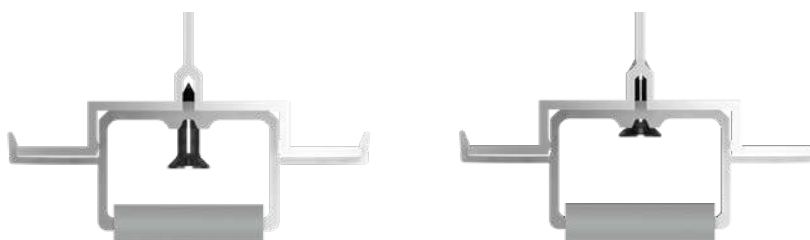

EVOLUTION OF THE STB-T-CH SYSTEM to STB-T-CH-PRO®

NEW COMPONENTS OF THE SYSTEM

NEW HORIZONTAL STIFFENER

The horizontal stiffener is an optional extruded aluminium profile, which allows the construction of large CH cassettes in both horizontal and vertical modulations.

The horizontal stiffener must be clipped into a set of custom single supports pre-fixed to all mullion profiles.

The use of these stiffeners not only eliminates the use of more expensive vertical stiffeners, but also allows the maximum spacing between studs to be increased.

With this new horizontal stiffener, the intermediate profiles can be executed with a lighter L-profile, fitted with the aforementioned stiffener supports instead of the classical T-OMEGA profiles with standard CH hangers, further increasing the savings in substructure.

The number of stiffeners to be placed will be indicated in the wind calculation note issued by the **STACBOND** technical office.

HORIZONTAL STIFFENER PLACEMENT



Clean the gluing area of the stiffener and cassette with a specific cleaner.

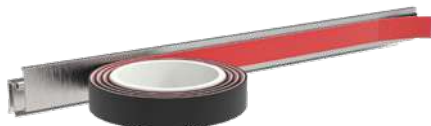

3M VHB Structural Tape 3M VHB GPH-160GF series* 1.6 mm thick and 25 mm wide.



*Bonding can also be carried out with elastic adhesive specific for this application.

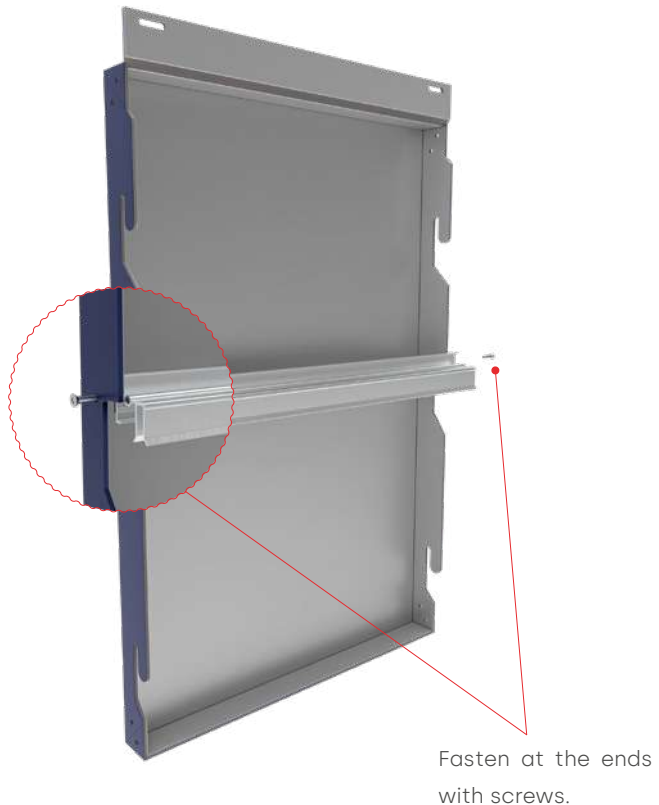
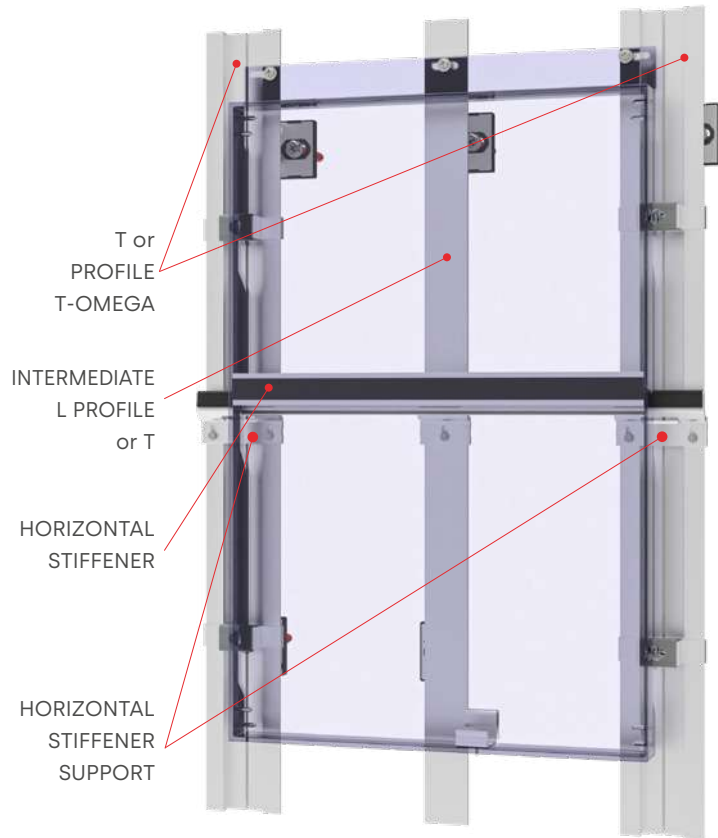

EVOLUTION OF THE **STB-T-CH** SYSTEM to **STB-T-CH-PRO®**

NEW COMPONENTS OF THE SYSTEM

NEW BOTTOM CLIP CH CASSETTE

The new bottom clip is placed on the **bottom flange** of the **CH cassette**, right next to the intermediate profiles, in order to fix the CH cassette at the bottom and facilitate its alignment.

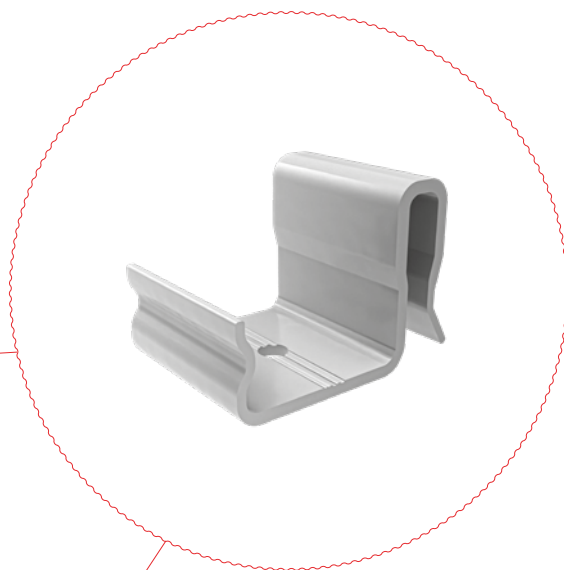
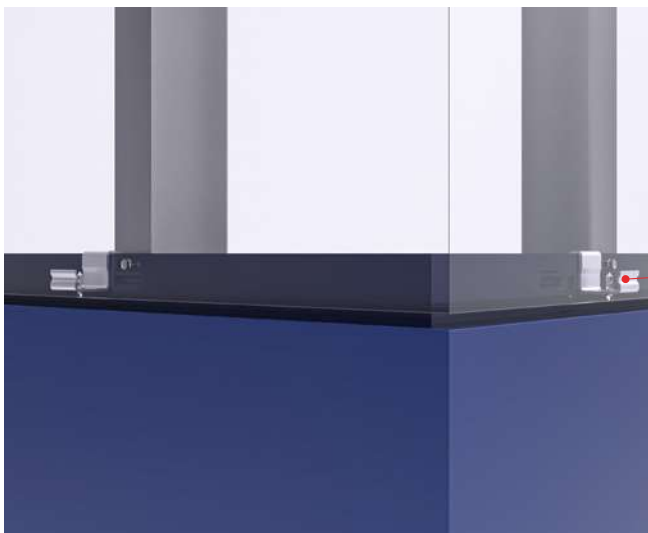

EVOLUTION OF THE STB-T-CH SYSTEM to STB-T-CH-PRO®

NEW FORMS OF MODULATION

HORIZONTAL AND VERTICAL MODULATIONS

Thanks to the placement of the stiffener, the PRO® system allows horizontal and vertical modulations.

In addition to the versatility in modulation, it allows a maximum spacing between vertical uprights of 1200 mm*, much wider than traditional CH.

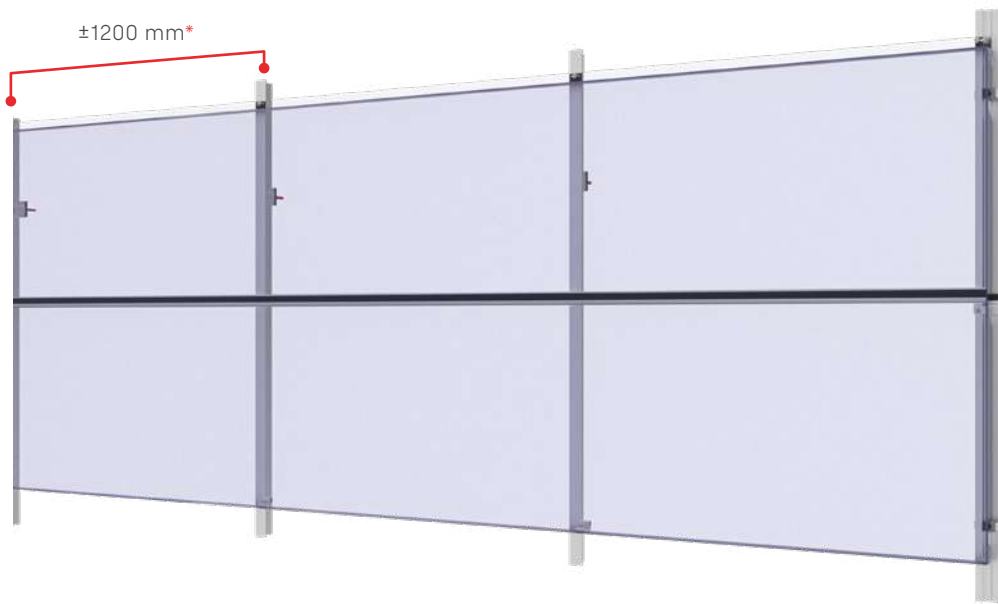

* Measurement to be consulted according to specific STACBOND calculation note.

SAVINGS IN MATERIALS



- Greater separation between uprights, allowing a saving in the amount of substructure to be used.
- Intermediate profiles T-OMEGA are replaced by more economical L-profiles*.
- The horizontal stiffener gluing system is more economical.

* Only at low wind loads

DETACHABLE AND REUSABLE

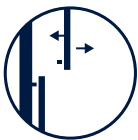

The adjustable hanger facilitates the positioning of the cassette and allows corrections with the cassette installed and the substitution of cassettes without the need to remove the upper cassettes.

FACADES WITHOUT LIMITS

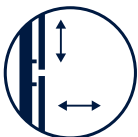

The placement of parts in false ceilings will be simpler and the vertical joint will be aesthetically cleaner thanks to the mini hanger.

INSULATING WEDGES

REF.	COMPONENT
05.19.066	INSULATING WEDGE FOR SPACERS DOUBLE L WITH REF: 05.19.042 / 05.19.045
05.19.068	INSULATING WEDGE FOR SPACERS L WITH REF: 05.19.053 / 05.19.054 / 05.19.055 / 05.19.056 / 05.19.082 / 05.19.083 / 05.19.084 / 05.19.085
05.19.072	INSULATING WEDGE FOR SPACERS L WITH REF: 05.19.041 / 05.19.044 / 05.19.051 / 05.19.052 / 05.19.078 / 05.19.079 / 05.19.080 / 05.19.081
05.19.070	3 x GROOVE WASHERS FOR SPACERS L WITH REF: 05.19.066 / 05.19.068 / 05.19.072

SPACERS

REF.	COMPONENT
05.19.041	SPACER L 68
05.19.044	SPACER L 92
05.19.051	SPACER L 116
05.19.052	SPACER L 140
05.19.053	SPACER L 164
05.19.054	SPACER L 188
05.19.055	SPACER L 212
05.19.056	SPACER L 236
05.19.078	SPACER INOX L 61
05.19.079	SPACER INOX L 85
05.19.080	SPACER INOX L 109
05.19.081	SPACER INOX L 133
05.19.082	SPACER INOX L 157
05.19.083	SPACER INOX L 181
05.19.084	SPACER INOX L 205
05.19.085	SPACER INOX L 229
05.19.042	SPACER DOUBLE L 68
05.19.045	SPACER DOUBLE L 92

PROFILES

REF.	COMPONENT
05.19.043	PROFILE T
05.19.059	PROFILE L INTERMEDIATE
05.19.092	STB-T-CH-PRO® PROFILE
05.19.093	STB-T-CH-PRO® SHORT PROFILE to be used with spacer L41 REF. 05.19.089 and spacer L51 REF. 05.19.090 only.

ADDITIONAL COMPONENTS

REF.	COMPONENT
05.19.088	STB-T-CH-PRO® HANGING BRACKET SET
05.19.108	CH CASSETTE LOWER CLIP
05.19.106	CH HORIZONTAL STIFFENER LONG BRACKET
05.19.105	CH HORIZONTAL STIFFENER SHORT BRACKET
05.19.109	CH HORIZONTAL STIFFENER MINI BRACKET
05.19.123	PIECE OF GASKET JOINT
05.19.107	STIFFENING PROFILE
05.19.050	CASSETTE FORMING PLATE

FIXING ACCESSORIES

REF.	COMPONENT
STB-T0800	ANCHOR + SCREW SET FOR FIXING BRACKET TO WALL X3 10X80 HEX. 3DG WIDE NECK
STB-T0801	ANCHOR + SCREW SET FOR FIXING BRACKET TO WALL SDF-KB-10X80-E A4 STAINLESS STEEL WIDE NECK
STB-T0300	SELF-TAPPING SCREW SDA5/3.5-6-H13-SA-5.5X20
STB-T0310	SLIDING POINT BRACKET-PROFILE FIXING SCREW JT9-2/5-5.0x25 VARIO STAINLESS STEEL A4
STB-T0311	DRILL BIT JT4-3H/5-5.5x19 INOX-A2 - FIXED POINT
STB-T0312	DRILL BIT JT9-3H/5-5.5x19 INOX-A4 - FIXED POINT
STB-T0600	SELF-DRILLING SCREW 4.2x19 STAINLESS STEEL A2 DIN 7504-N ROUNDED CYLINDRICAL HEAD
STB-T0610	SELF-DRILLING SCREW 4.2x19 STAINLESS STEEL A2 DIN 7504-K HEXAGONAL HEAD
STB-T0700	FLAT HEAD SCREW - 4,2x20
STB-R0300	ALU/SS RIVET Ø4.8X12, D.HEAD 9.5



See all available accessories on page 131

STB-T-CH-PRO® SYSTEM

TOTAL THICKNESS RATIO, ACCORDING TO SPACERS AND INSULATOR

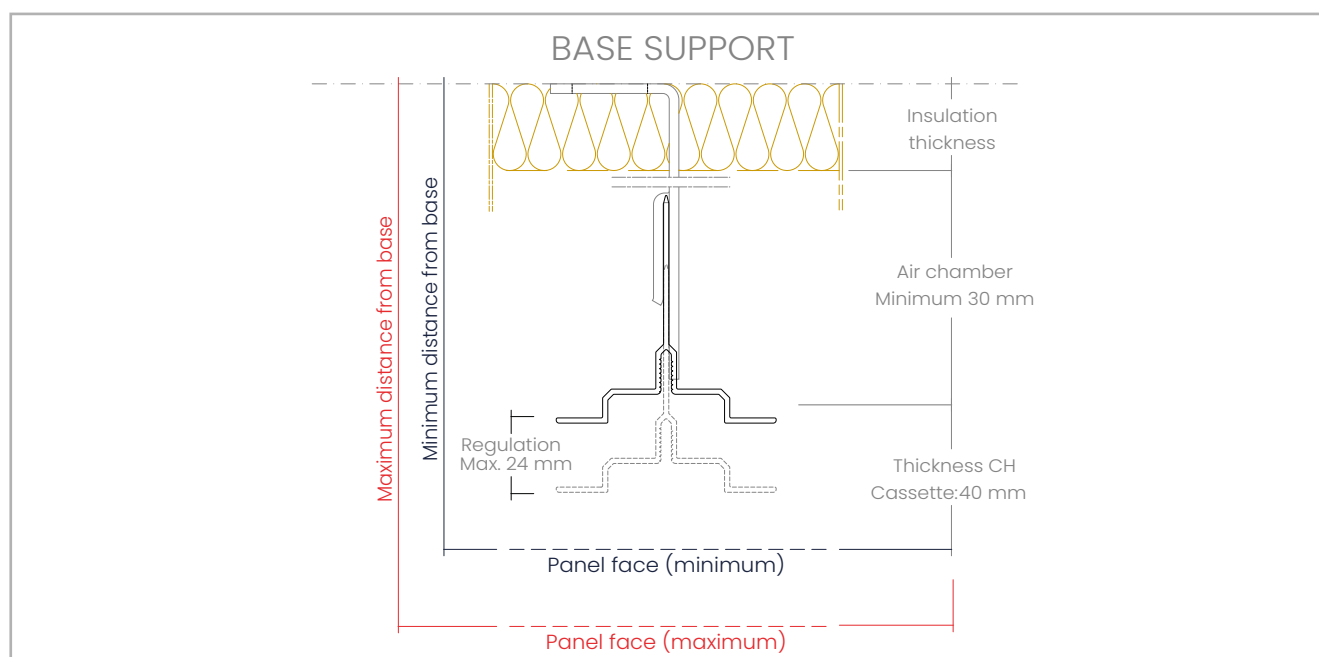

Note: the use of insulating wedges will increase the distance to the outer face of the panel by 5 mm.

SPACER L		DISTANCE (mm) FROM THE BASE OF THE ANCHORING TO EXPOSED PANEL FACE		INSULATING THICKNESS (mm) FOR 24 mm ADJUSTMENT*
REF.	COMPONENT	MINIMUM	MAXIMUM	MAXIMUM
05.19.089	SPACER L 41	110	120	with profile 05.19.093
05.19.090	SPACER L 51	120	130	with profile 05.19.093
05.19.090	SPACER L 51	130	137	—
05.19.041	SPACER L 68	137	161	—
05.19.044	SPACER L 92	161	185	40
05.19.051	SPACER L 116	185	209	60
05.19.052	SPACER L 140	209	233	80
05.19.053	SPACER L 164	233	257	110
05.19.054	SPACER L 188	257	281	130
05.19.055	SPACER L 212	281	305	160
05.19.056	SPACER L 236	305	329	180

SPACER INOX L		DISTANCE (mm) FROM THE BASE OF THE ANCHORING TO EXPOSED PANEL FACE		INSULATING THICKNESS (mm) FOR 24 mm ADJUSTMENT*
REF.	COMPONENT	MINIMUM	MAXIMUM	MAXIMUM
05.19.078	SPACER INOX L 61	132	156	—
05.19.079	SPACER INOX L 85	156	180	30
05.19.080	SPACER INOX L 109	180	204	60
05.19.081	SPACER INOX L 133	204	228	80
05.19.082	SPACER INOX L 157	228	252	100
05.19.083	SPACER INOX L 181	252	276	130
05.19.084	SPACER INOX L 205	276	300	150
05.19.085	SPACER INOX L 229	300	324	180

SPACER DOUBLE L		DISTANCE (mm) FROM THE BASE OF THE ANCHORING TO EXPOSED PANEL FACE		INSULATING THICKNESS (mm) FOR 24 mm ADJUSTMENT*
REF.	COMPONENT	MINIMUM	MAXIMUM	MAXIMUM
05.19.042	SPACER DOUBLE L 68	137	161	—
05.19.045	SPACER DOUBLE L 92	161	185	40

* For the calculation of the maximum admissible thickness, rigid insulation has been taken into account, guaranteeing the maximum regulation of each system and maintaining an air gap of ≥ 30 mm.

STB-T-SZ

MALE-FEMALE SYSTEM

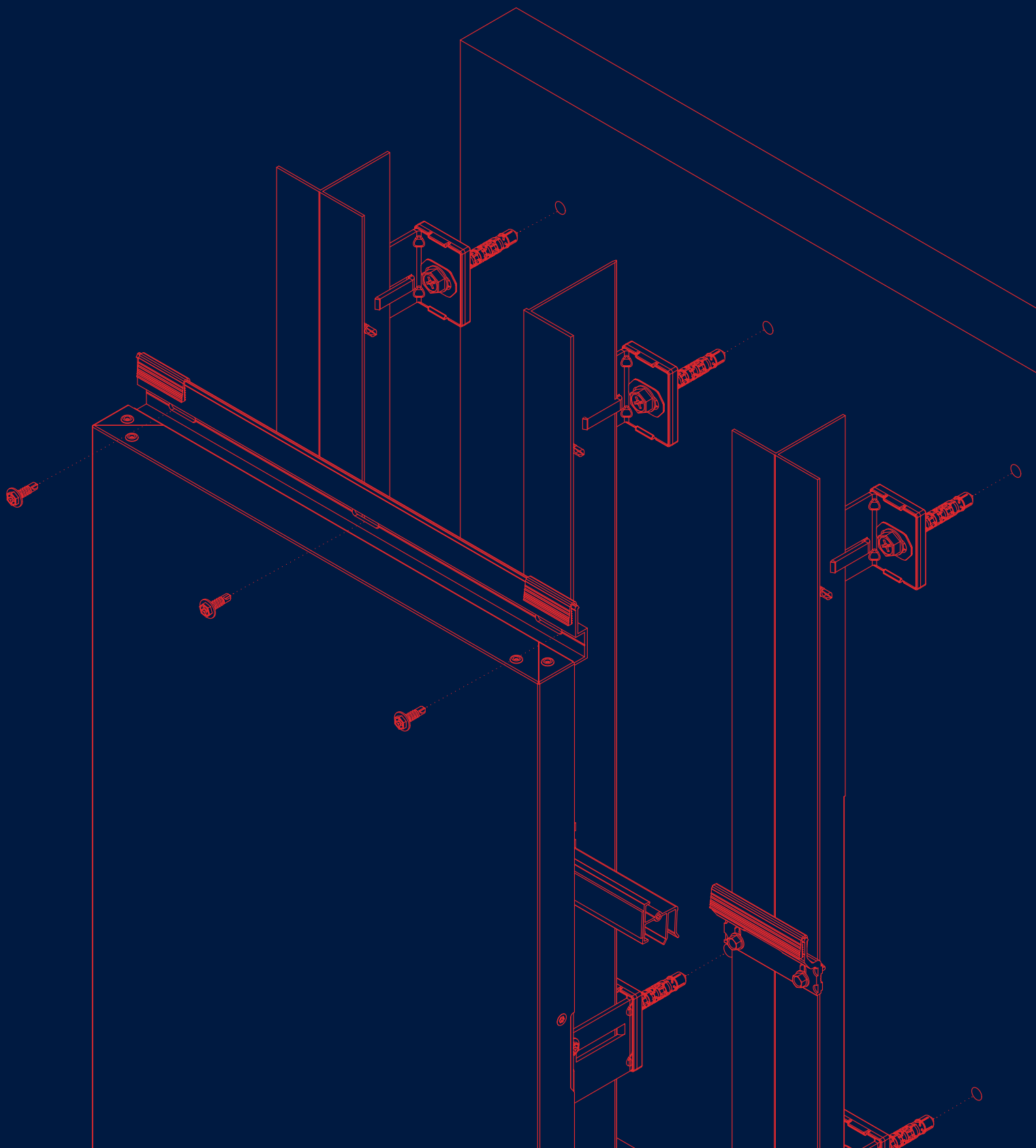

STB-T-SZ SYSTEM

DESCRIPTION

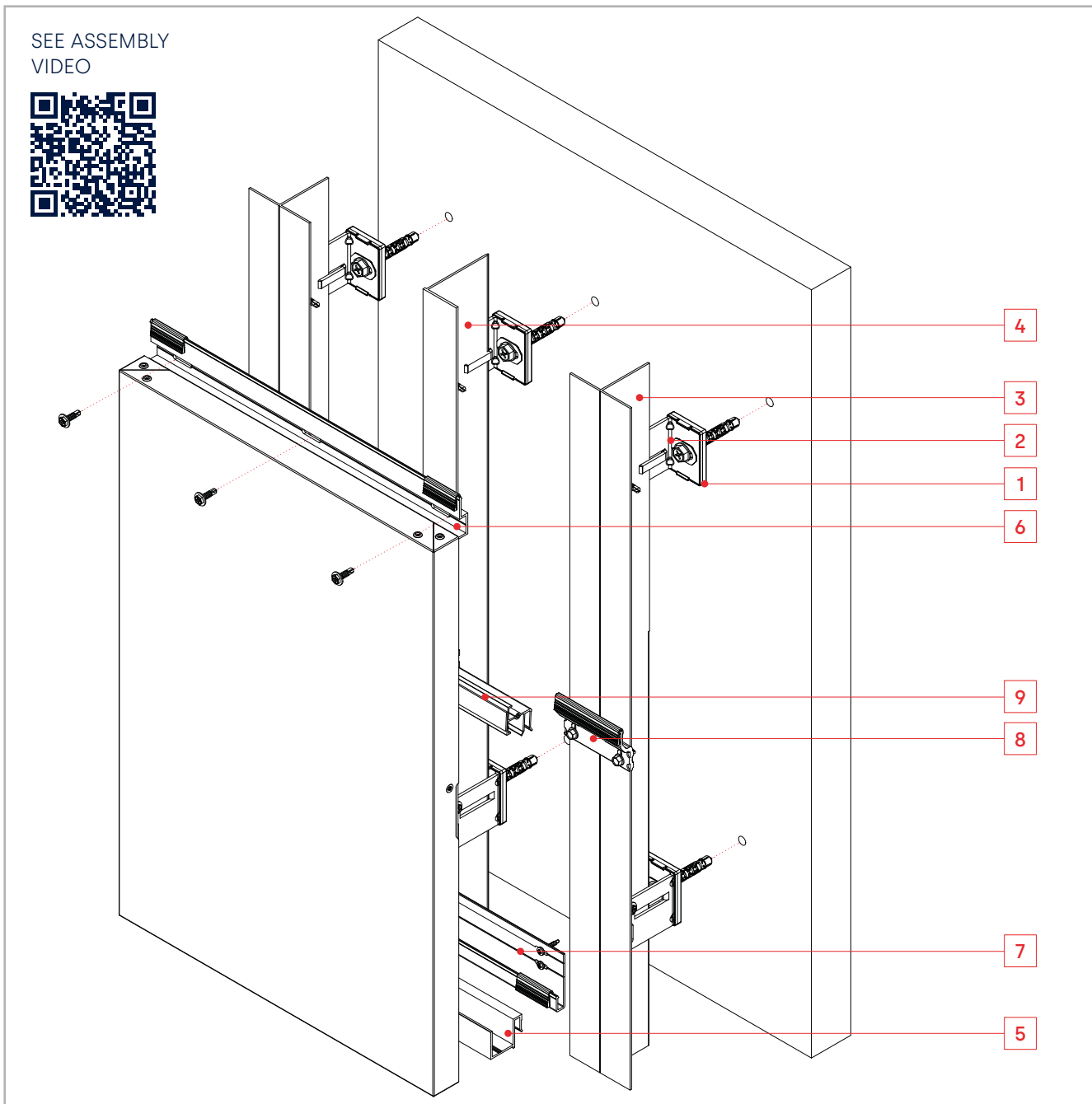

The **STB-T-SZ** is a kit system based on **STACBOND composite panel cassettes for the assembly of ventilated façades**. It is a tongue and groove system with concealed fixing, versatile and quick to assemble, specially designed to develop façades with horizontal or vertical modulation, with predominantly blind parts and/or little surface area of openings or linear openings.

This system also allows us to execute curved cassettes. It consists of two 6063 T5/T6 aluminium alloy profiles 6063 T5/T6 on which the already formed cassettes are anchored:

- Lower female profile, so-called **S-profile**.
- Upper male profile, so-called **Z-profile**.

The substructure is composed of **L-spacers** (alloy 5005 H24 or INOX AISI 304/430) and **T, L or profiles T-OMEGA** (alloy 6063 T5/T6).

These spacers have different lengths to accommodate the required thickness of thermal insulation and to absorb all the irregularities of the façade. For the thermal bridge break, **STAC** has developed specific **INSULATING WEDGES** to be placed between the spacers L and the wall facing.

INSULATING WEDGE AND GROOVE WASHER (1)

REF. 05.19.068 / 05.19.072 / 05.19.066

REF. 05.19.070

Optional insulating wedges and insulation covers, for eliminating thermal bridges in spacers.

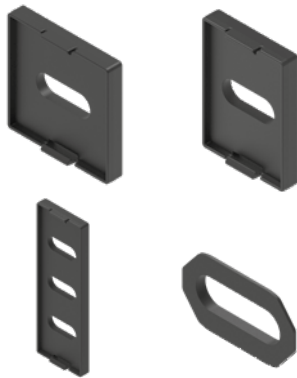

SPACER DOUBLE L

REF. 05.19.042 / 05.19.045

Designed to jointly connect two studs to the supporting wall.

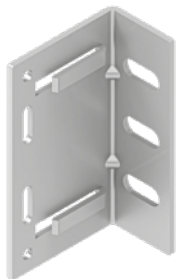

PROFILE L INTERMEDIATE (4)

REF. 05.19.059

In the intermediate position of the cassettes, for the attachment of SZ cassette, and **SHORT** horizontal stiffener bracket.



SPACER L (*) (2)

REF. 05.19.041/ 05.19.044 / 05.19.051 / 05.19.052 / 05.19.053 / 05.19.054 / 05.19.055 / 05.19.056

Designed to connect the studs to the supporting wall. Available in different sizes depending on the desired system thickness.

(*) Also available in stainless steel

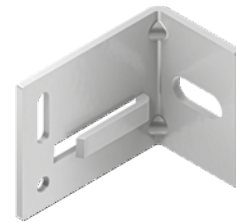

PROFILE T (3)

REF. 05.19.043

In vertical joints between cassettes and intermediate position, for fixing of SZ cassette, and **LONG** support of horizontal stiffener.



PROFILE T-OMEGA

REF. 05.19.061

In vertical joints between cassettes and intermediate position, for fixing of SZ cassette, and **MINI** horizontal stiffener bracket.



STB-T-SZ SYSTEM

SYSTEM COMPONENTS

S PROFILE (5)

REF. 05.19.121

It is installed in the lower part of the SZ cassette.

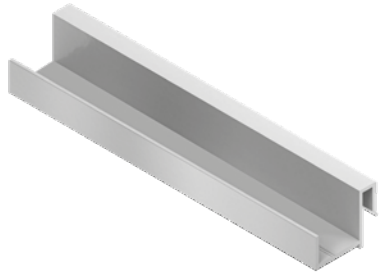

Z PROFILE (6)

REF. 05.19.122

It is installed on top of the SZ cassette.

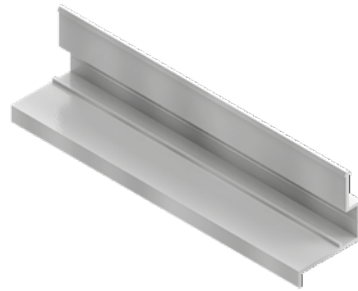

STARTER PROFILE (7)

REF. 05.19.099

To support the first cassette at the foot of the façade.

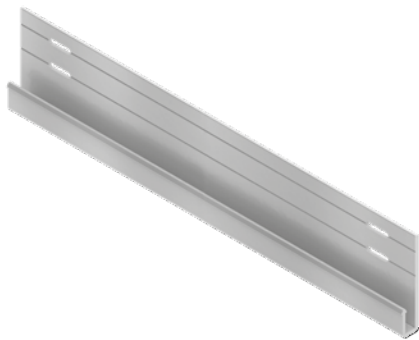

SZ HORIZONTAL STIFFENER BRACKET (8)

REF. 05.19.101 / 05.19.100 / 05.19.110

Available in **LONG**, **SHORT** and **MINI** sizes, depending on the profile type on which it should be installed.

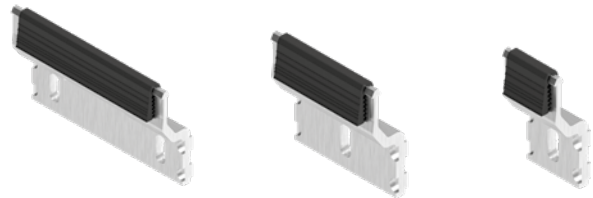

PIECE OF GASKET JOINT

REF. 05.19.129

To be fitted to starter profiler and Z-profile.



STIFFENING PROFILE (9)

REF. 05.19.107

It is fixed to the back of the cassette, fits on specific supports, and allows for larger cassettes (width and height), which are fully removable and reusable.

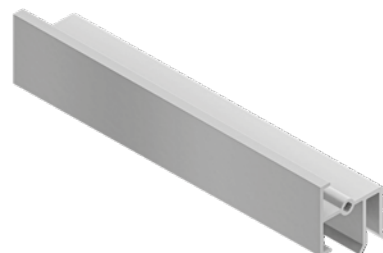

REINFORCEMENT STB-T-SZ

REF. 05.19.049

It is fixed to the vertical upright and glued to the rear face of the cassette so that higher cassettes can be made.



SEPARATOR / UPRIGHT FIXING SCREW

REF. STB-T0300 / STB-T0310 / STB-T0311 / STB-T0312

For fixing the upright to the spacer.



FLAT HEAD SCREW (*)

REF. STB-T0700

For fixing stiffeners to the ends of the cassette.

(*) Possibility of delivery lacquered



ANCHOR AND SCREW

REF. STB-T0800 / STB-T0801

For fixing spacer to concrete or masonry. The specific load shall be checked by extraction test according to ETAG 020.



SCREW FIXING TO UPRIGHT

REF. STB-T0600 / STB-T0610

For attaching the SZ cassette, SZ HORIZONTAL STIFFENING SUPPORT, and STARTER PROFILE to the T, L or PROFILE T-OMEGA.

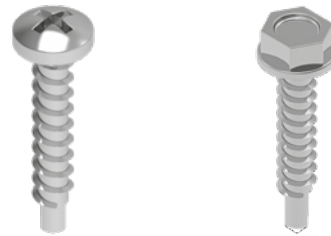

FORMED RIVET (*)

REF. STB-R0300

For cassette forming.

(*) Possibility of delivery lacquered



STB-T-SZ SYSTEM

STANDARD SZ CASSETTE

The standard cassettes of the **STB-T-SZ** system have 30 mm flanges. They are mechanically fastened by means of rivets directly onto the longitudinal profiles S and Z for forming.

The **S-profile** is placed at the bottom and the **Z-profile** at the top of the cassette. The profiles provide high longitudinal rigidity to the cassettes.

UNFOLDED CASSETTE

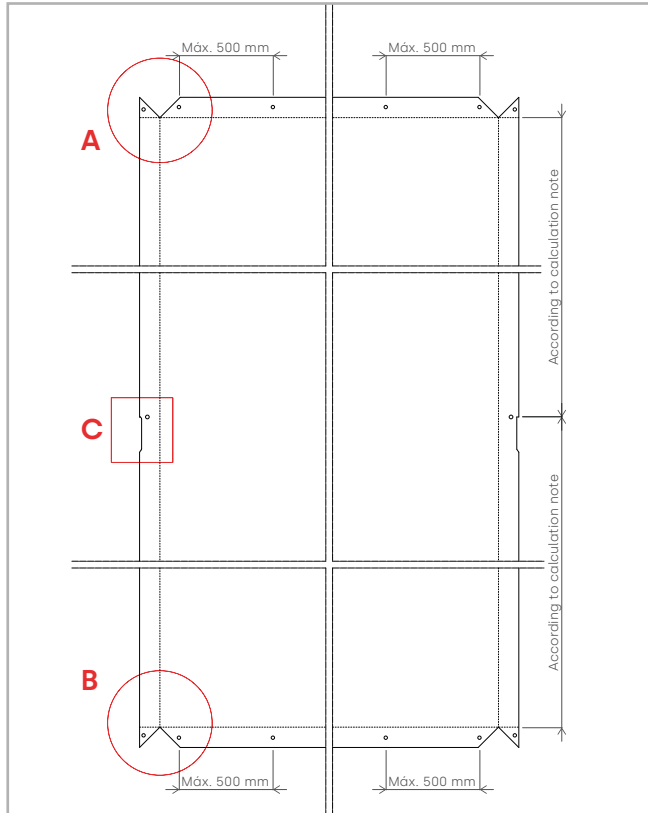

FORMED CASSETTE



DETAIL A

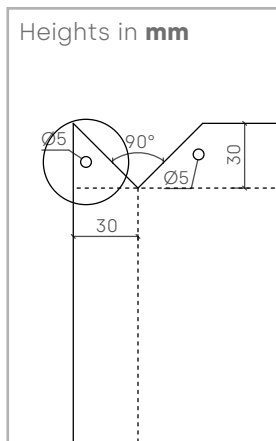

DETAIL B

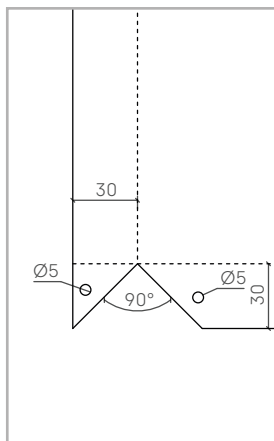

DETAIL C

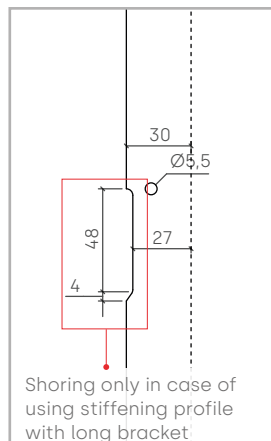

SEE CASSETTE
FORMING
VIDEO



STARTER PROFILE AND CLOG REMOVER

The co-extruded gap seal is easily installed in the **Z-profile** and the **starter profile**, with a maximum gap of 500 mm between them.

This avoids possible vibrations between cassettes, and facilitates the adjustment of cassettes to ensure the correct levelling of the pieces.

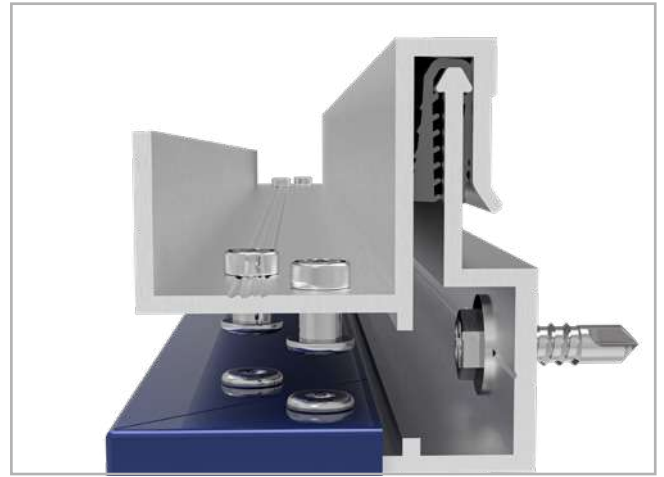
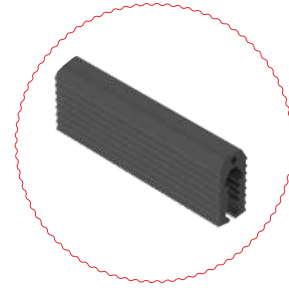

USE OF STB-T-SZ REINFORCEMENT

The use of STB-T-SZ reinforcement varies depending on the height of the cassette and the wind load of the project site.

It is required to be used on each of the mullion profiles to which the composite panel cassette is attached.

The STB-T-SZ reinforcement is fixed to the **T or profile L intermediate**, using rivets, and double-sided tape and specific adhesive is applied to the front face of the reinforcement.

Subsequently, the cassette is placed, which **is adhered to the reinforcement** on the back side.

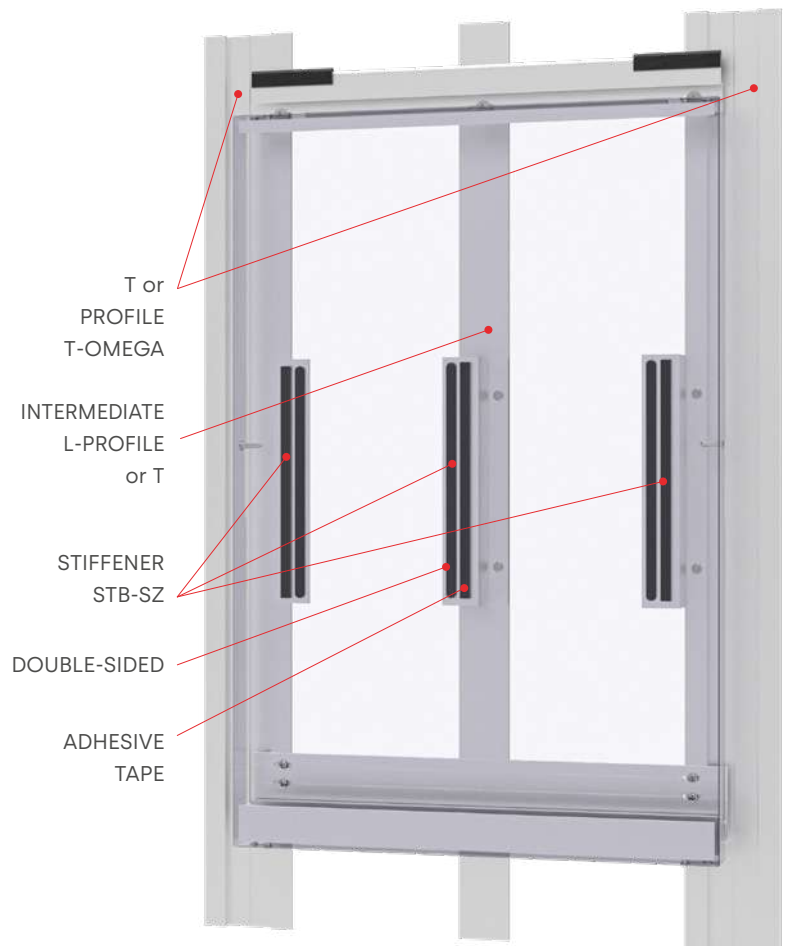

The number of STB-T-SZ reinforcements to be installed will be indicated in the wind calculation note issued by the **STACBOND** technical office.

EVOLUTION OF THE **STB-T-SZ** SYSTEM to **STB-T-SZ evo®**

NEW COMPONENTS OF THE SYSTEM

NEW HORIZONTAL STIFFENER

The horizontal stiffener is an optional extruded aluminium profile, which allows the construction of **large-sized SZ cassettes in both horizontal and vertical modulations, and allowing the free disassembly of the cassette and its subsequent reuse** (unlike the cassettes in which the STB-T-SZ reinforcement is used).

The horizontal stiffener must be clipped into the horizontal SZ stiffening brackets, which are pre-fixed to all mullion profiles.

The use of these stiffeners not only **improves the versatility of the STB-T-SZ system**, but also allows the **maximum spacing between uprights** to be **increased** compared to a system without stiffeners or with STB-T-SZ reinforcements.

The number of stiffeners to be placed will be indicated in the wind calculation note issued by the **STACBOND** technical office.

HORIZONTAL STIFFENER PLACEMENT



Clean the gluing area of the stiffener and cassette with a specific cleaner.

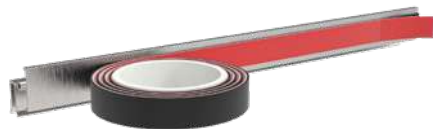

3M VHB Structural Tape 3M VHB GPH-160GF series* 1.6 mm thick and 25 mm wide.



*Bonding can also be carried out with elastic adhesive specific for this application.

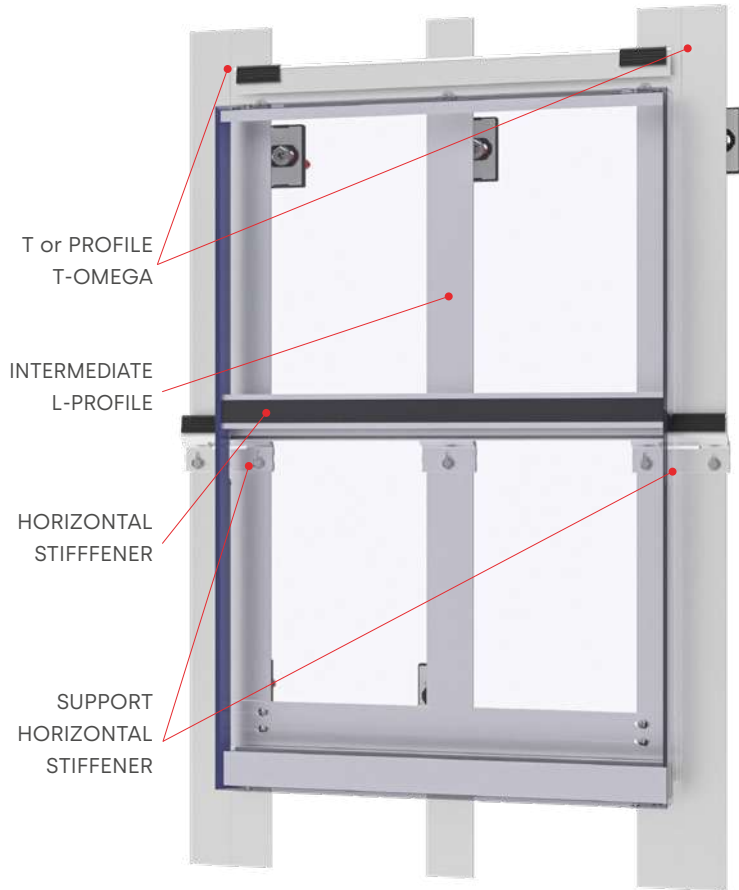

 System compatible with Omega substructure.

Fasten at the ends with screws.



EVOLUTION OF THE **STB-T-SZ** SYSTEM to **STB-T-SZ evo®**

NEW FORMS OF MODULATION

HORIZONTAL AND VERTICAL MODULATIONS

Thanks to the placement of the stiffener, the **evo®** system allows horizontal and vertical modulations, with fully **removable** and **reusable** cassettes.

In addition to the versatility in modulation, it **allows a maximum spacing between vertical stanchions of 1200 mm***, much wider than traditional SZ.



*Measurement to be consulted according to specific STACBOND calculation note.



SAVINGS IN MATERIALS

New, lighter and more efficient S-profile, Z-profile and starter profile.

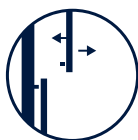

DETACHABLE AND REUSABLE

The cassettes can be easily replaced thanks to the horizontal stiffener.

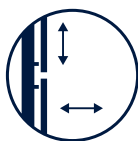

FACADES WITHOUT LIMITS

Designed for the execution of façades with horizontal or vertical modulation.

STB-T-SZ SYSTEM

REFERENCE LIST

INSULATING WEDGES

REF.	COMPONENT
05.19.066	INSULATING WEDGE FOR SPACERS DOUBLE L WITH REF: 05.19.042 / 05.19.045
05.19.068	INSULATING WEDGE FOR SPACERS L WITH REF: 05.19.053 / 05.19.054 / 05.19.055 / 05.19.056 / 05.19.082 / 05.19.083 / 05.19.084 / 05.19.085
05.19.072	INSULATING WEDGE FOR SPACERS L WITH REF: 05.19.041 / 05.19.044 / 05.19.051 / 05.19.052 / 05.19.078 / 05.19.079 / 05.19.080 / 05.19.081
05.19.070	3 x GROOVE WASHERS FOR SPACERS L WITH REF: 05.19.066 / 05.19.068 / 05.19.072

SPACERS

REF.	COMPONENT
05.19.041	SPACER L 68
05.19.044	SPACER L 92
05.19.051	SPACER L 116
05.19.052	SPACER L 140
05.19.053	SPACER L 164
05.19.054	SPACER L 188
05.19.055	SPACER L 212
05.19.056	SPACER L 236
05.19.078	SPACER INOX L 61
05.19.079	SPACER INOX L 85
05.19.080	SPACER INOX L 109
05.19.081	SPACER INOX L 133
05.19.082	SPACER INOX L 157
05.19.083	SPACER INOX L 181
05.19.084	SPACER INOX L 205
05.19.085	SPACER INOX L 229
05.19.042	SPACER DOUBLE L 68
05.19.045	SPACER DOUBLE L 92

PROFILES

REF.	COMPONENT
05.19.043	PROFILE T
05.19.059	PROFILE L INTERMEDIATE
05.19.061	PROFILE T-OMEGA
05.19.121	S PROFILE
05.19.122	Z PROFILE
05.19.099	STARTER PROFILE

ADDITIONAL COMPONENTS

REF.	COMPONENT
05.19.101	SZ HORIZONTAL STIFFENER LONG BRACKET
05.19.100	SZ HORIZONTAL STIFFENER SHORT BRACKET
05.19.110	SZ HORIZONTAL STIFFENER MINI BRACKET
05.19.123	PIECE OF GASKET JOINT
05.19.107	STIFFENING PROFILE
05.19.049	REINFORCEMENT STB-T-SZ

FIXING ACCESSORIES

REF.	COMPONENT
STB-T0800	ANCHOR + SCREW SET FOR FIXING BRACKET TO WALL X3 10X80 HEX. 3DG WIDE NECK
STB-T0801	ANCHOR + SCREW SET FOR FIXING BRACKET TO WALL SDF-KB-10X80-E A4 STAINLESS STEEL WIDE NECK
STB-T0300	SELF-TAPPING SCREW SDA5/3.5-6-H13-SA-5.5X20
STB-T0310	SLIDING POINT BRACKET-PROFILE FIXING SCREW JT9-2/5-5.0x25 VARIO STAINLESS STEEL A4
STB-T0311	DRILL BIT JT4-3H/5-5.5x19 INOX-A2 - FIXED POINT
STB-T0312	DRILL BIT JT9-3H/5-5.5x19 INOX-A4 - FIXED POINT
STB-T0600	SELF-DRILLING SCREW 4.2x19 STAINLESS STEEL A2 DIN 7504-N ROUNDED CYLINDRICAL HEAD
STB-T0610	SELF-DRILLING SCREW 4.2x19 STAINLESS STEEL A2 DIN 7504-K HEXAGONAL HEAD
STB-T0700	FLAT HEAD SCREW - 4,2x20
STB-R0300	ALU/SS RIVET Ø4.8X12, D.HEAD 9.5



See all available accessories on page 131

STB-T-SZ SYSTEM

TOTAL THICKNESS RATIO, ACCORDING TO SPACERS AND INSULATOR

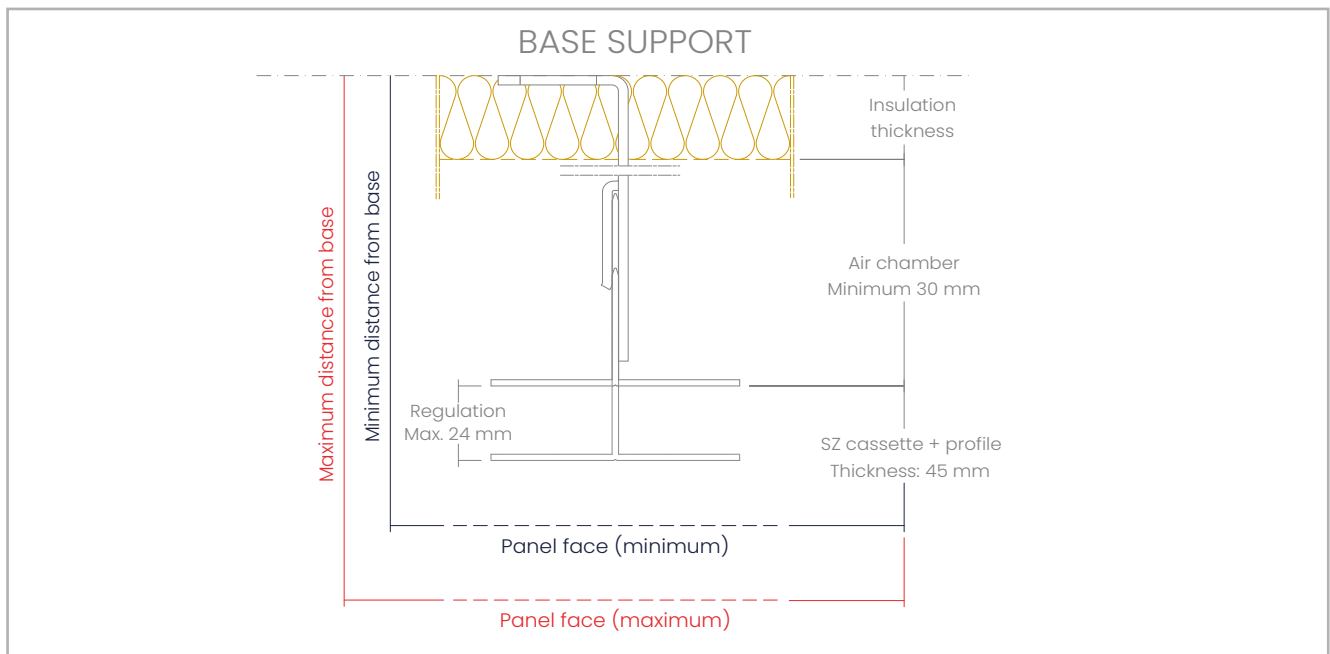

Note: the use of insulating wedges will increase the distance to the outer face of the panel by 5 mm.

SPACER L		DISTANCE (mm) FROM THE BASE OF THE ANCHORING TO EXPOSED PANEL FACE		INSULATING THICKNESS (mm) FOR 24 mm REGULATION*
REF.	COMPONENT	MINIMUM	MAXIMUM	MAXIMUM
05.19.041	SPACER L 68	121	145	—
05.19.044	SPACER L 92	145	169	40
05.19.051	SPACER L 116	169	193	60
05.19.052	SPACER L 140	193	217	80
05.19.053	SPACER L 164	217	241	110
05.19.054	SPACER L 188	241	265	130
05.19.055	SPACER L 212	265	289	160
05.19.056	SPACER L 236	289	313	180

SPACER INOX L		DISTANCE (mm) FROM THE BASE OF THE ANCHORING TO EXPOSED PANEL FACE		INSULATING THICKNESS (mm) FOR 24 mm REGULATION*
REF.	COMPONENT	MINIMUM	MAXIMUM	MAXIMUM
05.19.078	SPACER INOX L 61	116	140	—
05.19.079	SPACER INOX L 85	140	164	30
05.19.080	SPACER INOX L 109	164	188	60
05.19.081	SPACER INOX L 133	188	212	80
05.19.082	SPACER INOX L 157	212	236	100
05.19.083	SPACER INOX L 181	236	260	130
05.19.084	SPACER INOX L 205	260	284	150
05.19.085	SPACER INOX L 229	284	308	180

SPACER DOUBLE L		DISTANCE (mm) FROM THE BASE OF THE ANCHORING TO EXPOSED PANEL FACE		INSULATING THICKNESS (mm) FOR 24 mm REGULATION*
REF.	COMPONENT	MINIMUM	MAXIMUM	MAXIMUM
05.19.042	SPACER DOUBLE L 68	121	145	—
05.19.045	SPACER DOUBLE L 92	145	169	40

*For the calculation of the maximum admissible thickness, rigid insulation has been taken into account, guaranteeing the maximum regulation of each system and maintaining an air gap of ≥ 30 mm.

STACBOND
more than you see

STB-T-SZ-PRO[®]

MALE-FEMALE SYSTEM

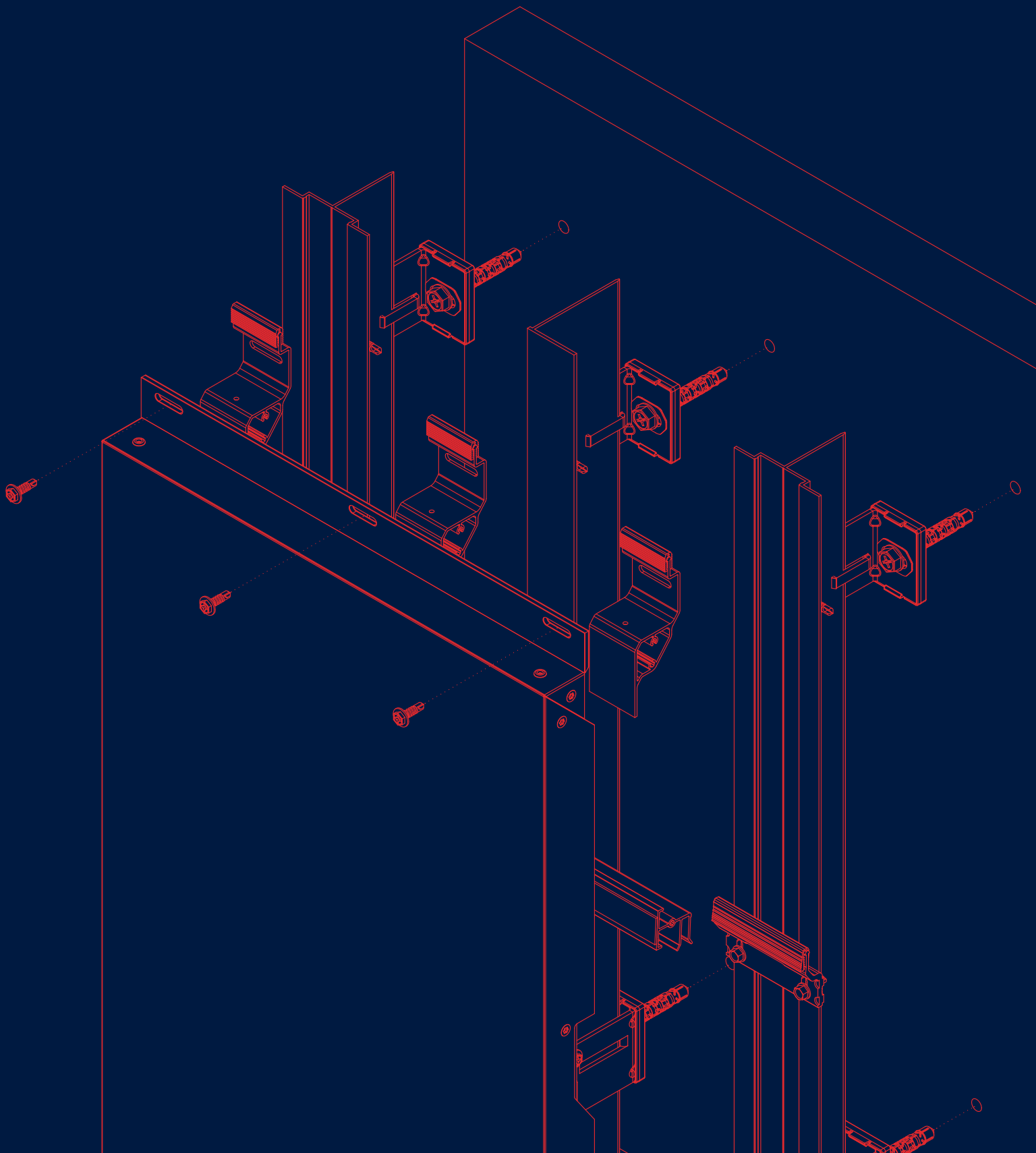

STB-T-SZ-PRO® SYSTEM

DESCRIPTION

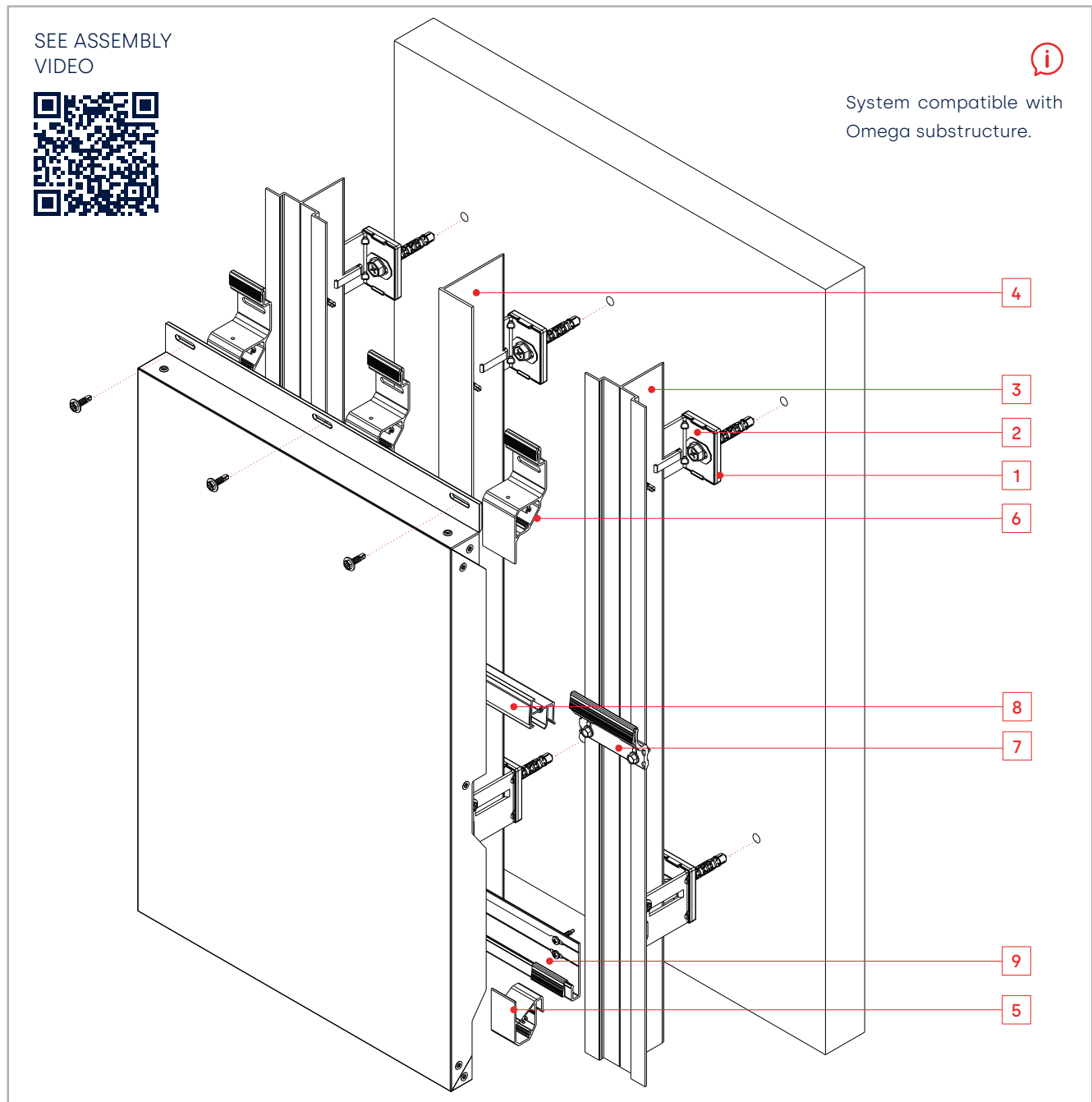

The **STB-T-SZ-PRO®** is a kit system based on **STACBOND composite panel cassettes for the assembly of ventilated façades**. It is a tongue and groove system with concealed fixing, versatile and quick to assemble, specially designed to develop façades with horizontal or vertical modulation, with predominantly blind parts and/or little surface area of openings or linear openings.

It consists of two 6063 T5/T6 aluminium alloy profiles 6063 T5/T6 on which the already formed cassettes are anchored:

- Lower female bracket, so-called **S-bracket**.
- Upper male bracket, so-called **Z-bracket**.

The substructure is composed of **L-spacers** (alloy 5005 H24 or INOX AISI 304/430) and **T, L or profiles T-OMEGA** (alloy 6063 T5/T6).

These spacers have different lengths to accommodate the required thickness of thermal insulation and to absorb all the irregularities of the façade. For the thermal bridge break, **STAC** has developed specific **INSULATING WEDGES** to be placed between the spacers L and the wall facing.

INSULATING WEDGE AND GROOVE WASHER (1)

REF. 05.19.068 / 05.19.072 / 05.19.066

REF. 05.19.070

Optional insulating wedges and insulation covers, for eliminating thermal bridges in spacers.

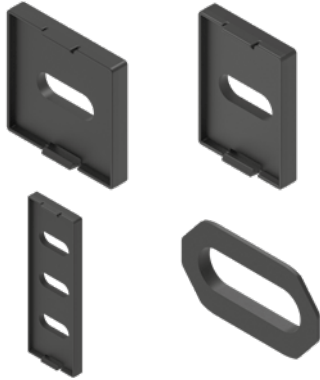

SPACER DOUBLE L

REF. 05.19.042 / 05.19.045

Designed to jointly connect two studs to the supporting wall.

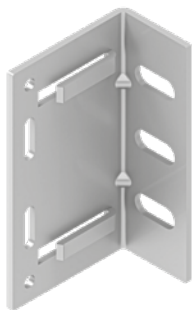

PROFILE L INTERMEDIATE (4)

REF. 05.19.059

In the intermediate position of the cassettes, for the attachment of SZ cassette, and **SHORT** horizontal stiffener support.



SPACER L (*) (2)

REF. 05.19.041/ 05.19.044 / 05.19.051 / 05.19.052 / 05.19.053 / 05.19.054 / 05.19.055 / 05.19.056

Designed to connect the studs to the supporting wall. Available in different sizes depending on the desired system thickness.

(*) Also available in stainless steel

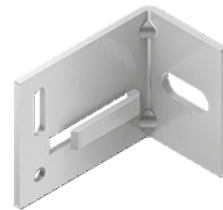

PROFILE T-OMEGA (3)

REF. 05.19.061

In vertical joints between cassettes, for fixing of SZ cassette, and **MINI or LONG** support of horizontal stiffener.



PROFILE T

REF. 05.19.043

In vertical joints between cassettes, for fixing of SZ cassette, and **LONG** horizontal stiffener support.



STB-T-SZ-PRO® SYSTEM

SYSTEM COMPONENTS

S-BRACKET (5)

REF. 05.19.096 / 05.19.097

Available in **SHORT** and **LONG** sizes. It is installed in the lower part of the SZ cassette.

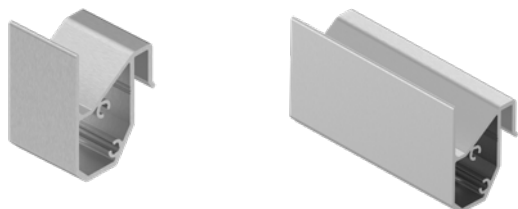

Z-BRACKET (6)

REF. 05.19.094 / 05.19.095

Available in **SHORT** and **LONG** sizes. It is installed on top of the SZ cassette.

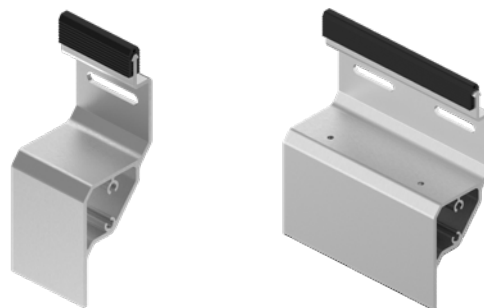

STARTER PROFILE

REF. 05.19.099

To support the first cassette at the foot of the façade.

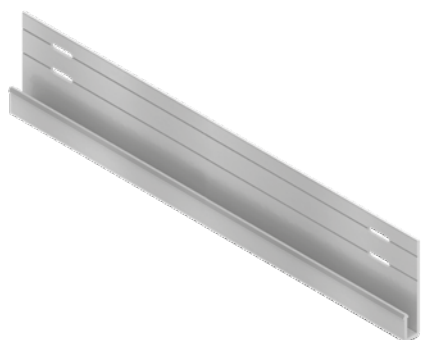

SZ HORIZONTAL STIFFENER BRACKET (7)

REF. 05.19.101 / 05.19.100 / 05.19.110

Available in **LONG**, **SHORT** and **MINI** sizes, depending on the profile type on which it should be installed.

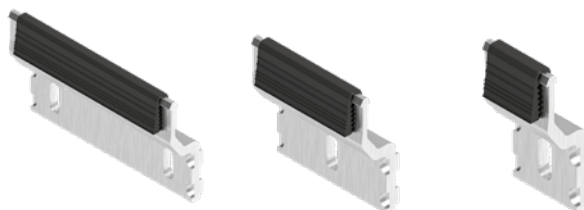

PIECE OF GASKET JOINT

REF. 05.19.129

To be fitted to starter profile.



STIFFENING PROFILE (8)

REF. 05.19.107

It is fixed to the back of the cassette, fits on specific supports, and allows for larger cassettes (width and height), which are fully removable and reusable.

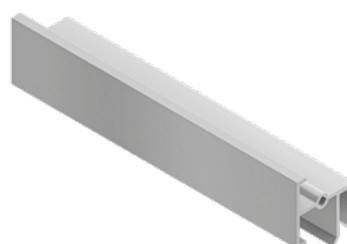

SEPARATOR / UPRIGHT FIXING SCREW

REF. STB-T0300 / STB-T0310 / STB-T0311 / STB-T0312

For fixing the upright to the spacer.



SCREW FIXING TO UPRIGHT

REF. STB-T0600 / STB-T0610

For attaching the SZ-PRO®, **SZ HORIZONTAL STIFFENING SUPPORT**, and **STARTER PROFILE** to the T, L or PROFILE T-OMEGA.

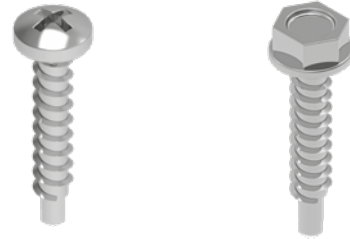

FLAT HEAD SCREW (*)

REF. STB-T0700

For attaching end stiffeners to the cassette.

(*) Possibility of delivery lacquered



STB-T-SZ-PRO[®] SYSTEM

STANDARD NARROW BRIM SZ CASSETTE

STB-T-SZ-PRO[®] standard tray panels are easier to machine than CH system ones. Forming becomes also a simpler task since it is carried out using screws directly fixed to S and Z mounting brackets.

The **S-shaped bracket** is placed at the bottom whilst the **Z-shaped bracket** at the top of each tray panel.

These custom mounting brackets save significant amounts of profile compared to conventional SZ systems.

UNFOLDED CASSETTE

FORMED CASSETTE

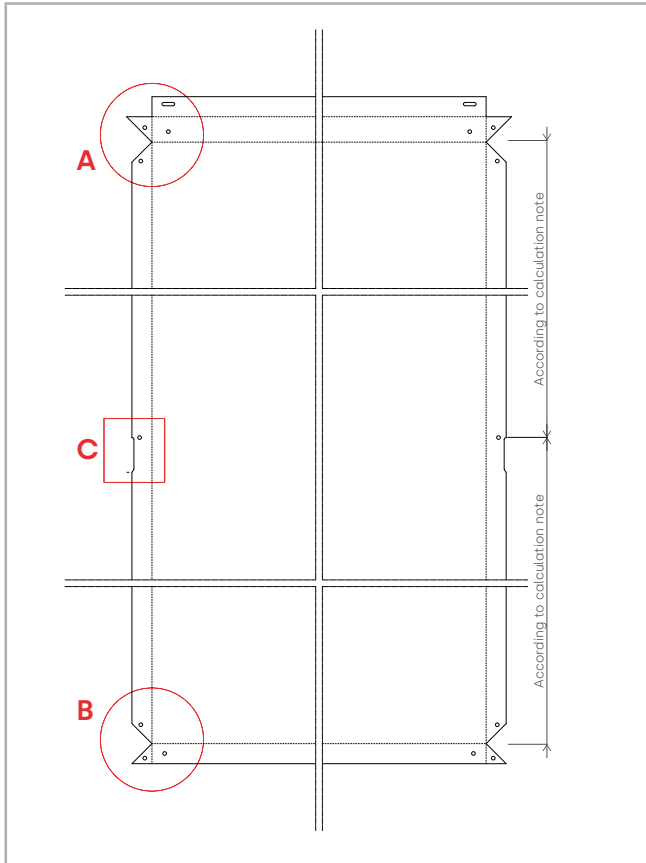

DETAIL A

DETAIL B

DETAIL C

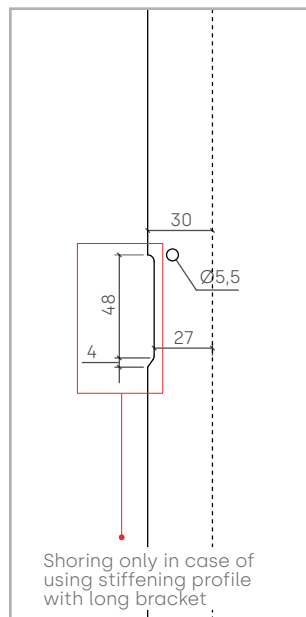
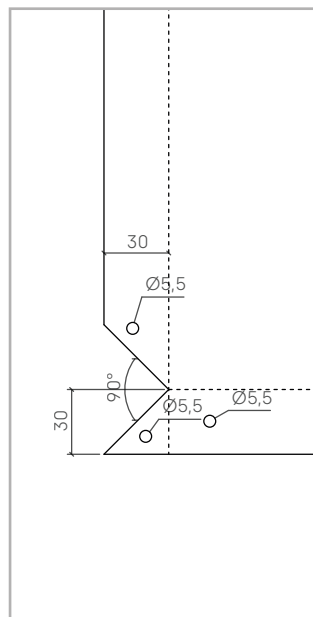
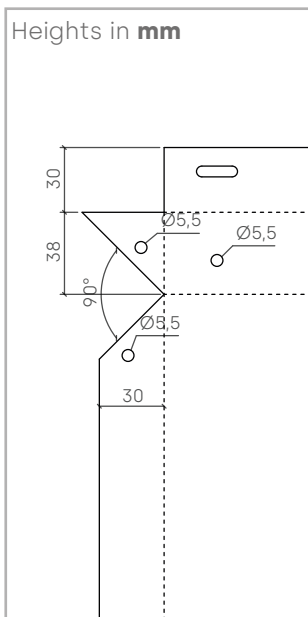

STB-T-SZ-PRO[®] SYSTEM

STANDARD WIDE BRIM SZ CASSETTE

STB-T-SZ-PRO[®] tray panels can also be produced with larger flaps 48 mm wide. They're still easier to machine than CH system tray panels. Forming becomes a simpler task too since it is carried out using screws directly fixed to S and Z mounting brackets.

The **S-shaped** bracket is placed at the bottom whilst the **Z-shaped** bracket at the top of each tray panel.

These custom mounting brackets save significant amounts of profile compared to conventional SZ systems.

UNFOLDED CASSETTE

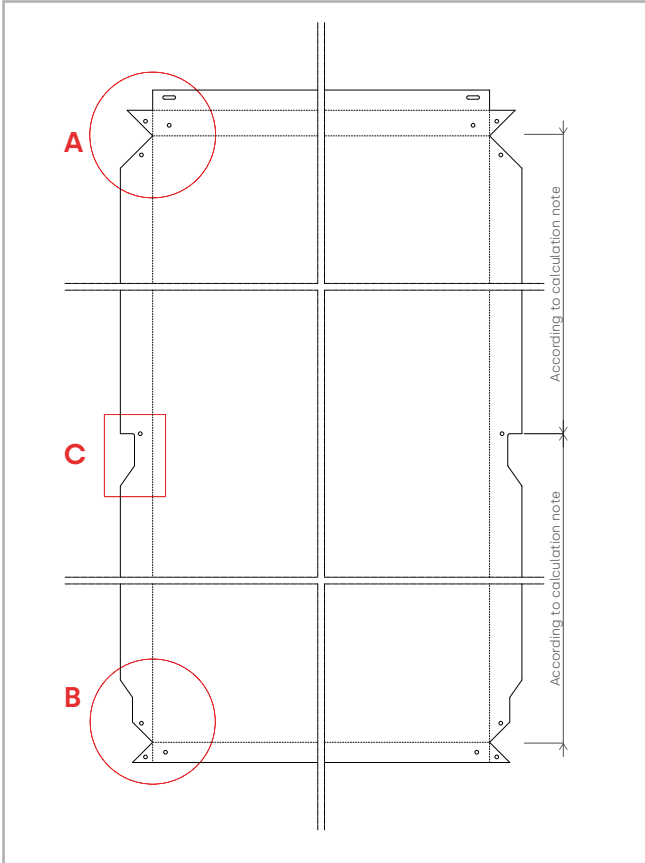

FORMED CASSETTE



The cassette **STB-T-SZ-PRO[®]** long-flange trough improves water channelling in vertical joints.

DETAIL A

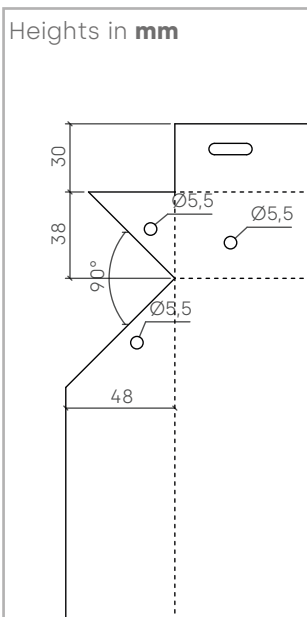

DETAIL B

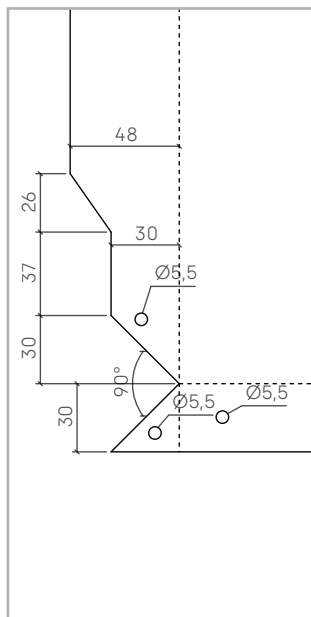

DETAIL C

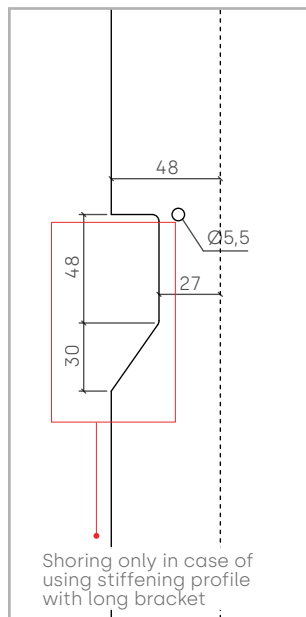

SEE CASSETTE FORMING VIDEO



STB-T-SZ-PRO® SYSTEM

NEW COMPONENTS OF THE SYSTEM

NEW HORIZONTAL STIFFENER

The horizontal stiffener is an optional extruded aluminium profile, which allows the construction **of large-sized SZ cassettes in both horizontal and vertical modulations, and allowing the free disassembly of the cassette and its subsequent reuse** (unlike the cassettes in which the STB-T-SZ reinforcement is used).

The T-profile must be clipped into the horizontal SZ stiffening brackets, which are pre-fixed to all mullion profiles.

The use of these stiffeners not only **improves the versatility of STB-T-SZ-PRO®**, but it also allows to **increase the maximum spacing between uprights** compared to a system without stiffeners or with STB-T-SZ reinforcements.

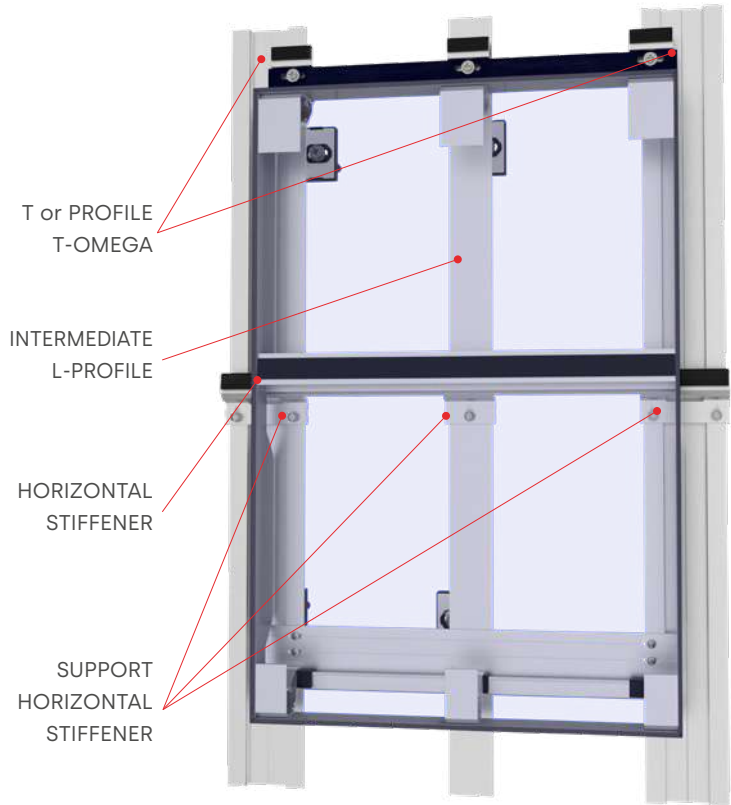

The number of stiffeners to be placed will be indicated in the wind calculation note issued by the **STACBOND** technical office.

HORIZONTAL STIFFENER PLACEMENT



Clean the gluing area of the stiffener and cassette with a specific cleaner.

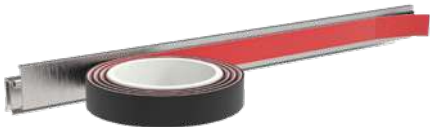

3M VHB Structural Tape 3M VHB GPH-160GF series* 1.6 mm thick and 25 mm wide.



*Bonding can also be carried out with elastic adhesive specific for this application.

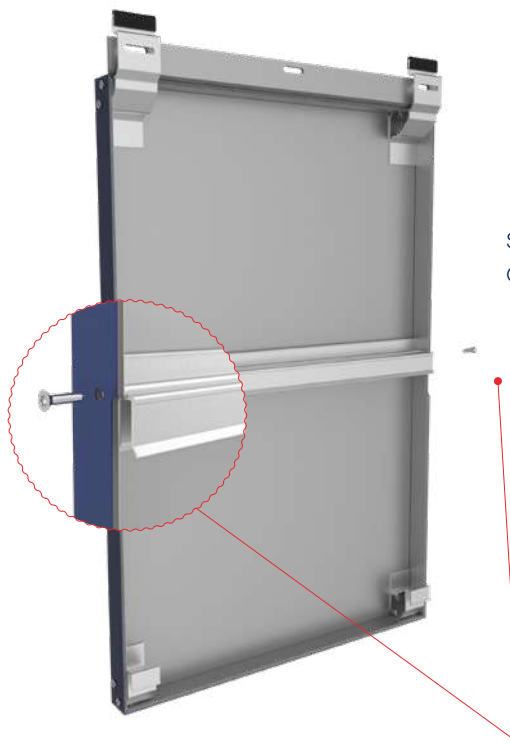

System compatible with Omega substructure.

Fasten at the ends with screws.



EVOLUTION OF THE STB-T-SZ SYSTEM to STB-T-SZ-PRO®

ADDITIONAL COMPONENTS

NEW "Z" AND "S" BRACKETS

With these new accessories, we have converted a continuous concealed fastening system into a **point fastening system**, consisting solely of **screws** (without any rivets).

The horizontal joints (now 8 mm) have a **double upper flange** that gives them visual homogeneity. In addition, the vertical joints are completely uncluttered and visually free of any fasteners.

As a result, the **STB-T-SZ-PRO® system** is:

- The most aesthetic of the concealed fixing systems.
- Lower cost of materials.
- Quicker to form.
- Easier and faster to install.
- More competitive, more PRO®.

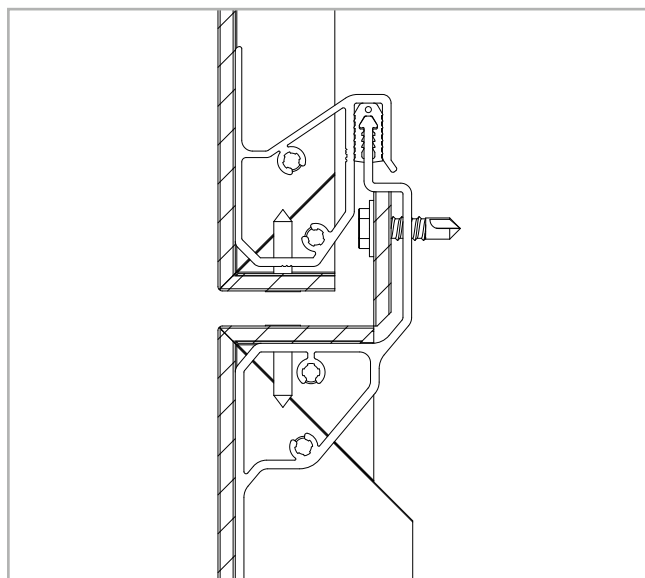

Position of the Z- and S-brackets on the shaped cassette.

EVOLUTION OF THE **STB-T-SZ SYSTEM** to **STB-T-SZ-PRO®**

NEW COMPONENTS OF THE SYSTEM

NEW STARTER PROFILE AND CLOG REMOVERS

The co-extruded **gap seal** is simply fitted to the starter profile at the **Z-brackets**.

This gasket is supplied pre-installed on the Z-brackets of the **STB-T-SZ-PRO®** system.

This avoids possible vibrations between cassettes, and allows the adjustment of cassettes to ensure the correct levelling of the pieces.

We also have a **new starter profile**, to be able to place the first cassette at the foot of the façade, with this being completely hidden.

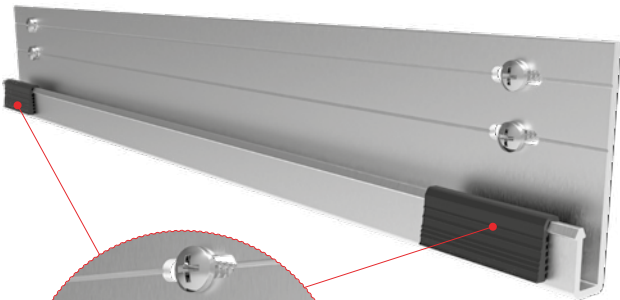
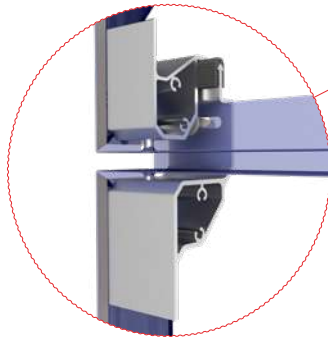

EVOLUTION OF THE **STB-T-SZ SYSTEM** to **STB-T-SZ-PRO®**

NEW COMPONENTS OF THE SYSTEM

CUTTERBLOCK JOINTS

The long brackets make it possible to easily make cutterblock joints.

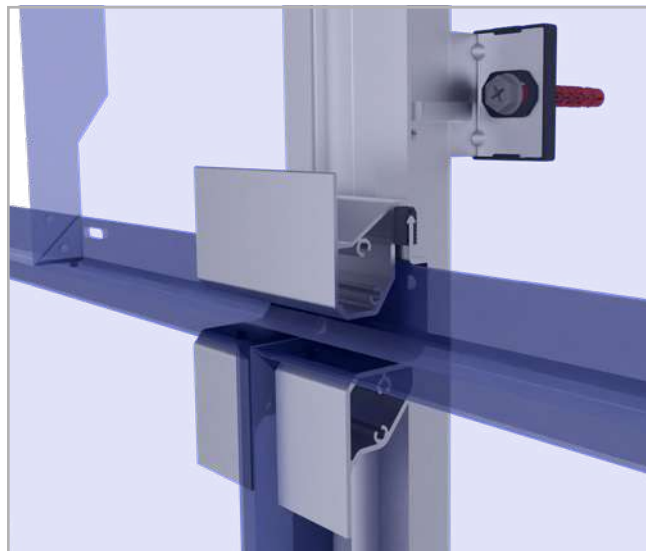
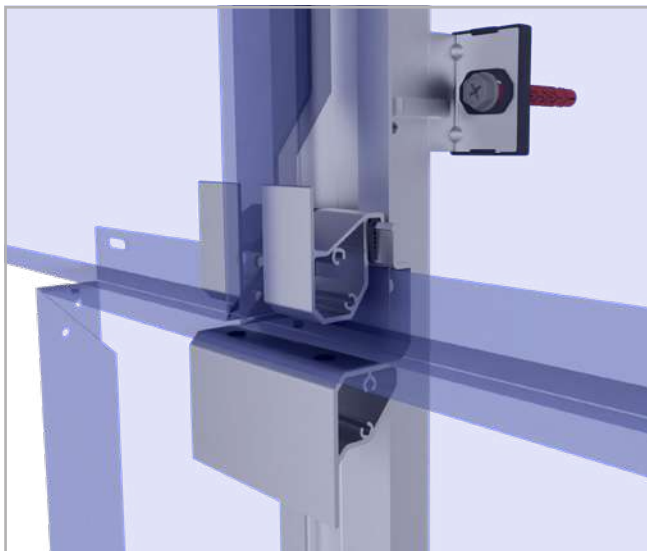

POSSIBILITY OF CONTINUOUS TRIM

The horizontal stiffener makes it possible to execute continuous trim and reframing, which could not be achieved with the STB-SZ system (individual reframing).

The horizontal stiffener allows the execution of continuous trims and reframing, which could not be achieved with the STB-T-SZ system.



Enclosures with the former STB-T-SZ system.



Continuous enclosures with the **PRO®** system.

EVOLUTION OF THE STB-T-SZ SYSTEM to **STB-T-SZ-PRO®**

NEW FORMS OF MODULATION

HORIZONTAL AND VERTICAL MODULATIONS

The **PRO®** system allows for lighter façades, with fewer materials and less assembly time.

In addition to the versatility in modulation, it **allows a maximum spacing between vertical uprights of 1200 mm***, much wider than traditional SZ.



* Measurement to be consulted according to specific STACBOND calculation note.



SAVINGS IN MATERIALS

Achieve greater spacing between uprights and save on the amount of substructure to be used.

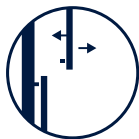

DETACHABLE AND REUSABLE

The cassettes can be easily replaced thanks to the horizontal stiffener.

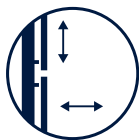

FACADES WITHOUT LIMITS

Designed for the execution of façades with horizontal and vertical modulation.



MORE AESTHETIC

It allows the execution of continuous recesses and horizontal joints with the same finish as the panel.

INSULATING WEDGES

REF.	COMPONENT
05.19.066	INSULATING WEDGE FOR SPACERS DOUBLE L WITH REF: 05.19.042 / 05.19.045
05.19.068	INSULATING WEDGE FOR SPACERS L WITH REF: 05.19.053 / 05.19.054 / 05.19.055 / 05.19.056 / 05.19.082 / 05.19.083 / 05.19.084 / 05.19.085
05.19.072	INSULATING WEDGE FOR SPACERS L WITH REF: 05.19.041 / 05.19.044 / 05.19.051 / 05.19.052 / 05.19.078 / 05.19.079 / 05.19.080 / 05.19.081
05.19.070	3 x GROOVE WASHERS FOR SPACERS L WITH REF: 05.19.066 / 05.19.068 / 05.19.072

SPACERS

REF.	COMPONENT
05.19.041	SPACER L 68
05.19.044	SPACER L 92
05.19.051	SPACER L 116
05.19.052	SPACER L 140
05.19.053	SPACER L 164
05.19.054	SPACER L 188
05.19.055	SPACER L 212
05.19.056	SPACER L 236
05.19.078	SPACER INOX L 61
05.19.079	SPACER INOX L 85
05.19.080	SPACER INOX L 109
05.19.081	SPACER INOX L 133
05.19.082	SPACER INOX L 157
05.19.083	SPACER INOX L 181
05.19.084	SPACER INOX L 205
05.19.085	SPACER INOX L 229
05.19.042	SPACER DOUBLE L 68
05.19.045	SPACER DOUBLE L 92

PROFILES

REF.	COMPONENT
05.19.043	PROFILE T
05.19.059	PROFILE L INTERMEDIATE
05.19.061	PROFILE T-OMEGA
05.19.094	SHORT Z-BRACKET
05.19.095	LONG Z-BRACKET
05.19.096	SHORT S-BRACKET
05.19.097	LONG S-BRACKET
05.19.099	STARTER PROFILE

ADDITIONAL COMPONENTS

REF.	COMPONENT
05.19.101	SZ HORIZONTAL STIFFENER LONG BRACKET
05.19.100	SZ HORIZONTAL STIFFENER SHORT BRACKET
05.19.110	SZ HORIZONTAL STIFFENER MINI BRACKET
05.19.123	PIECE OF GASKET JOINT
05.19.107	STIFFENING PROFILE

FIXING ACCESSORIES

REF.	COMPONENT
STB-T0800	ANCHOR + SCREW SET FOR FIXING BRACKET TO WALL X3 10X80 HEX. 3DG WIDE NECK
STB-T0801	ANCHOR + SCREW SET FOR FIXING BRACKET TO WALL SDF-KB-10X80-E A4 STAINLESS STEEL WIDE NECK
STB-T0300	SELF-TAPPING SCREW SDA5/3.5-6-H13-SA-5.5X20
STB-T0310	SLIDING POINT BRACKET-PROFILE FIXING SCREW JT9-2/5-5.0x25 VARIO STAINLESS STEEL A4
STB-T0311	DRILL BIT JT4-3H/5-5.5x19 INOX-A2 - FIXED POINT
STB-T0312	DRILL BIT JT9-3H/5-5.5x19 INOX-A4 - FIXED POINT
STB-T0600	SELF-DRILLING SCREW 4.2x19 STAINLESS STEEL A2 DIN 7504-N ROUNDED CYLINDRICAL HEAD
STB-T0610	SELF-DRILLING SCREW 4.2x19 STAINLESS STEEL A2 DIN 7504-K HEXAGONAL HEAD
STB-T0700	FLAT HEAD SCREW - 4,2x20



See all available accessories on page 131

STB-T-SZ-PRO® SYSTEM

TOTAL THICKNESS RATIO, ACCORDING TO SPACERS AND INSULATOR

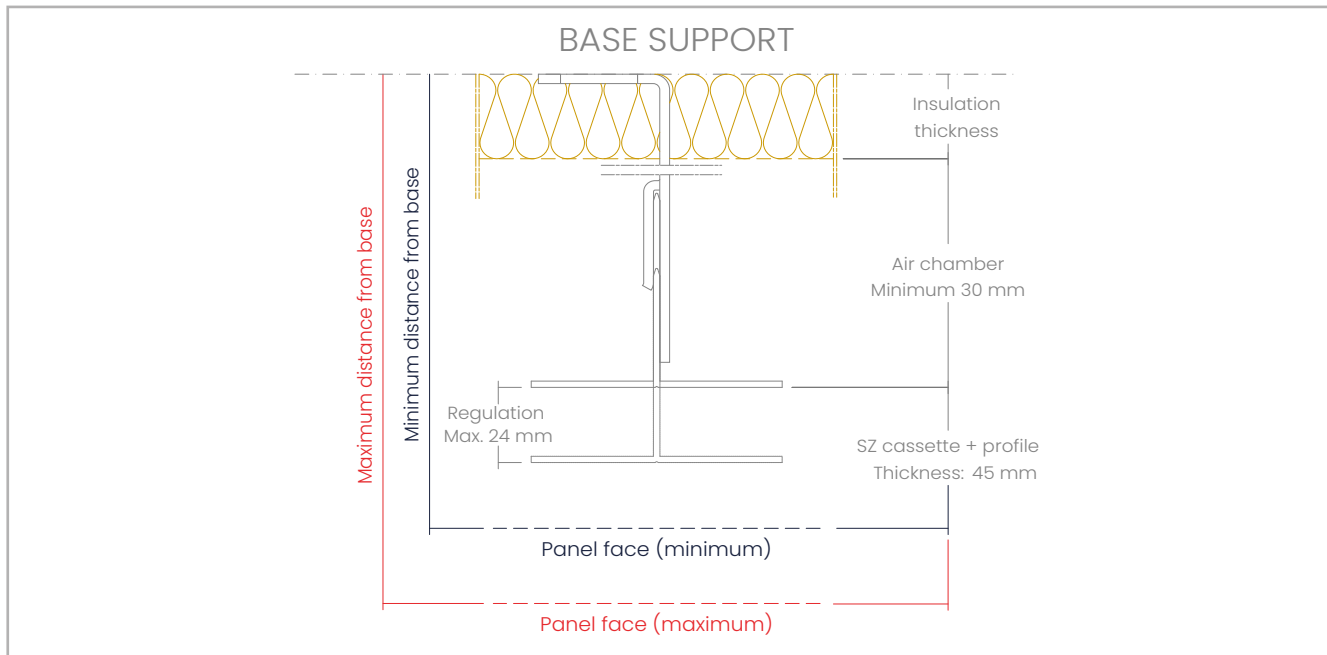

Note: the use of insulating wedges will increase the distance to the outer face of the panel by 5 mm.

SPACER L		DISTANCE (mm) FROM THE BASE OF THE ANCHORING TO EXPOSED PANEL FACE		INSULATING THICKNESS (mm) FOR 24 mm REGULATION*
REF.	COMPONENT	MINIMUM	MAXIMUM	MAXIMUM
05.19.041	SPACER L 68	121	145	—
05.19.044	SPACER L 92	145	169	40
05.19.051	SPACER L 116	169	193	60
05.19.052	SPACER L 140	193	217	80
05.19.053	SPACER L 164	217	241	110
05.19.054	SPACER L 188	241	265	130
05.19.055	SPACER L 212	265	289	160
05.19.056	SPACER L 236	289	313	180

SPACER INOX L		DISTANCE (mm) FROM THE BASE OF THE ANCHORING TO EXPOSED PANEL FACE		INSULATING THICKNESS (mm) FOR 24 mm REGULATION*
REF.	COMPONENT	MINIMUM	MAXIMUM	MAXIMUM
05.19.078	SPACER INOX L 61	116	140	—
05.19.079	SPACER INOX L 85	140	164	30
05.19.080	SPACER INOX L 109	164	188	60
05.19.081	SPACER INOX L 133	188	212	80
05.19.082	SPACER INOX L 157	212	236	100
05.19.083	SPACER INOX L 181	236	260	130
05.19.084	SPACER INOX L 205	260	284	150
05.19.085	SPACER INOX L 229	284	308	180

SPACER DOUBLE L		DISTANCE (mm) FROM THE BASE OF THE ANCHORING TO EXPOSED PANEL FACE		INSULATING THICKNESS (mm) FOR 24 mm REGULATION*
REF.	COMPONENT	MINIMUM	MAXIMUM	MAXIMUM
05.19.042	SPACER DOUBLE L 68	121	145	—
05.19.045	SPACER DOUBLE L 92	145	169	40

*For the calculation of the maximum admissible thickness, rigid insulation has been taken into account, guaranteeing the maximum regulation of each system and maintaining an air gap of ≥ 30 mm.

STB-T-REM

RIVETED SYSTEM

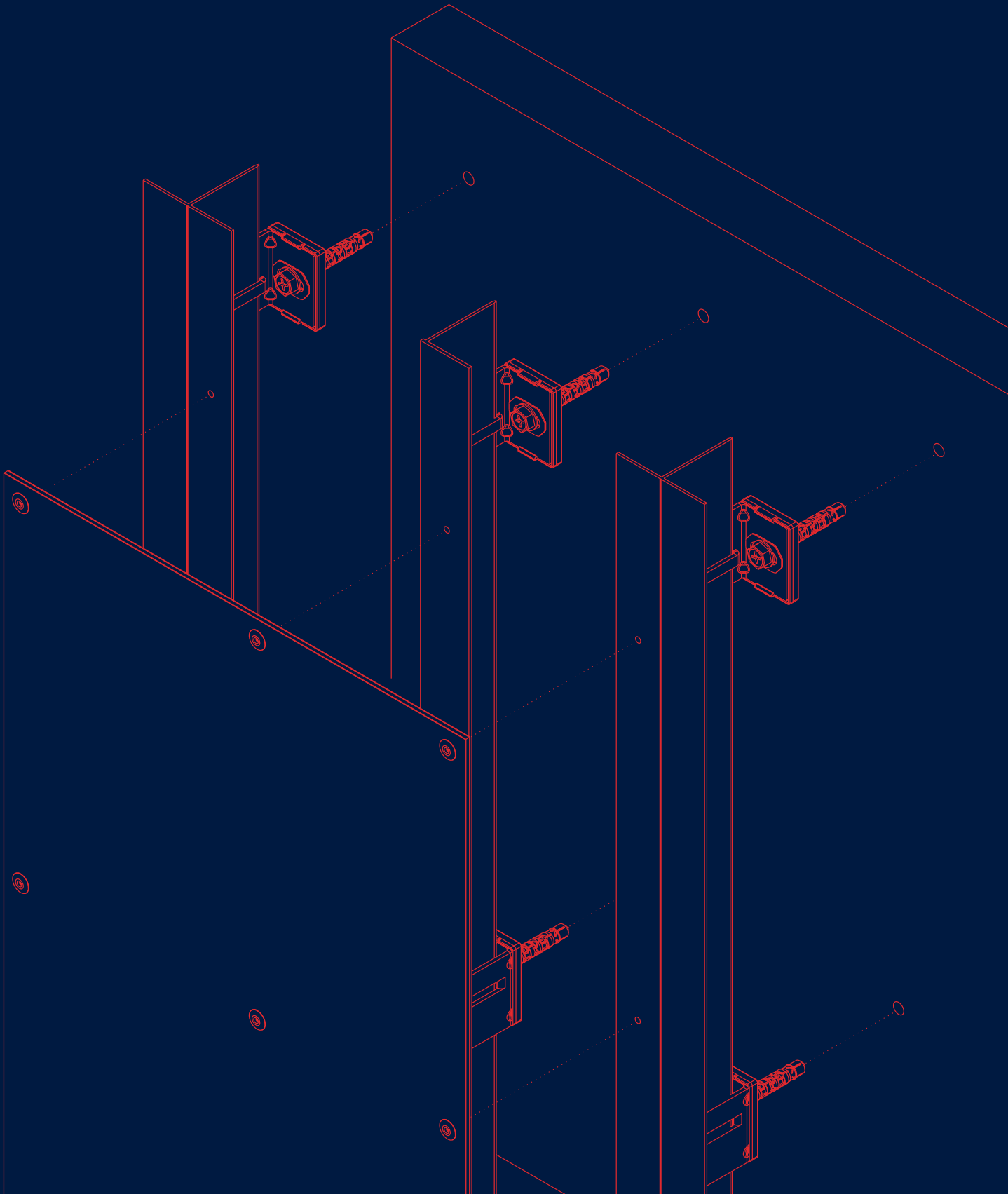

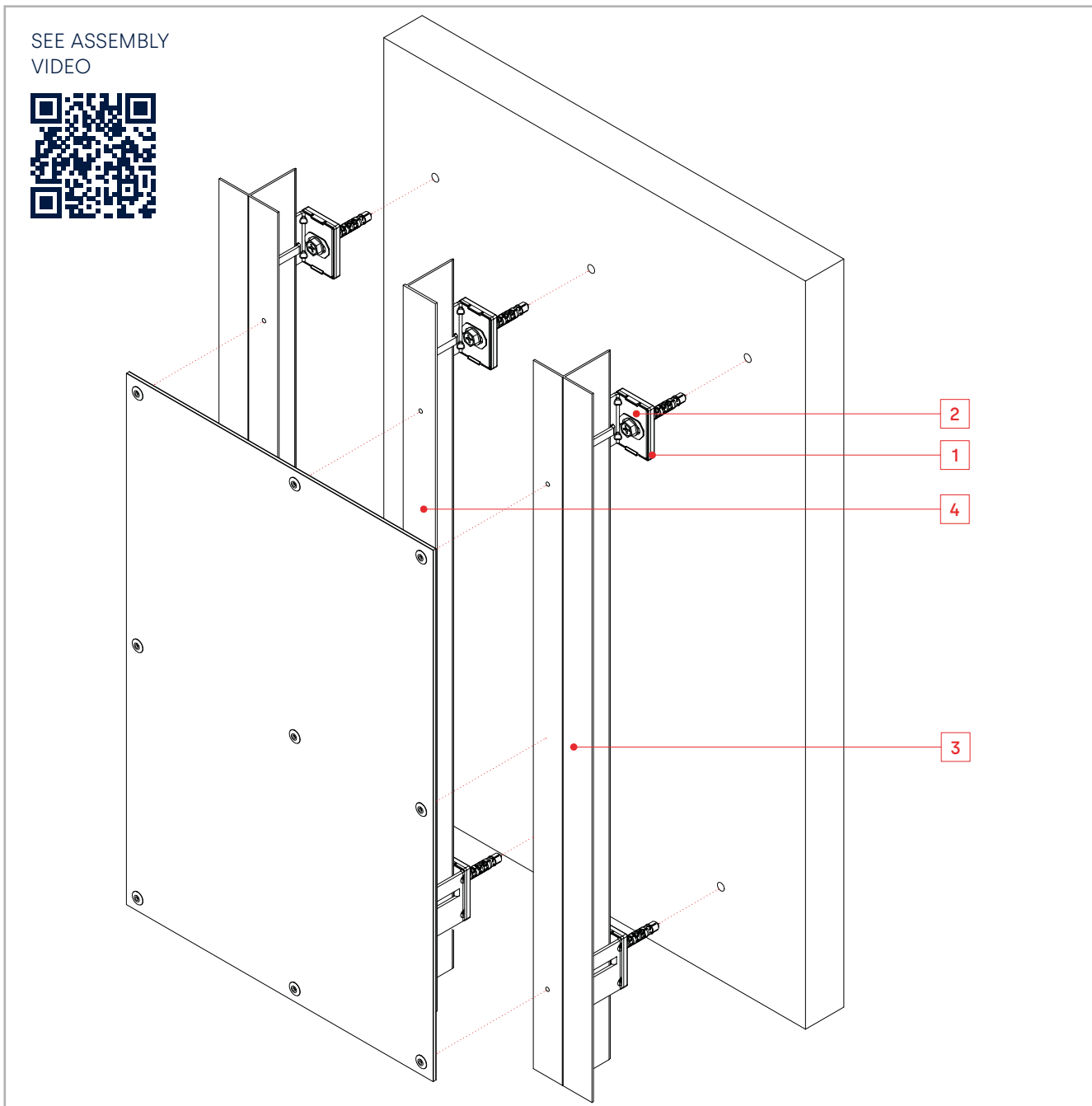

The **STB-T-REM** is a kit system of unformed panels from **STACBOND composite panels for the assembly of ventilated façades**. It is an exposed fastening system that is quick to assemble and can be used for both horizontal and vertical cut-outs. It is a very versatile system that is adaptable and offers the possibility to execute curved areas in a simple way. Therefore, the **STB-T-REM** system meets all the requirements for the most demanding architectural coatings.

The substructure is composed of **L-spacers** (alloy 5005 H24 or INOX AISI 304/430), and **T or L** shaped profiles (alloy 6063 T5/T6).

The spacers are provided in various lengths to accommodate the necessary thickness of thermal insulation and absorb all the irregularities of the façade. In order to avoid thermal bridges STAC has developed specific **INSULATING SOCKS** to be placed between L-spacers and wall facing.

STACBOND tray panels are fixed to the substructure (T/L) using large flange head alu/stainless steel rivets (ref. STB-R0100).

The **STB-T-REM** system complies with the main international certifications.

INSULATING WEDGE AND GROOVE WASHER (1)

REF. 05.19.068 / 05.19.072

REF. 05.19.070

Optional insulating wedges and insulation covers, for eliminating thermal bridges in spacers.



SPACER DOUBLE L

REF. 05.19.042 / 05.19.045

Designed to jointly connect two studs to the supporting wall.

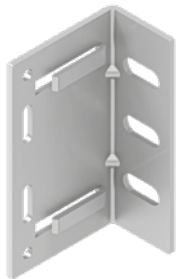

PROFILE L INTERMEDIATE (4)

REF. 05.19.059

In the intermediate position of the cassettes, for fixing **STACBOND composite panel**.



SPACER L (2)

REF. 05.19.041 / 05.19.044 / 05.19.051 / 05.19.052 / 05.19.053 / 05.19.054 / 05.19.055 / 05.19.056

Designed to connect the studs to the supporting wall. Available in different sizes depending on the desired system thickness.

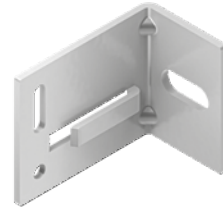

PROFILE T (3)

REF. 05.19.043

In vertical joints between cassettes, for fixing **STACBOND composite panels**.



ANCHOR AND SCREW

REF. STB-T0800 / STB-T0801

For fixing the spacer to concrete or masonry. The specific load shall be checked by extraction test according to ETAG 020.



STB-T-REM SYSTEM

SYSTEM COMPONENTS

SEPARATOR / UPRIGHT FIXING SCREW

REF. STB-T0300 / STB-T0310 / STB-T0311 / STB-T0312

For fixing the upright to the spacer.



BLIND RIVET

REF. STB-R0100

For fixing panels on structures STB-T-REM.

(* Possibility of delivery lacquered



STAINLESS STEEL BLIND RIVET

REF. STB-R0200

For fixing panels on STB-T-REM structures for high chloride exposure environments.

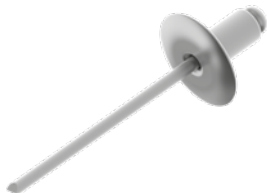

SAFETY SCREW

REF. STB-T0100

For fixing panels on structures STB-T-REM.

(* Possibility of delivery lacquered



NOZZLE FOR RIVETING MACHINE

REF. STB-FIJA-201 / STB-FIJA-202

Allows to limit the clamping force of the rivet head against the panel.

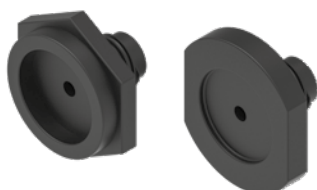

DOUBLE DRILL BIT

REF. STB-FIJA-203

Allows simultaneous drilling of the panel to 7 mm diameter and the substructure to 5.1 mm diameter.



DEPTH STOP

REF. STB-FIJA-204

Together with the double bit it allows to limit the thickness of the 7 mm hole in the panel.



CENTERING DEVICE

REF. STB-FIJA-205 / STB-FIJA-206 / STB-FIJA-207

To drill a 5.1 mm hole in the substructure centred on the sliding points of the panel.



DRIVER BIT

REF. STB-FIJA-208

For fixing the safety screw.



MANUAL CENTRING DEVICE

REF. STB-FIJA-209

For centring the safety screw in the sliding points of the panel.

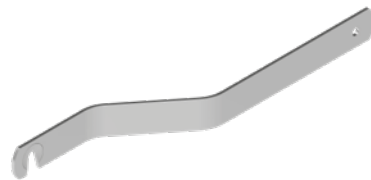

STB-T-REM SYSTEM

ADDITIONAL COMPONENTS

PROFILE L INTERMEDIATE

The profile L INTERMEDIATE is used in addition to the T-profile, thus reducing the weight of the substructure.

It is used as an upright for fixing intermediate points of **STACBOND** composite panels.



PANEL EXPANSION

The composite panel, being largely composed of aluminium, is **subject to expansion and contraction due to temperature changes**.

To place the panel in the exact desired position, the panel should initially be riveted at **1 or 2 fixed points**, with holes in the panel of **5.1 mm diameter**, the location of which should **minimise the expansion of the panel in all directions**.

To avoid possible problems due to this phenomenon, and to absorb possible expansion, the rest of the holes in the panel should be **sliding points**: i.e. if the rivet body diameter is 5 mm, the **hole in the panel should be 7 to 8.5 mm in diameter**.

It is also important that the 5.1 mm drill hole in the substructure and thus the positioning of the rivets is **perfectly centred on the sliding points**, in order to allow for equal expansion in all directions. We use **centring devices** for this purpose.

In addition, in order not to block the expansion of the panel, it is important to **limit the clamping force of the rivet head against the panel**. This is achieved by using riveting machine **nozzles** to **maintain a 0.2 mm gap** between the rivet head and the panel.

CORRECT INSTALLATION *

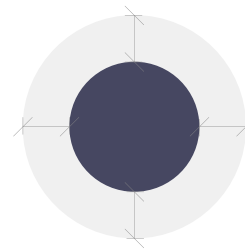

Drill hole in the substructure centred

INCORRECT INSTALLATION

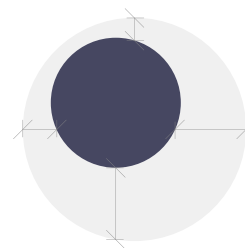

Hole in the substructure not centred

* Tools to be used **centring tool** and **nozzle for riveting tool**. See pages 80 and 81.

STB-T-REM SYSTEM

ADDITIONAL COMPONENTS

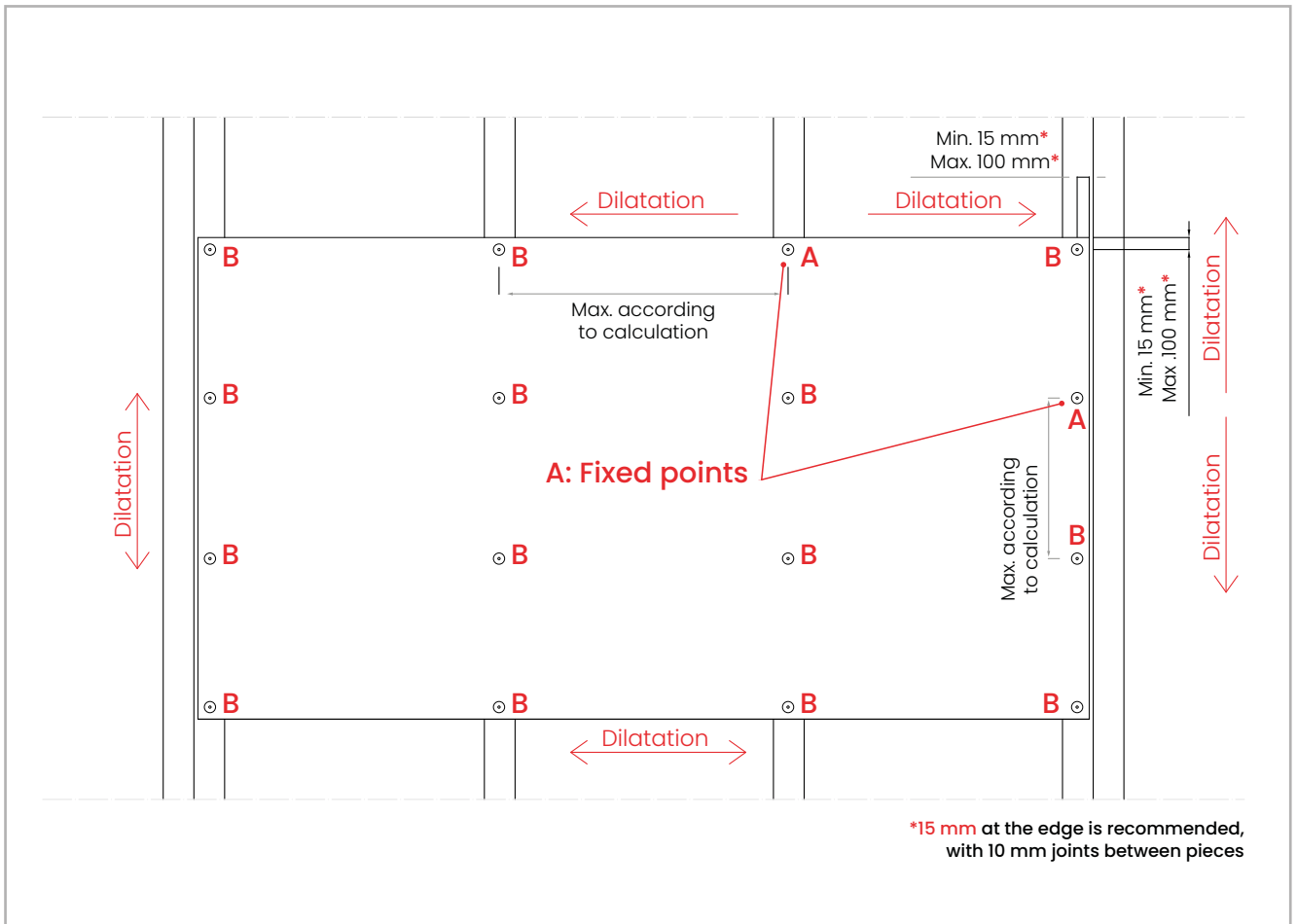

Note: other rivets or similar fasteners may be used provided that their mechanical characteristics are equal to or superior to those specified by **STACBOND**.

FIXED POINTS A

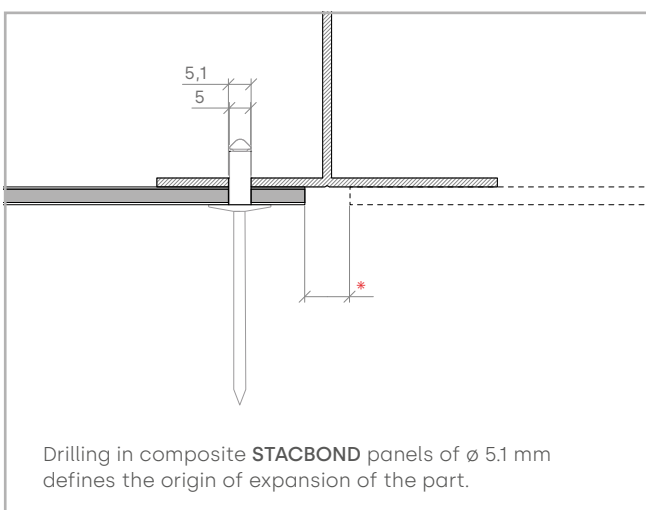

SLIDING POINTS B

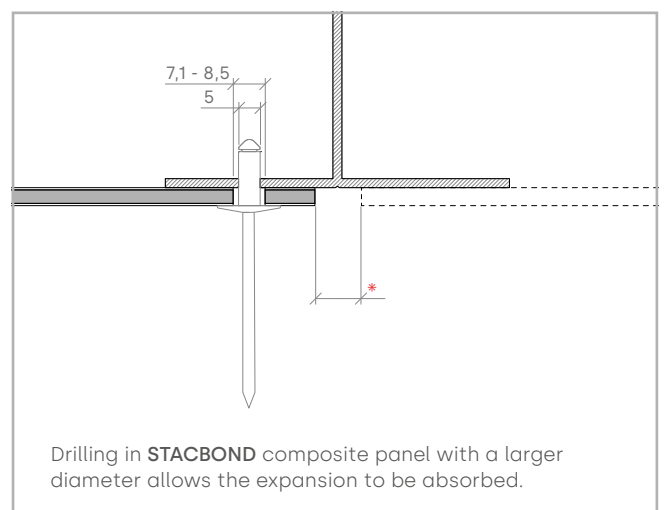

Rates in **mm**

* The size of the expansion joint between panels must be calculated according to the coefficient of thermal expansion according to the technical data sheet, and the dimensions of the pieces.

STB-T-REM SYSTEM

REFERENCE LIST

INSULATING WEDGES

REF.	COMPONENT
05.19.066	INSULATING WEDGE FOR SPACERS DOUBLE L WITH REF: 05.19.042 / 05.19.045
05.19.068	INSULATING WEDGE FOR SPACERS L WITH REF: 05.19.053 / 05.19.054 / 05.19.055 / 05.19.056 / 05.19.082 / 05.19.083 / 05.19.084 / 05.19.085
05.19.072	INSULATING WEDGE FOR SPACERS L WITH REF: 05.19.041 / 05.19.044 / 05.19.051 / 05.19.052 / 05.19.078 / 05.19.079 / 05.19.080 / 05.19.081
05.19.070	3 x GROOVE WASHERS FOR SPACERS L WITH REF: 05.19.066 / 05.19.068 / 05.19.072

SPACERS

REF.	COMPONENT
05.19.041	SPACER L 68
05.19.044	SPACER L 92
05.19.051	SPACER L 116
05.19.052	SPACER L 140
05.19.053	SPACER L 164
05.19.054	SPACER L 188
05.19.055	SPACER L 212
05.19.056	SPACER L 236
05.19.042	SPACER DOUBLE L 68
05.19.045	SPACER DOUBLE L 92
05.19.078	SPACER INOX L 61
05.19.079	SPACER INOX L 85
05.19.080	SPACER INOX L 109
05.19.081	SPACER INOX L 133
05.19.082	SPACER INOX L 157
05.19.083	SPACER INOX L 181
05.19.084	SPACER INOX L 205
05.19.085	SPACER INOX L 229

PROFILES

REF.	COMPONENT
05.19.043	PROFILE T
05.19.059	PROFILE L INTERMEDIATE

FIXING ACCESSORIES

REF.	COMPONENT
STB-FIJA-201	RIVETER NOSEPIECE FOR SS0-D15 RIVETS INOX/INOX
STB-FIJA-202	RIVETER NOSEPIECE FOR RIVETS ALU/INOX AP14
STB-FIJA-203	DUAL DIAMETER DRILL BIT (HSS-7.0/5.1x74)
STB-FIJA-204	DEPTH LIMITER 16x18
STB-FIJA-205	CENTRING GAUCHE (DG-146x20-7)
STB-FIJA-206	REPLACEMENT NOSEPIECE DEVICE FOR CENTRING GAUGE Ø 7 mm
STB-FIJA-207	SPECIAL DRILL BIT FOR CENTRING GAUCHE (HSS-DG-5,1x110)
STB-FIJA-208	DRIVER BIT T20WW-25-HEX1/4"
STB-FIJA-209	MANUAL CENTRING GAUCHE FOR SLA3 SCREW
STB-FIJA-210	SOCKET IRIUS G-00106.07
STB-T0100	SECURITY SCREW 4.8x19 INOX HEAD TORX SLA3/6-S-D12-4.8x19
STB-T0300	SELF-TAPPING SCREW SDA5/3.5-6-H13-SA-5.5X20
STB-T0310	SLIDING POINT BRACKET-PROFILE FIXING SCREW JT9-2/5-5.0x25 VARIO STAINLESS STEEL A4
STB-T0311	DRILL BIT JT4-3H/5-5.5x19 INOX-A2 - FIXED POINT
STB-T0312	DRILL BIT JT9-3H/5-5.5x19 INOX-A4 - FIXED POINT
STB-T0800	ANCHOR + SCREW SET FOR FIXING BRACKET TO WALL X3 10X80 HEX. 3DG WIDE NECK
STB-T0801	ANCHOR + SCREW SET FOR FIXING BRACKET TO WALL SDF-KB-10X80-E A4 STAINLESS STEEL WIDE NECK
STB-R0100	ALU/SS RIVET Ø5X12, D.HEAD 14
STB-R0200	FACADE RIVET HEAD 15 mm INOX/INOX A4 5x14 SS0-D15-50140



See all available accessories on page 131

STB-T-REM SYSTEM

TOTAL THICKNESS RATIO, ACCORDING TO SPACERS AND INSULATOR

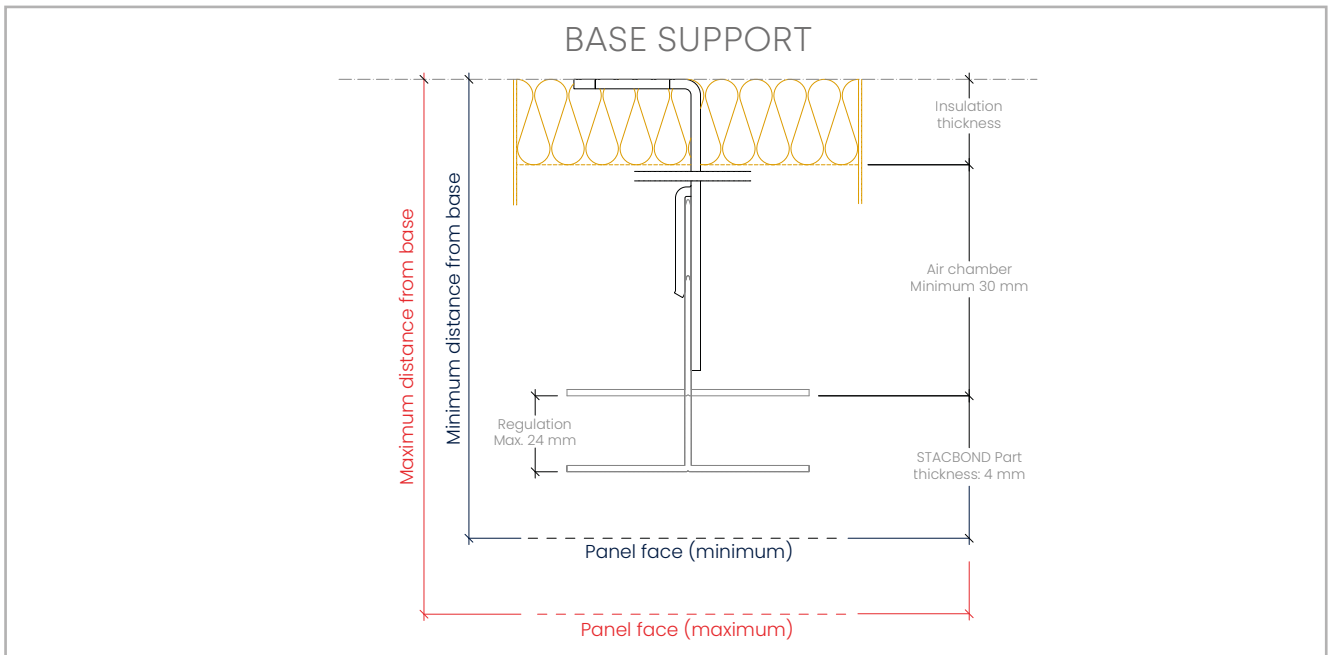

Note: the use of insulating wedges will increase the distance to the outer face of the panel by 5 mm.

SPACER L		DISTANCE (mm) FROM THE BASE OF THE ANCHORING TO EXPOSED PANEL FACE		INSULATING THICKNESS (mm) FOR 24 mm ADJUSTMENT*
REF.	COMPONENT	MINIMUM	MAXIMUM	MAXIMUM
05.19.041	SPACER L 68	80	104	—
05.19.044	SPACER L 92	104	128	40
05.19.051	SPACER L 116	128	152	60
05.19.052	SPACER L 140	152	176	80
05.19.053	SPACER L 164	176	200	110
05.19.054	SPACER L 188	200	224	130
05.19.055	SPACER L 212	224	248	160
05.19.056	SPACER L 236	248	272	180

SPACER INOX L		DISTANCE (mm) FROM THE BASE OF THE ANCHORING TO EXPOSED PANEL FACE		INSULATING THICKNESS (mm) FOR 24 mm ADJUSTMENT*
REF.	COMPONENT	MINIMUM	MAXIMUM	MAXIMUM
05.19.078	SPACER INOX L 61	75	99	—
05.19.079	SPACER INOX L 85	99	123	40
05.19.080	SPACER INOX L 109	123	147	60
05.19.081	SPACER INOX L 133	147	171	80
05.19.082	SPACER INOX L 157	171	195	110
05.19.083	SPACER INOX L 181	195	219	130
05.19.084	SPACER INOX L 205	219	243	160
05.19.085	SPACER INOX L 229	243	267	180

SPACER DOUBLE L		DISTANCE (mm) FROM THE BASE OF THE ANCHORING TO EXPOSED PANEL FACE		INSULATING THICKNESS (mm) FOR 24 mm ADJUSTMENT*
REF.	COMPONENT	MINIMUM	MAXIMUM	MAXIMUM
05.19.042	SPACER DOUBLE L 68	80	104	—
05.19.045	SPACER DOUBLE L 92	104	128	40

* For the calculation of the maximum admissible thickness, rigid insulation has been taken into account, guaranteeing the maximum regulation of each system and maintaining an air gap of ≥ 30 mm.

STACBOND
more than you see

STB-T-PEG

GLUED SYSTEM

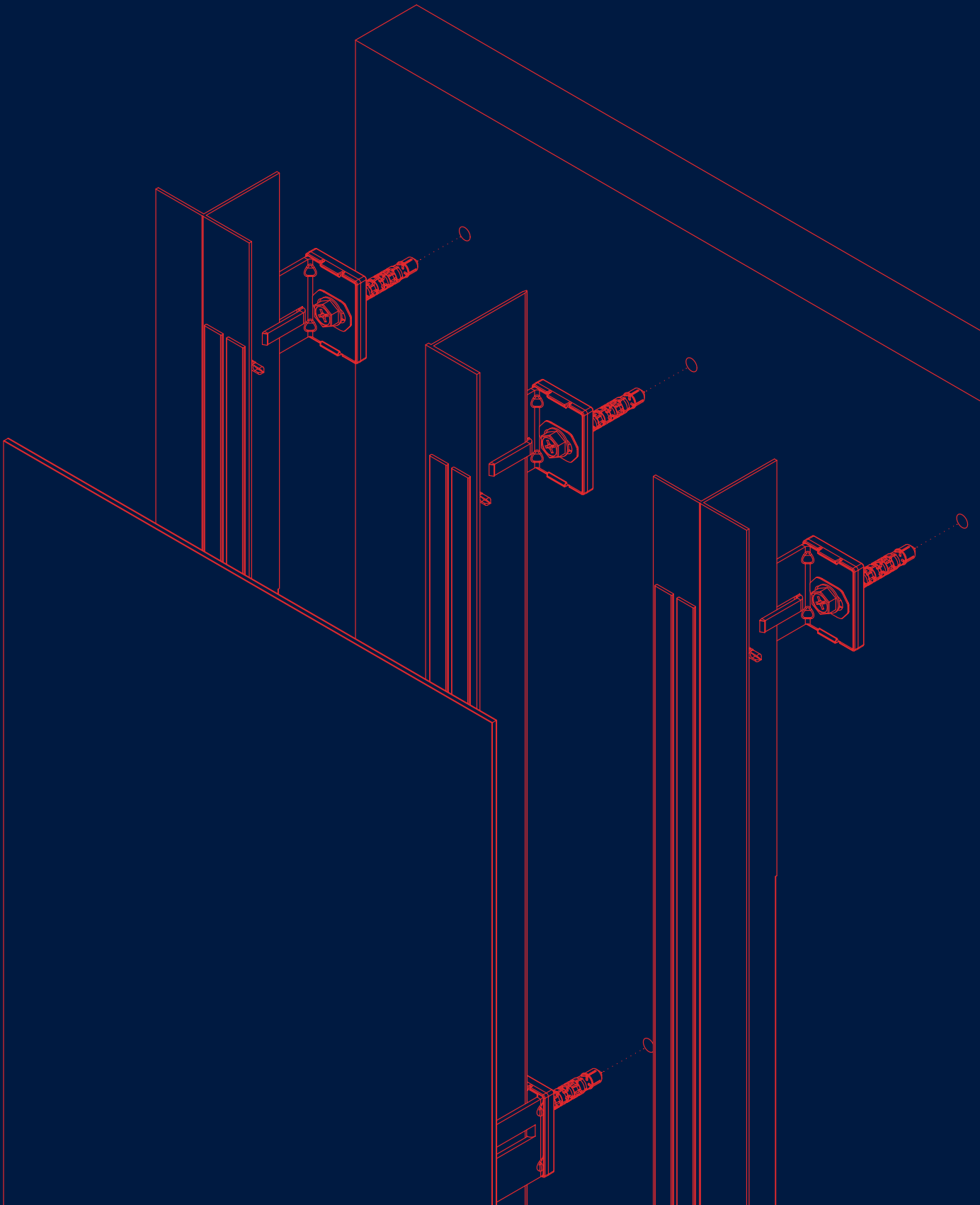

STB-T-PEG SYSTEM

DESCRIPTION

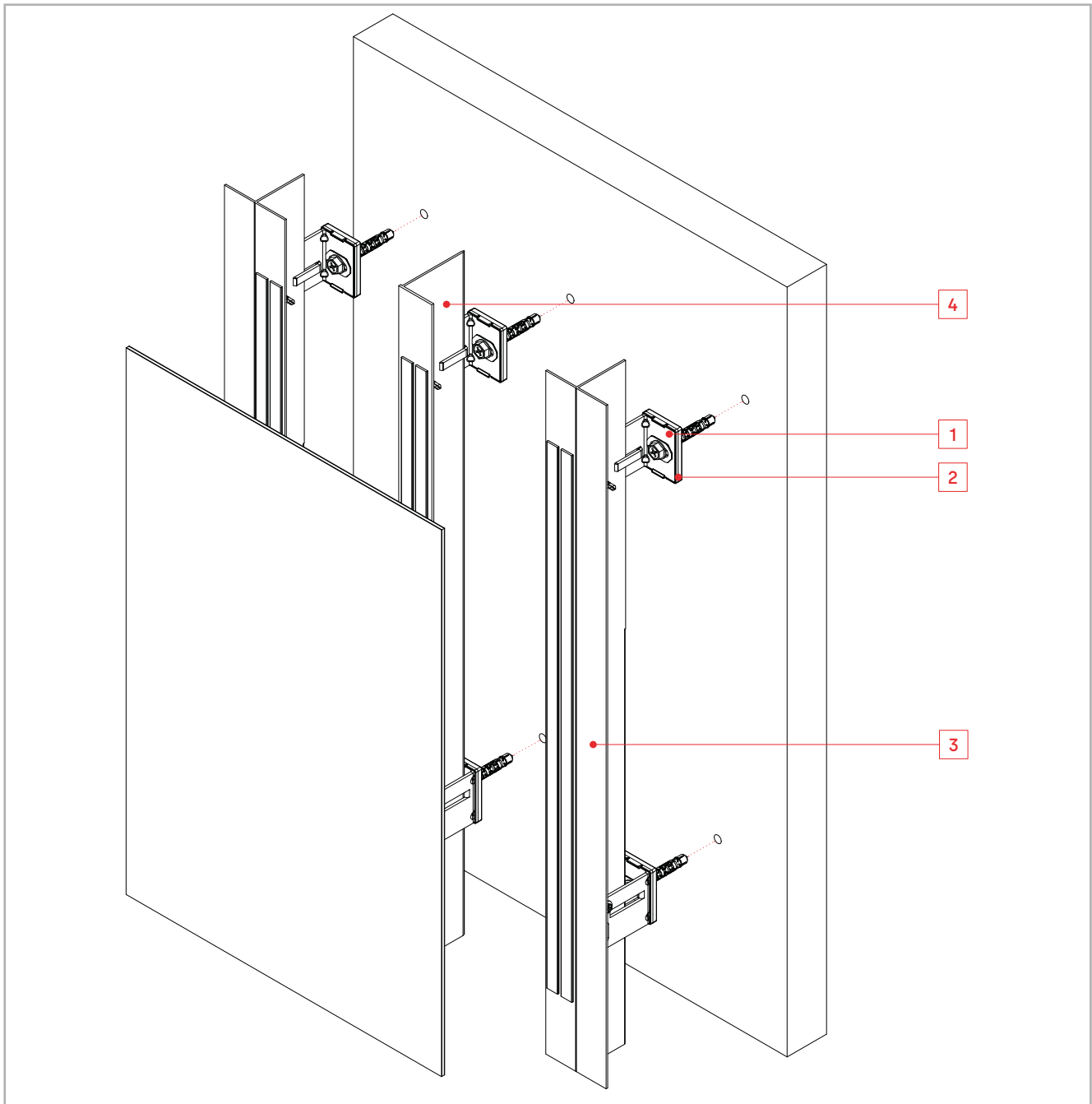

The **STB-T-PEG** is a kit system of unformed panels from **STACBOND composite panels for the assembly of ventilated façades**. It is a concealed fixing system that is quick to assemble and economical, and can be used for both horizontal and vertical cut-outs.

As a chemically bonded system, it is resistant to ageing and weathering. It also absorbs vibrations and offers multiple possibilities for façade design.

The substructure is composed of **L-spacers** (alloy 5005 H24 or INOX AISI 304/430), and **T or L** profiles (alloy 6063 T5/T6).

Spacers are provided in various lengths to accommodate the necessary thickness of thermal insulation and absorb all the irregularities of the façade. In order to avoid thermal bridges STAC has developed specific **INSULATING SOCKS** to be placed between L-spacers and wall facing.

STACBOND composite panel sheets are fixed to the substructure of vertical and/or horizontal T-profiles by means of a specific adhesive and double-sided tape.

INSULATING WEDGE AND GROOVE WASHER (1)

REF. 05.19.068 / 05.19.072

REF. 05.19.070

Optional insulating wedges and insulation covers, for eliminating thermal bridges in spacers.



SPACER DOUBLE L

REF. 05.19.042 / 05.19.045

Designed to jointly connect two studs to the supporting wall.

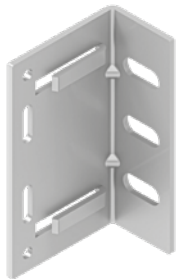

PROFILE L INTERMEDIATE (4)

REF. 05.19.059

In the intermediate position of the cassettes, for fixing **STACBOND composite panel**.



SPACER L (2)

REF. 05.19.041 / 05.19.044 / 05.19.051 / 05.19.052 / 05.19.053 / 05.19.054 / 05.19.055 / 05.19.056

Designed to connect the studs to the supporting wall. Available in different sizes depending on the desired system thickness.

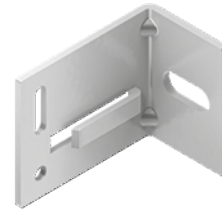

PROFILE T (3)

REF. 05.19.043

In vertical joints between cassettes, for fixing **STACBOND composite panels**.



ANCHOR AND SCREW

REF. STB-T0800 / STB-T0801

For fixing the spacer to concrete or masonry. The specific load shall be checked by extraction test according to ETAG 020.



STB-T-PEG SYSTEM

ADDITIONAL COMPONENTS

INTERMEDIATE L PROFILE

The profile L INTERMEDIATE is used in addition to the T-profile, thus reducing the weight of the substructure.

It is used as an upright for fixing intermediate points of **STACBOND composite panels**.

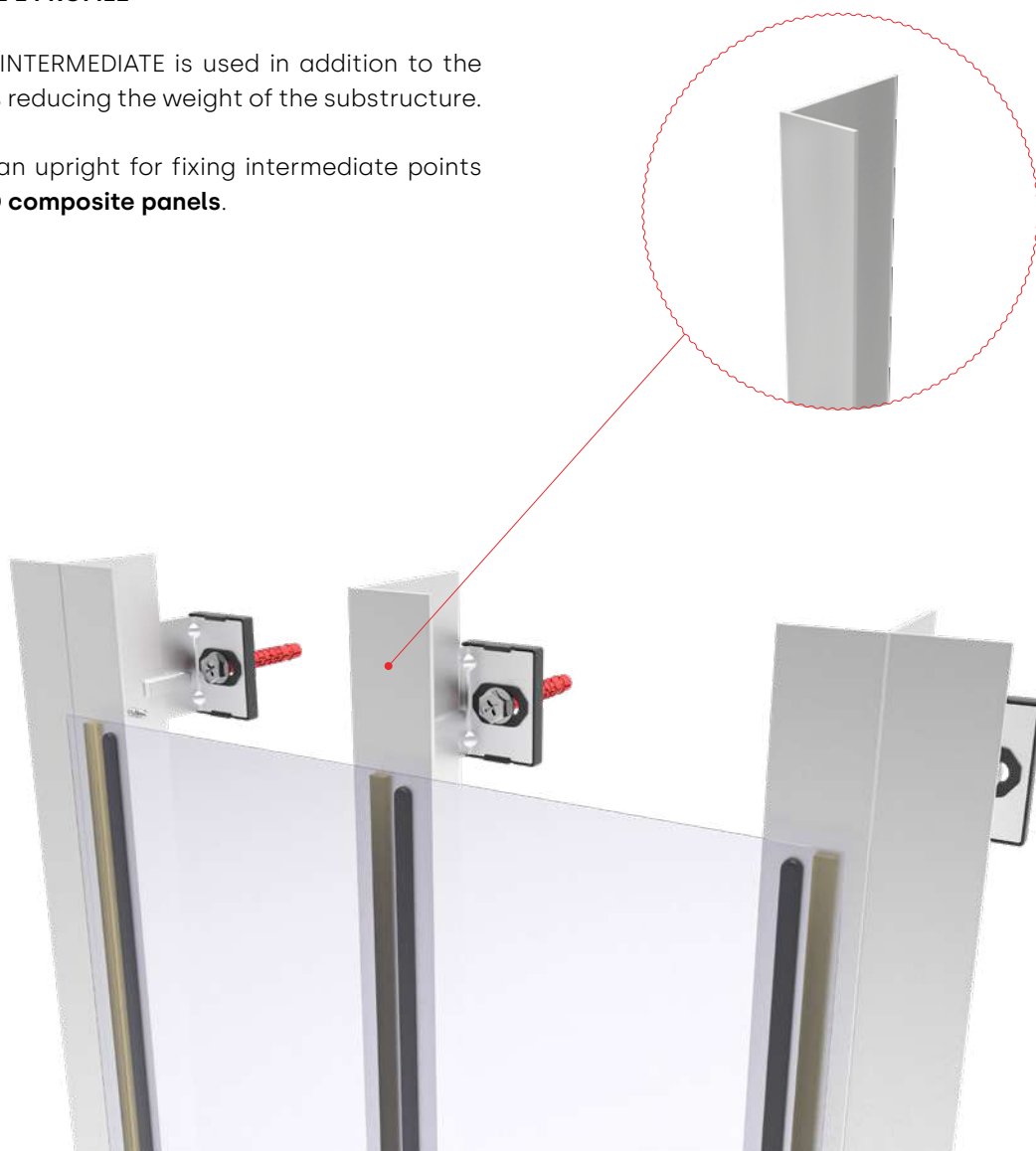

PANEL GLUING

1. Cleaning of the substructure and priming. The substructure must be clean, dry, homogeneous, free of oil, grease, dust and loose or poorly adhering particles. Paints, grouts and other coatings must be removed. The primer shall be applied with a product that reinforces the adhesion of the adhesive putty to the substructure, SIKATAACK PANEL PRIMER (or similar).

2. Application of double-sided adhesive tape. SIKATAACK PANEL -3 double-sided adhesive tape (or similar) is used for the initial fixing of the panels until the adhesive polymerises to achieve a minimum adhesive thickness of 3 mm, which absorbs possible expansion and vibrations produced in the STACBOND composite panel façade. Long-term resistance is achieved only with the adhesive.

3. Elastic adhesive. Apply a continuous vertical bead of SIKATAACK PANEL 50 (or similar) elastic adhesive using its triangular nozzle (8 mm wide, 10 mm long) at least 5 mm away from the tape. For correct application, the application gun must be positioned perpendicular to the surface.

4. Placement of the panel. Remove the protective film from the double-sided adhesive tape. Carefully position the panel in its precise place and press firmly until the panel comes into contact with the double-sided tape.



STB-T-PEG SYSTEM

REFERENCE LIST

INSULATING WEDGES

REF.	COMPONENT
05.19.066	INSULATING WEDGE FOR SPACERS DOUBLE L WITH REF: 05.19.042 / 05.19.045
05.19.068	INSULATING WEDGE FOR SPACERS L WITH REF: 05.19.053 / 05.19.054 / 05.19.055 / 05.19.056 / 05.19.082 / 05.19.083 / 05.19.084 / 05.19.085
05.19.072	INSULATING WEDGE FOR SPACERS L WITH REF: 05.19.041 / 05.19.044 / 05.19.051 / 05.19.052 / 05.19.078 / 05.19.079 / 05.19.080 / 05.19.081
05.19.070	3 x GROOVE WASHERS FOR SPACERS L WITH REF: 05.19.066 / 05.19.068 / 05.19.072

SPACERS

REF.	COMPONENT
05.19.041	SPACER L 68
05.19.044	SPACER L 92
05.19.051	SPACER L 116
05.19.052	SPACER L 140
05.19.053	SPACER L 164
05.19.054	SPACER L 188
05.19.055	SPACER L 212
05.19.056	SPACER L 236
05.19.042	SPACER DOUBLE L 68
05.19.045	SPACER DOUBLE L 92
05.19.078	SPACER INOX L 61
05.19.079	SPACER INOX L 85
05.19.080	SPACER INOX L 109
05.19.081	SPACER INOX L 133
05.19.082	SPACER INOX L 157
05.19.083	SPACER INOX L 181
05.19.084	SPACER INOX L 205
05.19.085	SPACER INOX L 229

PROFILES

REF.	COMPONENT
05.19.043	PROFILE T
05.19.059	PROFILE L INTERMEDIATE

FIXING ACCESSORIES

REF.	COMPONENT
STB-T0800	ANCHOR + SCREW SET FOR FIXING BRACKET TO WALL X3 10X80 HEX. 3DG WIDE NECK
STB-T0801	ANCHOR + SCREW SET FOR FIXING BRACKET TO WALL SDF-KB-10X80-E A4 STAINLESS STEEL WIDE NECK
STB-T0300	SELF-TAPPING SCREW SDA5/3.5-6-H13-SA- 5.5X20
STB-T0310	SLIDING POINT BRACKET-PROFILE FIXING SCREW JT9-2/5-5.0x25 VARIO STAINLESS STEEL A4
STB-T0311	DRILL BIT JT4-3H/5-5.5x19 INOX-A2 - FIXED POINT
STB-T0312	DRILL BIT JT9-3H/5-5.5x19 INOX-A4 - FIXED POINT

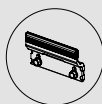

See all available accessories on
page 131

STB-T-PEG SYSTEM

TOTAL THICKNESS RATIO, ACCORDING TO SPACERS AND INSULATOR

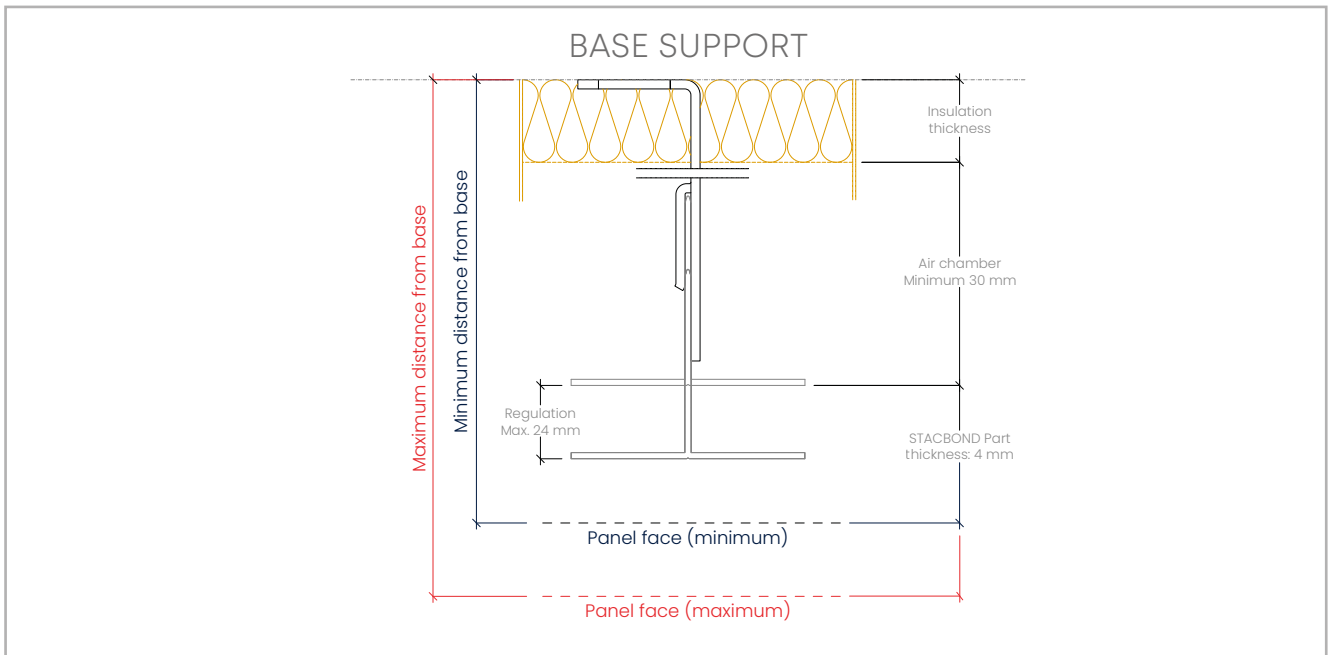

Note: the use of insulating wedges will increase the distance to the outer face of the panel by 5 mm.

SPACER L		DISTANCE (mm) FROM THE BASE OF THE ANCHORING TO EXPOSED PANEL FACE		INSULATING THICKNESS (mm) FOR 24 mm ADJUSTMENT*
REF.	COMPONENT	MINIMUM	MAXIMUM	MAXIMUM
05.19.041	SPACER L 68	80	104	—
05.19.044	SPACER L 92	104	128	40
05.19.051	SPACER L 116	128	152	60
05.19.052	SPACER L 140	152	176	80
05.19.053	SPACER L 164	176	200	110
05.19.054	SPACER L 188	200	224	130
05.19.055	SPACER L 212	224	248	160
05.19.056	SPACER L 236	248	272	180

SPACER INOX L		DISTANCE (mm) FROM THE BASE OF THE ANCHORING TO EXPOSED PANEL FACE		INSULATING THICKNESS (mm) FOR 24 mm ADJUSTMENT*
REF.	COMPONENT	MINIMUM	MAXIMUM	MAXIMUM
05.19.078	SPACER INOX L 61	75	99	—
05.19.079	SPACER INOX L 85	99	123	40
05.19.080	SPACER INOX L 109	123	147	60
05.19.081	SPACER INOX L 133	147	171	80
05.19.082	SPACER INOX L 157	171	195	110
05.19.083	SPACER INOX L 181	195	219	130
05.19.084	SPACER INOX L 205	219	243	160
05.19.085	SPACER INOX L 229	243	267	180

SPACER DOUBLE L		DISTANCE (mm) FROM THE BASE OF THE ANCHORING TO EXPOSED PANEL FACE		INSULATING THICKNESS (mm) FOR 24 mm ADJUSTMENT*
REF.	COMPONENT	MINIMUM	MAXIMUM	MAXIMUM
05.19.042	SPACER DOUBLE L 68	80	104	—
05.19.045	SPACER DOUBLE L 92	104	128	40

* For the calculation of the maximum admissible thickness, rigid insulation has been taken into account, guaranteeing the maximum regulation of each system and maintaining an air gap of ≥ 30 mm.

STACBOND
more than you see

STB-CH

HANGER SYSTEM

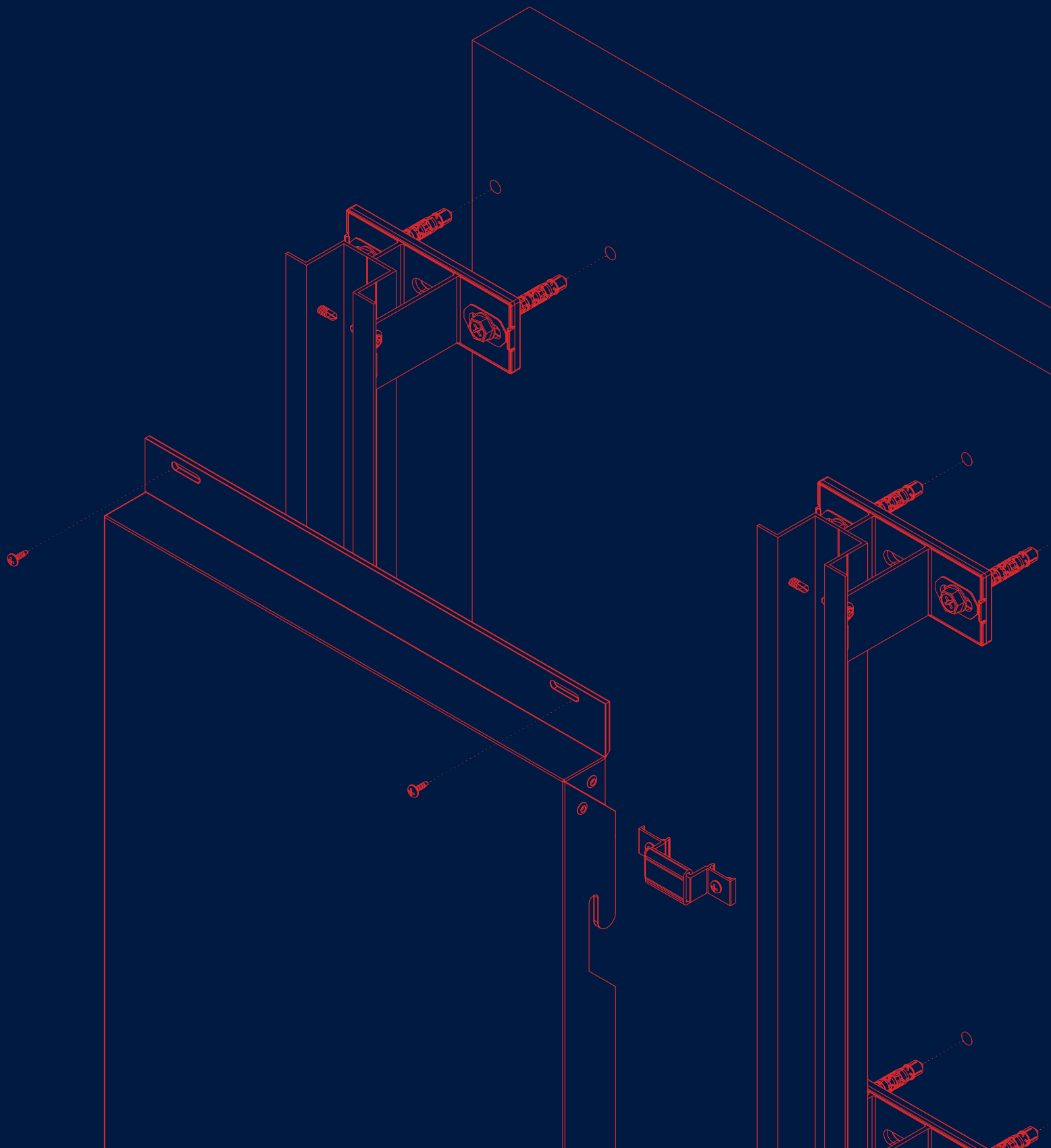

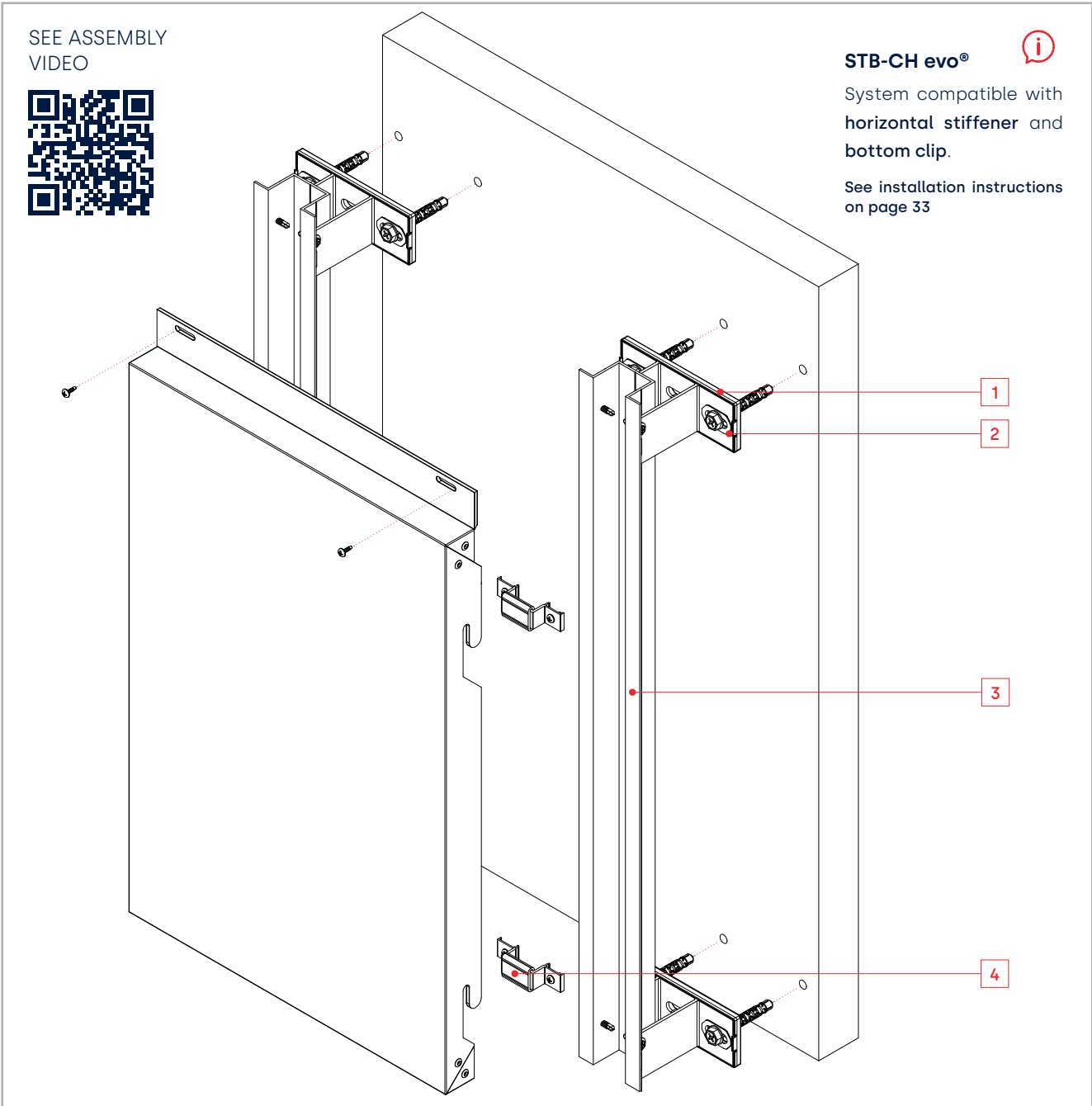

The **STB-CH** is a kit system based on hanging cassettes made of **composite STACBOND panels for the assembly of ventilated façades**. It is a versatile, fast-assembly, concealed fixing system, specially designed to develop façades with horizontal or vertical modulation.

The substructure is made of **OMEGA profiles** and **DOUBLE T spacers** made of 6063 T5/T6 aluminium alloy, on which the already formed cassettes are anchored.

These spacers have different lengths to accommodate the required thickness of thermal insulation and to absorb all the irregularities of the façade. For the

thermal bridge break **STAC** has developed specific **INSULATING WEDGES** to be placed between the **spacers DOUBLE T** and the wall facing.

The connection of the formed cassettes to the substructure is achieved by means of recesses in the vertical flanges of the cassettes and their hidden stiffeners attached on the rear face, so that they rest on the hanger supports and are screwed or riveted to the OMEGA profiles.

The **STB-CH** system complies with the main international certifications.

SHIMS AND COVER (1)

REF. 05.19.067 / 05.19.069 / 05.19.073

REF. 05.19.071

Optional insulating wedges and insulation covers, for eliminating thermal bridges in spacers.

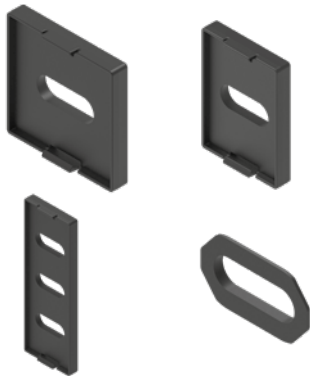

SPACER U

REF. 05.19.046 / 05.19.047

For profile and system fixing to the bracket. Available in different sizes depending on the desired system thickness.



BRACKET SET STB-CH HANGING (4)

REF. 05.19.013

To hang CH tray panels to the substructure. Fixed to the Omega profile using 2 self-drilling screws.

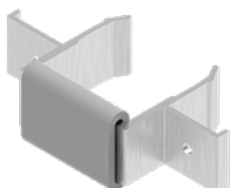

SPACER DOUBLE T (2)

REF. 05.19.004 / 05.19.005 / 05.19.006 / 05.19.007 / 05.19.030 / 05.19.031 / 05.19.032 / 05.19.033 / 05.19.034 / 05.19.035 / 05.19.036 / 05.19.037 / 05.19.038 / 05.19.039

For profile and system fixing to the bracket. Available in different sizes depending on the desired system thickness.

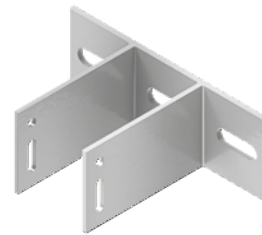

OMEGA PROFILE (3)

REF. 05.19.003 / 05.19.040 / 05.19.048

In vertical joints and centerlines for CH tray panels fixing.



REINFORCEMENT PLATE FOR HANGER

REF. 19.019

Used in forming together with rivets all hanging hooks corresponding to 40 mm wide vertical flange tray panels.



STB-CH SYSTEM

SYSTEM COMPONENTS

CASSETTE FORMING PLATE

REF. 05.19.050

Used in forming together with rivets, standard 45 mm wide vertical flange tray panel corners.



ANCHOR AND SCREW

REF. STB-T0800 / STB-T0801

For fixing the spacer to concrete or masonry. The specific load shall be checked by extraction test according to ETAG 020.



SCREW FIXING TO UPRIGHT

REF. STB-T0600 / STB-T0610

For attaching the **CH cassette** to the OMEGA profile.

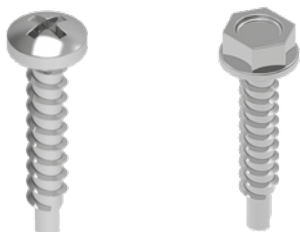

STIFFENER SCH

REF. 05.19.025 / 05.19.026 / 05.19.027 / 05.19.0271 / 05.19.27.2 / 05.19.27.3

Attaches to the back of the cassette with elastic adhesive. Enables the execution of larger cassettes.



SEPARATOR / MULLION FIXING SCREW

REF. STB-T0300 / STB-T0310 / STB-T0311 / STB-T0312

For fixing the upright to the spacer.



FORMED RIVET (*)

REF. STB-R0300

For cassette forming.

(*) Possibility of delivery lacquered



BRACKET SET STB-CH HANGING

The **STB-CH** hanger support set is the one used for the OMEGA profile.

The joint of the hanger piece is intended to prevent vibration noise caused by wind load, road traffic, etc.

This support is attached to the profile initially by means of tabs that allow vertical displacement to facilitate placement in its final position, and subsequently by means of self-drilling screws.

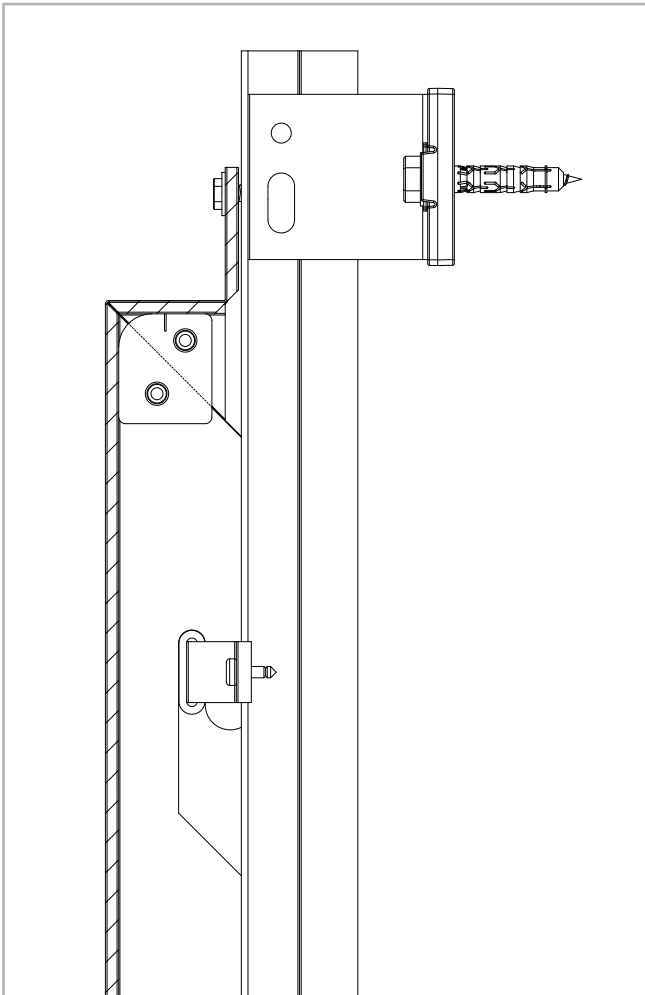
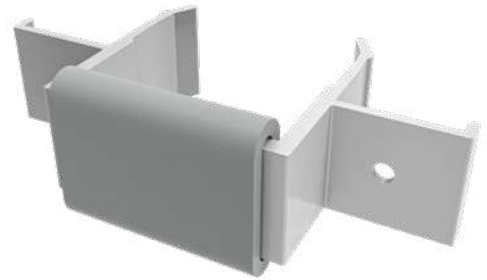

STB-CH SYSTEM

STANDARD CH WING CASSETTE 45 mm

STB-CH standard tray panel hooks are cut out during machining process so they can then be hung on previously installed hanging devices.

The cassette is formed by means of rivets and specific forming plates.

Once the cassette is in place, it is fixed to the upright by means of a self-drilling screw through the upper flange.

UNFOLDED CASSETTE

FORMED CASSETTE

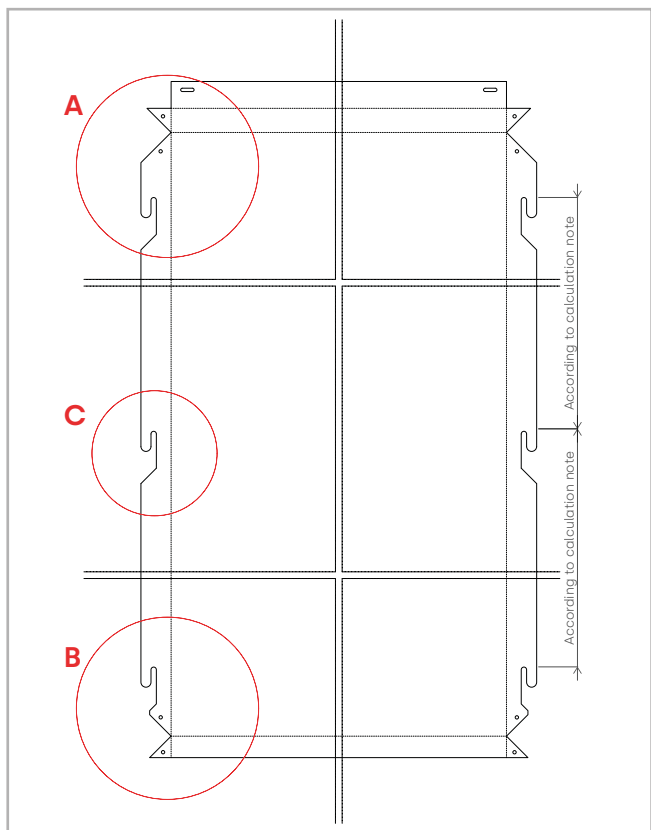

DETAIL A

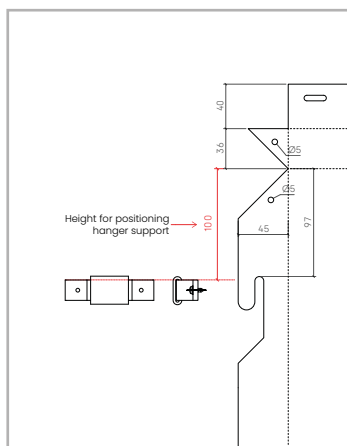

DETAIL B

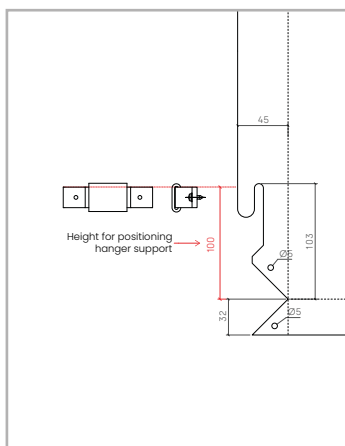

DETAIL C

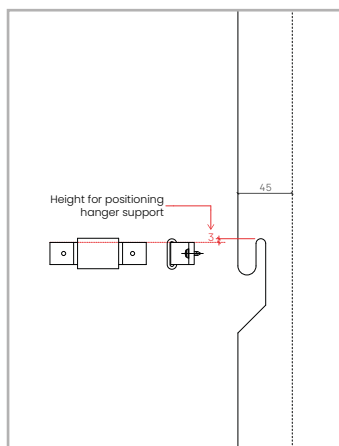

SEE CASSETTE FORMING VIDEO



STB-CH SYSTEM

STANDARD CH WING CASSETTE 40 mm

STB-CH standard tray panel hooks are cut out during machining process, in this case on 40mm wide vertical flaps so they can be hung on previously installed hanging devices.

The cassette is formed by means of rivets and specific hanging brackets, to be placed on all the footings of the cassette.

Once the cassette is in place, it is fixed to the upright by means of a self-drilling screw through the upper flange.

UNFOLDED CASSETTE

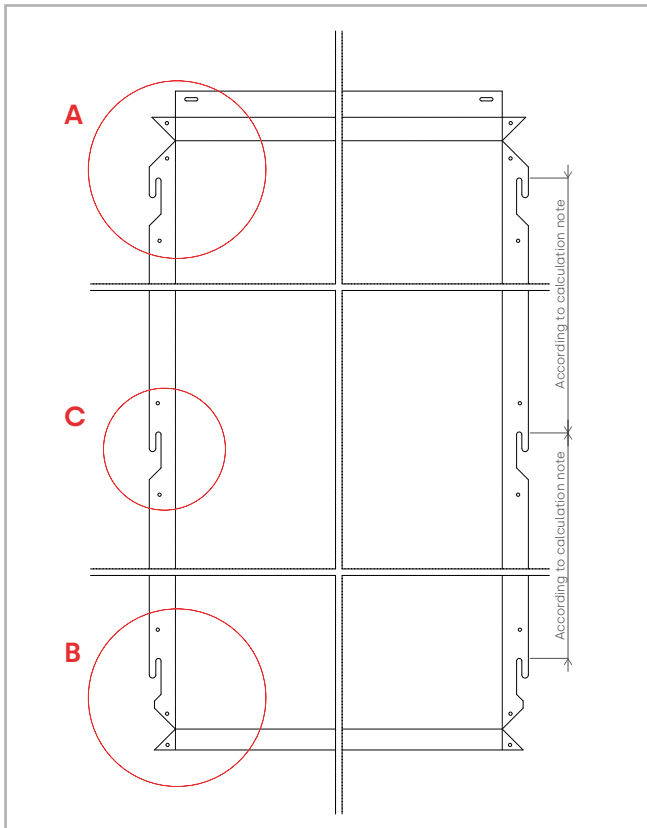

FORMED CASSETTE



DETAIL A

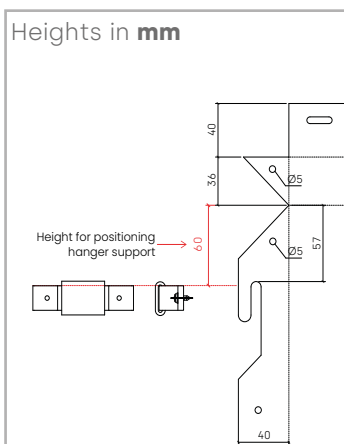

DETAIL B

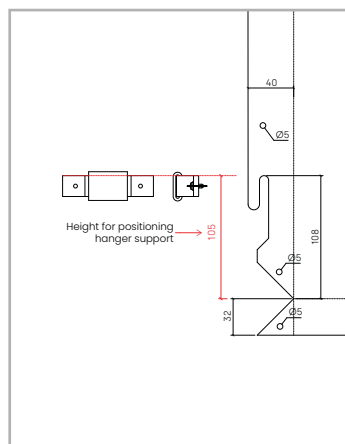

DETAIL C

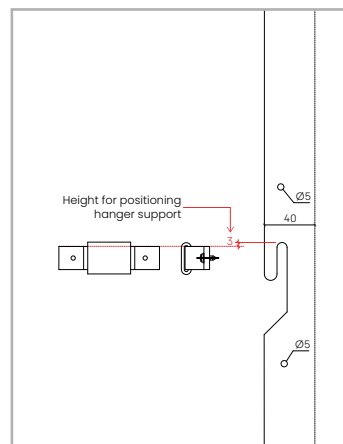

STB-CH SYSTEM

VERTICAL CASSETTE STIFFENER

VERTICAL STIFFENER

The vertical stiffener is a corner-shaped piece formed from machined **STACBOND** composite panel. It is used to reinforce CH cassettes, when they exceed certain dimensions. The stiffener is attached by double-sided tape and adhesive to the inside face of the cassette and riveted to the horizontal upper and lower flanges of the cassette.



1. PREPARATION OF THE AREA

Dust and dirt shall be removed using mechanical processes, which shall consist of more or less deep sanding, depending on the existing dirt. Once cleaned, the area shall be primed with a specific product that reinforces the adhesion of the elastic adhesive SIKATAACK PANEL PRIMER (or similar).

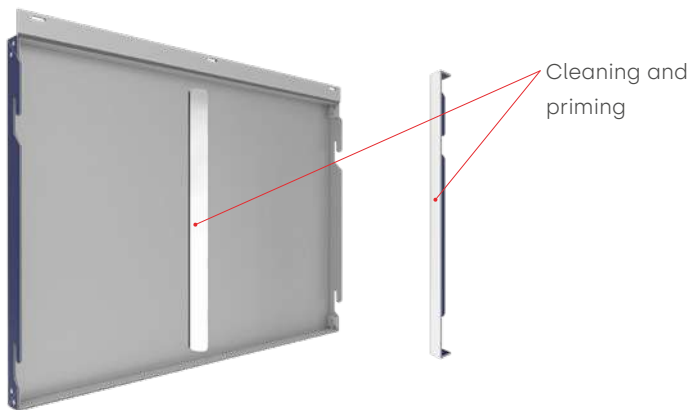

2. DOUBLE-SIDED ADHESIVE TAPE

After priming, the self-adhesive tape CINTA SIKATAACK PANEL-3 (or similar) shall be applied. Subsequently, the elastic adhesive SIKATAACK PANEL 50 (or similar) shall be spread over cassette surface by applying a continuous bead adjacent to the double-sided tape.

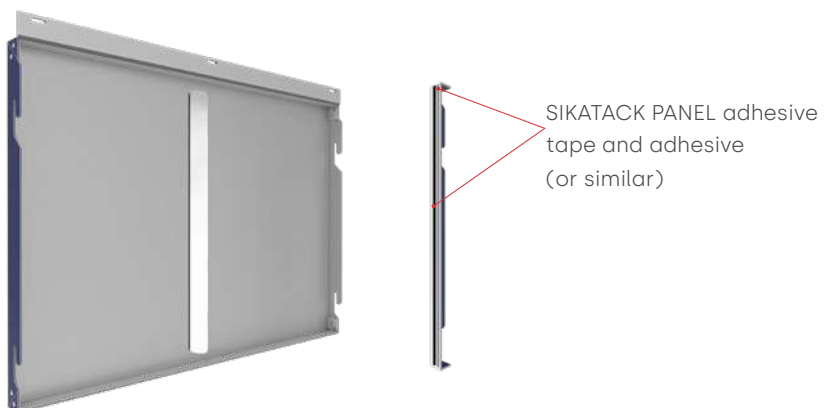

3. FITTING AND FIXING OF THE STIFFENER

The stiffener shall then be placed in such a way that the entire surface of the stiffener is impregnated with adhesive. Finally the stiffener shall be drilled and riveted at the top and bottom against the horizontal flanges of the cassette.

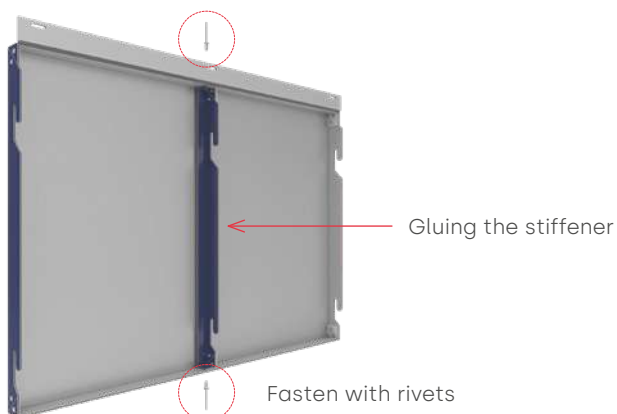

INSULATING WEDGES

REF.	COMPONENT
05.19.067	INSULATING WEDGE FOR SPACERS U WITH REF: 05.19.046 / 05.19.047
05.19.069	INSULATING WEDGE FOR SPACERS DOUBLE T WITH REF: 05.19.030 / 05.19.031 / 05.19.032 / 05.19.033 / 05.19.034 / 05.19.035 / 05.19.036 / 05.19.037 / 05.19.038 / 05.19.039
05.19.073	INSULATING WEDGE FOR SPACERS DOUBLE T WITH REF: 05.19.004 / 05.19.005 / 05.19.006 / 05.19.007
05.19.071	3 x GROOVE WASHERS FOR SPACERS L WITH REF: 05.19.067 / 05.19.069 / 05.19.073

SPACERS

REF.	COMPONENT
05.19.004	SPACER DOUBLE T 57
05.19.005	SPACER DOUBLE T 72
05.19.006	SPACER DOUBLE T 87
05.19.007	SPACER DOUBLE T 102
05.19.030	SPACER DOUBLE T 117
05.19.031	SPACER DOUBLE T 132
05.19.032	SPACER DOUBLE T 147
05.19.033	SPACER DOUBLE T 162
05.19.034	SPACER DOUBLE T 177
05.19.035	SPACER DOUBLE T 192
05.19.036	SPACER DOUBLE T 207
05.19.037	SPACER DOUBLE T 222
05.19.038	SPACER DOUBLE T 237
05.19.039	SPACER DOUBLE T 252
05.19.046	SPACER U 57
05.19.047	SPACER U 72

PROFILES

REF.	COMPONENT
05.19.003	OMEGA PROFILE (2 mm)
05.19.040	OMEGA PROFILE (2.5 mm)
05.19.048	PROFILE OMEGA LIGHT

ADDITIONAL COMPONENTS

REF.	COMPONENT
05.19.013	BRACKET SET STB-CH HANGING
19.019	REINFORCEMENT PLATE FOR HANGER
05.19.050	CASSETTE FORMING PLATE
05.19.025	STIFFENER SCH-1 (< 750 mm)
05.19.026	STIFFENER SCH-2 (750 - 1.500 mm)
05.19.027	STIFFENER SCH-3 (1.500 - 2.400 mm)
05.19.027.1	STIFFENER SCH-4 (2.400 - 4.000 mm)
05.19.027.2	STIFFENER SCH-5 (4.000 - 5.000 mm)
05.19.027.3	STIFFENER SCH-6 (> 5.000 mm)

FIXING ACCESSORIES

REF.	COMPONENT
STB-T0800	ANCHOR + SCREW SET FOR FIXING BRACKET TO WALL X3 10X80 HEX. 3DG WIDE NECK
STB-T0801	ANCHOR + SCREW SET FOR FIXING BRACKET TO WALL SDF-KB-10X80-E A4 STAINLESS STEEL WIDE NECK
STB-T0300	SELF-TAPPING SCREW SDA5/3.5-6-H13-SA-5.5X20
STB-T0310	SLIDING POINT BRACKET-PROFILE FIXING SCREW JT9-2/5-5.0x25 VARIO STAINLESS STEEL A4
STB-T0311	DRILL BIT JT4-3H/5-5.5x19 INOX-A2 - FIXED POINT
STB-T0312	DRILL BIT JT9-3H/5-5.5x19 INOX-A4 - FIXED POINT
STB-T0600	SELF-DRILLING SCREW 4.2x19 STAINLESS STEEL A2 DIN 7504-N ROUNDED CYLINDRICAL HEAD
STB-T0610	SELF-DRILLING SCREW 4.2x19 STAINLESS STEEL A2 DIN 7504-K HEXAGONAL HEAD
STB-R0300	ALU/SS RIVET Ø4.8X12, D.HEAD 9.5



See all available accessories on page 131

STB-CH SYSTEM

TOTAL THICKNESS RATIO, ACCORDING TO SPACERS AND INSULATOR

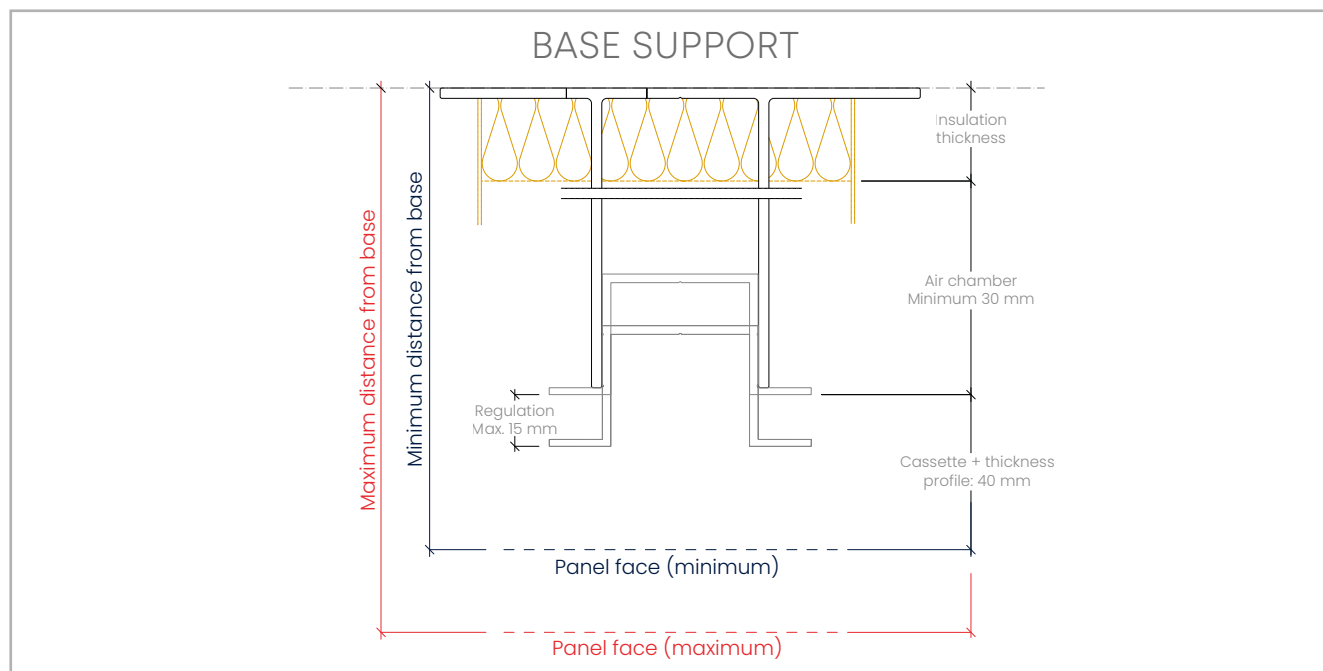

Note: the use of insulating wedges will increase the distance to the outer face of the panel by 5 mm.

SPACER DOUBLE T		DISTANCE (mm) FROM THE BASE OF THE ANCHORING TO EXPOSED PANEL FACE		INSULATING THICKNESS (mm) FOR 15 mm ADJUSTMENT*
REF.	COMPONENT	MINIMUM	MAXIMUM	MAXIMUM
05.19.004	SPACER DOUBLE T 57	100	115	—
05.19.005	SPACER DOUBLE T 72	115	130	40
05.19.006	SPACER DOUBLE T 87	130	145	50
05.19.007	SPACER DOUBLE T 102	145	160	70
05.19.030	SPACER DOUBLE T 117	160	175	80
05.19.031	SPACER DOUBLE T 132	175	190	100
05.19.032	SPACER DOUBLE T 147	190	205	110
05.19.033	SPACER DOUBLE T 162	205	220	130
05.19.034	SPACER DOUBLE T 177	220	235	140
05.19.035	SPACER DOUBLE T 192	235	250	160
05.19.036	SPACER DOUBLE T 207	250	265	170
05.19.037	SPACER DOUBLE T 222	265	280	190
05.19.038	SPACER DOUBLE T 237	280	295	200
05.19.039	SPACER DOUBLE T 252	295	310	220

SPACER U		DISTANCE (mm) FROM THE BASE OF THE ANCHORING TO EXPOSED PANEL FACE		INSULATING THICKNESS (mm) FOR 15 mm ADJUSTMENT*
REF.	COMPONENT	MINIMUM	MAXIMUM	MAXIMUM
05.19.046	SPACER U 57	100	115	—
05.19.047	SPACER U 72	115	130	40

* For the calculation of the maximum admissible thickness, rigid insulation has been taken into account, guaranteeing the maximum regulation of each system and maintaining an air gap of ≥ 30 mm.

STB-SZ

MALE-FEMALE SYSTEM

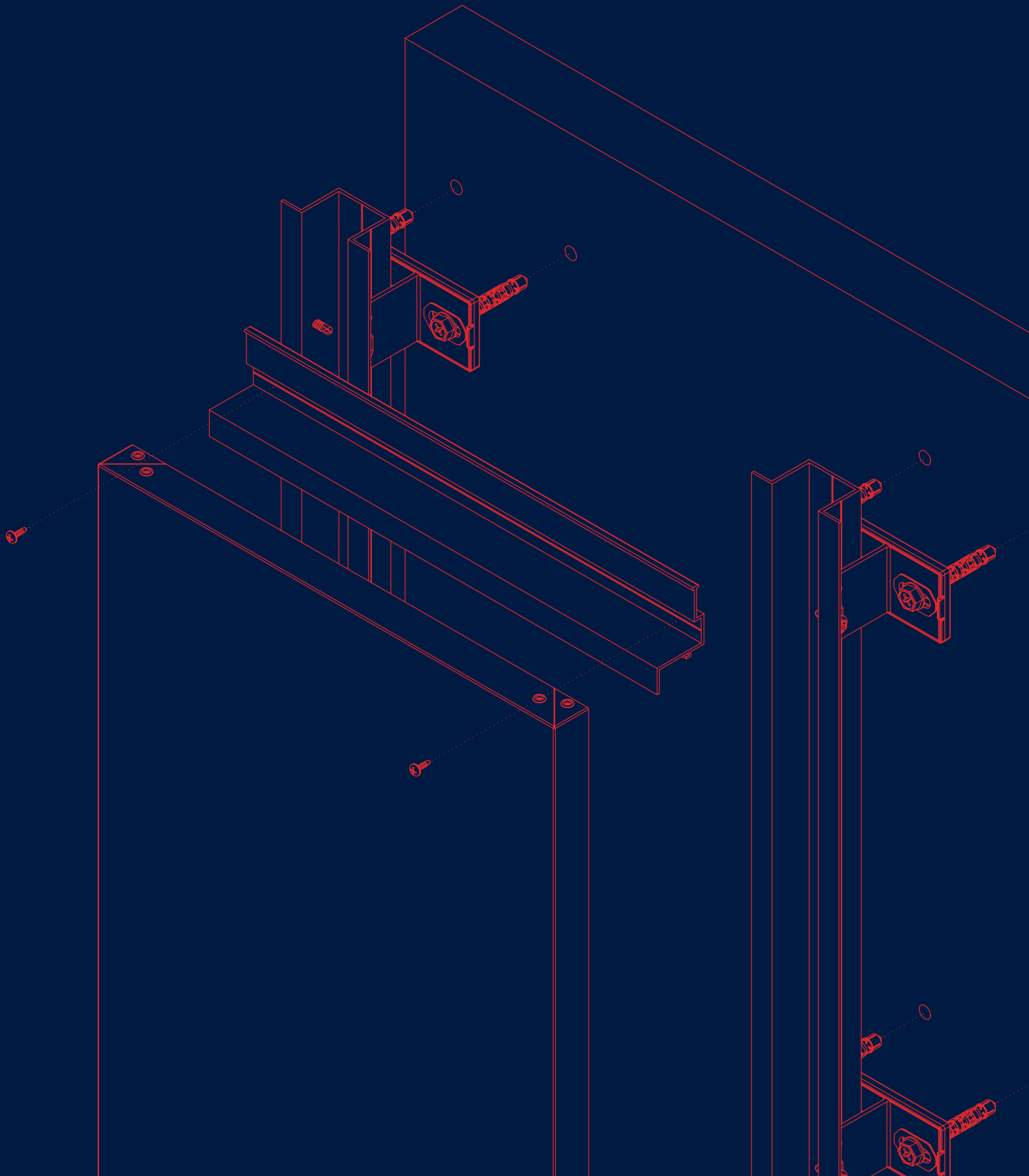

SEE ASSEMBLY VIDEO



STB-SZ evo®



System compatible with horizontal stiffener and bottom clip.

See installation instructions on page 58

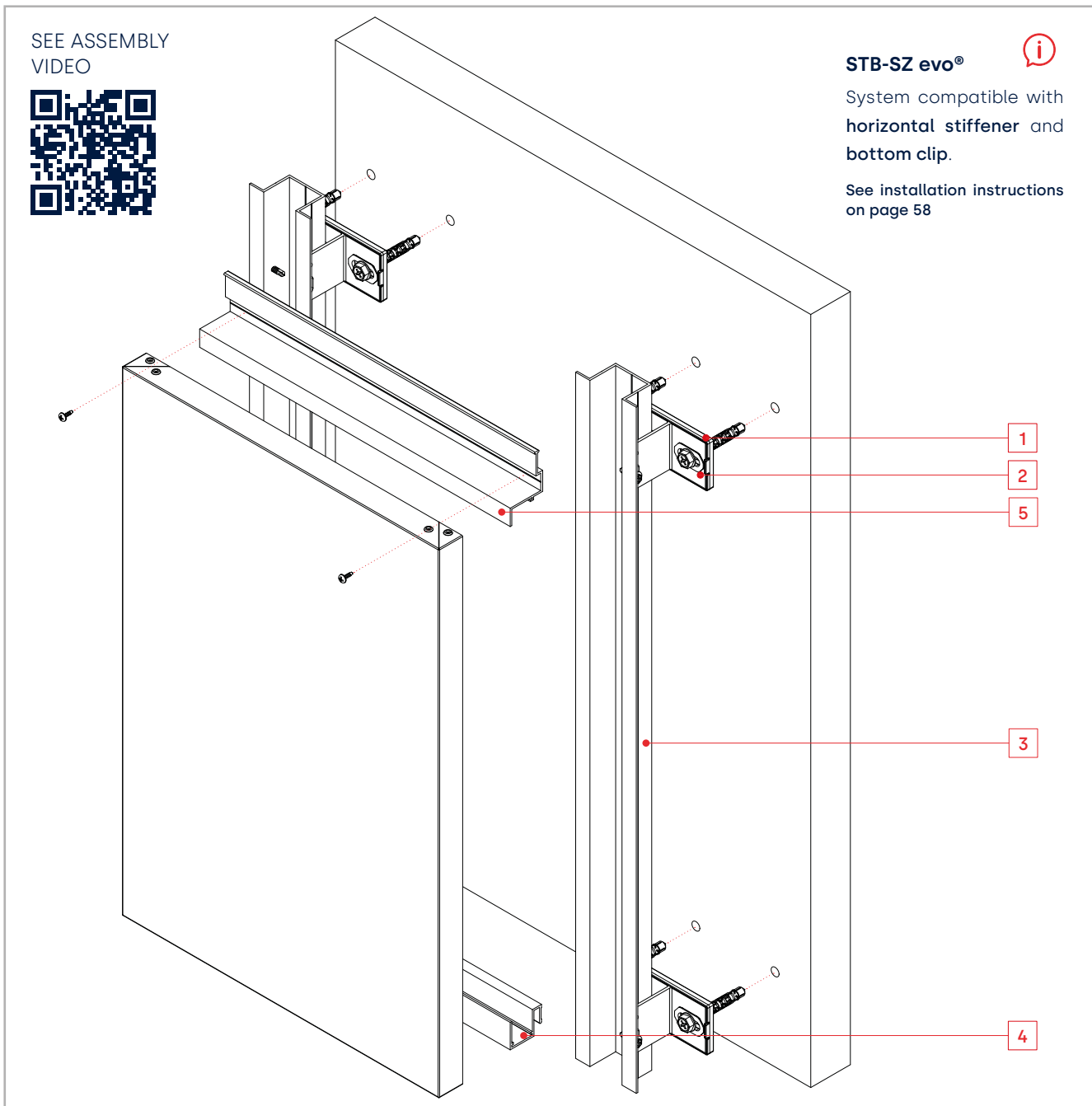

The **STB-SZ** is a kit system based on **STACBOND composite panel cassettes for the assembly of ventilated façades**. It is a tongue and groove system with concealed fixing, versatile and quick to assemble, specially designed to develop façades with horizontal or vertical modulation, with predominantly blind parts and/or little surface area of openings or linear openings.

It consists of two 6063 T5/T6 aluminium alloy profiles 6063 T5/T6 on which the already formed cassettes are anchored:

- Lower female profile, so-called **S-profile**.
- Upper male profile, so-called **Z-profile**.

The substructure is made of **OMEGA profiles** and **spacers DOUBLE T** made of 6063 T5/T6 aluminium alloy.

These spacers have different lengths to accommodate the required thickness of thermal insulation and to absorb all the irregularities of the façade. For the thermal bridge break, **STAC** has developed specific **INSULATING WEDGES** to be placed between the spacers L and the wall facing.

INSULATING WEDGE AND GROOVE WASHER (1)

REF. 05.19.067 / 05.19.069 / 05.19.073

REF. 05.19.071

Optional insulating wedges and insulation covers, for eliminating thermal bridges in spacers.

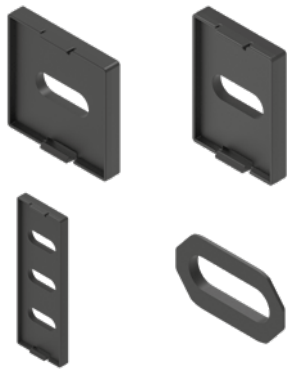

SPACER U

REF. 05.19.046 / 05.19.047

For profile and system fixing to the bracket. Available in different sizes depending on the desired system thickness.



S PROFILE (4)

REF. 05.19.121

It is installed in the lower part of the SZ cassette.

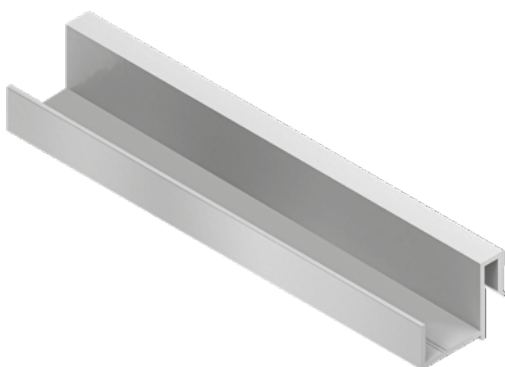

SPACER DOUBLE T (2)

REF. 05.19.004 / 05.19.005 / 05.19.006 / 05.19.007 / 05.19.030 /

05.19.031 / 05.19.032 / 05.19.033 / 05.19.034 / 05.19.035 /

05.19.036 / 05.19.037 / 05.19.038 / 05.19.039

For profile and system fixing to the bracket. Available in different sizes depending on the desired system thickness.

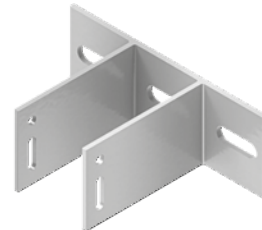

OMEGA PROFILE (3)

REF. 05.19.003 / 05.19.040 / 05.19.048

In vertical joints and centerlines for SZ tray panels fixing.



Z PROFILE (5)

REF. 05.19.122

It is installed on top of the SZ cassette.

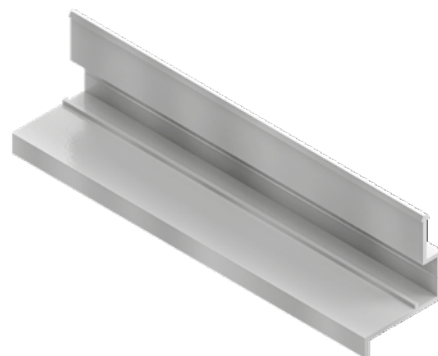

STB-SZ SYSTEM

SYSTEM COMPONENTS

REINFORCEMENT STB-SZ

REF. 05.99.231

It is fixed upon the stud and glued to the back of the tray panel in order to be able to produce cassettes with greater vertical dimension.

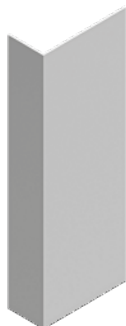

ANCHOR AND SCREW

REF. STB-T0800 / STB-T0801

For fixing spacer to concrete or masonry. The specific load shall be checked by extraction test according to ETAG 020.



SCREW FIXING TO UPRIGHT

REF. STB-T0600 / STB-T0610

For attaching the **SZ cassette** to the OMEGA profile.

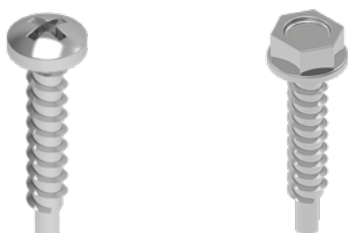

PIECE OF GASKET JOINT

REF. 05.19.123

To be fitted to starter profile and Z profile.



SEPARATOR / MULLION FIXING SCREW

REF. STB-T0300 / STB-T0310 / STB-T0311 / STB-T0312

For fixing the upright to the spacer.



FORMED RIVET (*)

REF. STB-R0300

For cassette forming.

(*) Possibility of delivery lacquered



STB-SZ SYSTEM

SZ CASSETTE FIXING

UPPER ANCHORAGE



VERTICAL SECTION

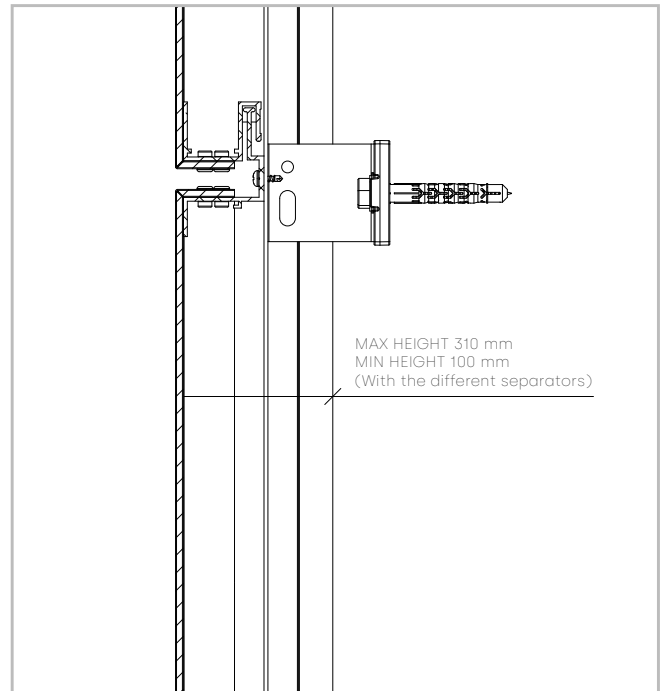

LOWER ANCHORAGE



VERTICAL SECTION

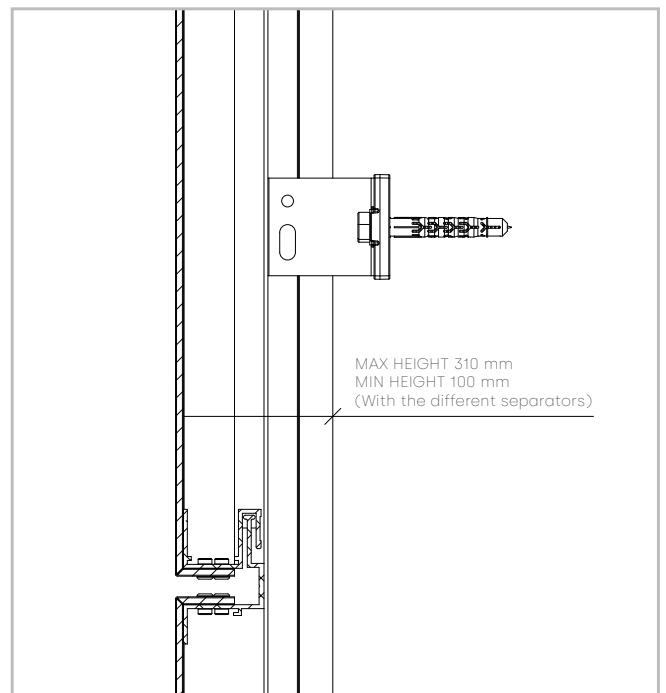

Note: **STACBOND** panels are supplied flat. The customer is responsible for cassette forming. No specific machines are needed.

STB-SZ SYSTEM

ADDITIONAL COMPONENTS

S-PROFILE AND Z-PROFILE

The STB-SZ system consists of two 6063 T5/T6 aluminium alloy profiles on which the pre-formed cassettes are anchored.

- Lower female profile, so-called **S-profile**.
- Upper male profile, so-called **Z-profile**.

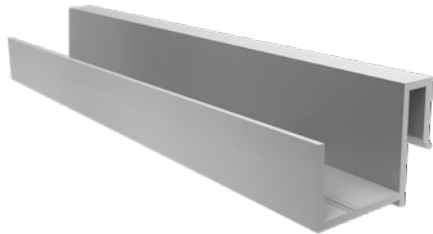

– S-Profile

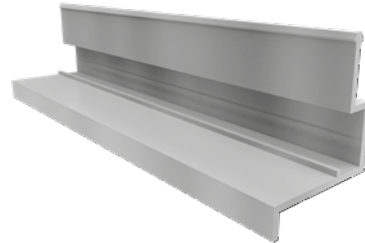

– Z-Profile

REINFORCEMENT STB-SZ

The STB-SZ reinforcement is a specific 200 mm long segmented profile covering the inner equidistance from the SZ formed cassette to the substructure.

The fastening of this component to the substructure profile is done by riveting or screwing.

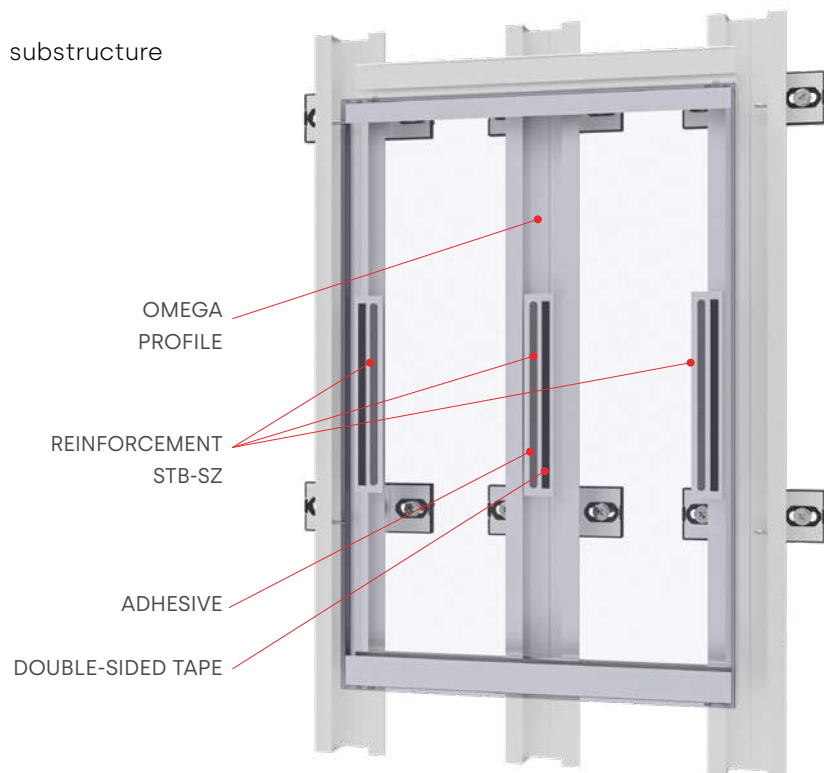
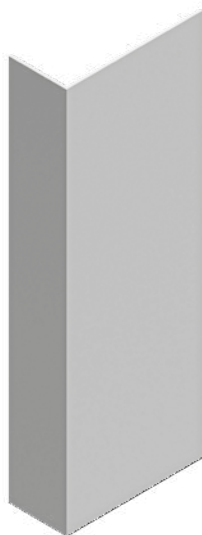

The amount of STB-SZ reinforcements will be indicated in the wind calculation note issued by **STACBOND** technical office.

PIECE OF GASKET JOINT

The co-extruded gap seal is easily installed in the **Z-profile** with a maximum gap of 500 mm.

This avoids possible vibrations between cassettes, and facilitates the adjustment of cassettes to ensure the correct levelling of the pieces.

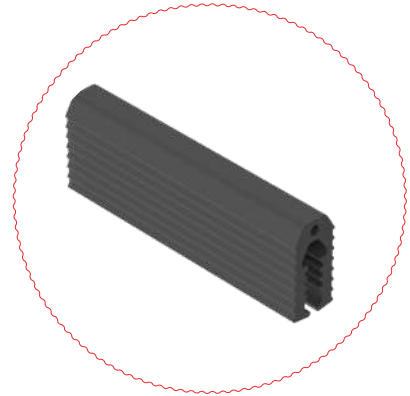
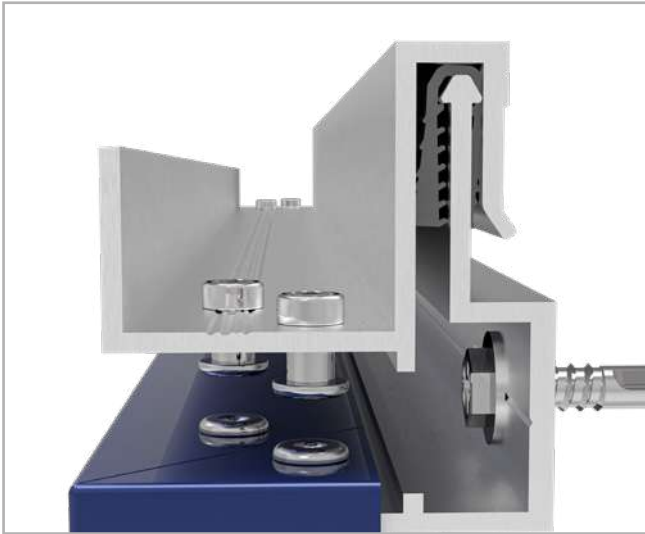
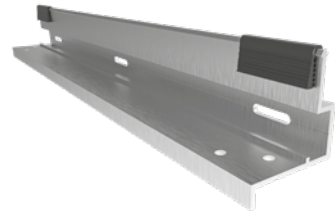

– Assembly of S and Z profiles.



STB-SZ SYSTEM

STANDARD SZ CASSETTE

The standard cassettes of the **STB-SZ** system have 30 mm flanges. They are mechanically fastened by means of rivets directly onto the longitudinal profiles S and Z for forming.

The **S-profile** is placed at the bottom and the **Z-profile** at the top of the cassette. The profiles provide high longitudinal rigidity to the cassettes.

UNFOLDED CASSETTE

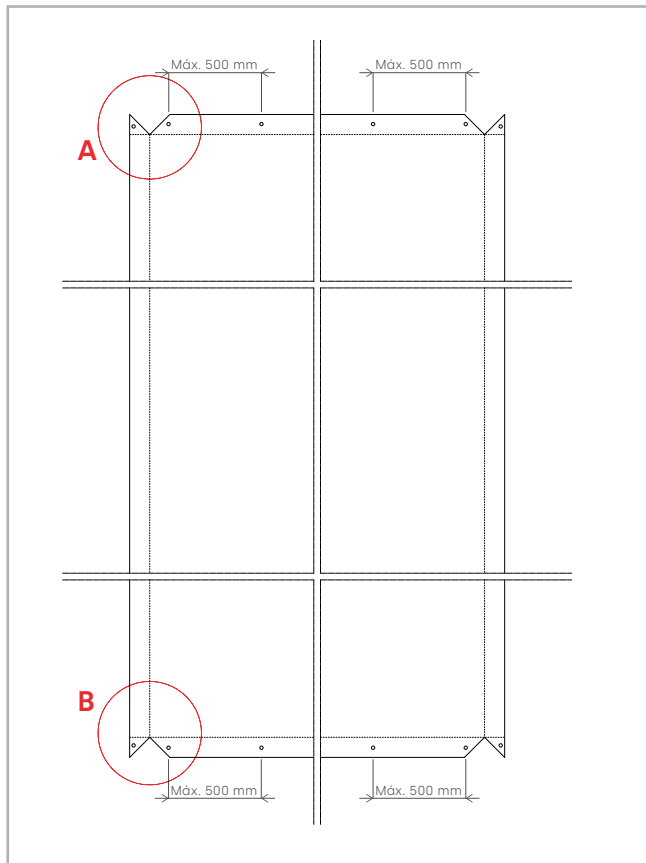

FORMED CASSETTE



DETAIL A

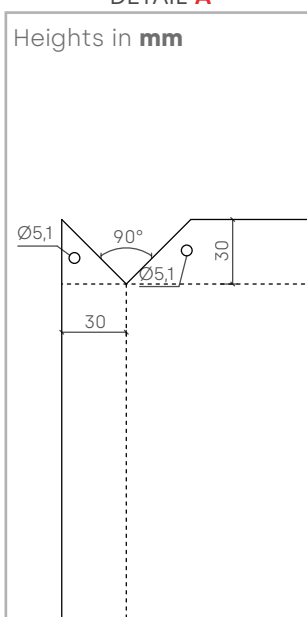

DETAIL B

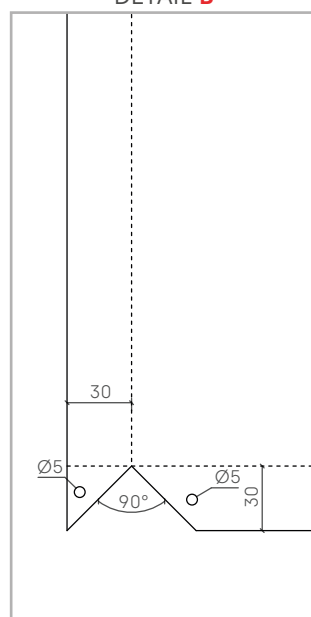

SEE CASSETTE
FORMING
VIDEO



INSULATING WEDGES

REF.	COMPONENT
05.19.067	INSULATING WEDGE FOR SPACERS U WITH REF: 05.19.046 / 05.19.047
05.19.068	INSULATING WEDGE FOR SPACERS L WITH REF: 05.19.030 / 05.19.031 / 05.19.032 / 05.19.033 / 05.19.034 / 05.19.035 / 05.19.036 / 05.19.037 / 05.19.038 / 05.19.039
05.19.072	INSULATING WEDGE FOR SPACERS L WITH REF: 05.19.041 / 05.19.044 / 05.19.051 / 05.19.052 / 05.19.078 / 05.19.079 / 05.19.080 / 05.19.081
05.19.070	3 x GROOVE WASHERS FOR SPACERS L WITH REF: 05.19.066 / 05.19.068 / 05.19.072

SPACERS

REF.	COMPONENT
05.19.004	SPACER DOUBLE T 57
05.19.005	SPACER DOUBLE T 72
05.19.006	SPACER DOUBLE T 87
05.19.007	SPACER DOUBLE T 102
05.19.030	SPACER DOUBLE T 117
05.19.031	SPACER DOUBLE T 132
05.19.032	SPACER DOUBLE T 147
05.19.033	SPACER DOUBLE T 162
05.19.034	SPACER DOUBLE T 177
05.19.035	SPACER DOUBLE T 192
05.19.036	SPACER DOUBLE T 207
05.19.037	SPACER DOUBLE T 222
05.19.038	SPACER DOUBLE T 237
05.19.039	SPACER DOUBLE T 252
05.19.046	SPACER U 57
05.19.047	SPACER U 72

PROFILES

REF.	COMPONENT
05.19.003	OMEGA PROFILE
05.19.121	S PROFILE
05.19.122	Z PROFILE

ADDITIONAL COMPONENTS

REF.	COMPONENT
05.99.231	REINFORCEMENT STB-SZ
05.19.123	PIECE OF GASKET JOINT

FIXING ACCESSORIES

REF.	COMPONENT
STB-T0800	ANCHOR + SCREW SET FOR FIXING BRACKET TO WALL X3 10X80 HEX. 3DG WIDE NECK
STB-T0801	ANCHOR + SCREW SET FOR FIXING BRACKET TO WALL SDF-KB-10X80-E A4 STAINLESS STEEL WIDE NECK
STB-T0300	SELF-TAPPING SCREW SDA5/3.5-6-H13-SA- 5.5X20
STB-T0310	SLIDING POINT BRACKET-PROFILE FIXING SCREW JT9-2/5-5.0x25 VARIO STAINLESS STEEL A4
STB-T0311	DRILL BIT JT4-3H/5-5.5x19 INOX-A2 - FIXED POINT
STB-T0312	DRILL BIT JT9-3H/5-5.5x19 INOX-A4 - FIXED POINT
STB-T0600	SELF-DRILLING SCREW 4.2x19 STAINLESS STEEL A2 DIN 7504-N ROUNDED CYLINDRICAL HEAD
STB-T0610	SELF-DRILLING SCREW 4.2x19 STAINLESS STEEL A2 DIN 7504-K HEXAGONAL HEAD
STB-R0300	ALU/SS RIVET Ø4.8X12, D.HEAD 9.5

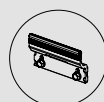

See all available accessories on
page 131

STB-SZ SYSTEM

TOTAL THICKNESS RATIO, ACCORDING TO SPACERS AND INSULATOR

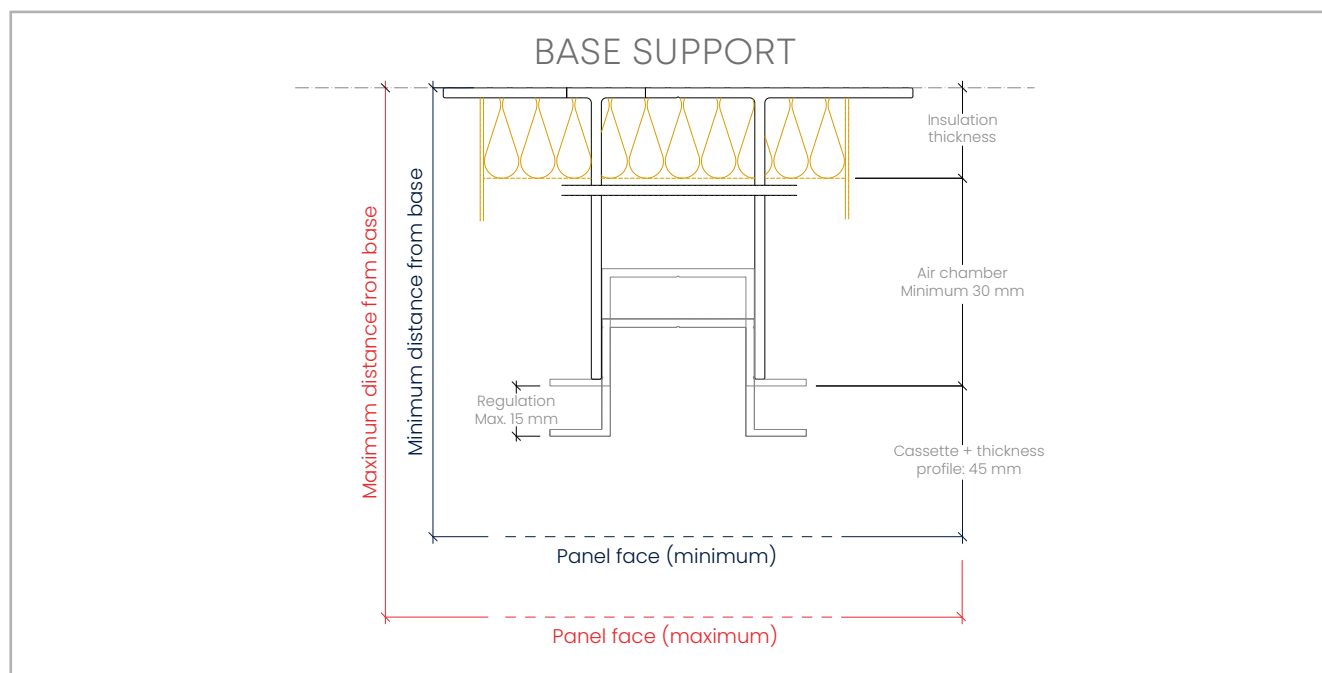

Note: the use of insulating wedges will increase the distance to the outer face of the panel by 5 mm.

SPACER DOUBLE T		DISTANCE (mm) FROM THE BASE OF THE ANCHORING TO EXPOSED PANEL FACE		INSULATING THICKNESS (mm) FOR 15 mm ADJUSTMENT*
REF.	COMPONENT	MINIMUM	MAXIMUM	MAXIMUM
05.19.004	SPACER DOUBLE T 57	104	119	—
05.19.005	SPACER DOUBLE T 72	119	134	40
05.19.006	SPACER DOUBLE T 87	134	149	50
05.19.007	SPACER DOUBLE T 102	149	164	70
05.19.030	SPACER DOUBLE T 117	164	179	80
05.19.031	SPACER DOUBLE T 132	179	194	100
05.19.032	SPACER DOUBLE T 148	194	209	110
05.19.033	SPACER DOUBLE T 162	209	224	130
05.19.034	SPACER DOUBLE T 177	224	239	140
05.19.035	SPACER DOUBLE T 192	239	254	160
05.19.036	SPACER DOUBLE T 207	254	269	170
05.19.037	SPACER DOUBLE T 222	269	284	190
05.19.038	SPACER DOUBLE T 237	284	299	200
05.19.039	SPACER DOUBLE T 252	299	314	220

SPACER U		DISTANCE (mm) FROM THE BASE OF THE ANCHORING TO EXPOSED PANEL FACE		INSULATING THICKNESS (mm) FOR 15 mm ADJUSTMENT*
REF.	COMPONENT	MINIMUM	MAXIMUM	MAXIMUM
05.19.046	SPACER U 57	104	119	—
05.19.047	SPACER U 72	119	134	40

*For the calculation of the maximum admissible thickness, rigid insulation has been taken into account, guaranteeing the maximum regulation of each system and maintaining an air gap of ≥ 30 mm.

STB-REM

RIVETED SYSTEM

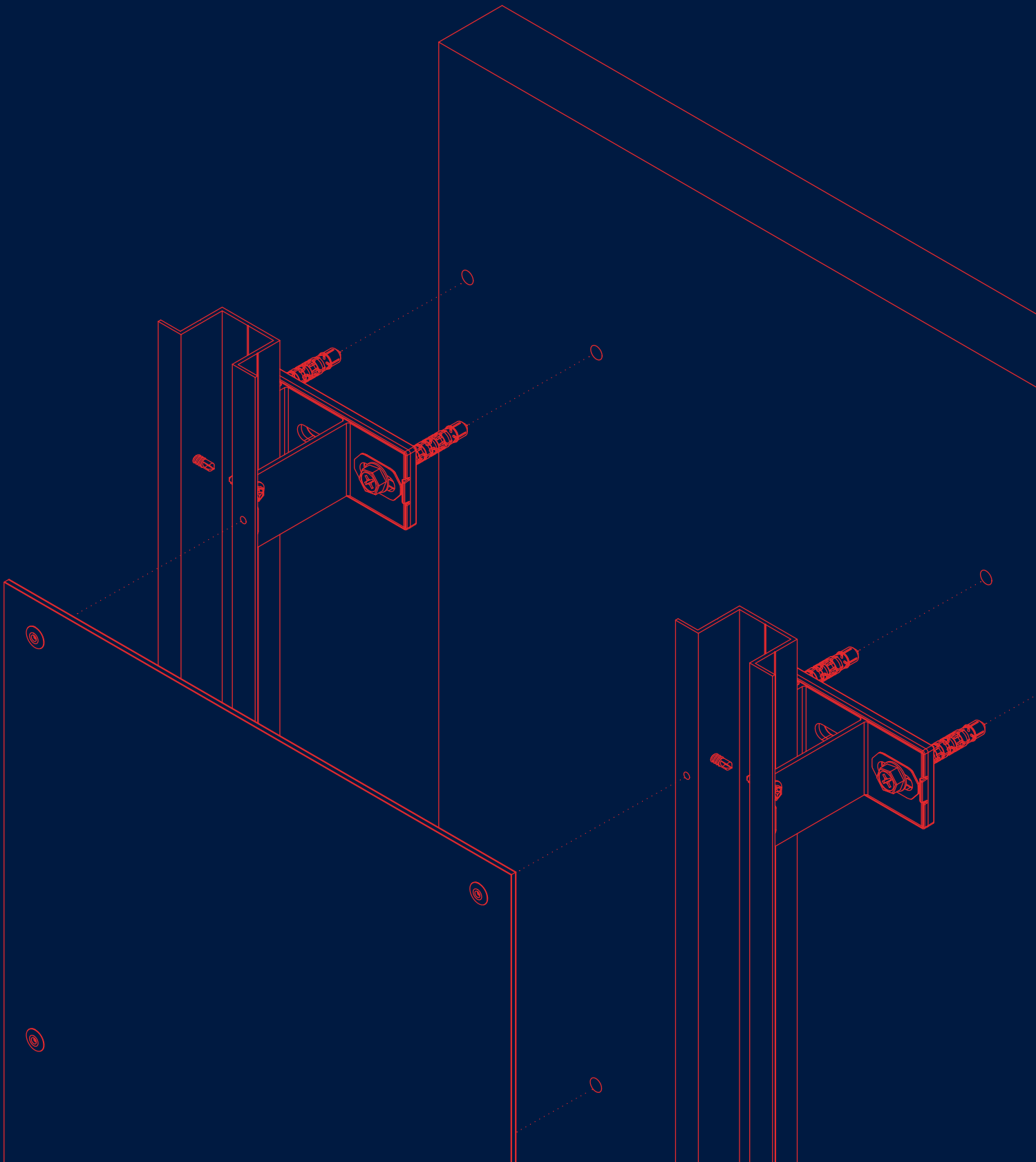

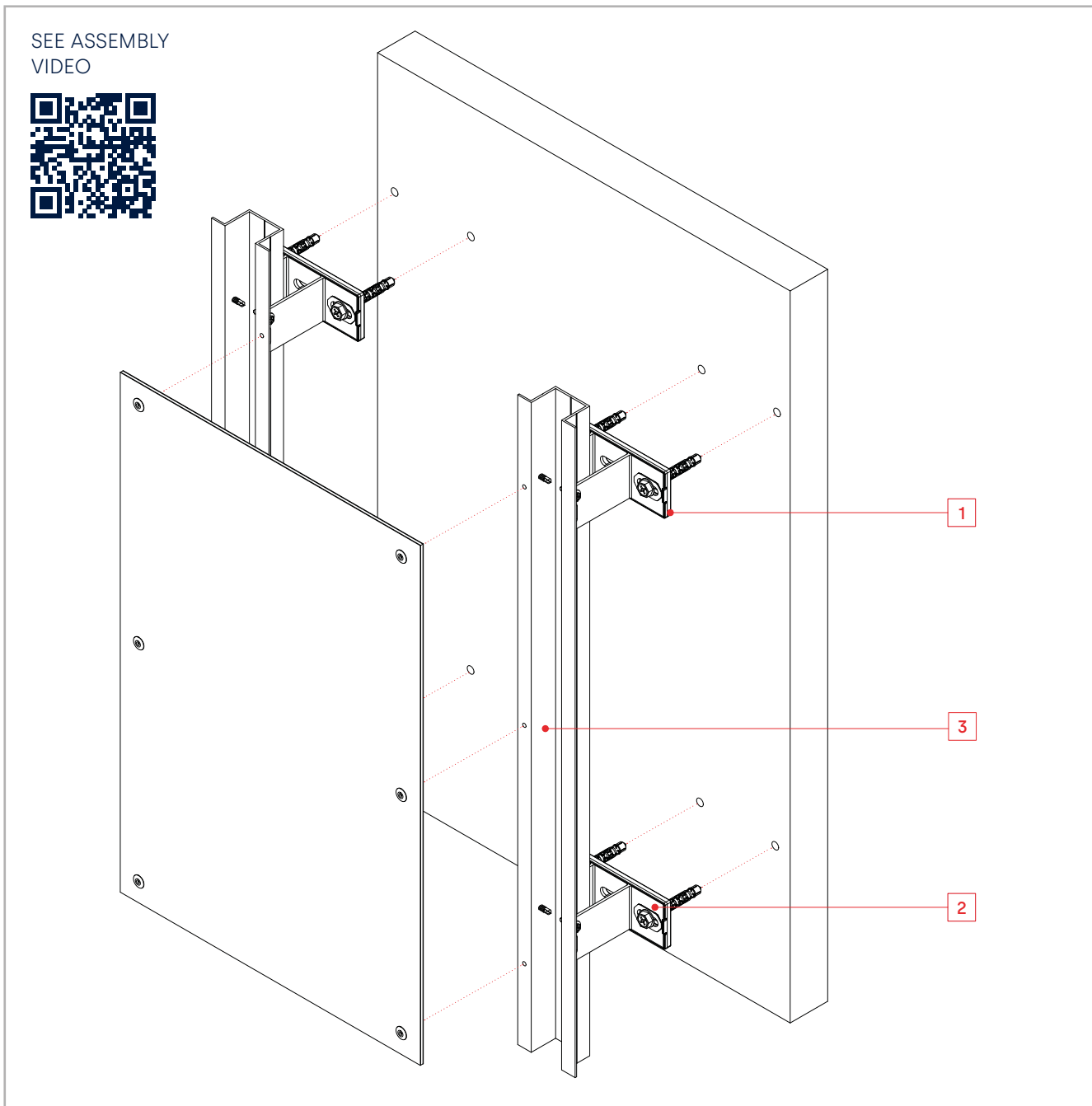

The **STB-REM** is a kit system of unformed panels from **STACBOND composite panels for the assembly of ventilated façades**. It is an exposed fastening system that is quick to assemble and can be used for both horizontal and vertical cut-outs. It is a very versatile system that is adaptable and offers the possibility to execute curved areas in a simple way. Therefore, the **STB-REM** system meets all the requirements for the most demanding architectural coatings.

The substructure is made of **OMEGA profiles** and **spacers DOUBLE T** in aluminium alloy 6063 T5/T6 or INOX AISI 430.

The spacers are anchored to the wall by means of special mechanical fasteners, recommended in each case by fastener suppliers, and are supported by OMEGA profiles as vertical uprights.

This substructure of vertical and/or horizontal OMEGA profiles supports the **STACBOND** composite panel sheets which are riveted around the perimeter.

The **STB-REM** system complies with the main international certifications.

INSULATING WEDGE AND GROOVE WASHER (1)

REF. 05.19.067 / 05.19.069 / 05.19.073

REF. 05.19.071

Optional insulating wedges and insulation covers, for eliminating thermal bridges in spacers.

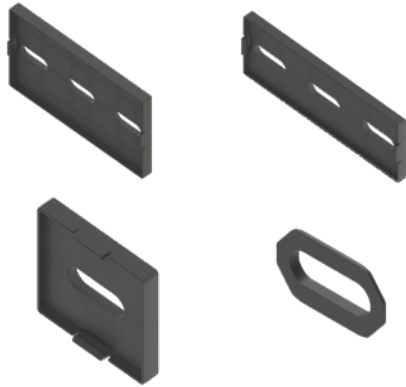

SPACER U

REF. 05.19.046 / 05.19.047

For profile and system fixing to the bracket.

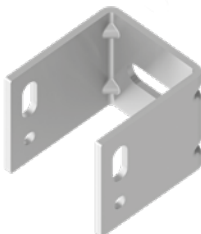

STB-REM UPRIGHT CONNECTION

REF. 05.19.020

For connecting upright and cross-member profiles with OMEGA cross-section in bi-directional installation.



SPACER DOUBLE T (2)

REF. 05.19.004 / 05.19.005 / 05.19.006 / 05.19.007 / 05.19.030 / 05.19.031 / 05.19.032 / 05.19.033 / 05.19.034 / 05.19.035 / 05.19.036 / 05.19.037 / 05.19.038 / 05.19.039

For profile and system fixing to the bracket. Available in different sizes depending on the desired system thickness.

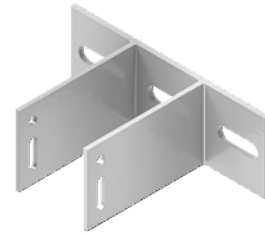

OMEGA PROFILE (3)

REF. 05.19.003

In vertical joints and centerlines for **STACBOND composite panels** fixing.



ANCHOR AND SCREW

REF. STB-T0800 / STB-T0801

For fixing the spacer to concrete or masonry. The specific load shall be checked by extraction test according to ETAG 020.



STB-REM SYSTEM

SYSTEM COMPONENTS

SPACER / UPRIGHT FIXING SCREW

REF. STB-T0300 / STB-T0310 / STB-T0311 / STB-T0312

For fixing the upright to the spacer.



BLIND RIVET

REF. STB-R0100

For fixing **STACBOND** composite panels on STB-REM substructures.

(* Possibility of delivery lacquered



STAINLESS STEEL BLIND RIVET

REF. STB-R0200

For fixing **STACBOND** panels on STB-REM substructures for high chloride exposure environments.



SAFETY SCREW

REF. STB-T0100

For fixing panels on structures STB-REM.

(* Possibility of delivery lacquered



NOZZLE FOR RIVETING MACHINE

REF. STB-FIJA-201 / STB-FIJA-202

Allows to limit the clamping force of the rivet head against the panel.

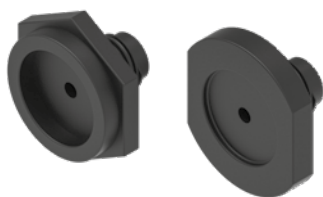

DOUBLE DRILL BIT

REF. STB-FIJA-203

Allows simultaneous drilling of the panel to 7 mm diameter and the substructure to 5.1 mm diameter.



DEPTH STOP

REF. STB-FIJA-204

Together with the double bit it allows to limit the thickness of the 7 mm hole in the panel.



CENTERING DEVICE

REF. STB-FIJA-205 / STB-FIJA-206 / STB-FIJA-207

To drill a 5.1 mm hole in the substructure centred on the sliding points of the panel.



DRIVER BIT

REF. STB-FIJA-208

For fixing the safety screw.



MANUAL CENTERING DEVICE

REF. STB-FIJA-209

For centring the safety screw in the sliding points of the panel.



STB-REM SYSTEM

ADDITIONAL COMPONENTS

STB-REM UPRIGHT CONNECTION

Formed part in folded aluminium sheet of alloy 1050-H and thickness 3 mm, with perforations for joining upright and cross-member profiles with OMEGA cross-section.

This accessory allows the connection of the horizontal OMEGA profiles to the substructure and can reduce the use of anchors to the base wall.

It is fixed by means of a $\varnothing 4.8$ mm blind rivet or $\varnothing 4.8$ mm self-drilling screws. These connection solutions are compatible with the possible expansions of the substructure.



PANEL EXPANSION

The composite panel, being largely composed of aluminium, is **subject to expansion and contraction due to temperature changes**.

To place the panel in the exact desired position, the panel should initially be riveted at **1 or 2 fixed points**, with holes in the panel of **5.1 mm diameter**, the location of which should **minimise the expansion of the panel in all directions**.

To avoid possible problems due to this phenomenon, and to absorb possible expansion, the rest of the holes in the panel should be **sliding points**: i.e. if the rivet body diameter is 5 mm, the **hole in the panel should be 7 to 8.5 mm in diameter**.

It is also important that the 5.1 mm drill hole in the substructure and thus the positioning of the rivets is **perfectly centred on the sliding points**, in order to allow for equal expansion in all directions. We use **centring devices** for this purpose.

In addition, in order not to block the expansion of the panel, it is important to **limit the clamping force of the rivet head against the panel**. This is achieved by using riveting machine **nozzles** to **maintain a 0.2 mm gap** between the rivet head and the panel.

CORRECT INSTALLATION *

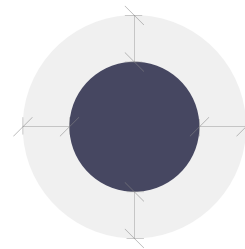

Drill hole in the substructure centred

INCORRECT INSTALLATION

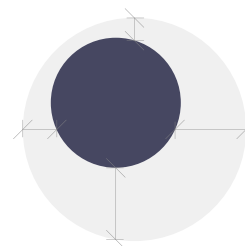

Hole in the substructure not centred

* Tools to be used **centring tool** and **nozzle for riveting tool**. See pages 118 and 119.

STB-REM SYSTEM

ADDITIONAL COMPONENTS

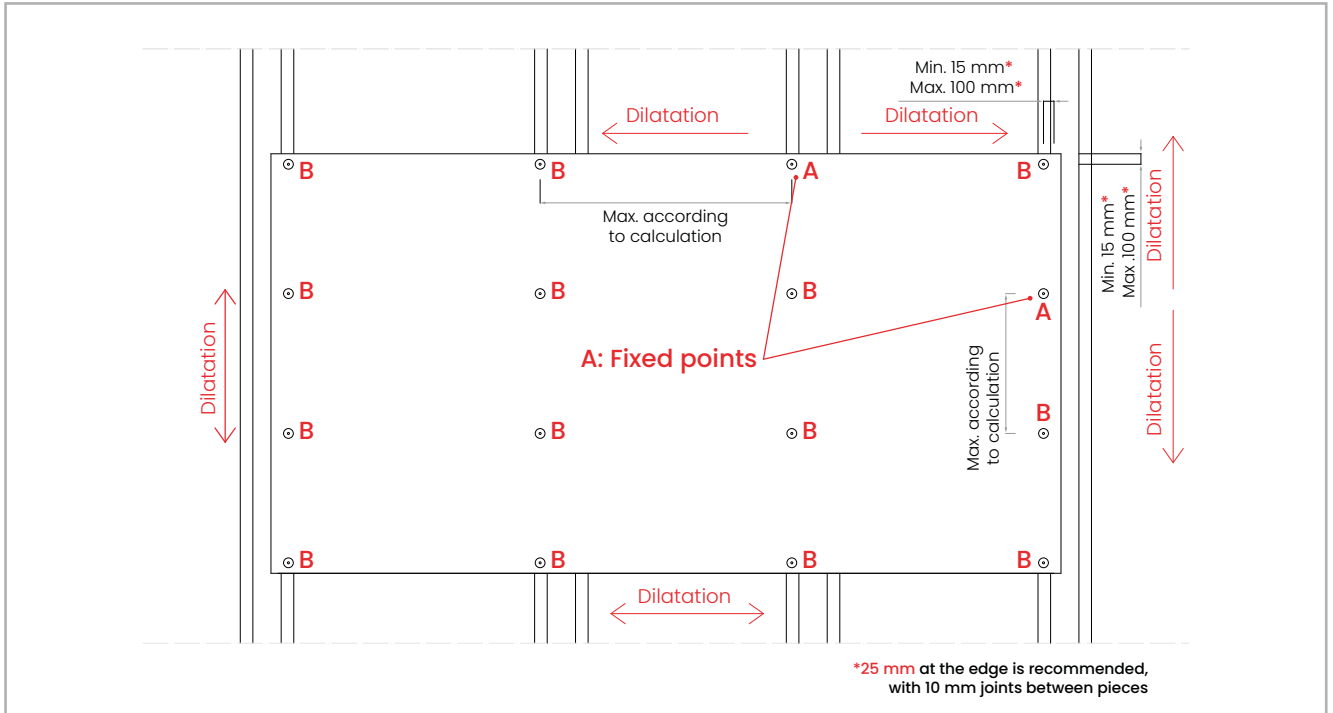

Note: other rivets or similar fasteners may be used provided that their mechanical characteristics are equal to or superior to those specified by **STACBOND**.

FIXED POINTS **A**

SLIDING POINTS **B**

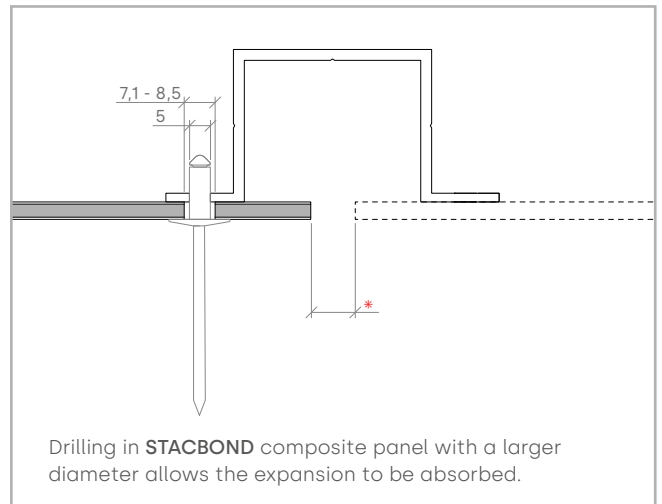
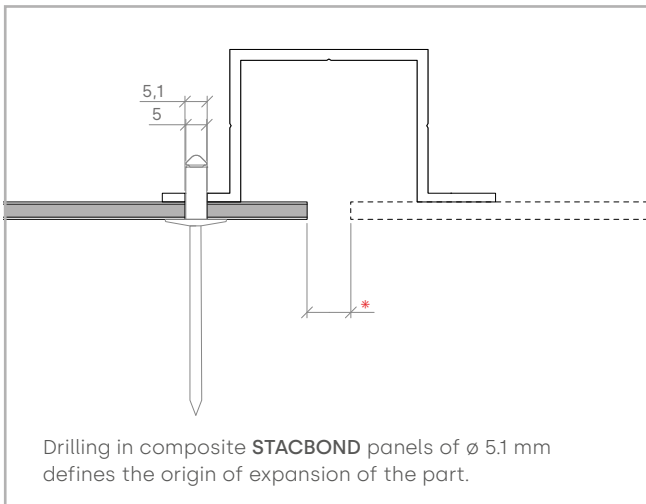

Heights in **mm**

* The size of the expansion joint between panels must be calculated according to the coefficient of thermal expansion according to the technical data sheet, and the dimensions of the pieces.

STB-REM SYSTEM

REFERENCE LIST

INSULATING WEDGES

REF.	COMPONENT
05.19.066	INSULATING WEDGE FOR SPACERS DOUBLE L WITH REF: 05.19.042 / 05.19.045
05.19.068	INSULATING WEDGE FOR SPACERS L WITH REF: 05.19.053 / 05.19.054 / 05.19.055 / 05.19.056 / 05.19.082 / 05.19.083 / 05.19.084 / 05.19.085
05.19.072	INSULATING WEDGE FOR SPACERS L WITH REF: 05.19.041 / 05.19.044 / 05.19.051 / 05.19.052 / 05.19.078 / 05.19.079 / 05.19.080 / 05.19.081
05.19.070	3 x GROOVE WASHERS FOR SPACERS L WITH REF: 05.19.066 / 05.19.068 / 05.19.072

SPACERS

REF.	COMPONENT
05.19.004	SPACER DOUBLE T 57
05.19.005	SPACER DOUBLE T 72
05.19.006	SPACER DOUBLE T 87
05.19.007	SPACER DOUBLE T 102
05.19.030	SPACER DOUBLE T 117
05.19.031	SPACER DOUBLE T 132
05.19.032	SPACER DOUBLE T 147
05.19.033	SPACER DOUBLE T 162
05.19.034	SPACER DOUBLE T 177
05.19.035	SPACER DOUBLE T 192
05.19.036	SPACER DOUBLE T 207
05.19.037	SPACER DOUBLE T 222
05.19.038	SPACER DOUBLE T 237
05.19.039	SPACER DOUBLE T 252
05.19.046	SPACER U 57
05.19.047	SPACER U 72

PROFILES

REF.	COMPONENT
05.19.003	OMEGA PROFILE

ADDITIONAL COMPONENTS

REF.	COMPONENT
05.19.020	STB-REM UPRIGHT CONNECTION

FIXING ACCESSORIES

REF.	COMPONENT
STB-FIJA-201	RIVETER NOSEPIECE FOR SS0-D15 RIVETS INOX/INOX
STB-FIJA-202	RIVETER NOSEPIECE FOR RIVETS ALU/INOX AP14
STB-FIJA-203	DUAL DIAMETER DRILL BIT (HSS-7.0/5.1x74)
STB-FIJA-204	DEPTH LIMITER 16x18
STB-FIJA-205	CENTRING GAUCHE (DG-146x20-7)
STB-FIJA-206	REPLACEMENT NOSEPIECE DEVICE FOR CENTRING GAUGE \varnothing 7 mm
STB-FIJA-207	SPECIAL DRILL BIT FOR CENTRING GAUCHE (HSS-DG-5,1x110)
STB-FIJA-208	DRIVER BIT T20WW-25-HEX1/4"
STB-FIJA-209	MANUAL CENTRING GAUCHE FOR SLA3 SCREW
STB-FIJA-210	SOCKET IRIUS G-00106.07
STB-T0100	SECURITY SCREW 4.8x19 INOX HEAD TORX SLA3/6-S-D12-4.8x19
STB-R0100	ALU/SS RIVET \varnothing 5X12, D.HEAD 14
STB-R0200	FACADE RIVET HEAD 15 mm INOX/INOX A4 5x14 SS0-D15-50140

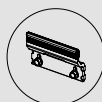

See all available accessories on page 131

STB-REM SYSTEM

TOTAL THICKNESS RATIO, ACCORDING TO SPACERS AND INSULATOR

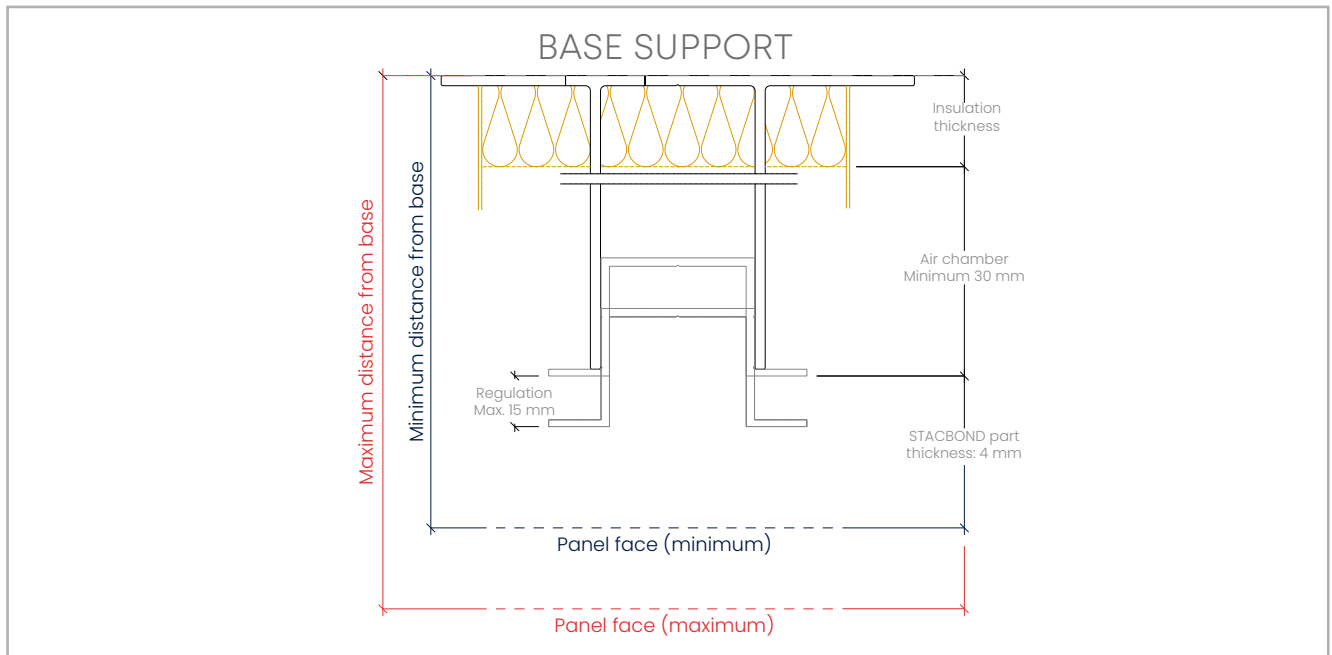

Note: the use of insulating wedges will increase the distance to the outer face of the panel by 5 mm.

SPACER DOUBLE T		DISTANCE (mm) FROM THE BASE OF THE ANCHORING TO EXPOSED PANEL FACE		INSULATING THICKNESS (mm) FOR 15 mm ADJUSTMENT*
REF.	COMPONENT	MINIMUM	MAXIMUM	MAXIMUM
05.19.004	SPACER DOUBLE T 57	63	78	—
05.19.005	SPACER DOUBLE T 72	78	93	40
05.19.006	SPACER DOUBLE T 87	93	108	50
05.19.007	SPACER DOUBLE T 102	108	123	70
05.19.030	SPACER DOUBLE T 117	123	138	80
05.19.031	SPACER DOUBLE T 132	138	153	100
05.19.032	SPACER DOUBLE T 147	153	168	110
05.19.033	SPACER DOUBLE T 162	168	183	130
05.19.034	SPACER DOUBLE T 177	183	198	140
05.19.035	SPACER DOUBLE T 192	198	213	160
05.19.036	SPACER DOUBLE T 207	213	228	170
05.19.037	SPACER DOUBLE T 222	228	243	190
05.19.038	SPACER DOUBLE T 237	243	258	200
05.19.039	SPACER DOUBLE T 252	258	273	220
SPACER U		DISTANCE (mm) FROM THE BASE OF THE ANCHORING TO EXPOSED PANEL FACE		INSULATING THICKNESS (mm) FOR 15 mm ADJUSTMENT*
REF.	COMPONENT	MINIMUM	MAXIMUM	MAXIMUM
05.19.046	SPACER U 57	63	78	—
05.19.047	SPACER U 72	78	93	40

* For the calculation of the maximum admissible thickness, rigid insulation has been taken into account, guaranteeing the maximum regulation of each system and maintaining an air gap of ≥ 30 mm.

STACBOND
more than you see

STB-PEG

GLUED SYSTEM

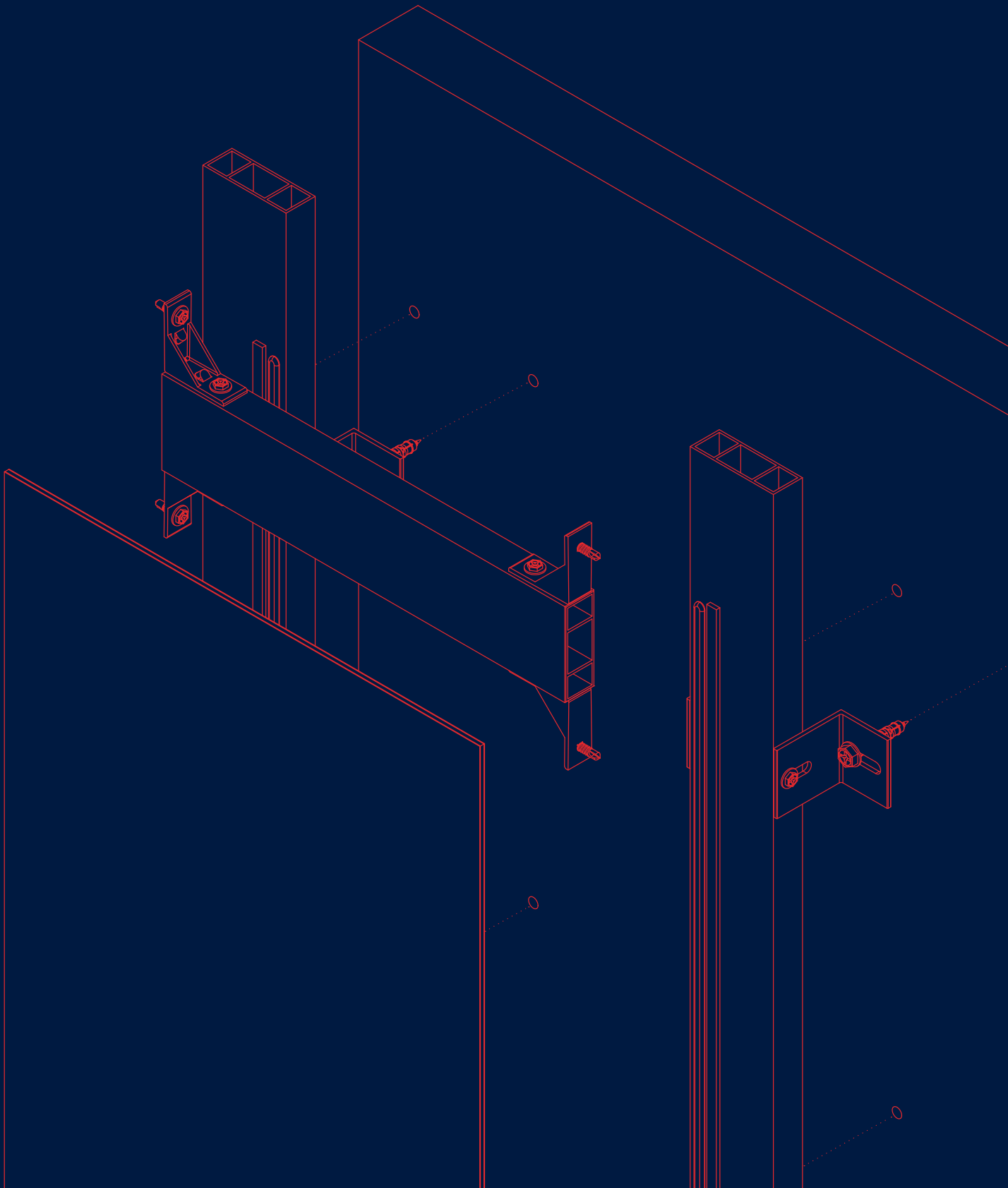

STB-PEG SYSTEM

DESCRIPTION

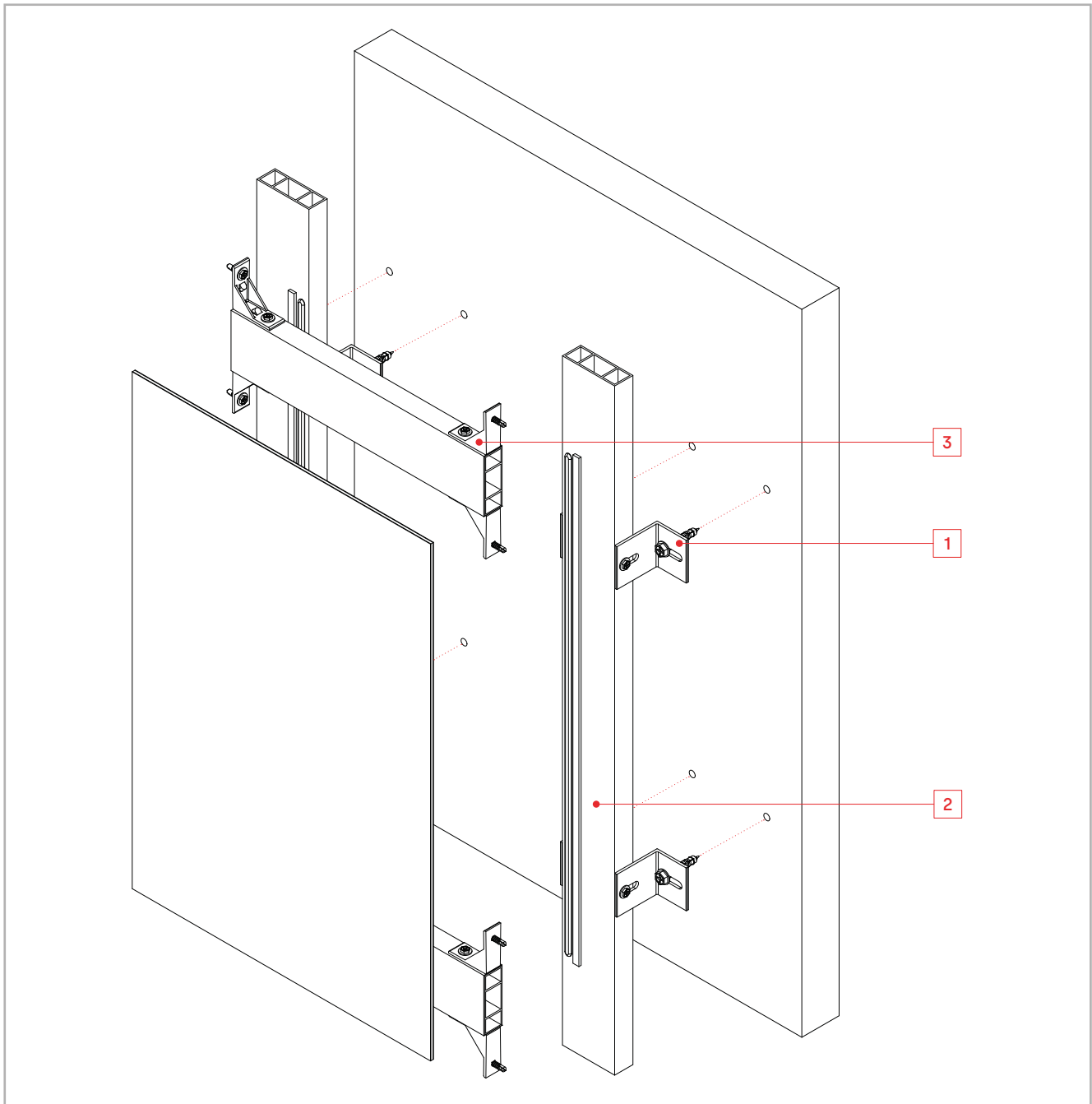

The **STB-PEG** is a kit system of unformed panels from **STACBOND composite panels for the assembly of ventilated façades**. It is a concealed fixing system that is quick to assemble and economical, and can be used for both horizontal and vertical cut-outs.

As a chemically bonded system, it is resistant to ageing and weathering. It also absorbs vibrations and offers multiple possibilities for façade design.

The substructure is made of 70 x 24.5 mm **TUBULAR PROFILES STB-PEG** and **ANGULAR SPACERS** made of 6063 T5/T6 aluminium alloy.

The spacers are anchored to the wall by means of special mechanical fasteners, recommended in each case by fastener suppliers, and receive the **TUBULAR PROFILES STB-PEG** as vertical uprights.

STACBOND composite panel sheets are fixed to the substructure of vertical and/or horizontal T-profiles by means of a specific adhesive and double-sided tape.

SPACER ANGULAR (1)

REF. 19.021

For connecting horizontal T-profiles to the vertical substructure.



TUBULAR PROFILE STB-PEG (2)

REF. 19.022

In vertical joints between cassettes, for fixing STACBOND composite panels.



STUDS JOINING STB-PEG (3)

REF. 05.19024

For attaching tubular profile STB-PEG and system to the support.



ANCHOR AND SCREW

REF. STB-T0800 / STB-T0801

For fixing the spacer to concrete or masonry. The specific load shall be checked by extraction test according to ETAG 020.



SEPARATOR / UPRIGHT FIXING SCREW

REF. STB-T0300 / STB-T0310 / STB-T0311 / STB-T0312

For fixing uprights to angle spacers and connecting tubular profiles STB-PEG to profiles.



STB-PEG SYSTEM

ADDITIONAL COMPONENTS

STUDS JOINING STB-PEG

The tubular profile STB-PEG connecting piece is made of injection-moulded Zamak 5 and enables the construction of bi-directional substructures by means of mechanical fastening between STB-PEG mullion profiles.

It is fixed by means of \varnothing 4.8 mm blind rivet or \varnothing 4.8 mm self-drilling screws. These connection solutions are compatible with the possible expansions of the substructure.

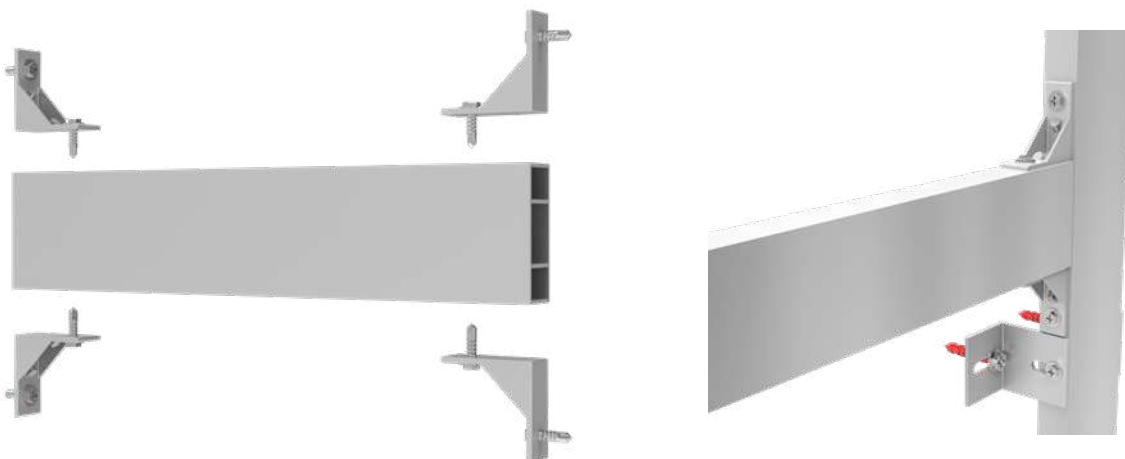

PANEL GLUING

1. Cleaning of the substructure and priming. The substructure must be clean, dry, homogeneous, free of oil, grease, dust and loose or poorly adhering particles. Paints, grouts and other coatings must be removed. The primer shall be applied with a product that reinforces the adhesion of the adhesive putty to the substructure, SIKATAACK PANEL PRIMER (or similar).

2. Application of double-sided adhesive tape. SIKATAACK PANEL -3 double-sided adhesive tape (or similar) is used for the initial fixing of the panels until the adhesive polymerises to achieve a minimum adhesive thickness of 3 mm, which absorbs possible expansion and vibrations produced in the STACBOND composite panel façade. Long-term resistance is achieved only with the adhesive.

3. Elastic adhesive. Apply a continuous vertical bead of SIKATAACK PANEL 50 (or similar) elastic adhesive using its triangular nozzle (8 mm wide, 10 mm long) at least 5 mm away from the tape. For correct application, the application gun must be positioned perpendicular to the surface.

4. Placement of the panel. Remove the protective film from the double-sided adhesive tape. Carefully position the panel in its precise place and press firmly until the panel comes into contact with the double-sided tape.

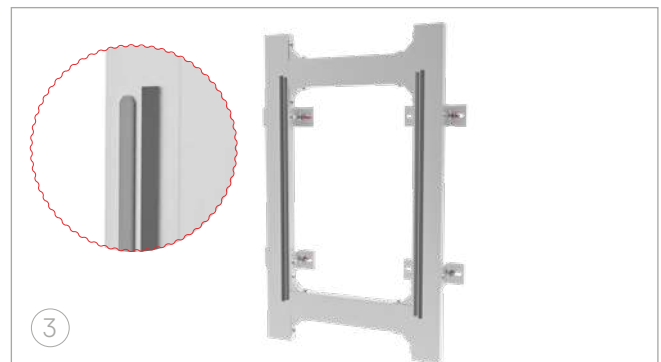

STB-PEG SYSTEM

REFERENCE LIST

SPACERS

REF.	COMPONENT
19.021	SPACER ANGULAR

PROFILES

REF.	COMPONENT
19.022	TUBULAR PROFILE STB-PEG

ADDITIONAL COMPONENTS

REF.	COMPONENT
05.19.024	STB-PEG UPRIGHT CONNECTION



See all available accessories on page 131

FIXING ACCESSORIES

REF.	COMPONENT
STB-T0800	ANCHOR + SCREW SET FOR FIXING BRACKET TO WALL X3 10X80 HEX. 3DG WIDE NECK
STB-T0801	ANCHOR + SCREW SET FOR FIXING BRACKET TO WALL SDF-KB-10X80-E A4 STAINLESS STEEL WIDE NECK
STB-T0300	SELF-TAPPING SCREW SDA5/3.5-6-H13-SA-5.5X20
STB-T0310	SLIDING POINT BRACKET-PROFILE FIXING SCREW JT9-2/5-5.0x25 VARIO STAINLESS STEEL A4
STB-T0311	DRILL BIT JT4-3H/5-5.5x19 INOX-A2 - FIXED POINT
STB-T0312	DRILL BIT JT9-3H/5-5.5x19 INOX-A4 - FIXED POINT

ACCESSORIES

FOR ASSEMBLY SYSTEMS

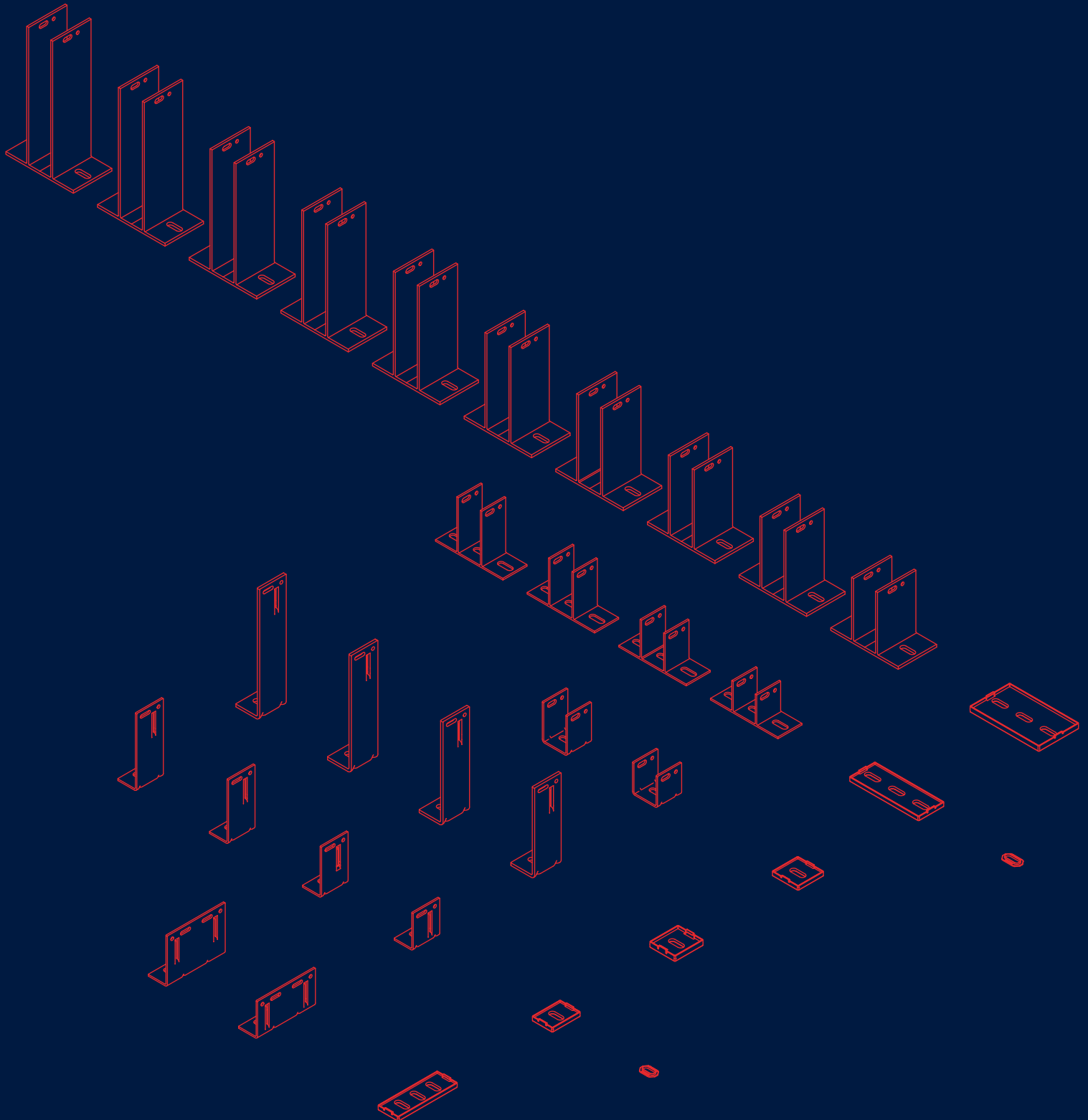

USES OF THE DIFFERENT **STACBOND** PROFILES

GUIDE TO THE DIFFERENT SYSTEMS

REF.	DESCRIPTION	ASSEMBLY SYSTEMS											
		STB-T-CH			STB-T-SZ			T-REM	T-PEG	CH	SZ	REM	PEG
		Standard	evo®	PRO®	Standard	evo®	PRO®						
	05.19.043 PROFILE T 2 mm				✓	✓	✓	✓	✓				
	05.19.061 PROFILE T-OMEGA	✓	✓			✓	✓						
	05.19.059 PROFILE L INTERMEDIATE		✓		✓	✓	✓	✓	✓				
	05.19.092 STB-T-CH-PRO® PROFILE			✓									
	05.19.093 STB-T-CH-PRO® SHORT PROFILE Use with spacers 05.19.089 and 05.19.090			✓									
	05.19.120 STB-T-CH-PRO® INTERMEDIATE L PROFILE			✓									
	05.19.107 STIFFENING PROFILE		✓	✓		✓	✓			✓	✓		
	05.19.099 STARTER PROFILE				✓	✓	✓				✓		
	05.19.121 S PROFILE				✓	✓					✓		
	05.19.122 Z PROFILE				✓	✓					✓		
	05.19.049 REINFORCEMENT PROFILE STB-T-SZ				✓								
	05.19.003 OMEGA PROFILE 2 mm									✓	✓	✓	
	05.99.231 REINFORCEMENT STB-SZ										✓		
	19.022 TUBULAR PROFILE STB-PEG* Minimum order: 585 m (90 profiles)												✓

* References on request. Consult manufacturing and distribution deadlines.

STACBOND ACCESSORIES

PROFILES



REFERENCE	COMPONENT	LENGTH (mm)	ALLOY	UNITS/BOX
05.19.003	OMEGA PROFILE (2 mm)	6500	6063 T5/T6	12



REFERENCE	COMPONENT	LENGTH (mm)	ALLOY	UNITS/BOX
05.19.040	OMEGA PROFILE (2.5 mm)	6500	6063 T5/T6	12 *



REFERENCE	COMPONENT	LENGTH (mm)	ALLOY	UNITS/BOX
05.19.043	PROFILE T	6500	6063 T5/T6	11 *



REFERENCE	COMPONENT	LENGTH (mm)	ALLOY	UNITS/BOX
19.022	TUBULAR PROFILE STB-PEG	6500	6063 T5/T6	10 *



REFERENCE	COMPONENT	LENGTH (mm)	ALLOY	UNITS/BOX
05.19.059	PROFILE L INTERMEDIATE	6500	6063 T5/T6	21



REFERENCE	COMPONENT	LENGTH (mm)	ALLOY	UNITS/BOX
05.19.120	STB-T-CH-PRO® INTERMEDIATE L PROFILE	6500	6063 T5/T6	—



REFERENCE	COMPONENT	LENGTH (mm)	ALLOY	UNITS/BOX
05.19.061	PROFILE T-OMEGA	6500	6063 T5/T6	8

STACBOND ACCESSORIES

PROFILES



REFERENCE	COMPONENT	LENGTH (mm)	ALLOY	UNITS/BOX
05.19.092	STB-T-CH-PRO® PROFILE	6500	6063 T5/T6	—



REFERENCE	COMPONENT	LENGTH (mm)	ALLOY	UNITS/BOX
05.19.093	STB-T-CH-PRO® SHORT PROFILE	6500	6063 T5/T6	—

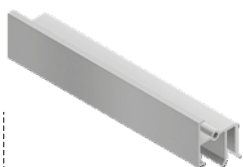

REFERENCE	COMPONENT	LENGTH (mm)	ALLOY	UNITS/BOX
05.19.107	STIFFENING PROFILE	6500	6063 T5/T6	—

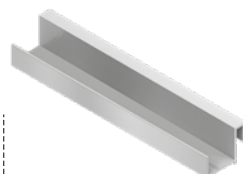

REFERENCE	COMPONENT	LENGTH (mm)	ALLOY	UNITS/BOX
05.19.121	S PROFILE	6500	6063 T5/T6	18

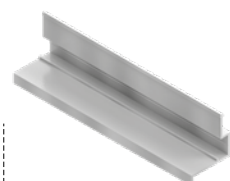

REFERENCE	COMPONENT	LENGTH (mm)	ALLOY	UNITS/BOX
05.19.122	Z PROFILE	6500	6063 T5/T6	18



REFERENCE	COMPONENT	LENGTH (mm)	ALLOY	UNITS/BOX
05.19.075	REINFORCEMENT PROFILE STB-SZ	6500	6063 T5/T6	— *



REFERENCE	COMPONENT	LENGTH (mm)	ALLOY	UNITS/BOX
05.19.076	REINFORCEMENT PROFILE STB-T-SZ	6500	6063 T5/T6	50 *

Note: the profiles are supplied with a length of 6500 mm. For other formats, please contact STACBOND.

* References on request. Consult manufacturing and distribution deadlines.

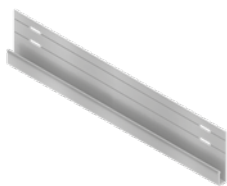

REFERENCE	COMPONENT	LENGTH (mm)	ALLOY	UNIT/BOX
05.19.099	STARTER PROFILE	6500	6063 T5/T6	—

SPACERS



REFERENCE	COMPONENT	ALLOY	UNIT/BOX
05.19.004	SPACER DOUBLE T 57	6063 T5	96
05.19.005	SPACER DOUBLE T 72	6063 T5	80
05.19.006	SPACER DOUBLE T 87	6063 T5	80
05.19.007	SPACER DOUBLE T 102	6063 T5	72



REFERENCE	COMPONENT	ALLOY	UNIT/BOX
05.19.030	SPACER DOUBLE T 117	6005 T6	50
05.19.031	SPACER DOUBLE T 132	6005 T6	24
05.19.032	SPACER DOUBLE T 147	6005 T6	40
05.19.033	SPACER DOUBLE T 162	6005 T6	40
05.19.034	SPACER DOUBLE T 177	6005 T6	36
05.19.035	SPACER DOUBLE T 192	6005 T6	24
05.19.036	SPACER DOUBLE T 207	6005 T6	24
05.19.037	SPACER DOUBLE T 222	6005 T6	24
05.19.038	SPACER DOUBLE T 237	6005 T6	24
05.19.039	SPACER DOUBLE T 252	6005 T6	24

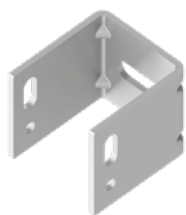

REFERENCE	COMPONENT	ALLOY	UNIT/BOX
05.19.046	SPACER U 57	5005 H24	125
05.19.047	SPACER U 72	5005 H24	100



REFERENCE	COMPONENT	ALLOY	UNIT/BOX
19.021	SPACER ANGULAR	6063 T5	100

STACBOND ACCESSORIES

SPACERS

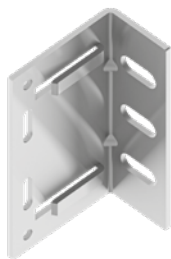

REFERENCE	COMPONENT	ALLOY	UNIT/BOX
05.19.042	SPACER DOUBLE L 68	5005 H24	250
05.19.045	SPACER DOUBLE L 92	5005 H24	180

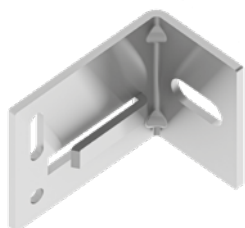

REFERENCE	COMPONENT	ALLOY	UNIT/BOX
05.19.089	SPACER L 41	5005 H24	400
05.19.090	SPACER L 51	5005 H24	350
05.19.041	SPACER L 68	5005 H24	528
05.19.044	SPACER L 92	5005 H24	200
05.19.051	SPACER L 116	5005 H24	180
05.19.052	SPACER L 140	5005 H24	276
05.19.053	SPACER L 164	5005 H24	176
05.19.054	SPACER L 188	5005 H24	135
05.19.055	SPACER L 212	5005 H24	120
05.19.056	SPACER L 236	5005 H24	56

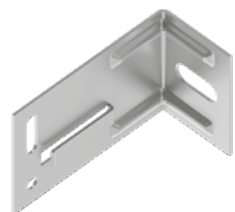

REFERENCE	COMPONENT	ALLOY	UNIT/BOX
05.19.078	SPACER INOX L 61	AISI 304	—
05.19.112	SPACER INOX L 61	AISI 430	—
05.19.079	SPACER INOX L 85	AISI 304	—
05.19.113	SPACER INOX L 85	AISI 430	—
05.19.080	SPACER INOX L 109	AISI 304	—
05.19.114	SPACER INOX L 109	AISI 430	—
05.19.081	SPACER INOX L 133	AISI 304	—
05.19.115	SPACER INOX L 133	AISI 430	—
05.19.082	SPACER INOX L 157	AISI 304	—
05.19.116	SPACER INOX L 157	AISI 430	—
05.19.083	SPACER INOX L 181	AISI 304	—
05.19.117	SPACER INOX L 181	AISI 430	—
05.19.084	SPACER INOX L 205	AISI 304	—
05.19.118	SPACER INOX L 205	AISI 430	—
05.19.085	SPACER INOX L 229	AISI 304	—
05.19.119	SPACER INOX L 229	AISI 430	—

STACBOND ACCESSORIES

AUXILIARY ELEMENTS



REFERENCE	COMPONENT	ALLOY	UNIT/BOX
05.99.231	REINFORCEMENT STB-SZ	6063 T5	174



REFERENCE	COMPONENT	ALLOY	UNIT/BOX
05.19.049	REINFORCEMENT STB-T-SZ	6063 T5	180

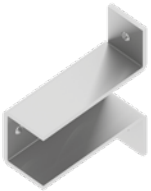

REFERENCE	COMPONENT	ALLOY	UNIT/BOX
05.19.020	STB-REM UPRIGHT CONNECTION	5005 H24	150



REFERENCE	COMPONENT	ALLOY	UNIT/BOX
05.19.024	STB-PEG UPRIGHT CONNECTION	Zamak 5	100



REFERENCE	COMPONENT	ALLOY	UNIT/BOX
19.019	REINFORCEMENT PLATE FOR HANGER	1050 H24	500



REFERENCE	COMPONENT	ALLOY	UNIT/BOX
05.19.050	CASSETTE FORMING PLATE	1050 H24	1.000

STACBOND ACCESSORIES

AUXILIARY ELEMENTS

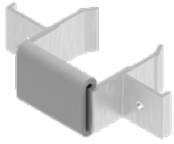

REFERENCE	COMPONENT	ALLOY	UNIT/BOX
A05.19.013	BRACKET SET STB-CH HANGING (GREY)	6063 T5	50

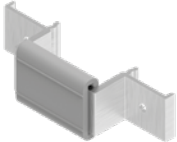

REFERENCE	COMPONENT	ALLOY	UNIT/BOX
A05.19.062	BRACKET SET STB-T-CH HANGING (GREY)	6063 T5	50

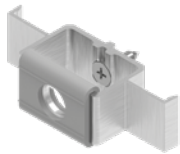

REFERENCE	COMPONENT	UNIT/BOX
05.19.088	STB-T-CH-PRO® HANGING BRACKET SET	50



REFERENCE	COMPONENT	UNIT/BOX
05.19.087	STB-T-CH-PRO® HANGING BRACKET GASKET	200



REFERENCE	COMPONENT	ALLOY	UNIT/BOX
05.19.025	STIFFENER SCH-1 (< 750 mm)	—	—
05.19.026	STIFFENER SCH-2 (750 - 1.500 mm)	—	—
05.19.027	STIFFENER SCH-3 (1.500 - 2.400 mm)	—	—
05.19.027.1	STIFFENER SCH-4 (2.400 - 4.000 mm)	—	—
05.19.027.2	STIFFENER SCH-5 (4.000 - 5.000 mm)	—	—
05.19.027.3	STIFFENER SCH-6 (> 5.000 mm)	—	—

STACBOND ACCESSORIES

AUXILIARY ELEMENTS



REFERENCE	COMPONENT	UNIT/BOX
05.19.106	CH HORIZONTAL STIFFENER LONG BRACKET	160



REFERENCE	COMPONENT	UNIT/BOX
05.19.105	CH HORIZONTAL STIFFENER SHORT BRACKET	200



REFERENCE	COMPONENT	UNIT/BOX
05.19.109	CH HORIZONTAL STIFFENER MINI BRACKET	50



REFERENCE	COMPONENT	UNIT/BOX
05.19.108	CH CASSETTE LOWER CLIP	200



REFERENCE	COMPONENT	UNIT/BOX
05.19.094	STB-T-SZ-PRO® SHORT Z BRACKET	200

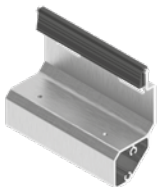

REFERENCE	COMPONENT	UNIT/BOX
05.19.095	STB-T-SZ-PRO® LONG Z BRACKET	80

STACBOND ACCESSORIES

AUXILIARY ELEMENTS

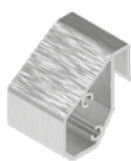

REFERENCE	COMPONENT	UNIT/BOX
05.19.096	STB-T-SZ-PRO® SHORT S BRACKET	200

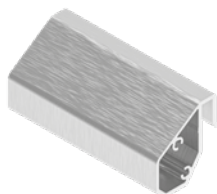

REFERENCE	COMPONENT	UNIT/BOX
05.19.097	STB-T-SZ-PRO® LONG S BRACKET	80



REFERENCE	COMPONENT	UNIT/BOX
05.19.101	SZ HORIZONTAL STIFFENER LONG BRACKET	160

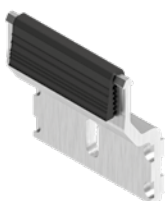

REFERENCE	COMPONENT	UNIT/BOX
05.19.100	SZ HORIZONTAL STIFFENER SHORT BRACKET	200



REFERENCE	COMPONENT	UNIT/BOX
05.19.110	SZ HORIZONTAL STIFFENER MINI BRACKET	50



REFERENCE	COMPONENT	UNIT/BOX
05.19.129	PIECE OF GASKET JOINT FOR LONG PROFILES (41 MM)	200

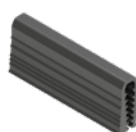

REFERENCE	COMPONENT	UNIT/BOX
05.19.123	PIECE OF GASKET JOINT (to replace the gasket in the Z-square part ref. 05.19.094)	200

STACBOND ACCESSORIES

FASTENING ACCESSORIES

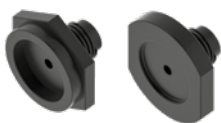

REFERENCE	COMPONENT	OBSERVATIONS	MIN. UNITS
STB-FIJA-201	RIVETER NOSEPIECE (RIVETS SSO-D15)	Limits cinch strength for mobile anchoring points	1
STB-FIJA-202	RIVETER NOSEPIECE FOR RIVETS ALU/INOX AP14	Limits cinch strength for mobile anchoring points	1



REFERENCE	COMPONENT	OBSERVATIONS	MIN. UNITS
STB-FIJA-203	DUAL DIAMETER DRILL BIT (HSS-7.0/5.1x74)	Drills panel to 7 mm and the substructure to 5,1 mm	1



REFERENCE	COMPONENT	OBSERVATIONS	MIN. UNITS
STB-FIJA-204	DEPTH LIMITER 16x18	Works with the dual diameter bit to stop the 7 mm shank drilling into the substructure	1

REFERENCE	COMPONENT	OBSERVATIONS	MIN. UNITS
STB-FIJA-205	CENTRING GAUGE (DG-146x20-7)	To make the 5,1 mm hole in the substructure through the 7 mm hole in the panel	1
STB-FIJA-206	REPLACEMENT NOSEPIECE DEVICE FOR CENTRING GAUGE ø 7 mm	Replacement nose piece in the event of damage.	1
STB-FIJA-206.8	REPLACEMENT NOSEPIECE FOR CENTRING GAUGE ø 8 mm	Replacement nose piece in the event of damage.	1
STB-FIJA-207	SPECIAL DRILL BIT FOR CENTRING GAUCHE (HSS-DG-5,1x110)	Special drill bit for the gauge with shorter helical shaft .	1



REFERENCE	COMPONENT	MIN. UNITS	UNIT/BOX
STB-FIJA-208	DRIVER BIT T20WW-25-HEX1/4"	1	1



REFERENCE	COMPONENT	MIN. UNITS	UNIT/BOX
STB-FIJA-213	TIP FOR FLAT HEAD SCREW REF: STB-T0700	1	1



REFERENCE	COMPONENT	MIN. UNITS	UNIT/BOX
STB-FIJA-209	MANUAL CENTRING GAUCHE FOR SLA3 SCREW	1	1

STACBOND ACCESSORIES

FASTENING ACCESSORIES



REFERENCE	COMPONENT	FINISH	MIN. UNITS	UNIT/BOX
STB-T0100	SECURITY SCREW 4.8x19 INOX HEAD TORX SLA3/6- S-D12-4.8x19	UNPAINTED	500	500
		PAINTED — RAL	1.000	500



REFERENCE	COMPONENT	FINISH	MIN. UNITS	UNIT/BOX
STB-T0300	SELF-TAPPING SCREW SDA5/3.5-6-H13-SA- 5.5X20	UNPAINTED	500	500
		PAINTED — RAL	500	500



REFERENCE	COMPONENT	FINISH	MIN. UNITS	UNIT/BOX
STB-T0310	SLIDING POINT BRACKET- PROFILE FIXING SCREW JT9-2/5-5.0x25 VARIO STAINLESS STEEL A4	UNPAINTED	500	500
		PAINTED — RAL	500	500



REFERENCE	COMPONENT	FINISH	MIN. UNITS	UNIT/BOX
STB-T0311	DRILL BIT JT4-3H/5-5.5x19 INOX-A2 - FIXED POINT	UNPAINTED	500	500
		PAINTED — RAL	500	500
STB-T0312	DRILL BIT JT4-3H/5-5.5x19 INOX-A4 - FIXED POINT	UNPAINTED	500	500
		PAINTED — RAL	500	500



REFERENCE	COMPONENT	FINISH	MIN. UNITS	UNIT/BOX
STB-T0600	SELF-DRILLING SCREW 4.2x19 STAINLESS STEEL A2 DIN 7504-N ROUNDED CYLINDRICAL HEAD	UNPAINTED	1.000	1.000
		PAINTED — RAL	1.000	1.000



REFERENCE	COMPONENT	FINISH	MIN. UNITS	UNIT/BOX
STB-T0610	SELF-DRILLING SCREW 4.2x19 STAINLESS STEEL A2 DIN 7504-K HEXAGONAL HEAD	UNPAINTED	1.000	1.000
		PAINTED — RAL	1.000	1.000

STACBOND ACCESSORIES

FASTENING ACCESSORIES



REFERENCE	COMPONENT	UNIT/BOX
STB-3M-160GF25	3M DOUBLE-SIDED TAPE VHB-GPH, THICKNESS 1,6 MM, WIDTH 25 MM	Rolls of 33 ml



REFERENCE	COMPONENT	FINISH	MIN. UNITS	UNIT/BOX
STB-T0700	FLAT HEAD SCREW - 4,2x20	UNPAINTED	1.000	1.000
		PAINTED – RAL	1.000	1.000



REFERENCE	COMPONENT	FINISH	MIN. UNITS	UNIT/BOX
STB-T0800	ANCHOR + SCREW SET FOR FIXING BRACKET TO WALL X3 10X80 HEX. 3DG WIDE NECK	UNPAINTED	50	50
		PAINTED – RAL	50	50



REFERENCE	COMPONENT	FINISH	MIN. UNITS	UNIT/BOX
STB-T0801	ANCHOR + SCREW SET FOR FIXING BRACKET TO WALL SDF-KB-10X80-E A4 STAINLESS STEEL WIDE NECK	UNPAINTED	100	100
		PAINTED – RAL	100	100



REFERENCE	COMPONENT	FINISH	MIN. UNITS	UNIT/BOX
STB-R0100	ALU/SS RIVET Ø5X12, D.HEAD 14	UNPAINTED	500	500
		PAINTED – RAL	1.000	500
STB-R0200	FACADE RIVET HEAD 15 mm INOX/INOX A4 5x14 SS0-D15-50140	UNPAINTED	500	500
		PAINTED – RAL	1.000	500

APPLICATION: to attach **STACBOND** panels to STB-REM / STB-T-REM substructures for environments with high chloride exposure



REFERENCE	COMPONENT	FINISH	MIN. UNITS	UNIT/BOX
STB-R0300	ALU/SS RIVET Ø4.8X12, D.HEAD 9.5	UNPAINTED	500	500
		PAINTED – RAL	1.000	500

APPLICATION: to form CH and SZ cassettes from **STACBOND** composite panels.

STACBOND ACCESSORIES

INSULATING WEDGES FOR SPACERS DOUBLE T / U



REFERENCE	COMPONENT	UNIT/BOX
05.19.071	3 x GROOVE WASHERS FOR SPACERS L WITH REF.: 05.19.067 / 05.19.069 / 05.19.073	1.000



REFERENCE	COMPONENT	UNIT/BOX
05.19.067	INSULATING WEDGE FOR SPACERS U WITH REF.: 05.19.046 / 05.19.047	350



REFERENCE	COMPONENT	UNIT/BOX
05.19.069	INSULATING WEDGE FOR SPACERS DOUBLE T WITH REF.: 05.19.030 / 05.19.031 / 05.19.032 / 05.19.033 / 05.19.034 / 05.19.035 / 05.19.036 / 05.19.037 / 05.19.038 / 05.19.039	100



REFERENCE	COMPONENT	UNIT/BOX
05.19.073	INSULATING WEDGE FOR SPACERS DOUBLE T WITH REF.: 05.19.004 / 05.19.005 / 05.19.006 / 05.19.007	140



STACBOND ACCESSORIES

INSULATING WEDGES FOR SPACERS L



REFERENCE	COMPONENT	UNIT/BOX
05.19.070	3 x GROOVE WASHERS WITH REF: 05.19.066 / 05.19.068 / 05.19.072	1.000



REFERENCE	COMPONENT	UNIT/BOX
05.19.066	INSULATING WEDGE FOR SPACERS DOUBLE L WITH REF: 05.19.042 / 05.19.045	250



REFERENCE	COMPONENT	UNIT/BOX
05.19.068	INSULATING WEDGE FOR SPACERS L WITH REF: 05.19.053 / 05.19.054 / 05.19.055 / 05.19.056	300
05.19.068	INSULATING WEDGE FOR INOX SPACERS L WITH REF: 05.19.082 / 05.19.083 / 05.19.084 / 05.19.085	300



REFERENCE	COMPONENT	UNIT/BOX
05.19.072	INSULATING WEDGE FOR SPACERS WITH REF: 05.19.041 / 05.19.044 / 05.19.051 / 05.19.052	500
05.19.072	INSULATING WEDGE FOR INOX SPACERS WITH REF: 05.19.078 / 05.19.079 / 05.19.080 / 05.19.081	500



STACBOND
more than you see

PROCESSING

TOOLS

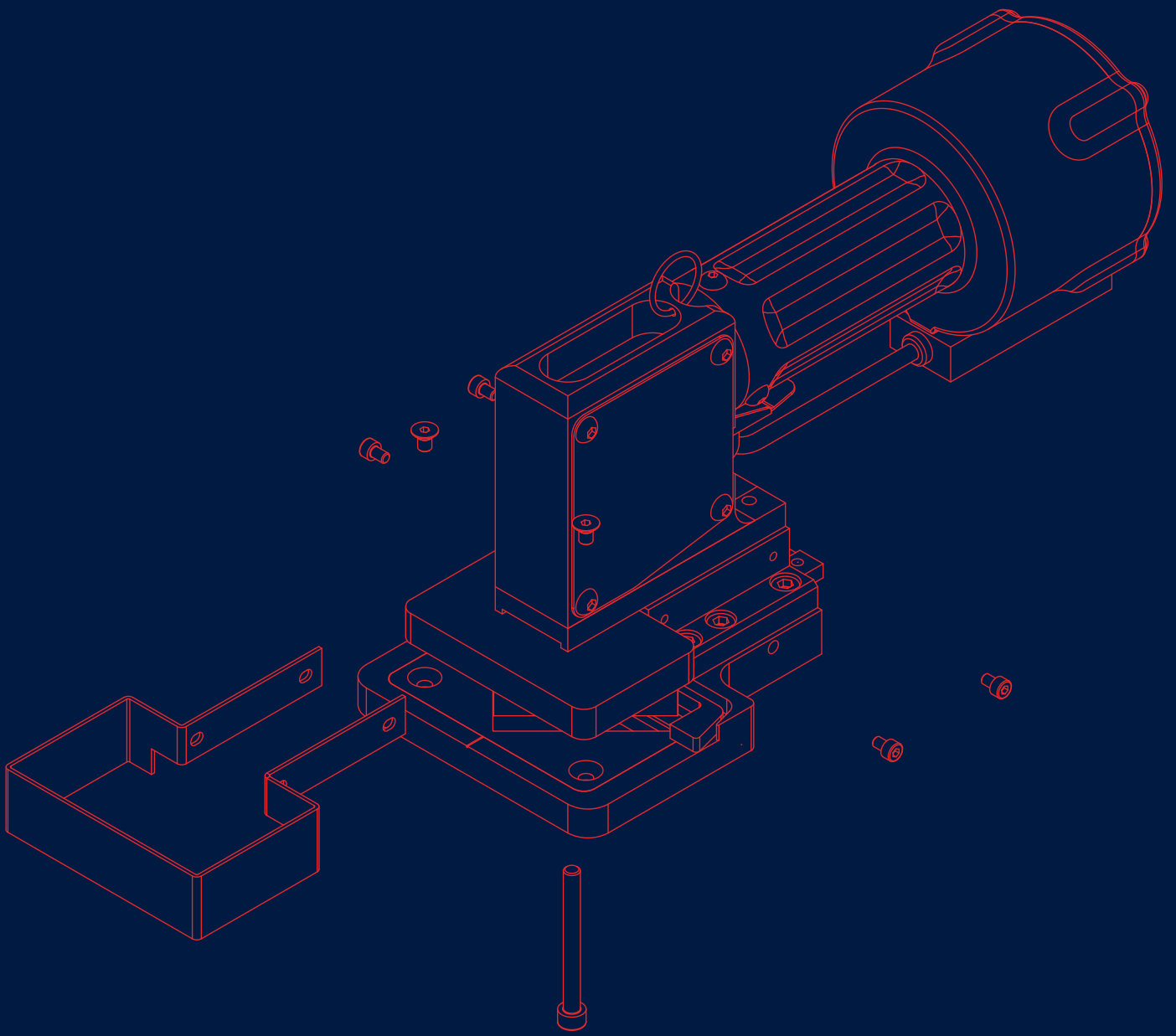

STACBOND PROCESSING TOOLS

MANUAL DIE-CUTTING MACHINE



HANGING BOOT TOOLING DETAIL

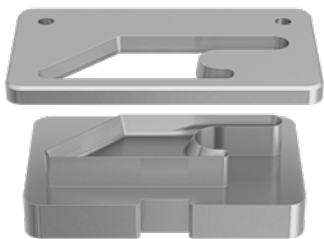

V TOOLING DETAIL

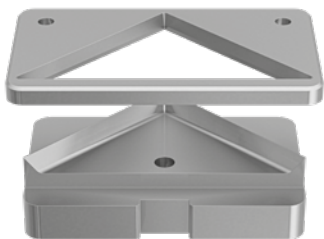

STACBOND DIE-CUTTING MACHINE MANUAL

Easy-to-use and very versatile hand tool for use in the workshop as well as for mobile use in the assembly of facades, trade fairs, etc.

This machine is the ideal complement to work together with a manual milling machine or a wall saw.

Its interchangeable tools, specifically developed for the CH and SZ cassette formats of the **STACBOND** assembly systems, enable the hanging boots and corners to be die-cut for correct shaping.

REFERENCE	COMPONENT	OBSERVATIONS	MIN. UNITS
STB-MC-0010	STACBOND ANUAL DIE-CUTTING MACHINE WITH HANGING BOOT DIE-CUTTING TOOLING	Pre-assembled hanging boot tool allows adjustment for 40 and 45 mm flaps.	1
STB-MC-0011	STACBOND MANUAL DIE-CUTTING MACHINE WITH HANGING BOOT DIE-CUTTING AND V DIE-CUTTING TOOLING	The pre-assembled V-shaped tooling is used to make the cassette forming corners.	1
STB-MC-0012	STACBOND MANUAL DIE-CUTTING MACHINE WITH HANGING BOOT DIE-CUTTING AND V DIE-CUTTING TOOLING	Available interchangeable tools (follow the instructions for use).	1



STACBOND PROCESSING TOOLS

MILLING CUTTERS FOR CNC MACHINES



REFERENCE	COMPONENT	OBSERVATIONS	MIN. UNITS
STB-FMD4X80X3.8	HM HSS MILLING CUTTER ø4,80,5x3,8 Z=2 ø12 BODY 4 mm PANEL CUTTING	ø 4 mm hard metal milling cutter for panel cutting with 4 mm thickness (marking)	1
STB-FM-D5X80X2.8	HM HSS MILLING CUTTER ø5x80x2,8 Z=2 ø12 BODY 3 mm PANEL CUTTING	ø 5 mm hard metal milling cutter for panel cutting with 3 mm thickness (dilation)	1
STB-FMD5X80X3.8	HM HSS MILLING CUTTER ø5x80x3,8 Z=2 ø12 BODY 4 mm PANEL CUTTING	ø 5 mm hard metal milling cutter for panel cutting with 4mm thickness (dilation)	1
STB-FM-D6X80X2.8	HM HSS MILLING CUTTER ø6x80x2,8 Z=2 ø12 BODY 3 mm PANEL CUTTING	ø 6 mm hard metal milling cutter for panel cutting with 3 mm thickness (dilation)	1
STB-FMD6X80X3.8	HM HSS MILLING CUTTER ø6x80x3,8 Z=2 ø12 BODY 4 mm PANEL CUTTING	ø 6 mm hard metal milling cutter for panel cutting with 4 mm thickness (dilation)	1
STB-FMD6X80X5.8	HM HSS MILLING CUTTER ø6x80x3,8 Z=2 ø12 BODY 4 mm PANEL CUTTING	ø 6 mm hard metal milling cutter for panel cutting with 6 mm thickness (dilation)	1



REFERENCE	COMPONENT	OBSERVATIONS	MIN. UNITS
STB-FD5X80X2.8	DIAMOND HSS MILLING CUTTER SPECIAL H4 PCD ø5x80x2,8 Z=2 ø12 HM BODY	ø 6 mm diamond milling cutter for panel cutting with 3 mm thickness	1
STB-FD5X80X3.8	DIAMOND HSS MILLING CUTTER SPECIAL H4 PCD ø5x80x3,8 Z=2 ø12 HM BODY	ø 6 mm diamond milling cutter for panel cutting with 4 mm thickness	1
STB-FD5X80X5.8	DIAMOND HSS MILLING CUTTER SPECIAL H4 PCD ø6x80x5,8 Z=2 ø12 HM BODY	ø 6 mm diamond milling cutter for panel cutting with 6 mm thickness	1
STB-FD6X80X2.8	DIAMOND HSS MILLING CUTTER SPECIAL H4 PCD ø6x80x2,8 Z=2 ø12 HM BODY	ø 6 mm diamond milling cutter for panel cutting with 3 mm thickness	1
STB-FD6X80X3.8	DIAMOND HSS MILLING CUTTER SPECIAL H4 PCD ø6x80x3,8 Z=2 ø12 HM BODY	ø 6 mm diamond milling cutter for panel cutting with 4 mm thickness	1
STB-FD6X80X5.8	DIAMOND HSS MILLING CUTTER SPECIAL H4 PCD ø6x80x5,8 Z=2 ø12 HM BODY	ø 6 mm diamond milling cutter for panel cutting with 6 mm thickness	1



REFERENCE	COMPONENT	OBSERVATIONS	MIN. UNITS
STB-FRESAD6PCD	DIAMOND HSS MILLING CUTTER SECO PCD ø6x75x3,8 ø12 HM BODY	ø 6 mm diamond milling cutter for panel cutting with 4 mm thickness with A2 core	1



REFERENCE	COMPONENT	OBSERVATIONS	MIN. UNITS
STB-FMD-C45	HM HSS MILLING CUTTER ø3x81 90° SPECIAL REF. 1 Z=2 ø12 BODY	Hard metal milling cutter for 45° cutting	1

STACBOND PROCESSING TOOLS

MILLING CUTTERS FOR CNC MACHINES



REFERENCE	COMPONENT	OBSERVATIONS	MIN. UNITS
STB-FRESA90	HSS MD MILLING CUTTER $\phi 3 \times 81$ SPECIAL REF. 1 Z=2 BODY $\phi 16$	Hard metal milling cutter for 90° cutting	1



REFERENCE	COMPONENT	OBSERVATIONS	MIN. UNITS
STB-FEMD-10x72	HM HSS SPHERICAL MILLING CUTTER WITH DIAMOND COA- TING $\phi 10 \times 72$ Z=2 $\phi 10$ BODY (COD:JS532100D1B.0Z2-NXT)	$\phi 10$ mm milling cutter with diamond coating for spherical grooving of panel with PE/FR core	1



REFERENCE	COMPONENT	OBSERVATIONS	MIN. UNITS
STB-FRESAD10P- CD	DIAMOND HSS SPHERICAL MILLING CUTTER SECO PCD $\phi 10 \times 73$ $\phi 10$ HM BODY	$\phi 10$ mm diamond milling cutter for spherical grooving of panel with A2 core	1



REFERENCE	COMPONENT	OBSERVATIONS	MIN. UNITS
STB-FRESA135	HM HSS MILLING CUTTER $\phi 3 \times \phi 32 \times 80 \times 38,8$ R0.2 Z=2 $\phi 16$ BODY	Hard metal milling cutter for 45° cutting	1



REFERENCE	COMPONENT	OBSERVATIONS	MIN. UNITS
STB-FPCD-135	DIAMOND HSS MILLING CUTTER $\phi 35 \times 175$ Z=2 $\phi 16$ BODY	Diamond milling cutter for 135° of panel with A2 core	1

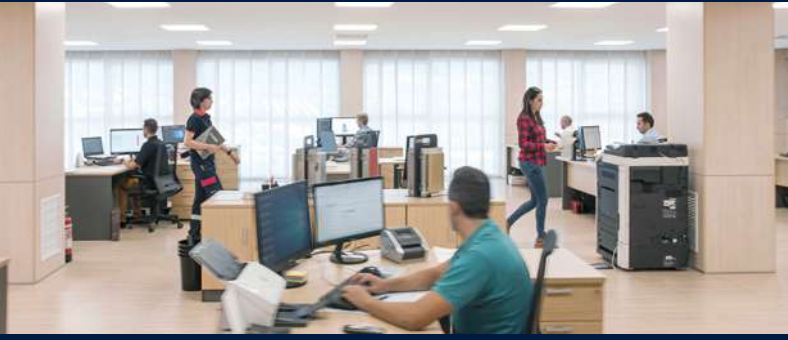

We are close to you

STAC headquarters, Spain

☎ (+34) 981 817 036

✉ info@stac.es

📍 Aldea A Matanza s.n. Pol. ind. Picusa, 15900 Padrón, A Coruña, Spain

STACBOND production center, Spain

☎ (+34) 987 553 117

✉ info@stacbond.es

📍 C/ Isaac Prado Bodelón P. 2 Pol. ind. de La Rozada 24516 Parandones, León, Spain

STAC Morocco

☎ (+212) 053952 11 36

✉ maroc@stac.es

📍 Route nationale 1, km 92, Commune rurale Laouamra, 92000 Larache, Maroc

STAC Mexico

☎ (+52) 4422517019

✉ mexico@stac.es

📍 Parque Indus. PyME, Estatal 431, Los Cues, km 5.8 Huimilpan, 76970, Querétaro, México

STAC Poland

☎ (+48) 322 630 740

✉ polska@stac.es

📍 Ul. Kluczevska 2A, 32-300 Olkusz, Poland

STAC Portugal

☎ (+351) 914 399 155

✉ portugal@stac.es

📍 Rua Cidade do Rio Grande, 13 2º Dtº Fraçao F, 3750-137 Águeda, Portugal

STAC USA

☎ (+1) 214 499 1591

✉ usa@stacbond.es

📍 228 East 45th St, Suite 9E New York, 10017 USA

STAC Türkiye

☎ (+90) 212 9360860

✉ operasyon@stac.es

📍 Halkalı Merkez Mahallesi Basın Ekspres Caddesi. Capital Tower Kat :2 No 21. Küçükçekmece İstanbul. Türkiye

Follow us!



stacbond.com