

The logo for RECKLI, featuring the brand name in a bold, white, sans-serif font. The text is contained within a black rectangular shape that has a diagonal cut on its right side, creating a trapezoidal effect. A registered trademark symbol (®) is positioned to the upper right of the brand name.

RECKLI®

**DESIGN
YOUR
CONCRETE**

Dear reader,

the façade is the face of a building. Its design has a significant influence on how a building is interpreted. As a specialist for architectural concrete, RECKLI helps your façade make an unforgettable impression. Our reusable elastic formliners guarantee the unique and economical shaping of your concrete.

RECKLI offers over 200 finished designs as well as custom design ideas. Our production combines modern machinery and traditional craftsmanship. We precisely apply unique textures, graphics, photos or three-dimensional visualizations to your façade with a high-quality finish. RECKLI formliners combine maximum design freedom with economic price tags.

Our high-quality surface finishes, such as inhibitors, concrete activators, photo-concrete-film, impregnation treatments and coating systems offer additional design and texture options.

With high standards for aesthetics and quality, as well as over 50 years of experience in research and development, we are a strong partner for the design of architectural concrete. We are trusted by planners and architects all over the world, and our experts are active in 65 countries. Our technicians, model builders, joiners, draftsmen, lab assistants and concrete technicians will provide you with competent support and will work closely with you to see your design idea become a reality.

We look forward to your project.



Executive management:

Andreas Delklock, Lutz Hammer und Sven Kosjak (f.l.t.r.)

Contents

- 4 Unique
- 12 Select
- 22 Visuals
- 28 Surface Retarder
- 29 Surface Protection
- 30 Manufacturing Process
- 32 Applications
- 34 FAQ

RECKLI®

UNIQUE

Boundless freedom
in façade design

RECKLI UNIQUE Formliners are the perfect economical solution for individual design ideas or restorations. With these elastic shapes, any design you can imagine can become part of a façade.

In close cooperation with the customer, our in-house joiners use one-off drawings to create a model of the desired design, which will later be used to create the formliner.

Custom-made formliners have proven very useful when restoring historic buildings, as they can encompass complicated motifs in exposed concrete down to the last detail. The fact that they can be reused, makes them a more economical choice.

RECKLI UNIQUE Formliners can be used to create prefabricated pieces or cast-in-place concrete.







◀
The pattern was split into seven sections and designed continuously, so that the first formliner flows into the last, allowing the pattern to continue.

»Acoustic requirements were incredibly important for our architectural decisions«

BUILDING: NOSPR Hall

ARCHITECT: Konior Studio

www.koniorstudio.pl

YEAR/LOCATION: 2014, Katowice

INTERIOR: The Polish National Radio Symphony Orchestra's NOSPR-Hall in Katowice combines optical majesty with acoustic brilliance. The patterned concrete walls feature clearly defined dimensions and depths that influence how sound is distributed. The formliners were completed according to calculations made by Acoustic Designer, Yasuhisa Toyota, and the concrete was poured in-situ. RECKLI delivered two sets, making a total of 14 formliners.

PHOTOS: Daniel Rumiancaw

ALEKSANDER NOWACKI



Vorarlberg Museum Unique

7

BUILDING: Vorarlberg Museum

ARCHITECT: Cukrowicz Nachbaur Architekten

www.cn-architekten.at

YEAR/LOCATION: 2013, Bregenz

FAÇADE: The architects worked with South Tyrolean artist Manfred Alois Mayr to create a unique concrete relief for this new building's main façade. Mayr took impressions from PET bottle bases and discovered that they made a flower. A mathematical distribution pattern was used to incorporate thirteen different bottles into the façade to create a unique floral pattern.

PHOTOS: ▶ Betonbild

▼ Adolf Bereuter for Cukrowicz Nachbaur Architekten

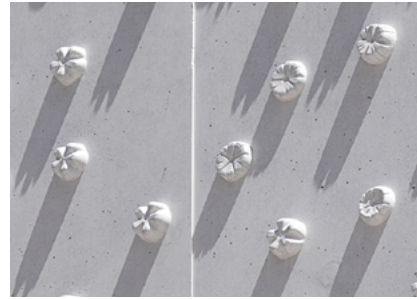

BUILDING: Two Girls Building

ARCHITECT: Billy Kavellaris, Kavellaris Urban Design (KUD)

www.kud.com.au

YEAR/LOCATION: 2015, Melbourne

FAÇADE: The 2 Girls Building blurs the line between architecture and art. The side of the building that faces the street is adorned with a portrait of two girls taken by Australian photographer Samantha Everton.

The building serves as a canvas, and becomes a piece of art itself: the pattern on the carpet in the background of the picture was implemented in patterned concrete on the façade. The lamp in the photo grows out of the image as a three-dimensional object that actually acts as lighting. Visuals, texture and sculpture have been combined in a very unique way.

PHOTO: ▶ Peter Clarke Photography





» *Image and building are one and are no longer separate entities* «

SAMANTHA EVERTON

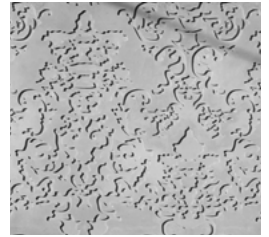

▲ Architect Billy Kavellaris turned the photographic façade into an interdisciplinary design, and continued the pattern from the carpet onto the façade using patterned concrete.



◀ RECKLI provided four custom-made formliners. The finished façade impresses with its almost seamless transition from textured concrete to DigiGlass surface.



1

Crematorium
Amiens
PLAN01

Photo: Takuji
Shimmura



2

Schinkelplatz
Berlin
Staab Architekten

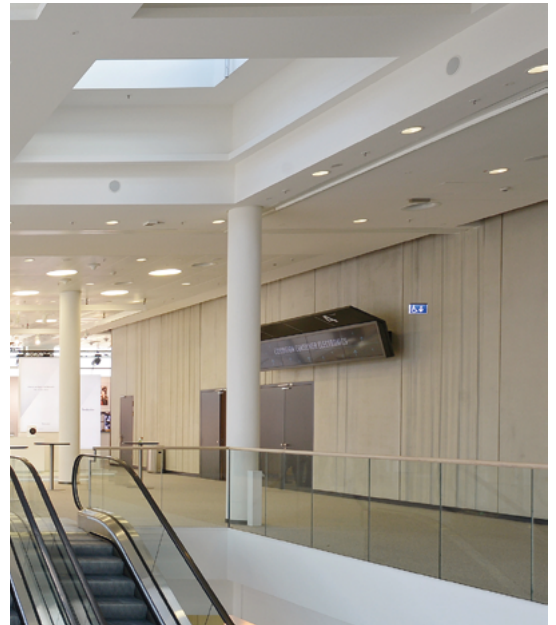

3

Kap Europa
Frankfurt
ECE Projektmanagement

4

Regional Church Office
Munich
Wandel Lorch Architekten

Photo: Anton
Schedlbauer

1
The ribbed pattern completes the design for this crematorium in Amiens, which uses round construction elements and delicate colors to create a calming atmosphere.

2
Confronted with planning requirements on everything from the plaster façade to the color spectrum, the architects transformed the plasticity of historic façades into an abstract relief.

3
In order to keep the entrance area as light and inviting as possible, the architects opted for a modest exposed concrete design with a curtain pattern.

4
A polygonal façade makes this extension of the Evangelical-Lutheran Church Office look like a pleated sculpture.



RECKLI®

SELECT

Our range of designs available
right now. Made by creatives
for creatives.



RECKLI SELECT gives architects and planners creative freedom when designing concrete façades. From natural looks to imaginative abstract patterns: the portfolio includes more than 200 designs with rock and stone patterns, masonry, wood, plaster, Oriental, abstract, non-slip textures, ribbed or waved patterns and even fractured finishes. Our elastic formliners make for completely breakage-free removal even with complicated and filigree patterns, creating an optically excellent façade without requiring a high level of maintenance. They can be reused up to 100 times, so you really get your money's worth. RECKLI SELECT formliners can be used to create prefabricated pieces and to pour cast-in-place concrete.





BUILDING: University of Navarra
ARCHITECT: Juan M. Otxotorena
www.otxotorenaarquitectos.com

YEAR/LOCATION: 2012, Pamplona

FAÇADE: The façade for the business school building hangs like a curtain made of gills along the building. The system of vertical concrete columns frames the view from the building over the green campus and vice versa.



◀
1/31
Rib Type C





BUILDING: Swimming pool building Großer Dreesch

ARCHITECT: Baukonzept
www.baukonzept.com

YEAR/LOCATION: 2015, Schwerin, Germany

FAÇADE: The new Schwerin swimming pool building is set to impress with its vertically stacked structures that come together to create a reserved façade. The vertically mounted concrete slabs have been designed with the wave-like Columbia curtain pattern, which features a range of different widths and depths that bring the façade to life. Vertical bands and blue color accents add additional texture.



▲
 2/169
 Columbia



BUILDING: Boulogne residential building

ARCHITECT: Xaveer De Geyter

WWW: www.xdga.be

YEAR/LOCATION: 2015, Paris

FAÇADE: This high-end residential building in the Parisian suburb of Boulogne features a light façade in the living area, while glossy black concrete was used on the ground floor. The architects opted for RECKLI's Travertin concrete pattern, which features irregular air holes for interest.

PHOTOS: J. Konrad Schmidt



▲
2/90
Travertin





▲
The Travertin concrete pattern is combined with black concrete for an especially high-end finish.

BUILDING: Caja de Badajoz

ARCHITECT: Studio Lamela Architects

WWW: lamela.com

YEAR/LOCATION: 2011, Badajoz

FAÇADE: Extended windows and the grooved Friesland concrete pattern give the Spanish bank Caja de Badajoz's office building a certain optical lightness. As the sun moves, the pattern creates interesting plays of light along the building's façade.

PHOTOS: Daniel Schäfer



▲ The building has become one of the province's architectural treasures.

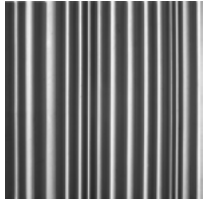

◀ 2/175
Friesland



▶ Friesland is often used horizontally. In Badajoz, it has been used vertically to create additional interest



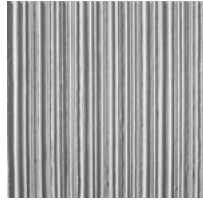

1

Mount Pilatus Panorama Gallery
Niklaus Graber &
Christoph Steiger Architekten
Alpnach
2/42 Naab



2

Bungalow @ Cove Way
Singapore
MKPL Architects
2/163 Fraser



3

Agencja Reklamy FUX
Gliwice
Łukasz Piankowski
2/174 Breisgau

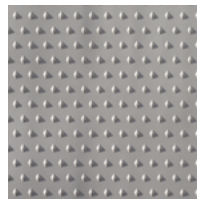

Abstract

Abstract designs play with geometric shapes, straight lines, diagonals, systematic and wild arrangement.

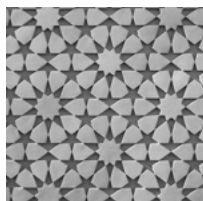

2/111 Oriental

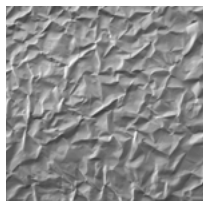

2/151 Gironde

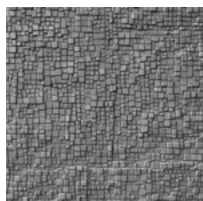

2/188 Champagne

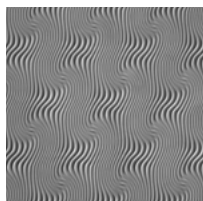

2/602 Saône

Stone & masonry

Concrete transforms into rock, rough stone, natural or rubble stones. A new brick-work look emerges with a systematic layout.

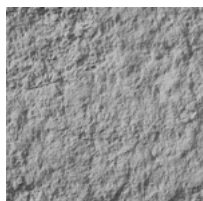

2/122 Yukon

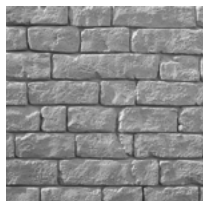

2/139 Auvergne

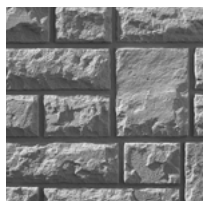

2/147 Allgäu



2/173 Santa Cruz 1-4

Wood

Grain, bamboo, reed, asymmetrically butt-joined boards: Wood patterns provide a natural look without increased care needs.



1/331 Etampes

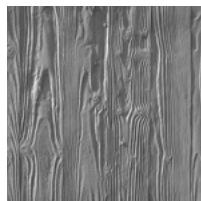

2/24 Donau

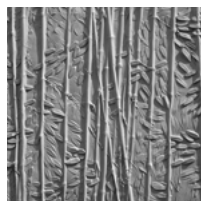

2/152 Martinique

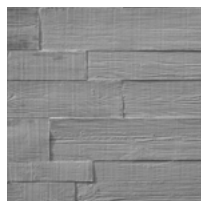

2/163 Fraser

Plaster

Plaster patterns reflect the look of various plaster methods. The effect can be accentuated with colors.



2/62 Tevere

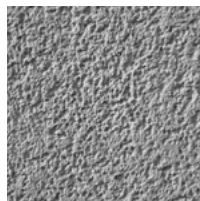

2/69 Marne

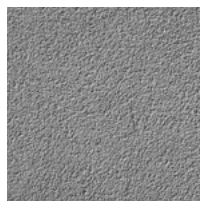

2/102 Parana

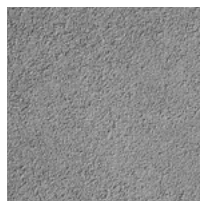

2/103 Lena

Ribs & waves

Straight-lined, chipped, broken, slanted ribs and waves optionally lend lightness or solidity.

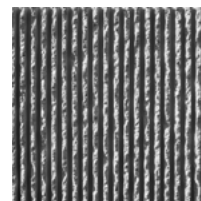

1/41B Ibiza

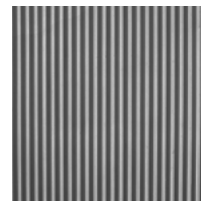

2/29 Fulda

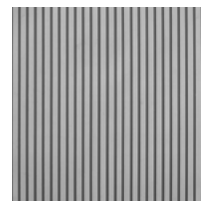

2/77 Tigris

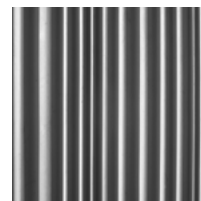

2/175 Friesland

Functional

The special surface pattern with its sand-like texture, ripples, pastilles or pimples guarantee the highest anti-slippery.

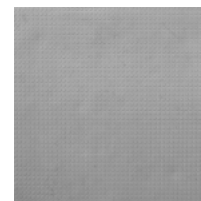

2/115 Pastilles

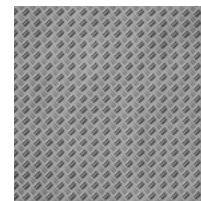

2/118 Riffel 2-Fold

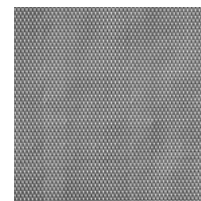

2/119 Pikes

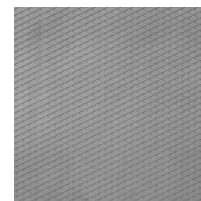

2/120 Rhombus

You can find our concrete patterns and reference buildings here:
www.rekli.com/en/products/concrete-patterns/





RECKLI®

VISUALS

Make architecture come to life.
With independent or light-
dependent visualizations.



RECKLI VISUALS formliners transfer photos to façades. Depending on the resolution of the motif, the formliner can create a detailed or rough relief on the surface. This creates the impression that the image has been carved into the concrete. The sun brings the façade to life as it moves: the image disappears in perpendicular sunlight, but sunshine from the side casts shadows over the relief that make the photo more visible in the concrete.

Artico® neo films visualize photos, images, custom designs and graphics in concrete. The plastic films transfer the motif without wrinkles or kinks, while an inhibitor allows the two-dimensional image to be precisely washed out of the concrete. This washing out means you can feel the motif on the surface. This design does not depend on light and shadow, and can be used on interior and exterior walls.

BUILDING: Edison Residence

ARCHITECTS: Kanva

WWW.KANVA.CA

YEAR/LOCATION: 2014, Montreal

FAÇADE: When planning the Edison Residence, the architects opted for historic film scenes of the old fire station in Montreal, and decided to honor the history of the site, which was destroyed by a fire years earlier. The planners chose several stills that joined together to make a sequence. The images were turned into files with 256 shades of grey, which then formed the basis of the formliners. The resulting relief patterns mean that the images are more or less obvious depending on the light.

PHOTOS: Marc Cramer

»The *historical context* has become the determining inspiration of the urban renewal project,«





▲ The chosen motifs symbolize local businesses and industries based in Toulouse.

▶ The angle of light and perspective lead to a variety of effects: indirect light highlights the photo, while direct light and shade let it fade into the background.



BUILDING: Paul Sabatier University

ARCHITECT: Espagno & Milani Architectes Associés

WWW: www.espagno-milani.fr

YEAR/LOCATION: 2009, Toulouse

FAÇADE: For the library façade design, the architect chose eight different photos made up of independent modules. The size of the photos varied from one module ($E=MC^2$) to eight modules (Marie Curie). A detailed plan defined the configuration of the façade and included complete photos as well as a repetition of certain modules to create the impression of an infinite photo collage.

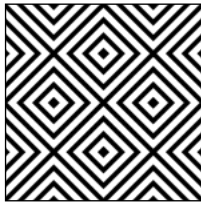

▲RECKLI
artico® neo Design
Be Squared

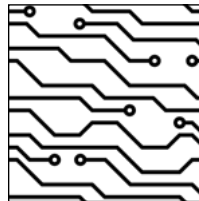

▲
RECKLI
artico® neo Design
Big Data

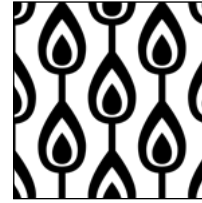

▲
RECKLI
artico® neo Design
Flames Of Paradise

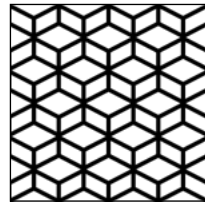

▲
RECKLI
artico® neo Design
Cubes



FAÇADE: Inhibitors and acidification products can turn exposed aggregate concrete into a modern design element. It combines optical effects with practical benefits such as non-slip finishes. The surfaces are treated in accordance with DIN V 18500: when the concrete is washed out, the top layer of cement is removed up to a depth of 1/3 coarse grit so that the aggregate comes into its own. The use of colored aggregate such as granite, marble, basalt or gravel gives the surface a unique texture.



POSITIVE PROCESS: In a positive process, the concrete is poured into the casing. After removal and smoothing, the inhibitor is applied to the fresh surface. This can be washed out in 5 hours to 3 days.

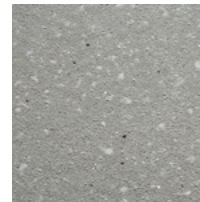

Nano

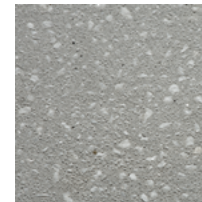

Fine



Washed

NEGATIVE PROCESS: In a negative process, the inhibitor is applied to the casing first. After this has dried, the concrete is poured in. After 15 to 24 hours, the concrete element can be removed and washed.

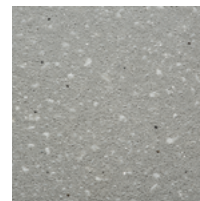

Nano

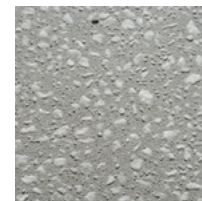

Fine



Washed

FAÇADE: Surface Protection systems shield exposed concrete surfaces from water, dirt and graffiti. Water can allow harmful substances, microorganisms and salts to enter the concrete surfaces. These substances gradually attack the construction and lead to cracks or spalling.

RECKLI's protection systems seal young and old visible concrete surfaces either colorlessly or with an optical effect. They're suitable for treating prefabricated concrete parts, cast-in-place concrete, artificial stone and terrazzo flooring.

ILLUSTRATION: ▲ Jens Amende

▶ Concrete surface without protection

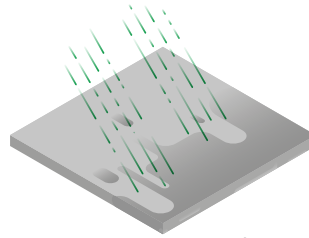

▶ Concrete surface with protection

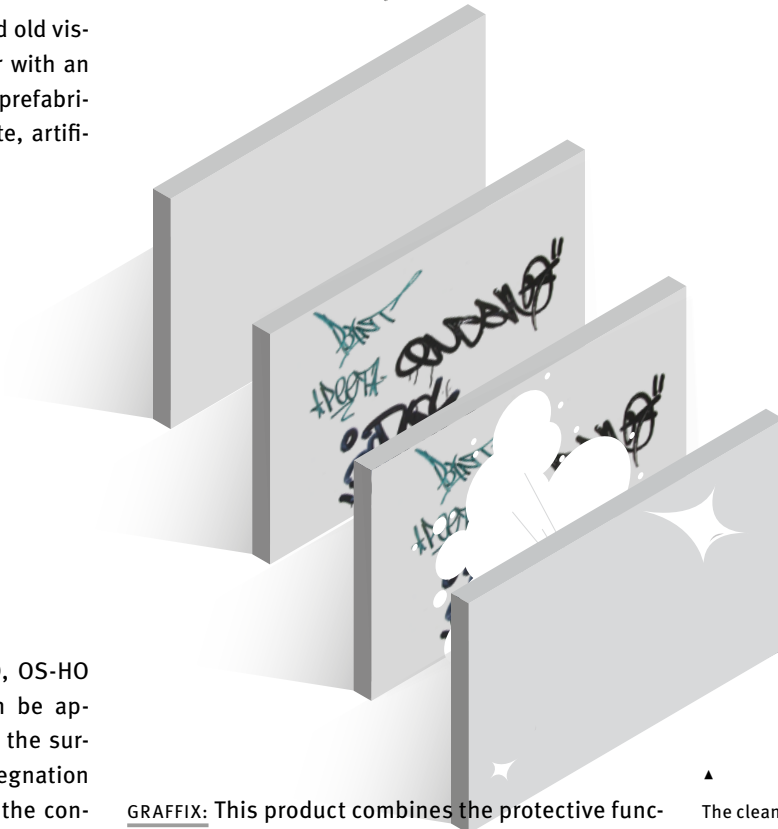
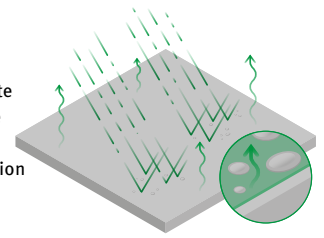

COLORLESS IMPREGNATION: The RECKLI OS-D, OS-HO and OS-Premium protection systems can be applied to uncured concrete. They soak into the surface and create a chemical bond. As impregnation treatments don't form a film, the color of the concrete surface remains unchanged.

EFFECT IMPREGNATION: RECKLI OS-Intensive and OS-W are especially suitable for processed and absorbent surfaces such as exposed aggregate concrete, patterned concrete, sandblasted or acidified concrete. The protection systems can be applied to uncured concrete. The materials soak into the surface and create a film with a matte to glossy sheen that intensifies the color of the concrete.

GRAFFIX: This product combines the protective functions of a colorless impregnation treatment with permanent graffiti protection. Graffix leaves the color of the concrete surface unchanged. It can be applied to uncured concrete before it leaves the precast plant. Other materials mostly need 28 days to harden. With our own cleaning solution, RECKLI Graffix Cleaner, graffiti can be washed off without destroying the protective film. This makes maintaining the façade especially easy and economical.

▲ The cleaning process can take place up to 5 times. Thereafter, the surface has to be re-impregnated.

The production of RECKLI formliners follows a simple principle: At the beginning lies the inspiration in nature or on a computer. A positive cast is subsequently created in combining traditional craftsmanship and state-of-the-art technology and is then followed by an elastic form.

1
The original forms for concrete patterns and some individual patterns are created by hand. They are molded out of plaster or cast of existing patterns. The models for the photo-concrete and single individual pattern are done digitally. An individual design or an image are transferred into a file for the CNC-mill by a computer. It cuts the pattern into board material (Exception: artico® neo)

2
The positive cast is sealed with a release wax and provided with a forming frame. Subsequently, a liquid elastomer is poured onto the cast to produce the formliner.

3
After the synthetic solidifies, the forming frame can be removed. The high elasticity of the formliner enables a reproduction of the pattern that is true to detail and makes it robust enough to be reused multiple times (up to 100 times).

4
The formliner is glued to the mold and waxed with release agents before the concrete is cast.

5
The formliner can be used at the precast plant and in the in-situ concrete.

6
After the concrete has hardened, the element can be removed with no problem.

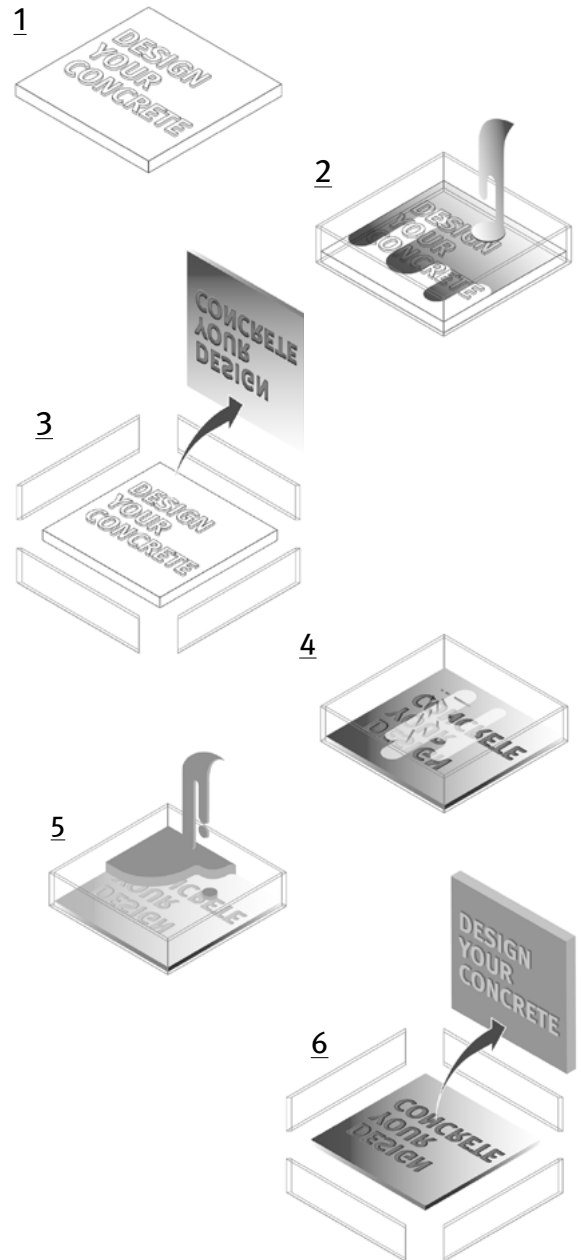

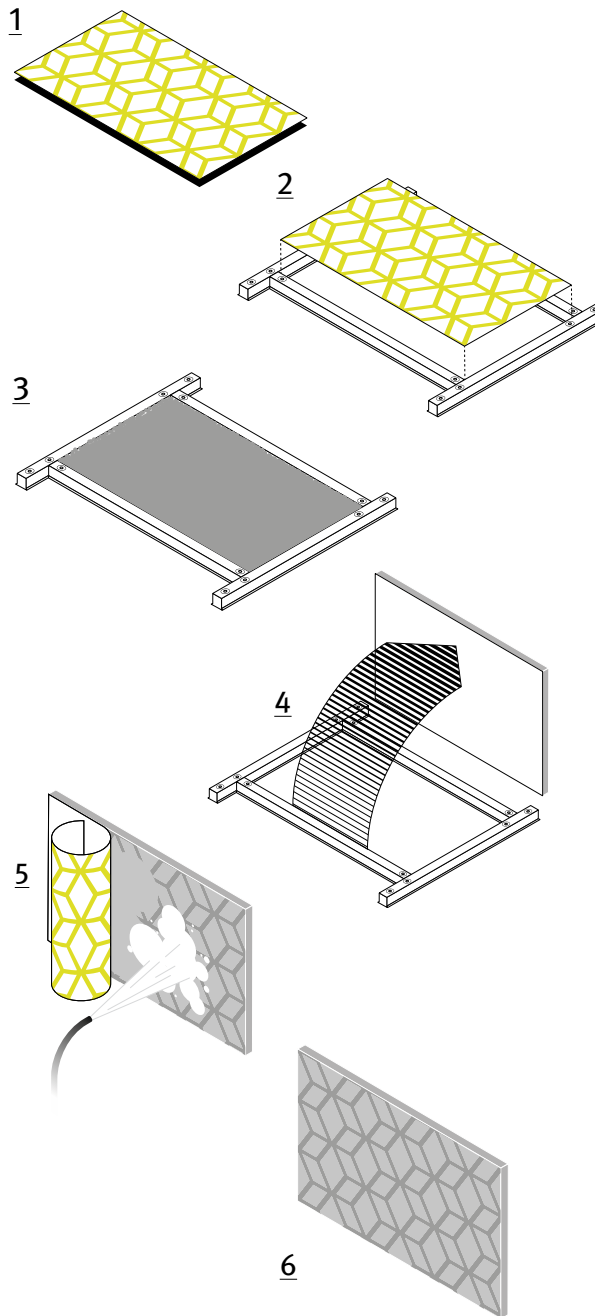

The process is simple: RECKLI artico® neo is a plastic foil on which graphics or photos are printed with a high-quality concrete activator. The concrete activator causes the concrete to set at a different time so that it can be washed out on the surface after demolding. The uppermost cement skin is partially removed. The contrast between the washed out and smooth surfaces makes the graphics or photos visible. The foils are intended for single use.

1
RECKLI prints the design onto a special foil.

2
The artico foil is laid into the mold.

3
The cement is poured into the mold.

4
Once the cement has hardened, the concrete element can be unmolded.

5
The foil is simply removed from the concrete element and the concrete is washed out with a high-pressure cleaner.

6
The interplay of washed out and smooth surfaces makes the design visible.

RECKLI products are suitable for almost all building projects – from floral patterns to concrete photos, from a garden wall to a massive façade.

Commercial buildings



Customer service center
(Photo: Eckhart Matthäus)

Supermarket



Regional church office
(Photo: Anton Schedlbauer)

Communal buildings

Swimming pool



Bridges and tunnels



Bridge



Bridge



Underpass



Hospital



School (Photo: Matthieu Gafsou)



Museum

Floors

Tactile paving



Decorative flooring



Non-slip flooring

Walls



Privacy wall



Flood protection



Noise barrier

Residential Buildings

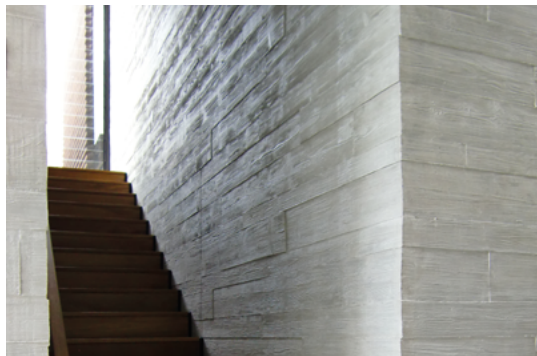

Interior design

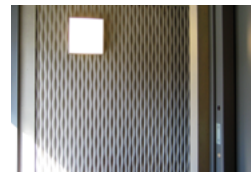

Stairwell



Residential building façade

I'm building with a very tight budget. Are RECKLI products even suitable for my project?

RECKLI formliners can be used for small and large building projects. With our elastic formliners, you can economically implement design ideas from a small logo to a garden wall or a vast façade. The formliners are stretchy yet robust and can be re-used up to 100 times so you get the most out of your budget. Their elasticity guarantees high-quality results with homogenous, detailed surfaces without broken edges. No need for expensive repair work.

Where can I find out more about RECKLI products?

You can find more information on RECKLI formliners, instructions, product brochures, our pattern book and our magazine FORMLINER on our website: → www.reckli.com/en/service
Any questions? Give us a call: +49 2323 1706-0 or write to us: → info@reckli.com

Does RECKLI also supply the concrete?

RECKLI is in touch with a large network of concrete producers and precast plants, so we can help you find the perfect partner. Our formliners can be used to create prefabricated parts or cast-in-place concrete.

Is using RECKLI formliners complicated?

RECKLI formliners are easy to use, which is why they're popular in a wide range of areas from façade design to flooring and interior design. Our elastic formliners can be delivered to a precast plant or construction site. They are glued to the casing and treated with release agents, then are ready for concreting. Once the concrete is hardened, the casing is removed and the formliner can be used again.

Who should I contact?

RECKLI experts support our customers all around the world through each phase of their projects. We have technicians and advisors in many regions to provide our customers with competent specialized knowledge. You can see all our contact partners on our website:
→ www.reckli.com/en/contact/branches-worldwide

Contact

RECKLI GmbH
Gewerkestraße 9a, 44628 Herne
T +49 2323 17060 | info@reckli.com
www.reckli.com

