

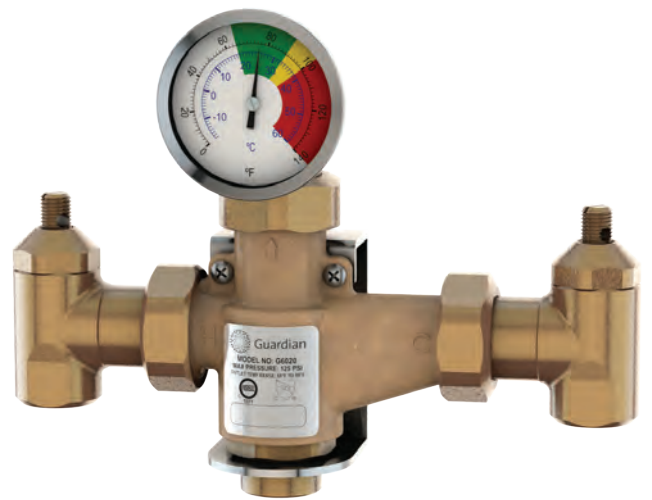

Guardian

EMERGENCY EYEWASH & SHOWER TECHNOLOGY



Thermostatic Mixing Valves for Emergency Equipment

Guardian Equipment is pleased to introduce a new and innovative range of thermostatic mixing valves for use with emergency eyewash and shower equipment. The new Guardian valves are engineered specifically for the critical demands of emergency applications. They offer superior functionality and important advantages over valves currently in use today.

Emergency eyewashes and showers deliver high volumes of water to rinse away hazardous chemicals in the event of an accident or spill. The safety of the user requires that the water be a safe and comfortable temperature. For that reason, in 2014, ANSI Standard Z358.1 “Emergency Eyewash and Shower Equipment” was revised to provide that the water delivered by emergency equipment be “tepid.” Tepid water is defined as between the temperatures of 60°F (16°C) and 100°F (38°C).

This temperature range is intended to be a guideline rather than a definitive requirement. The ideal delivered water temperature will depend upon the nature of the hazard in the work environment. In some cases, tepid water can accelerate a chemical reaction and make a bad situation worse. A medical professional should be consulted before determining the optimal delivered water temperature.

There are several ways to deliver tepid water to an emergency eyewash or shower unit. The most common is to provide a supply of hot and cold water to the emergency unit and, when the unit is activated, blend the water to a preset temperature. A thermostatic mixing valve is installed upstream of the emergency unit to sense the temperatures of the hot and cold water and blend the water to the desired temperature.

Thermostatic mixing valves used with emergency equipment are not like mixing valves used in other plumbing applications. These valves must be designed for this critical application and offer:

High Capacity: In an emergency, more water means faster and more effective rinsing. Thermostatic mixing valves must provide the high volumes of water required by emergency equipment, particularly when supplying more than one unit.

Uninterrupted Supply of Water: If the supply of hot water is interrupted, the valve must still deliver cold water in the volume required for the emergency unit to function effectively.

Scald Protection: If the supply of cold water is restricted or interrupted, the valve must shut off completely and not deliver any water at all. Leakage through the valve can cause scalding of the user.

Reliability: Valves must be foolproof so they will work when they are needed, regardless of how often inspection, testing and maintenance are performed. Valves should have features such as all-brass construction, a durable precision temperature actuator, internal filters to prevent debris from entering the valve and a high temperature limiting feature.

Because of these special characteristics, the American Society of Sanitary Engineering developed ASSE Standard No. 1071 “Performance Requirements for Temperature Actuated Mixing Valves for Plumbed Emergency Equipment”. In 2012, ANSI approved this as a national standard. ***All Guardian thermostatic mixing valves are certified to meet or exceed the requirements of ANSI/ASSE 1071.***

Guardian is the only manufacturer of emergency eyewash and shower equipment that has specialized exclusively in this field. All of our competitors manufacture and sell various other unrelated product lines. For Guardian, emergency equipment is all we do. We have applied this single-minded focus to the design and engineering of these new thermostatic mixing valves. We know that someone’s well-being will depend on it.

There are many valves on the market that can be used with emergency equipment. Most offer one or two features that may make them preferable to competing products. Only Guardian valves offer a comprehensive combination of features that make them superior to all other competing products. No other manufacturer offers all of the following:

High Capacity

Guardian valves deliver among the highest flow rates in the industry. The G6020 valve has a capacity of 13 gallons (49 liters) per minute at a 30 PSI (2.1 bar) pressure drop, more than any other valve in its class. The G6040 valve has a capacity of 50 gallons (189 liters) per minute.

High Bypass Flow

When delivering cold water only (bypass mode), Guardian valves also deliver among the highest flow rates in the industry. The G6020 delivers 9 gallons (34 liters) per minute of cold water if the hot water is shut off. The G6040 delivers 38 gallons (144 liters) per minute if the hot water is shut off.

Positive Hot Water Shutoff

Guardian valves have an internal PTFE valve seat. In the event the cold water supply is interrupted, the valve piston closes against the PTFE seat. The soft seat assures that there is a positive seal and no water can escape the valve. There is no risk of the user being exposed to scalding water.

Fast Response Time

ANSI/ASSE 1071 allows up to one minute for a thermostatic mixing valve to stabilize after changes in incoming water temperature or pressure. In the meantime, the user of the safety equipment might be exposed to uncomfortable or even dangerous water temperatures. Guardian valves respond to changes in seconds, protecting the safety of the user.

High Temperature Fail-Safe

Valves have a high temperature limit stop factory set at 90°F (32°C) degrees. The limit stop prevents accidental adjustment of the valve beyond the recommended temperature range.

High Supply Pressure Differential

In many facilities, there is a significant difference between the pressure of the hot water and cold water supplies. Most thermostatic mixing valves will not perform properly if this difference in pressure is more than 5 or 10%. Guardian valves do not have this limitation. Guardian valves will provide the required tepid water flow and temperature even if the pressure differential is as much as 25%.

Low Profile

Thermostatic mixing valves are often installed in tight spaces, including inside wall cavities and underneath sinks. Guardian thermostatic valves are less than 3-3/4" (95mm) deep. *All of our valves can be installed in a 3-5/8" (92mm) partition wall, even when installed in a recessed cabinet.*

Flexible Installation

The position of the valve inlets and outlet are adjustable. Inlets can be rotated to accommodate supplies from the top, back or bottom. The outlet can be positioned on either the top or bottom of the valve. The valve can be configured in the field for whatever piping configuration is desired.

Factory Assembly and Testing

Every Guardian valve is fully assembled and individually factory tested. Valves can be installed quickly and confidently.

More Standard Features

Guardian thermostatic mixing valves have more standard features than any other valve, including:

- A temperature gauge to monitor the delivered water temperature is standard, not optional.
- A mounting bracket for installation is standard, not optional.
- Lockable shutoff valves on the hot and cold water inlets are standard, not optional.
- Stainless steel wire mesh basket filters on the cold and hot water supplies are standard, not optional. The filters are designed to catch debris and push it out of the water stream, so the water flow is not restricted.

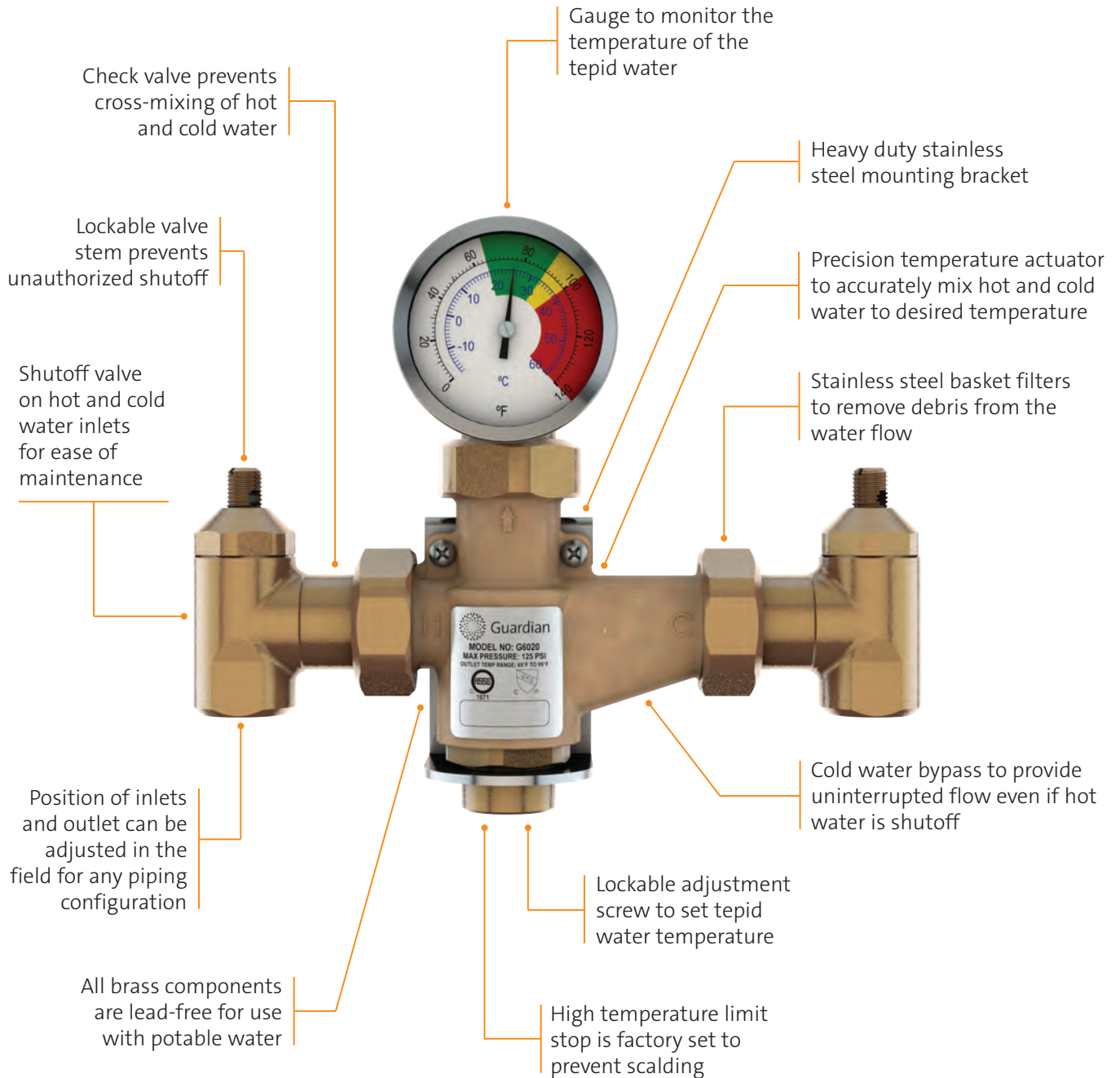

G6020 Thermostatic Mixing Valve, 13 Gallon/49 Liter Capacity

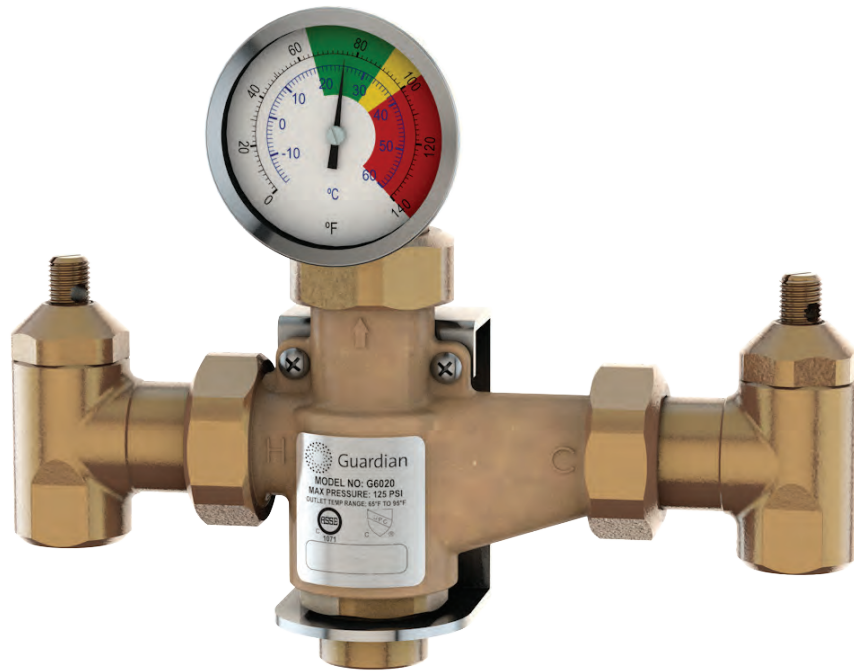

Application: Thermostatic mixing valve to blend hot and cold water to deliver tepid water. Valve has flow capacity of 13 gallons (49 liters) per minute at 30 PSI (2.1 bar) pressure drop. Valve can be used to supply emergency eyewash, eye/face wash or drench hose unit. Depending on water supply size and pressure, valve can supply multiple units.

Mounting: Valve inlets can be positioned on top, back or bottom of valve. Outlet can be on top or bottom. Valve can be configured in the field for any mounting position. Furnished with heavy duty stainless steel mounting bracket.

Temperature Control: Valve has precision thermal actuator that senses incoming water temperature and automatically blends water to preset temperature. Valve is factory set to deliver 85°F (29°C) water. Temperature of tepid water can be adjusted as required and then locked. Furnished with dial temperature gauge as standard to monitor temperature of tepid water.

Cold Water Bypass: If the supply of hot water is restricted or interrupted, an internal bypass allows the valve to deliver cold water only. In bypass mode, the valve delivers 9 GPM (34 L/min) at 30 PSI (2.1 bar) pressure drop.

Hot Water Shutoff: Valve has internal PTFE valve seat. If the supply of cold water is interrupted, the valve will close completely and *not deliver any water at all*, eliminating any possibility of scalding.

Flow Capacity: Refer to table below for flow capacity of valve at specified pressure drops.

Checkstops/Filters: Each inlet has a lockable shutoff valve for maintenance, internal check valve to prevent backflow and stainless steel basket filter to remove debris from the water flow.

Construction: Valve meets the requirements of the U.S. Safe Drinking Water Act as lead-free.

Inlet/Outlet: 1/2" NPT female inlets and outlet as standard.

Quality Assurance: Valve is ASSE certified under ANSI/ASSE 1071. Valve is fully assembled and factory tested prior to shipment.

Water Pressure/Temperature Requirements

Supply Pressure: Maximum incoming water pressure is 125 PSI (8.6 bar). Pressure of hot and cold water supplies can vary up to 25% and still deliver the flow and temperature required by ANSI/ASSE 1071.

Hot Water Supply Temperature: Incoming hot water temperature range is 120° - 180°F (49° - 82°C). Guardian recommends that the hot water temperature not exceed 140°F (60°C).

Cold Water Supply Temperature: Incoming cold water temperature range is 40° - 70°F (4° - 21°C). Cold water temperature must be at least 10°F (5.6°C) less than the temperature of the delivered tepid water.

Tepid Water Temperature: Temperature of tepid water is adjustable within a range of 65° - 95°F (18° - 35°C) and then locks in position. High temperature limit stop is set at 90°F (32°C) to prevent misadjustment.

G6020 Thermostatic Mixing Valve, 13 Gallon/49 Liter Capacity

Pressure Drop (PSI)	1	5	10	15	20	25	30	35	40
Flow Rate (GPM)	3	5	7	8	10	11	13	13	14
Bypass Flow Rate (GPM)	3	4	5	6	7	8	9	9	10

Pressure Drop (Bar)	0.1	0.3	0.7	1.0	1.4	1.7	2.1	2.4	2.8
Flow Rate (L/min)	11	19	26	30	38	42	49	49	53
Bypass Flow Rate (L/min)	11	15	19	23	26	30	34	34	38

Ordering Information

Models

<input type="checkbox"/>	G6020	Thermostatic Mixing Valve, 13 Gallon/49 Liter Capacity
<input type="checkbox"/>	G6021-XXX	G6020 valve installed in surface mounted powder coated steel cabinet
<input type="checkbox"/>	G6022-XXX	G6020 valve installed in surface mounted stainless steel cabinet
<input type="checkbox"/>	G6023-XXX	G6020 valve installed in recess mounted powder coated steel cabinet
<input type="checkbox"/>	G6024-XXX	G6020 valve installed in recess mounted stainless steel cabinet

Available Options

<input type="checkbox"/>	Finish	Chrome plated finish in place of raw brass (add suffix "CP")
<input type="checkbox"/>	Inlet/Outlet Threads	G1/2 female thread on inlets and outlet (add suffix "G")
<input type="checkbox"/>	Temperature Gauges	Temperature gauges on hot and cold water inlets (add suffix "IT")
<input type="checkbox"/>	Pressure Gauges	Pressure gauges on hot and cold water inlets (add suffix "IP")
<input type="checkbox"/>	Temperature/Pressure Gauges	Temperature and pressure gauges on hot and cold water inlets (add suffix "ITP")

Note: Installation of temperature and/or pressure gauges will change rough-in dimensions of valve. Contact factory for catalog drawing.

G6020 Thermostatic Mixing Valve, 13 Gallon/49 Liter Capacity

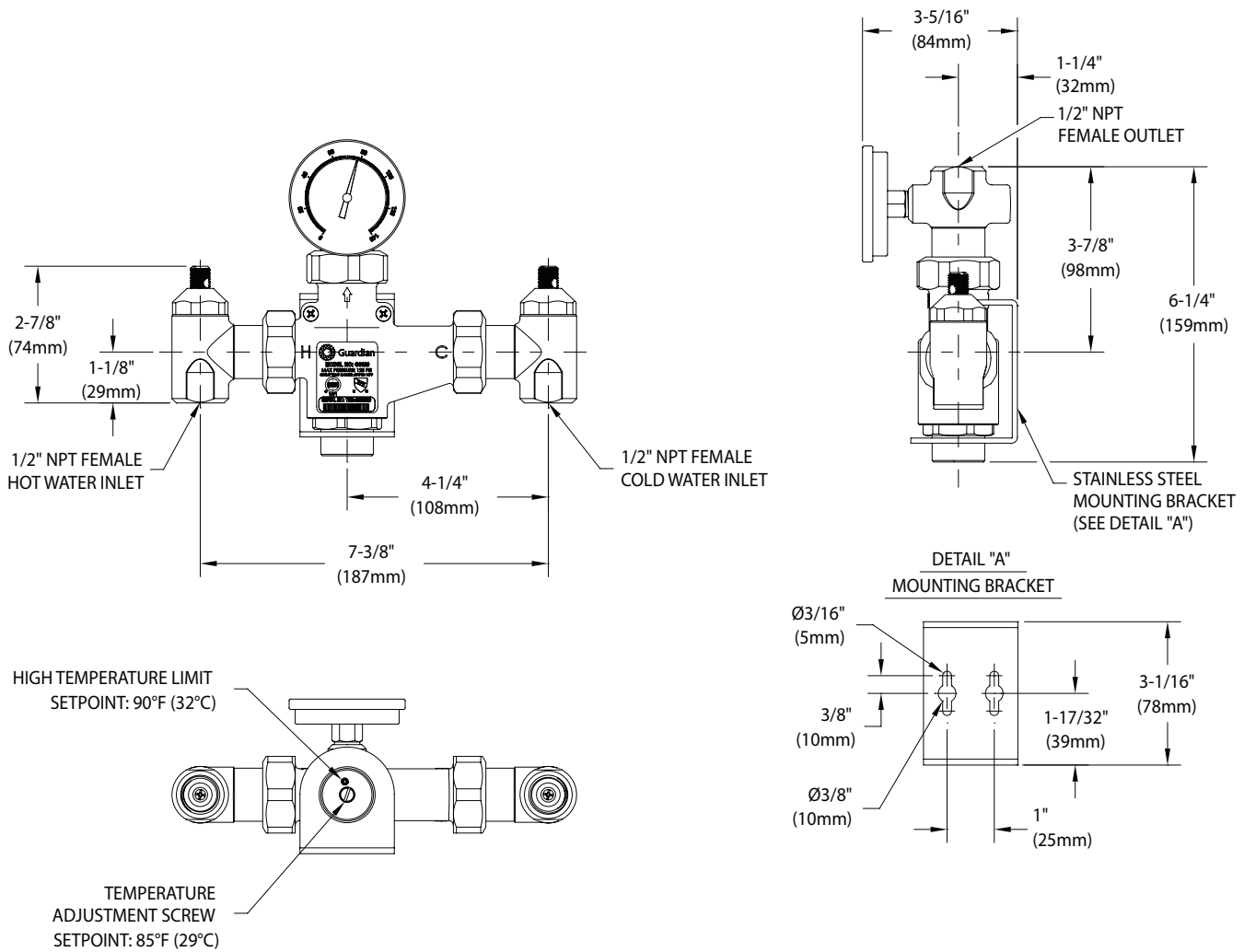

Notes:

- ANSI Z358.1-2014 states that the water temperature delivered by emergency equipment should be "tepid". Tepid is defined as 60°F - 100°F (16°C - 38°C). However, in circumstances where a chemical reaction can be accelerated by water temperature, a medical professional should be consulted to determine the optimum water temperature for the application.
- For thermostatic mixing valves to deliver the required water temperature and volume, the water system must be sized correctly. Please refer to the flow capacity, pressure and temperature requirements herein when designing the tepid water system.
- Valve is factory set to deliver 85°F (29°C) tepid water. Depending on pressure and temperature of the incoming water supplies, this setting may require adjustment in the field. The adjustment screw is locked in position after adjusting.
- Thermostatic mixing valves, like all emergency equipment, must be installed in accordance with the manufacturer's instructions and maintained on a regular basis. Per ANSI Z358.1-2014, all emergency equipment should be activated weekly and inspected at least annually. Thermostatic mixing valves should be treated the same.
- Per ANSI Z358.1-2014, plumbed emergency equipment must be connected to a potable water supply. This valve meets the requirements of the U.S. Safe Drinking Water Act as lead-free and is safe for use with potable water.
- This valve is supplied with shutoff valves. Per ANSI Z358.1-2014, if shutoff valves are installed on the water supply to emergency equipment, the valves must be lockable to prevent unauthorized shutoff. Accordingly, each shutoff valve stem on this valve has a hole for installing a lock to secure the stem in the open position.

THIS SPACE FOR ARCHITECT/ENGINEER APPROVAL

Due to continuing product improvement, the information contained in this document is subject to change without notice. All dimensions are ± 1/4" (6mm). Rev. 022420



G6021-XXX G6020 Thermostatic Mixing Valve with Surface Mounted Powder Coated Steel Cabinet

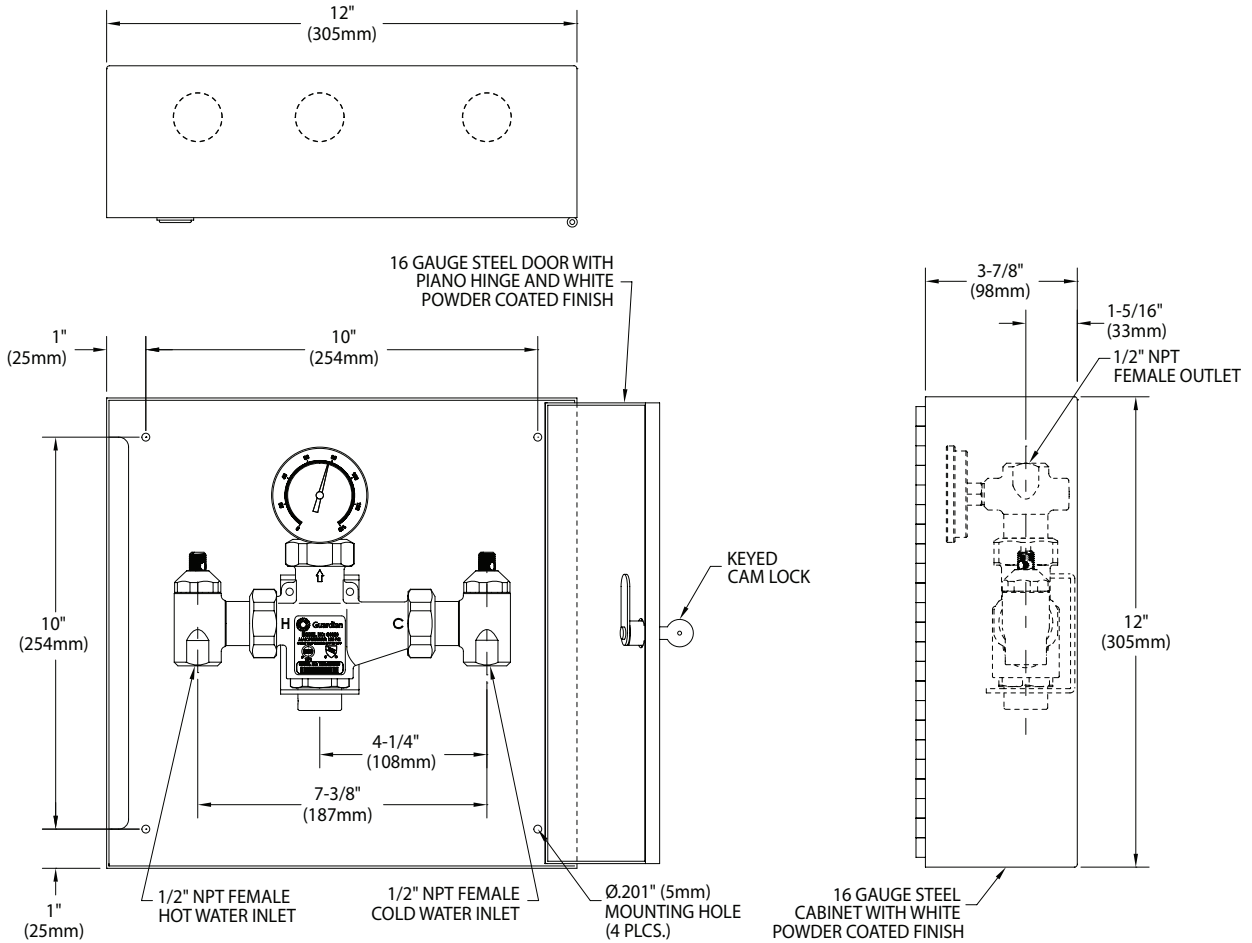

Ordering Information

When ordering the G6021-XXX, the three digit code added to the model number specifies the following information. If no code is specified, the unit will be supplied with code 1R1 (solid door, right hinge and bottom inlets/top outlet).

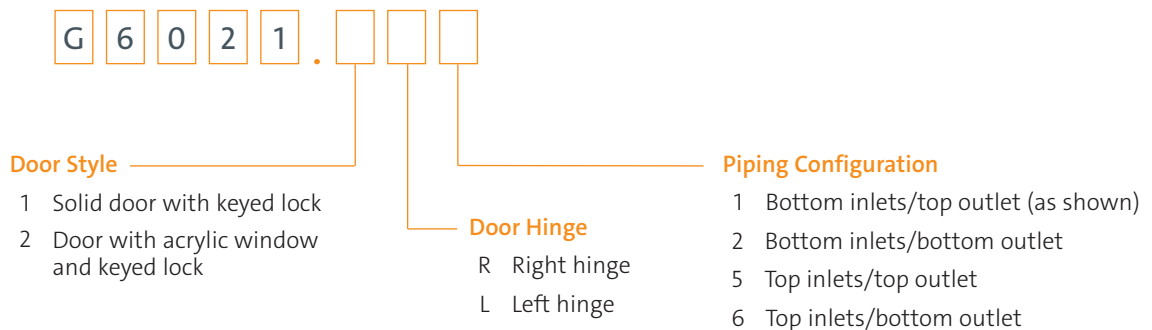

G6022-XXX G6020 Thermostatic Mixing Valve with Surface Mounted Stainless Steel Cabinet

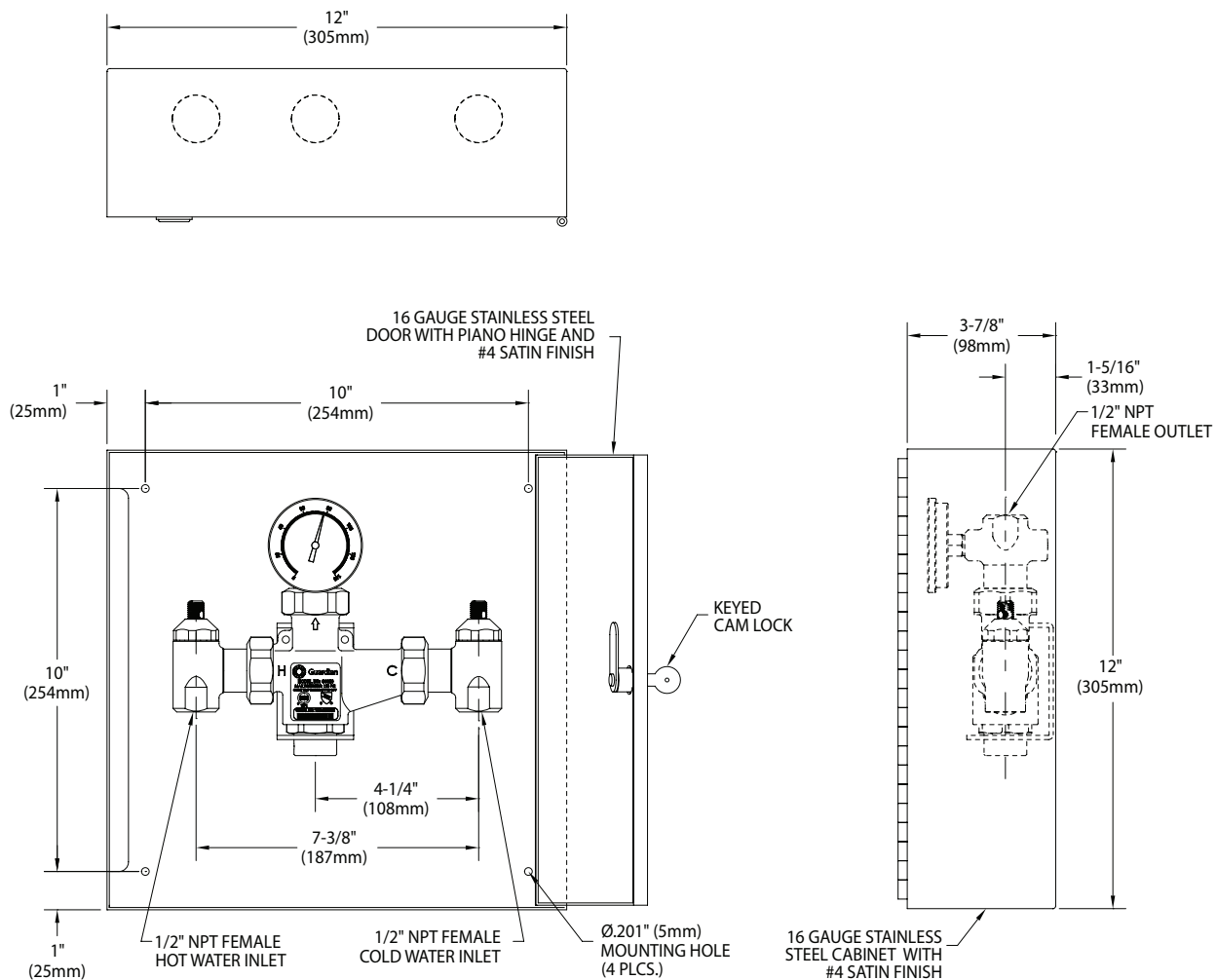

Ordering Information

When ordering the G6022-XXX, the three digit code added to the model number specifies the following information. If no code is specified, the unit will be supplied with code 1R1 (solid door, right hinge and bottom inlets/top outlet).

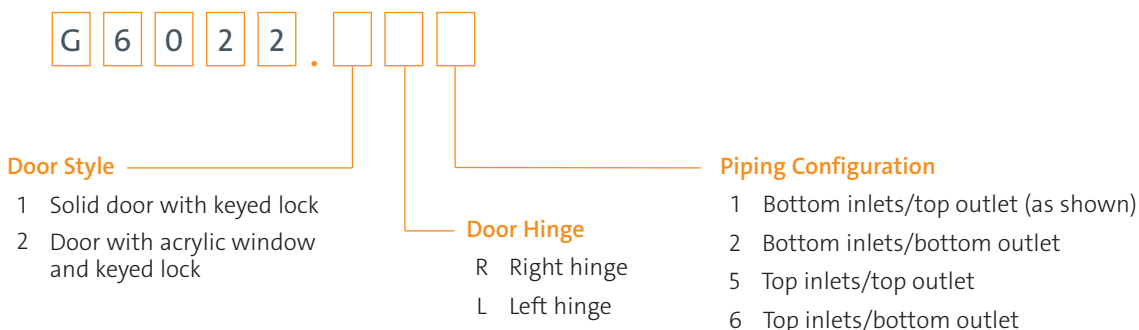

G6023-XXX G6020 Thermostatic Mixing Valve with Recess Mounted Powder Coated Steel Cabinet

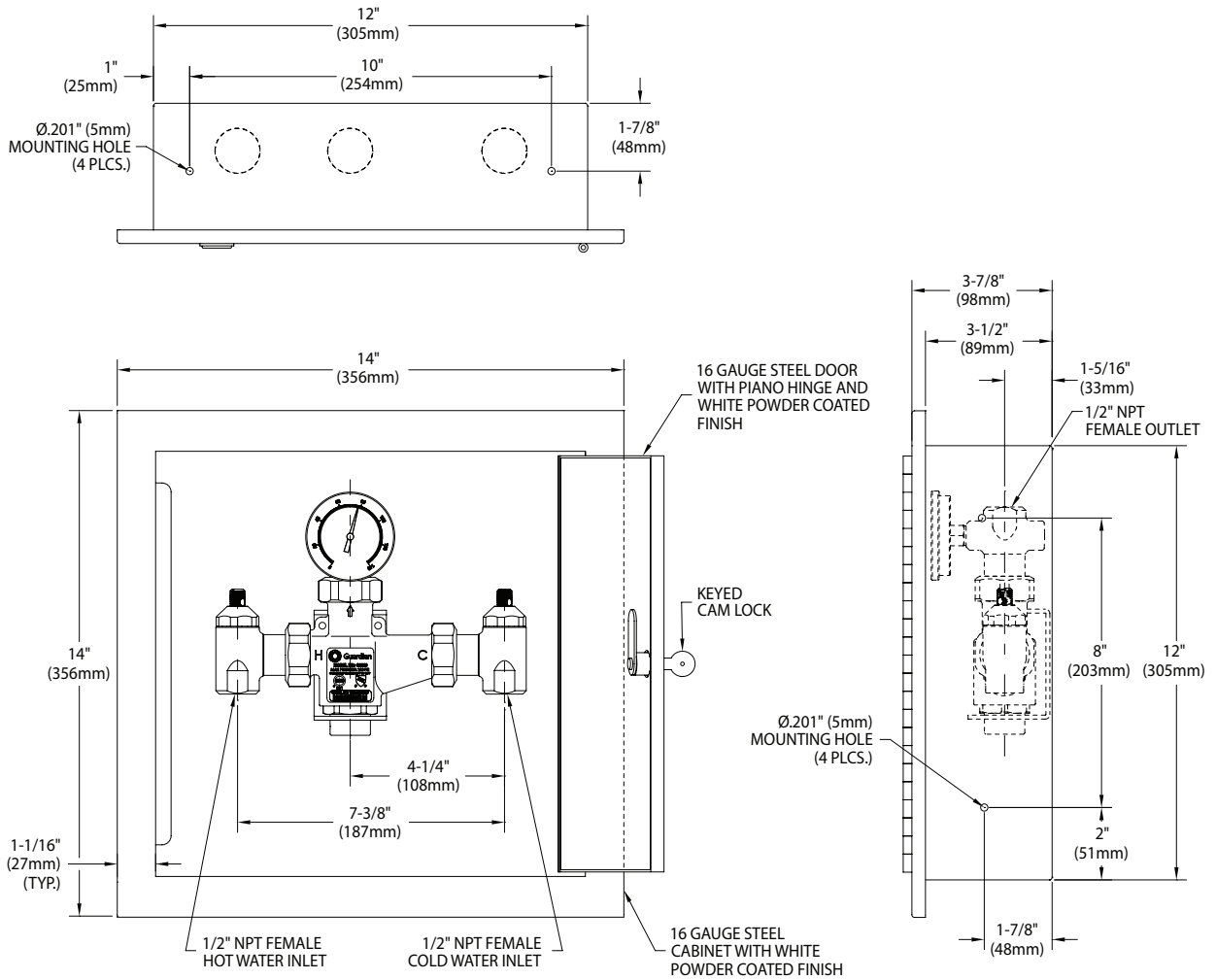

Ordering Information

When ordering the G6023-XXX, the three digit code added to the model number specifies the following information. If no code is specified, the unit will be supplied with code 1R1 (solid door, right hinge and bottom inlets/top outlet).

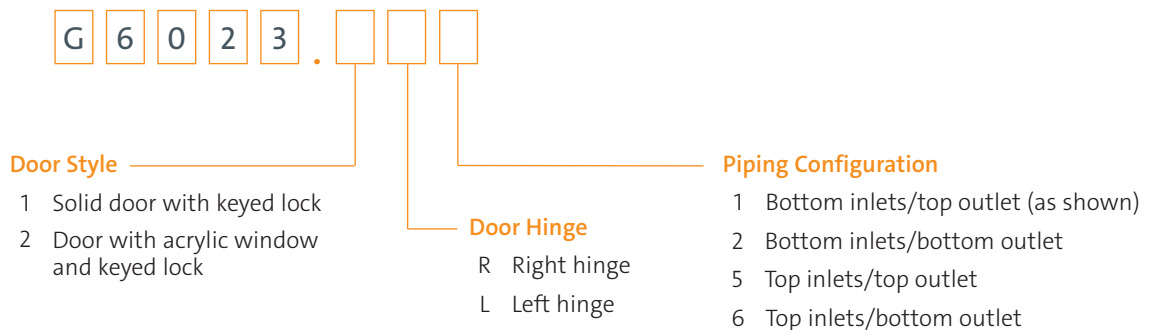

G6024-XXX G6020 Thermostatic Mixing Valve with Recess Mounted Stainless Steel Cabinet

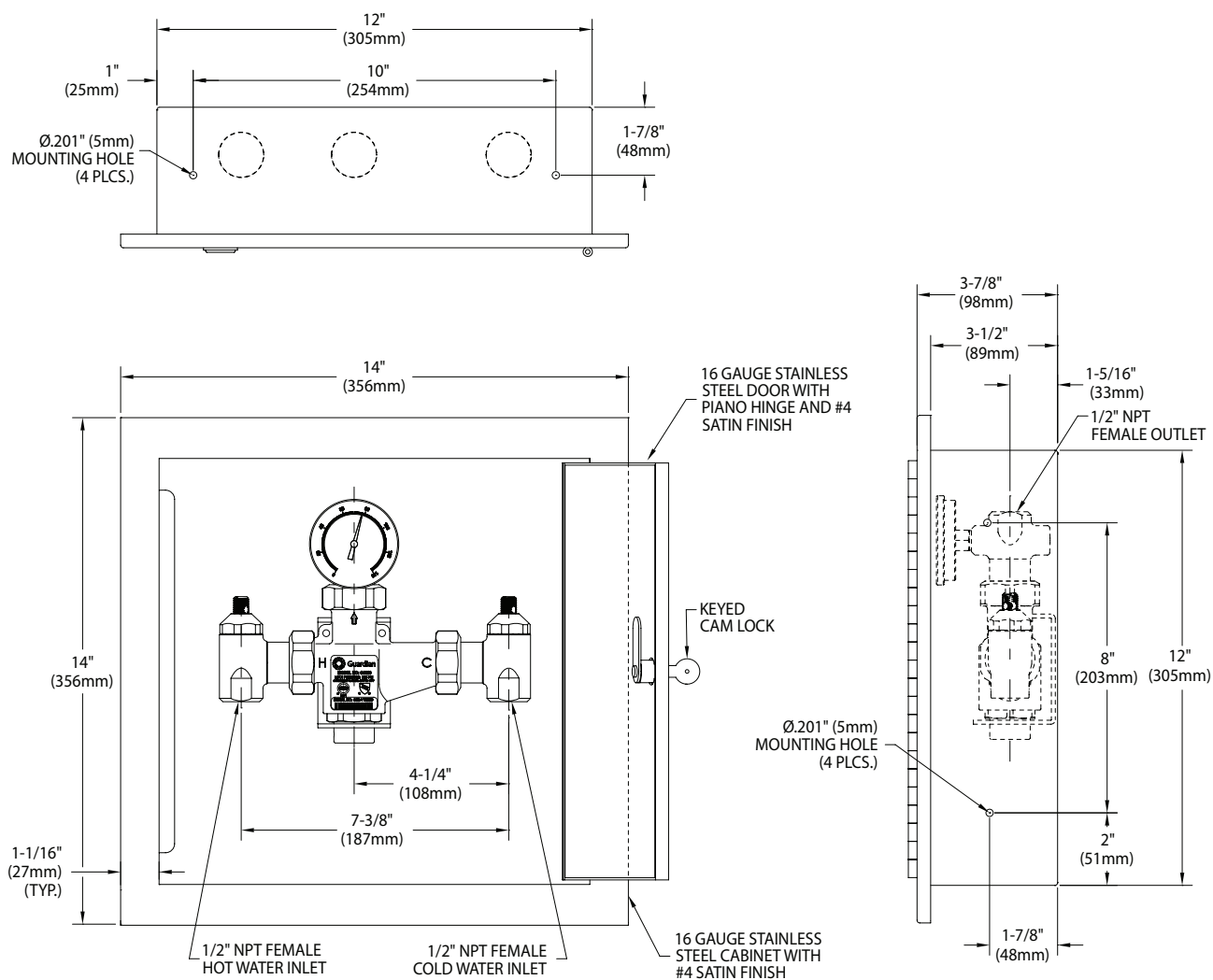

Ordering Information

When ordering the G6024-XXX, the three digit code added to the model number specifies the following information. If no code is specified, the unit will be supplied with code 1R1 (solid door, right hinge and bottom inlets/top outlet).

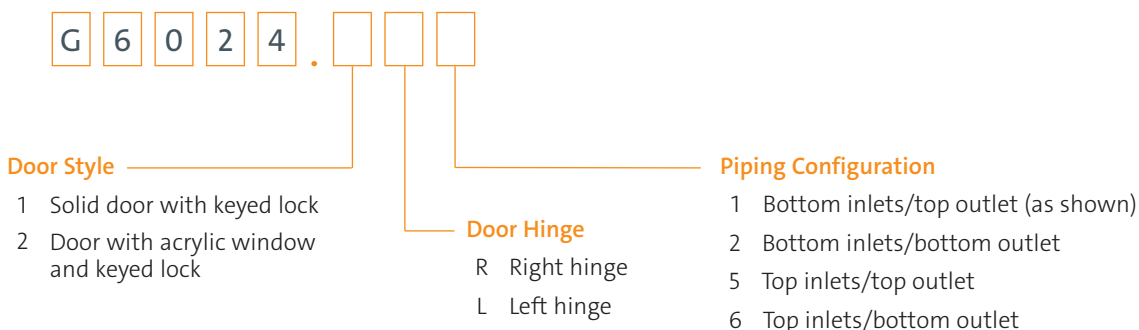

G6040 Thermostatic Mixing Valve, 50 Gallon/189 Liter Capacity

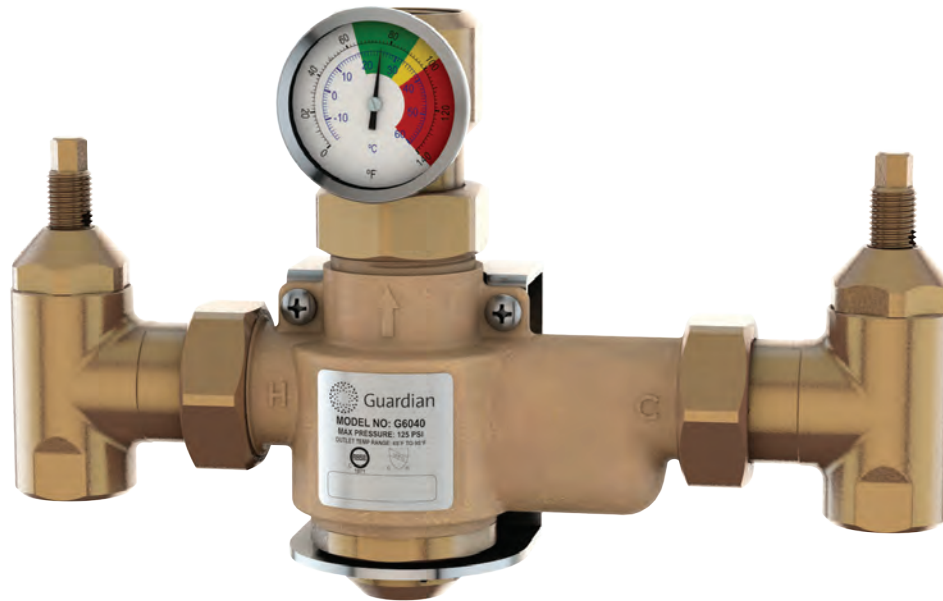

Application: Thermostatic mixing valve to blend hot and cold water to deliver tepid water. Valve has flow capacity of 50 gallons (189 liters) per minute at 30 PSI (2.1 bar) pressure drop. Valve can be used to supply emergency shower or combination safety station. Depending on water supply size and pressure, valve can supply multiple units.

Mounting: Valve inlets can be positioned on top, back or bottom of valve. Outlet can be on top or bottom. Valve can be configured in the field for any mounting position. Furnished with heavy duty stainless steel mounting bracket.

Temperature Control: Valve has precision thermal actuator that senses incoming water temperature and automatically blends water to preset temperature. Valve is factory set to deliver 85°F (29°C) water. Temperature of tepid water can be adjusted as required and then locked. Furnished with dial temperature gauge as standard to monitor temperature of tepid water.

Cold Water Bypass: If the supply of hot water is restricted or interrupted, an internal bypass allows the valve to deliver cold water only. In bypass mode, the valve delivers 38 GPM (144 L/min) at 30 PSI (2.1 bar) pressure drop.

Hot Water Shutoff: Valve has internal PTFE valve seat. If the supply of cold water is interrupted, the valve will close completely and *not deliver any water at all*, eliminating any possibility of scalding.

Flow Capacity: Refer to table below for flow capacity of valve at specified pressure drops.

Checkstops/Filters: Each inlet has a lockable shutoff valve for maintenance, internal check valve to prevent backflow and stainless steel basket filter to remove debris from the water flow.

Construction: Valve meets the requirements of the U.S. Safe Drinking Water Act as lead-free.

Inlet/Outlet: 1" NPT female inlets and 1-1/4" NPT female outlet as standard.

Quality Assurance: Valve is ASSE certified under ANSI/ASSE 1071. Valve is fully assembled and factory tested prior to shipment.

Water Pressure/Temperature Requirements

Supply Pressure: Maximum incoming water pressure is 125 PSI (8.6 bar). Pressure of hot and cold water supplies can vary up to 25% and still deliver the flow and temperature required by ANSI/ASSE 1071.

Hot Water Supply Temperature: Incoming hot water temperature range is 120° - 180°F (49° - 82°C). Guardian recommends that the hot water temperature not exceed 140°F (60°C).

Cold Water Supply Temperature: Incoming cold water temperature range is 40° - 70°F (4° - 21°C). Cold water temperature must be at least 10°F (5.6°C) less than the temperature of the delivered tepid water.

Tepid Water Temperature: Temperature of tepid water is adjustable within a range of 65° - 95°F (18° - 35°C) and then locks in position. High temperature limit stop is set at 90°F (32°C) to prevent misadjustment.

G6040 Thermostatic Mixing Valve, 50 Gallon/189 Liter Capacity

Pressure Drop (PSI)	1	5	10	15	20	25	30	35	40
Flow Rate (GPM)	0.5	17	28	34	41	46	50	55	59
Bypass Flow Rate (GPM)	0.5	13	20	25	30	34	38	41	45

Pressure Drop (Bar)	0.1	0.3	0.7	1.0	1.4	1.7	2.1	2.4	2.8
Flow Rate (L/min)	2	64	106	129	155	174	189	208	223
Bypass Flow Rate (L/min)	2	49	76	95	114	129	144	155	170

Ordering Information

Models

<input type="checkbox"/>	G6040	Thermostatic Mixing Valve, 50 Gallon/189 Liter Capacity
<input type="checkbox"/>	G6041-XXX	G6040 valve installed in surface mounted powder coated steel cabinet
<input type="checkbox"/>	G6042-XXX	G6040 valve installed in surface mounted stainless steel cabinet
<input type="checkbox"/>	G6043-XXX	G6040 valve installed in recess mounted powder coated steel cabinet
<input type="checkbox"/>	G6044-XXX	G6040 valve installed in recess mounted stainless steel cabinet

Available Options

<input type="checkbox"/>	Finish	Chrome plated finish in place of raw brass (add suffix "CP")
<input type="checkbox"/>	Inlet/Outlet Threads	G1 female thread on inlets and G1-1/4 female thread on outlet (add suffix "G")
<input type="checkbox"/>	Temperature Gauges	Temperature gauges on hot and cold water inlets (add suffix "IT")
<input type="checkbox"/>	Pressure Gauges	Pressure gauges on hot and cold water inlets (add suffix "IP")
<input type="checkbox"/>	Temperature/Pressure Gauges	Temperature and pressure gauges on hot and cold water inlets (add suffix "ITP")

Note: Installation of temperature and/or pressure gauges will change rough-in dimensions of valve. Contact factory for catalog drawing.

G6040 Thermostatic Mixing Valve, 50 Gallon/189 Liter Capacity

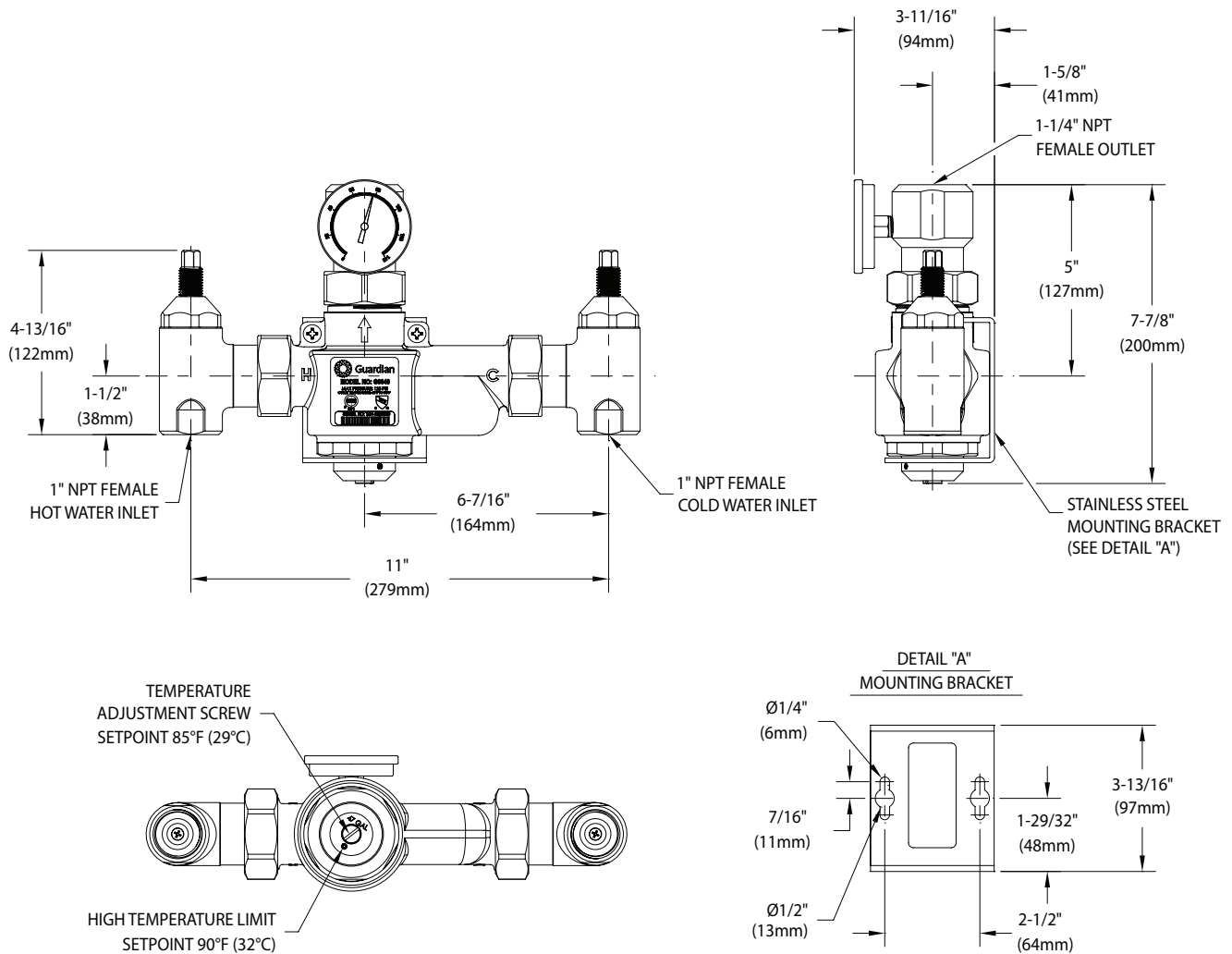

Notes:

1. ANSI Z358.1-2014 states that the water temperature delivered by emergency equipment should be “tepid”. Tepid is defined as 60°F - 100°F (16°C - 38°C). However, in circumstances where a chemical reaction can be accelerated by water temperature, a medical professional should be consulted to determine the optimum water temperature for the application.
2. For thermostatic mixing valves to deliver the required water temperature and volume, the system must be sized correctly. Please refer to the flow capacity, pressure and temperature requirements herein when designing the tepid water system.
3. Valve is factory set to deliver 85°F (29°C) tepid water. Depending on pressure and temperature of the incoming water supplies, this setting may require adjustment in the field. The adjustment screw is locked in position after adjusting.
4. Thermostatic mixing valves, like all emergency equipment, must be installed in accordance with the manufacturer’s instructions and maintained on a regular basis. Per ANSI Z358.1-2014, all emergency equipment should be activated weekly and inspected at least annually. Thermostatic mixing valves should be treated the same.
5. Per ANSI Z358.1-2014, plumbed emergency equipment must be connected to a potable water supply. This valve meets the requirements of the U.S. Safe Drinking Water Act as lead-free and is safe for use with potable water.
6. This valve is supplied with shutoff valves. Per ANSI Z358.1-2014, if shutoff valves are installed on the water supply to emergency equipment, the valves must be lockable to prevent unauthorized shutoff. Accordingly, each shutoff valve stem on this valve has a hole for installing a lock to secure the stem in the open position.

THIS SPACE FOR ARCHITECT/ENGINEER APPROVAL

Due to continuing product improvement, the information contained in this document is subject to change without notice. All dimensions are ± 1/4" (6mm). Rev. 022420



G6041-XXX G6040 Thermostatic Mixing Valve with Surface Mounted Powder Coated Steel Cabinet

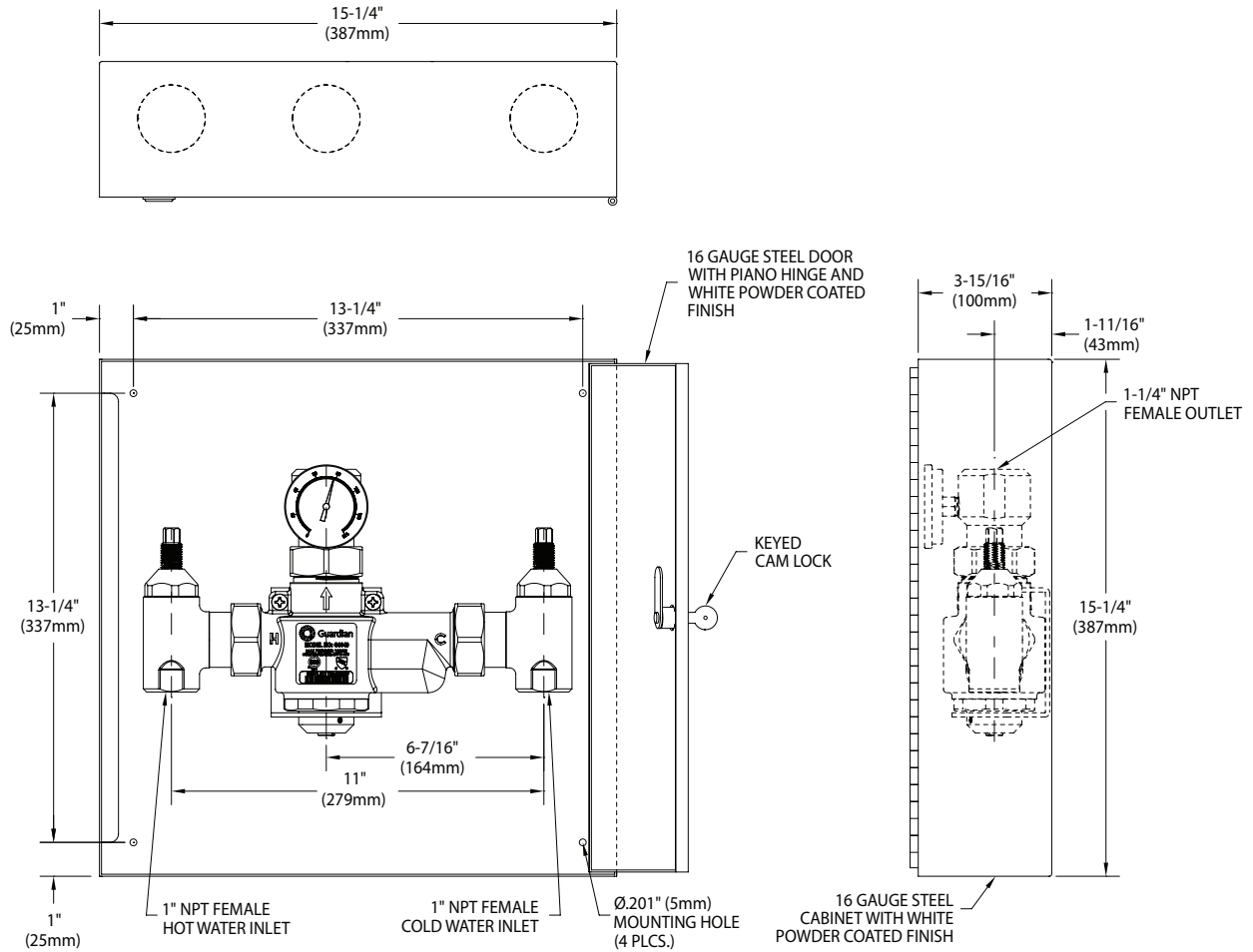

Ordering Information

When ordering the G6041-XXX, the three digit code added to the model number specifies the following information. If no code is specified, the unit will be supplied with code 1R1 (solid door, right hinge and bottom inlets/top outlet).

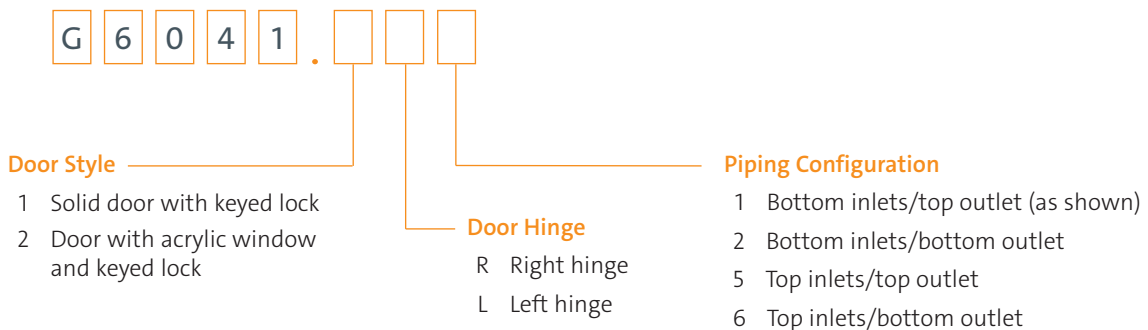

G6042-XXX G6040 Thermostatic Mixing Valve with Surface Mounted Stainless Steel Cabinet

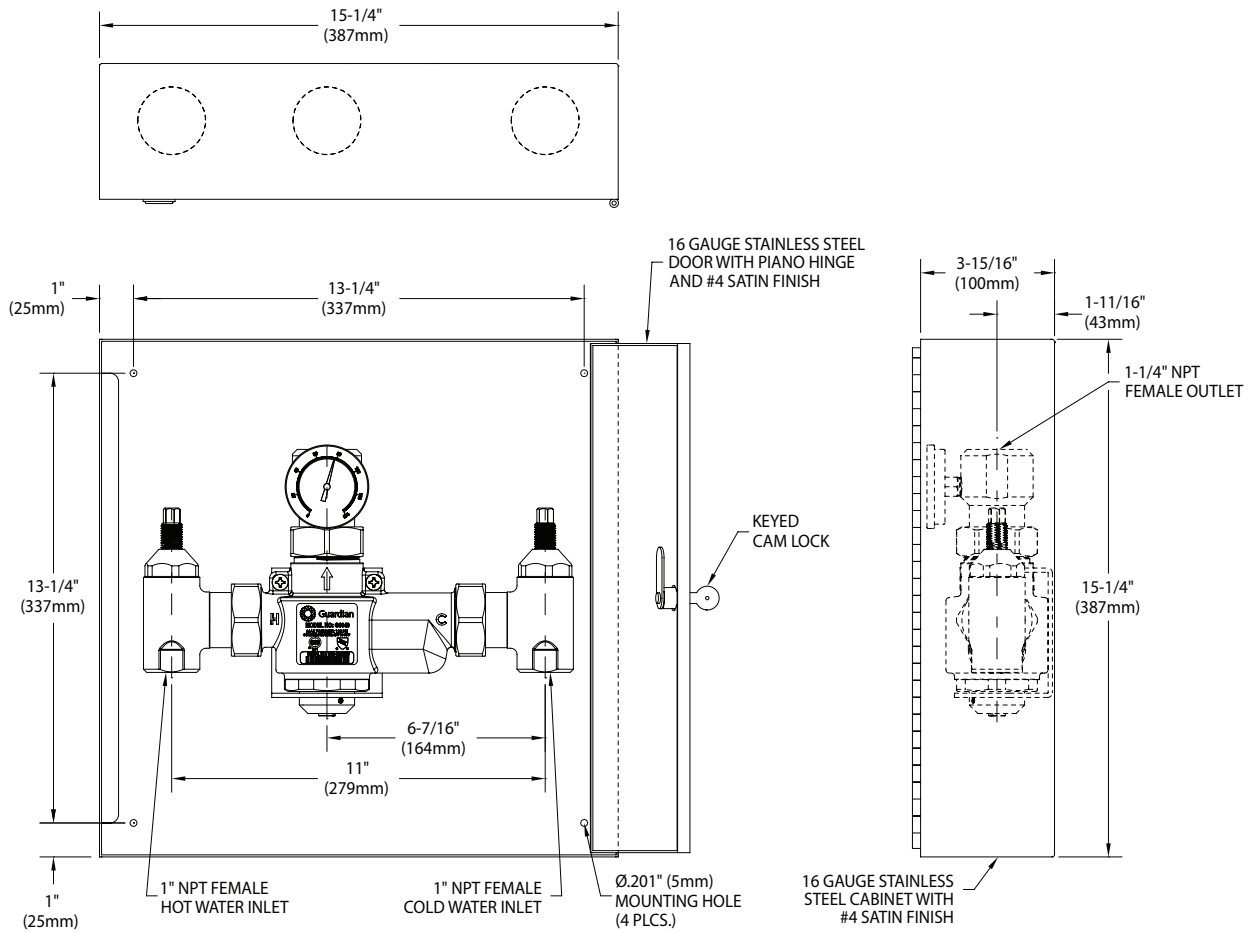

Ordering Information

When ordering the G6042-XXX, the three digit code added to the model number specifies the following information. If no code is specified, the unit will be supplied with code 1R1 (solid door, right hinge and bottom inlets/top outlet).

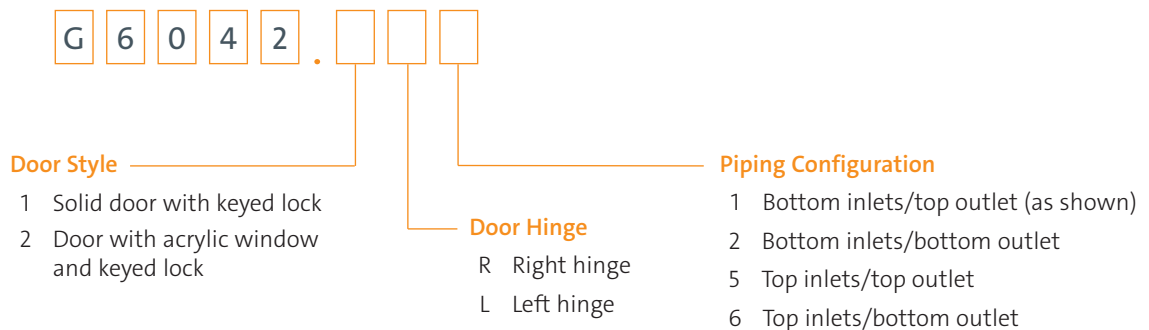

G6043-XXX G6040 Thermostatic Mixing Valve with Recess Mounted Powder Coated Steel Cabinet

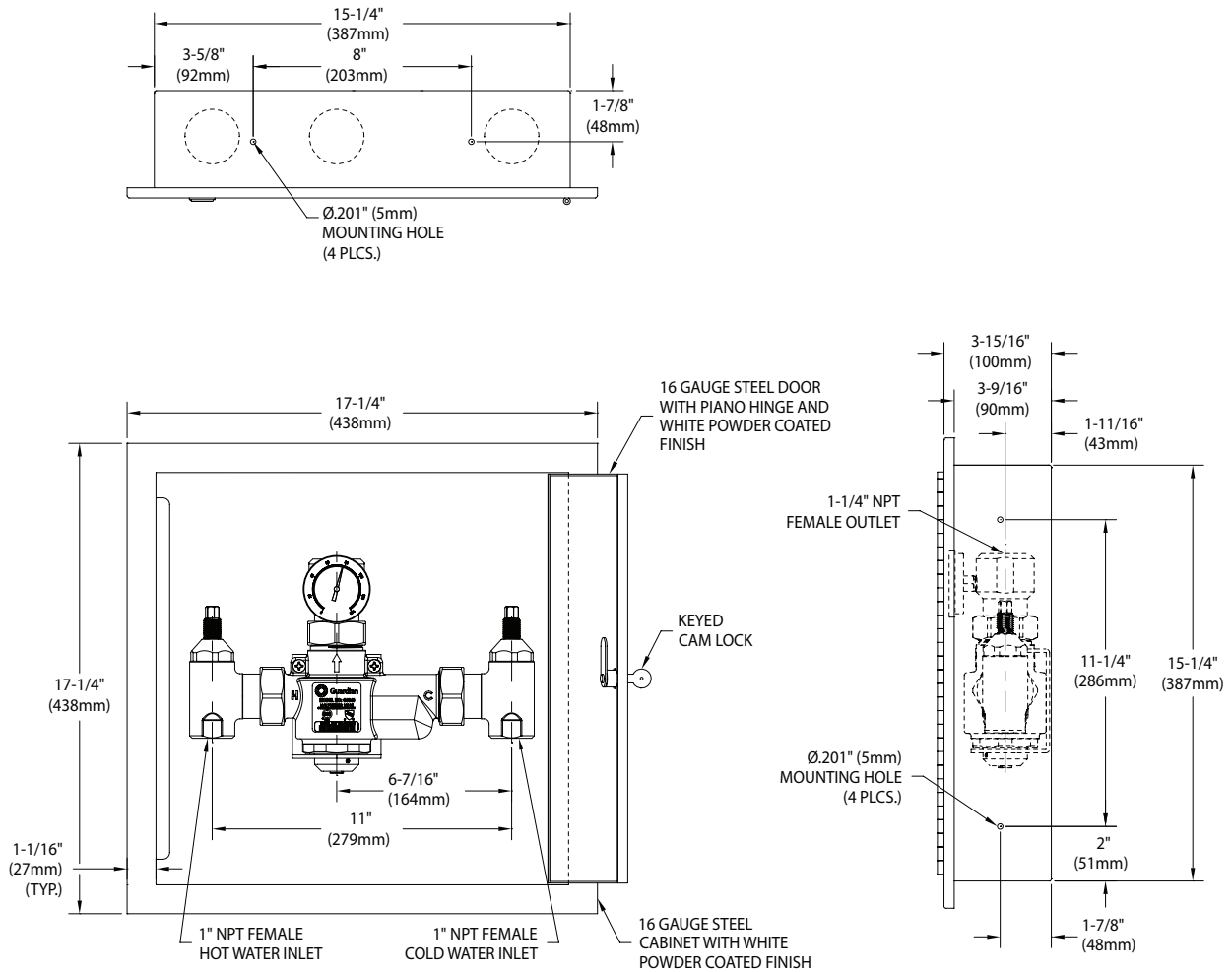

Ordering Information

When ordering the G6043-XXX, the three digit code added to the model number specifies the following information. If no code is specified, the unit will be supplied with code 1R1 (solid door, right hinge and bottom inlets/top outlet).

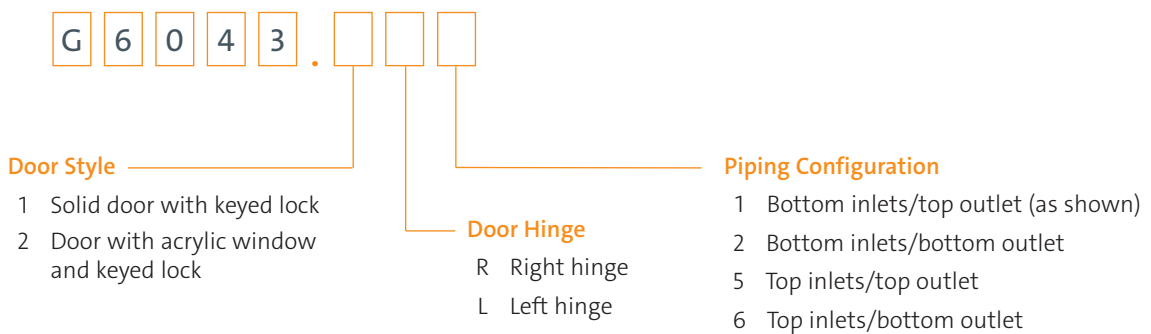

G6044-XXX G6040 Thermostatic Mixing Valve with Recess Mounted Stainless Steel Cabinet

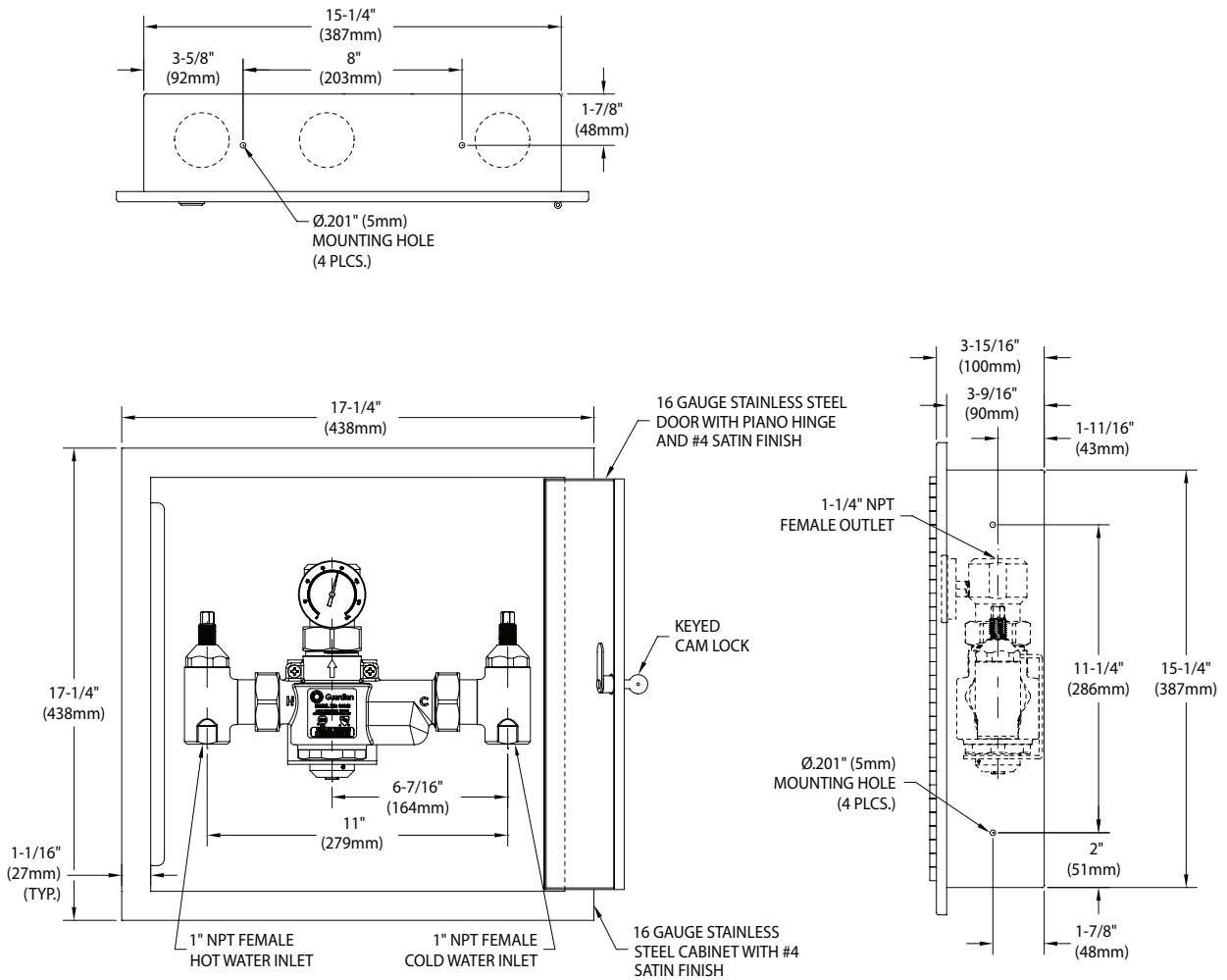

Ordering Information

When ordering the G6044-XXX, the three digit code added to the model number specifies the following information. If no code is specified, the unit will be supplied with code 1R1 (solid door, right hinge and bottom inlets/top outlet).

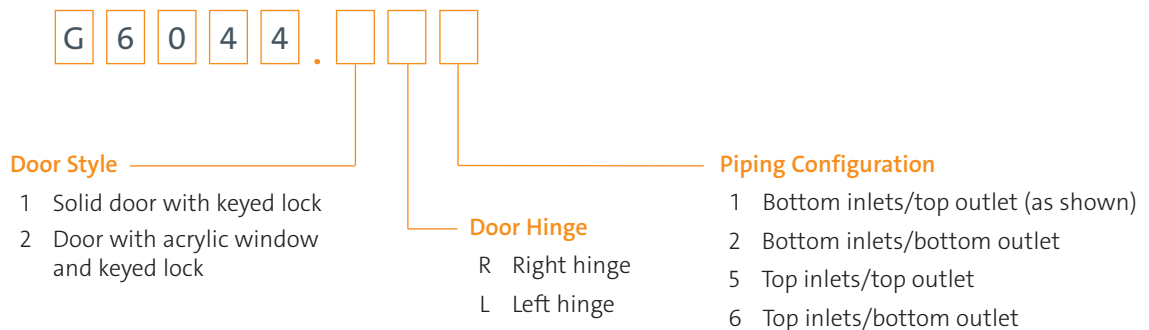

Global Distribution Centers

Guardian Equipment Inc. is a member of the WaterSaver group of companies. WaterSaver Faucet Co. is the largest worldwide manufacturer of faucets, valves and related products for use in science laboratories. WaterSaver and Guardian products are distributed globally from the following distribution centers:

Guardian Equipment Inc.
1140 N North Branch St.
Chicago, IL 60642
312 447 8100 TELEPHONE
312 447 8101 FACSIMILE

WaterSaver Faucet
de Mexico SA de CV
Calle Octava #1140
Parque Industrial Monterrey
Apodaca, NL 66603
52 81 1090 0000 TELEPHONE

WaterSaver LabTaps Ltd
Unit 11
High Carr Network Centre
Newcastle-Under-Lyme
Staffordshire, England, ST5 7XE
44 01782 576910 TELEPHONE
44 01782 576911 FACSIMILE



WaterSaver Sales Asia Pte Ltd
30 Petain Road
208099 Singapore
65 6883 2105 TELEPHONE
65 6883 2509 FACSIMILE

WaterSaver (Shanghai) Trading Co. Ltd.
Rm 205, Bldg No. 1
No. 456 Xiao Mu Qiao Rd, Xu Hui District
200032 Shanghai City, China
+86 21 3183 9266/8 TELEPHONE

Ila GmbH
Otto-Hahn Str 10
64579 Gernsheim Germany
49 6258 9495 0 TELEPHONE
49 6258 9495 10 FAX